

TB6615PG

STEPPING MOTOR CONTROLLER / DRIVER

The TB6615PG is a stepping motor controller/driver with MOS output transistors. The TB6615PG can drive a two-phase stepping motor in unipolar mode, and allow the selection of rotation direction between forward and reverse by using clock signals. It also supports several excitation modes (1-phase, 2-phase and 1-2-phase).

FEATURES

- Single-chip stepping motor controller/driver
- All inputs are TTL level.
- The CK1, CK2, CW/CCW and RESET pins are Schmitt trigger inputs.
- Rotation direction control (Clockwise (CW)/counterclockwise (CCW)): Single-clock and dual-clock modes
- Output enable and initial state detection capabilities
- High output withstand voltage: $V_{CE(SUS)}\phi = 28\text{ V (MIN)}$
- High output current: $I_{OUT\phi} = 400\text{ mA (MAX)}$
- Package: DIP-16
- The overvoltage protection circuitry is provided on each output. (It is activated when the output voltage reaches 30 V (typ.) or higher.)

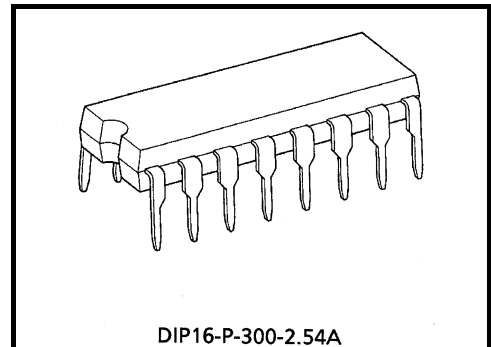

Weight : 1.11 g (typ.)

BLOCK DIAGRAM

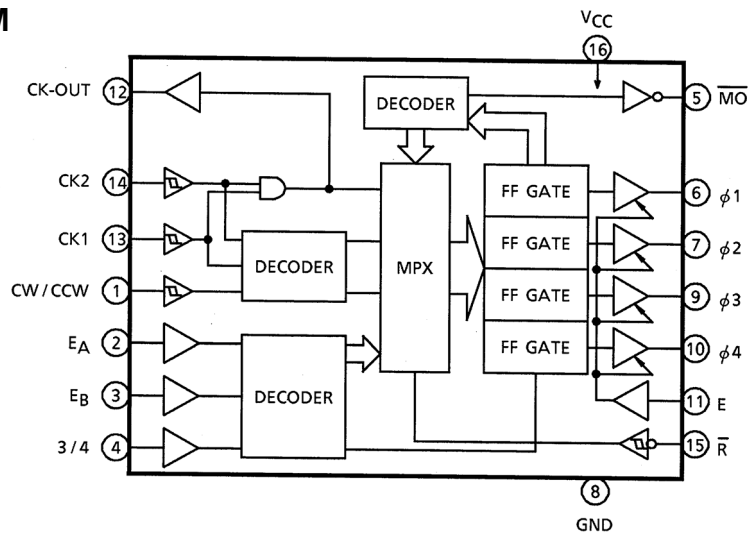

PIN DESCRIPTION

PIN No.	SYMBOL	PIN NAME	FUNCTIONAL DESCRIPTION
1	CW/CCW	Clockwise/Counterclockwise	Rotation Direction Select Input (See Truth Table A.)
2	E _A	Excitation A	Excitation Mode Select Input See Truth Table B.
3	E _B	Excitation B	
4	3/4	3 Phases/4 Phases	
5	\overline{MO}	Monitor Out	Initial State Detection Output; this pin is set Low in the initial state.
6	$\phi 1$	$\phi 1$ Out	$\phi 1$ Output
7	$\phi 2$	$\phi 2$ Out	$\phi 2$ Output
8	GND	GND	Ground
9	$\phi 3$	$\phi 3$ Out	$\phi 3$ Output
10	$\phi 4$	$\phi 4$ Out	$\phi 4$ Output
11	E	Output Enable	Outputs $\phi 1$ through $\phi 4$ are enabled when this pin is High.
12	CK-OUT	Clock-Out	Clock Output
13	CK1	Clock I _n -1	Clock Input 1
14	CK2	Clock I _n -2	Clock Input 2
15	\overline{R}	Reset	Reset Input; outputs are reset when this pin is Low (Note 1)
16	V _{CC}	V _{CC}	V _{CC}

TRUTH TABLE A

CK1	CK2	CW/CCW	FUNCTION
	H	L	CW
	L	L	Inhibit (Note 2)
H		L	CCW
L		L	Inhibit (Note 2)
	H	H	CCW
	L	H	Inhibit (Note 2)
H		H	CW
L		H	Inhibit (Note 2)

TRUTH TABLE B

E _A	E _B	3/4 (Note 3)	FUNCTION	
L	L	L	4-Phase Output	1-Phase Excitation
H	L	L		2-Phase Excitation
L	H	L		1-2-Phase Excitation
H	H	L	Test Mode: All outputs are enabled	
L	L	H	3-Phase Output	1-Phase Excitation
H	L	H		2-Phase Excitation
L	H	H		1-2-Phase Excitation
H	H	H	Test Mode: All outputs are enabled.	

Note 1: Setting the Reset pin Low causes the output state to enter the initial state, and the \overline{MO} output to become Low.

Once the Reset pin is set High, the output state enters the state following the initial state at the next rising edge of the clock signal.

Note 2: Do not use Inhibit mode.

Note 3: Before switching the 3/4, E_A and/or E_B pins, put the TB6615PG into Reset mode by applying the Reset pulse.

Note 4: A two-phase stepping motor should be driven in four-phase output modes.

EQUIVALENT CIRCUITS

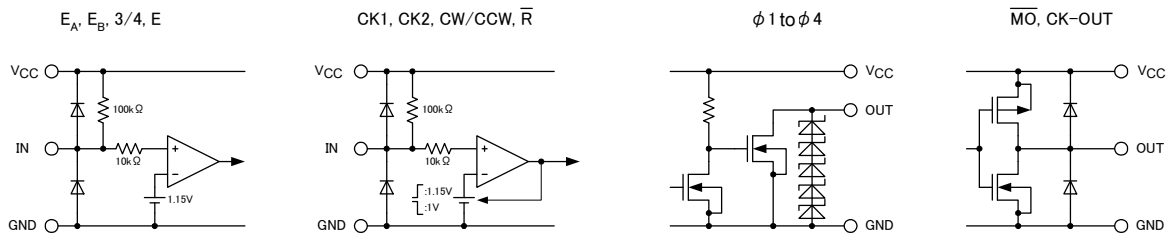

ABSOLUTE MAXIMUM RATINGS (Ta = 25°C)

CHARACTERISTICS	SYMBOL	RATING	UNIT
Supply Voltage	V_{CC}	-0.3 to 6.0	V
Output Withstanding Voltage (ϕ n)	$V_{CE(SUS)\phi}$	-0.3 to 28	V
Output Current (ϕ n)	$I_{OUT\phi}$	400	mA
Output Current (MO, CK-OUT)	$I_{OUT\overline{MO}}$ I_{CK-OUT}	10	mA
Input Voltage	V_{IN}	-0.3 to $V_{CC} + 0.3$	V
Input Current	I_{IN}	± 1	mA
Power Dissipation	P_D	1.8	W
Operating Temperature	T_{opr}	-30 to 85	°C
Storage Temperature	T_{stg}	-55 to 150	°C

OPERATION RANGE (Ta = 25°C)

CHARACTERISTICS	SYMBOL	TEST CONDITIONS	MIN	TYP.	MAX	UNIT
Supply Voltage	V_{CC}	—	2.7	5.0	5.5	V
Output Withstanding Voltage	$V_{CE(SUS)\phi}$	—	0	—	26	V
Output Current ϕ n	Low	$I_{OUT\phi}$	—	—	200	mA
Output Current MO, CK-OUT	High	I_{OH}	—	—	-0.4	mA
	Low	I_{OL}	—	—	8	
Input Voltage	V_{IN}	—	0	—	V_{CC}	V
Clock Frequency	f_{CLOCK}	—	0	—	100	kHz

ELECTRICAL CHARACTERISTICS (Ta = 25°C)

CHARACTERISTICS		SYMBOL	TEST CIR-CUIT	TEST CONDITIONS	MIN	TYP.	MAX	UNIT	
Input Voltage	High	V _{IH}	—	—	2.0	—	—	V	
	Low	V _{IL}	—	—	—	—	0.8		
Input Current	High	I _{IH}	—	V _{CC} = 5.5 V, V _{IH} = 5.5 V	—	—	2	μA	
	Low	I _{IL}	—	V _{CC} = 5.5 V, V _{IL} = 0.4 V	—	—	-0.15	mA	
Hysteresis Voltage		ΔV _T	—	V _{CC} = 5.0 V	—	150	—	mV	
Current Consumption		I _{CC}	—	V _{CC} = 5.5 V	—	—	27	mA	
Output Leakage Current φ _n		I _{OHφ}	—	V _{CC} = 5.5 V, V _{OUT} = 26 V	—	—	1	μA	
Output Voltage	High	\overline{MO} CK-OUT	V _{OH}	—	V _{CC} = 2.7 V, I _{OH} = -0.4 mA	V _{CC} × 0.8	—	V	
	Low	\overline{MO} CK-OUT	V _{OL}	—	V _{CC} = 2.7 V, I _{OL} = 8 mA	—	—		V _{CC} × 0.2
		φ _n	V _{OUTφ}	—	V _{CC} = 2.7 V, I _{OUT} = 400 mA t = 100 ms	—	—		0.8
				—	V _{CC} = 2.7 V, I _{OUT} = 200 mA t = 100 ms	—	—		0.5

SWITCHING CHARACTERISTICS (Ta = 25°C)

CHARACTERISTICS		SYMBOL	TEST CIRCUIT	TEST CONDITIONS	MIN	TYP.	MAX	UNIT	
Propagation Delay	High	CK-φ _n	t _{pLH}	—	Design target only	—	200	—	ns
		CK-CK-OUT				—	100	—	
		CK- \overline{MO}				—	150	—	
		E-φ _n				—	200	—	
		\overline{R} -φ _n				—	200	—	
	Low	CK-φ _n	t _{pHL}	—	Design target only	—	200	—	
		CK-CK-OUT				—	110	—	
		CK- \overline{MO}				—	150	—	
		E-φ _n				—	200	—	
		\overline{R} -φ _n				—	200	—	
\overline{R} - \overline{MO}	—	110	—						
Maximum Operating Frequency		f _{max}	—	Design target only	—	250	—	kHz	
Setup Time (CK, CW/CCW)		t _{set-up}	—	Design target only	—	10	—	ns	
Hold Time (CK, CW/CCW)		t _{hold}							
Minimum Clock Pulse Width		t _w (CK)	—	Design target only	—	100	—		
Minimum Reset Pulse Width		t _w (\overline{R})	—	Design target only	—	100	—		
Maximum Clock Rise Time		t _r (CK)	—	Design target only	—	2	—		μs

TIMING CHARTS

THREE-PHASE OUTPUT MODES

1-PHASE EXCITATION (CW)

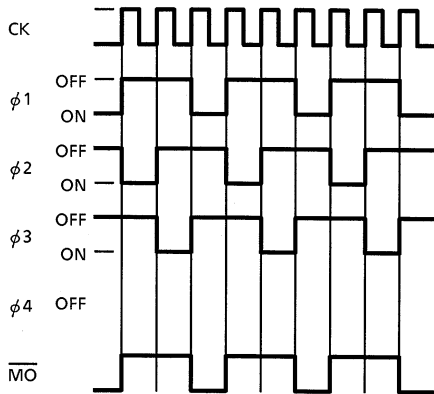

1-PHASE EXCITATION (CCW)

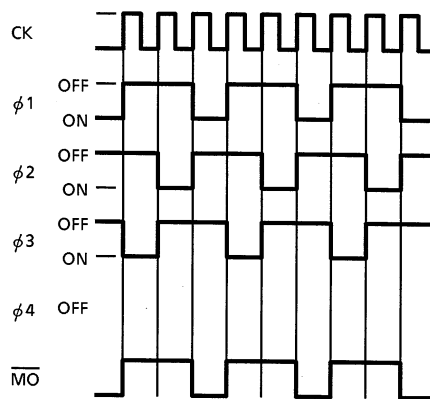

2-PHASE EXCITATION (CW)

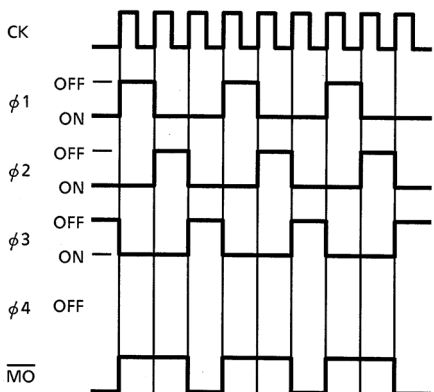

2-PHASE EXCITATION (CCW)

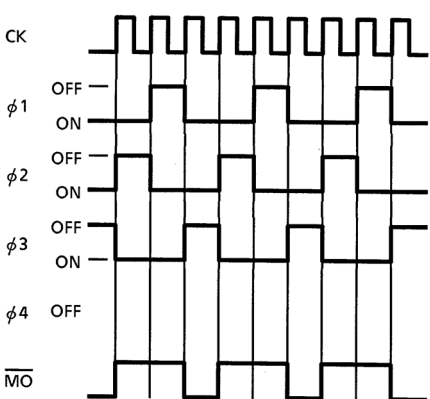

1-2-PHASE EXCITATION (CW)

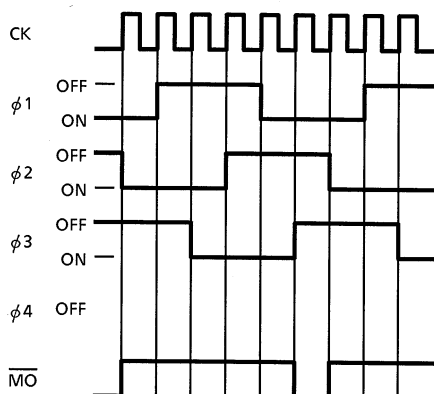

1-2-PHASE EXCITATION (CCW)

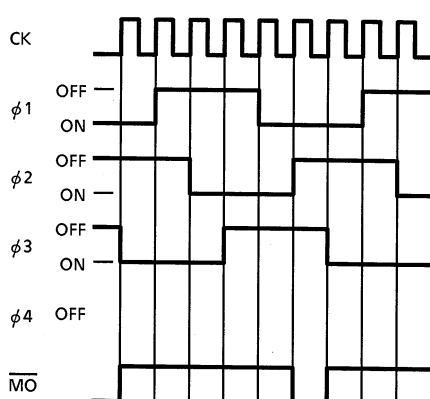

FOUR-PHASE OUTPUT MODES

1-PHASE EXCITATION (CW)

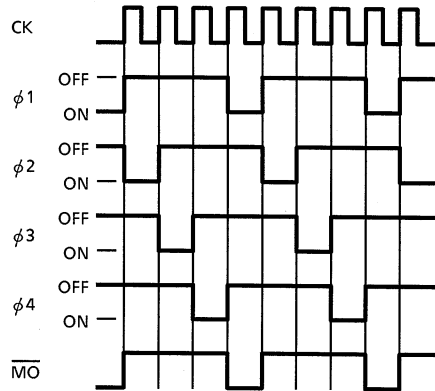

1-PHASE EXCITATION (CCW)

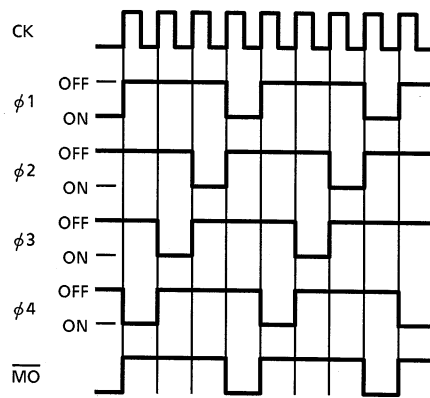

2-PHASE EXCITATION (CW)

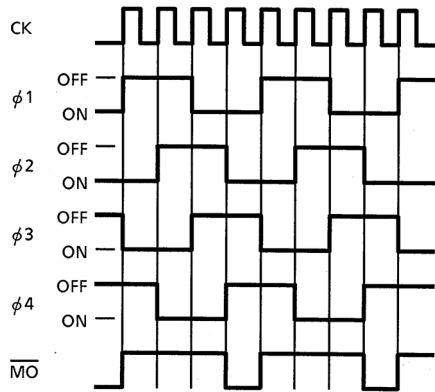

2-PHASE EXCITATION (CCW)

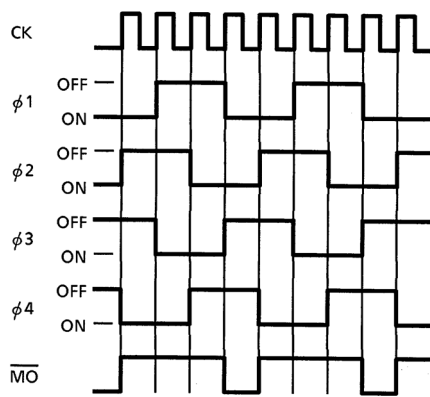

1-2-PHASE EXCITATION (CW)

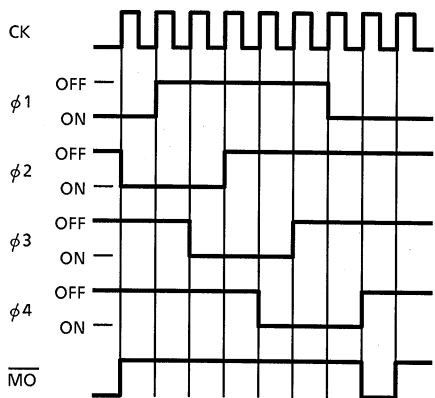

1-2-PHASE EXCITATION (CCW)

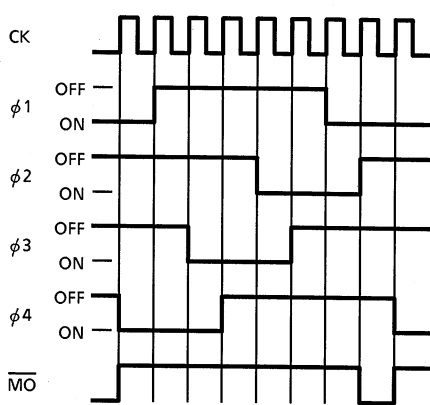

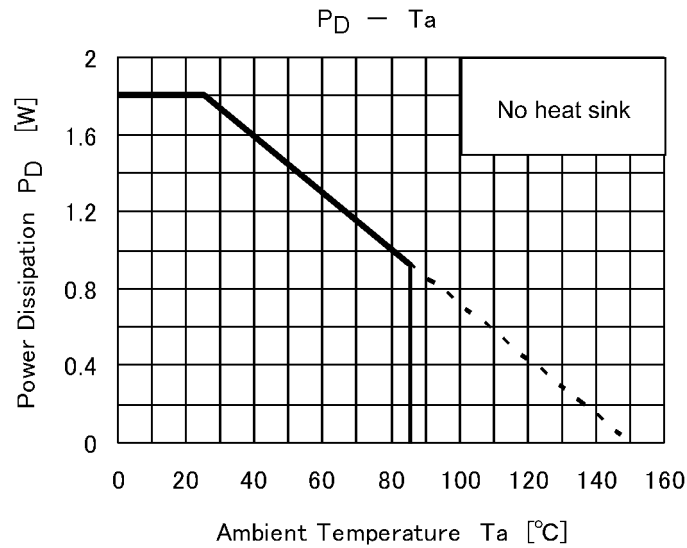

Usage Considerations

- The IC may be destroyed in case of a short-circuit across outputs, a short-circuit to power supply or a short-circuit to ground. This possibility should be fully considered in the design of the output, V_{CC} and ground lines.
- It should be ensured that the device is inserted properly. The IC may be damaged if it is inserted in the wrong orientation.
- If the device is damaged, a large current may continue to flow through the motor driver stage as a secondary effect. Therefore, Toshiba recommends that a fuse be connected to the power supply line at the driver stage.

Application Circuit Example 1

TB6615PG+TD62308BP-1

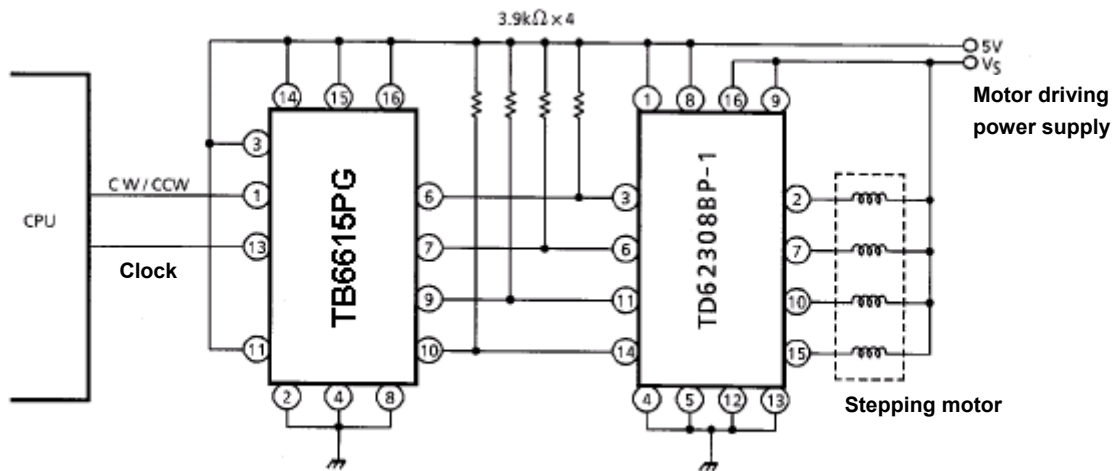

Application Circuit Example 2

TB6615G+TD62553S+MP4001

This circuit operates with two power supplies.

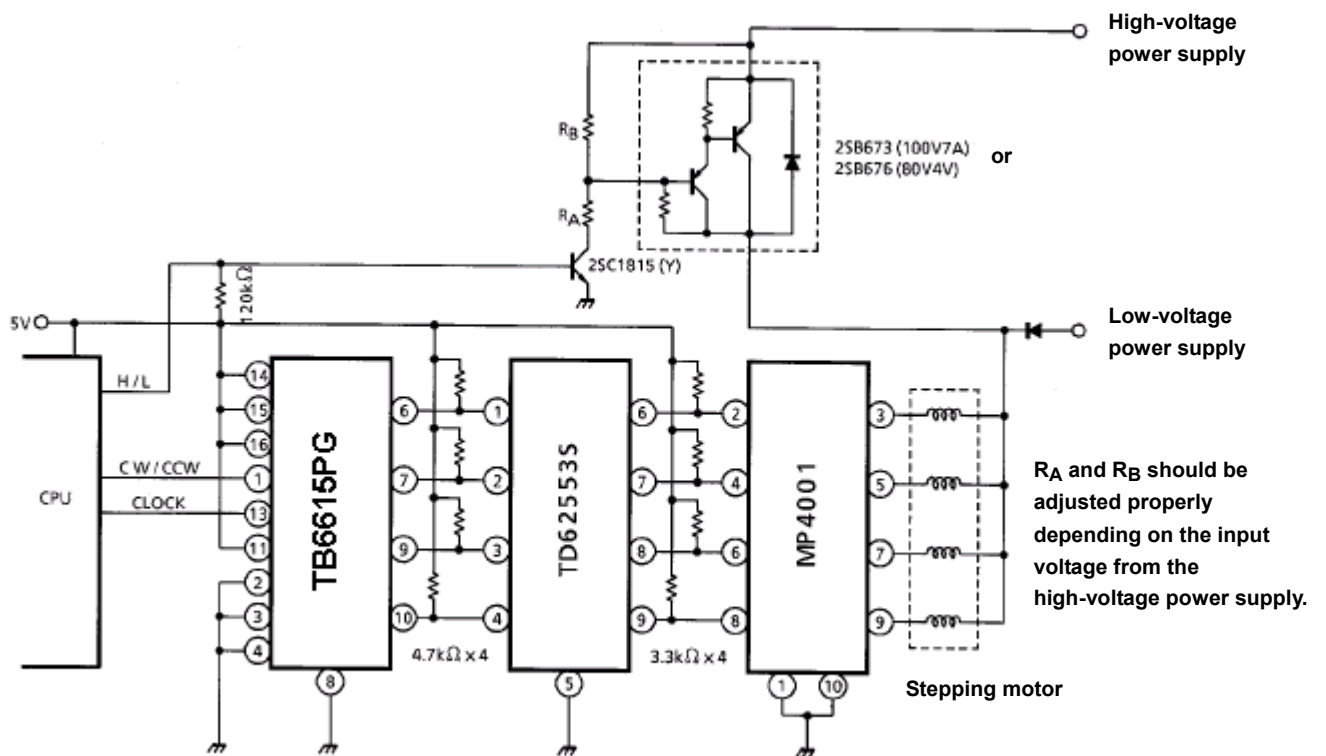

Application Circuit Example 3

1-2-phase excitation system for a two-phase motor, I

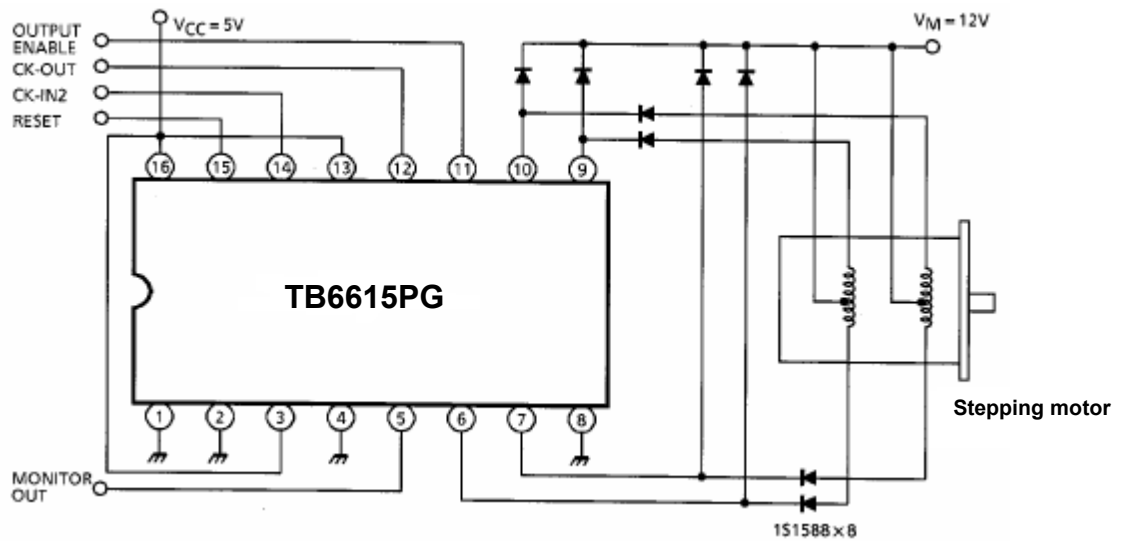

• When an inductive kick of the motor is large, the snubber diodes should be placed across the coil to suppress the inductive kick. (This also applies to Application Circuit Example 4.)

Application Circuit Example 4

1-2-phase excitation system for a two-phase motor, II

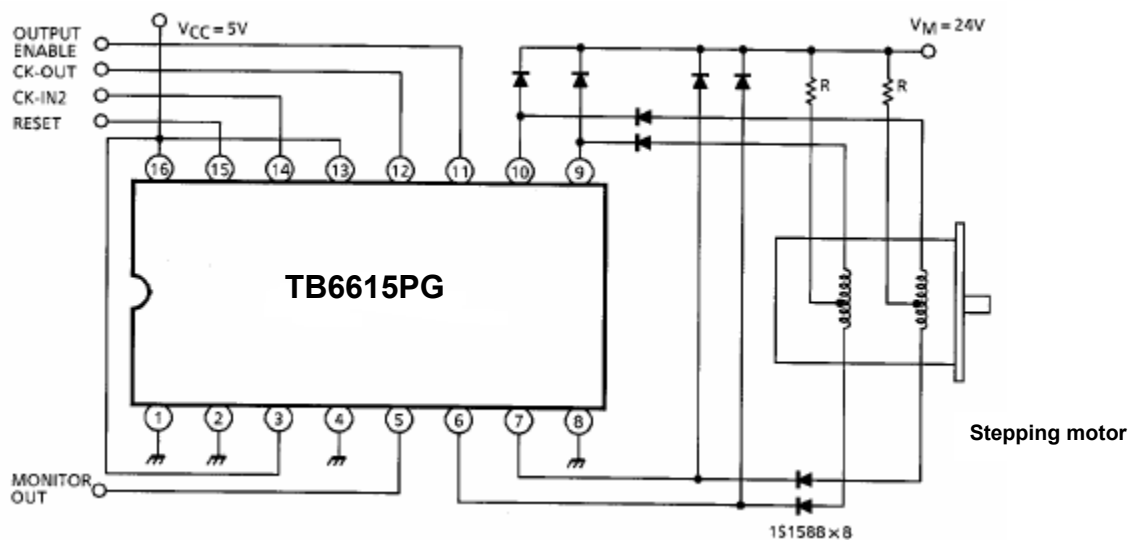

Note: The IC may be destroyed in case of a short-circuit across outputs, a short-circuit to power supply or a short-circuit to ground. This possibility should be fully considered in the design of the output, V_{CC} (V_M, V_S and V_{EE}) and ground lines.

PACKAGE DIMENSIONS

DIP16-P-300-2.54A

Unit: mm

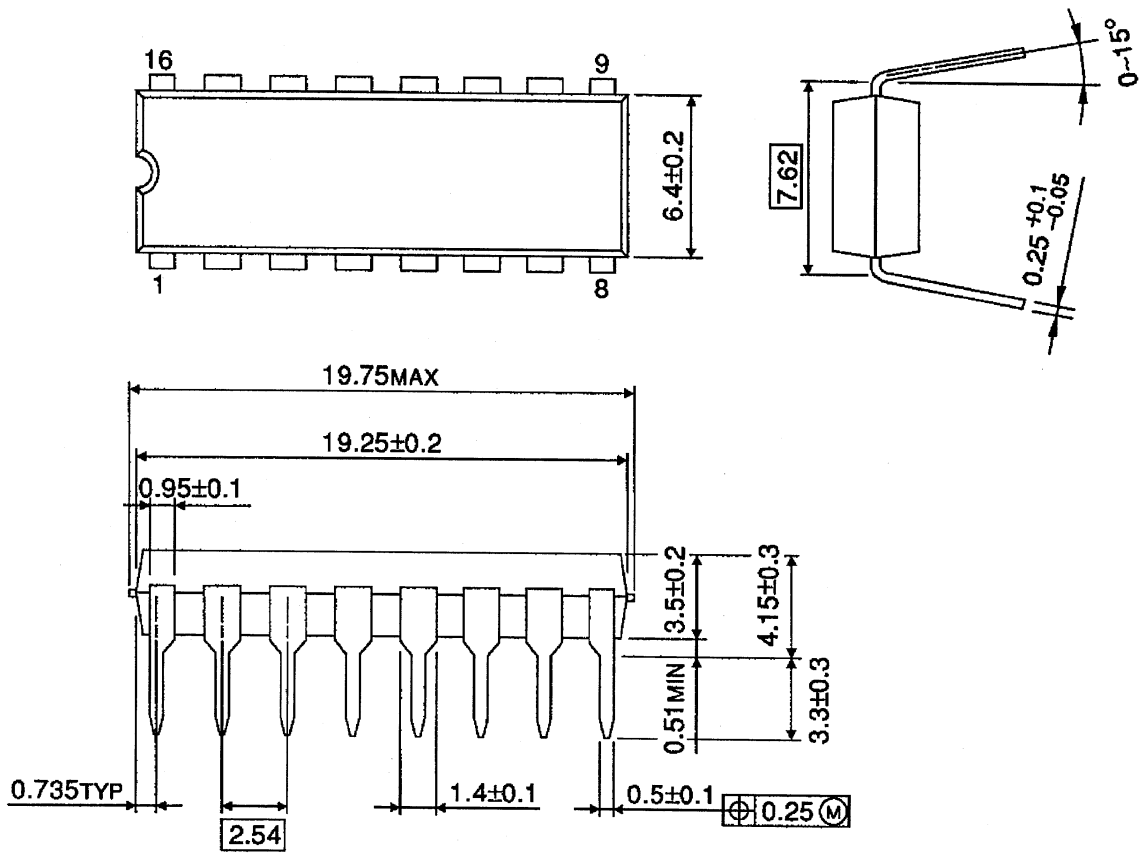

Weight: 1.11g (typ.)

Notes on Contents

1. Block Diagrams

Some of the functional blocks, circuits, or constants in the block diagram may be omitted or simplified for explanatory purposes.

2. Equivalent Circuits

The equivalent circuit diagrams may be simplified or some parts of them may be omitted for explanatory purposes.

3. Timing Charts

Timing charts may be simplified for explanatory purposes.

4. Application Circuits

The application circuits shown in this document are provided for reference purposes only. Thorough evaluation is required, especially at the mass production design stage.

Toshiba does not grant any license to any industrial property rights by providing these examples of application circuits.

5. Test Circuits

Components in the test circuits are used only to obtain and confirm the device characteristics. These components and circuits are not guaranteed to prevent malfunction or failure from occurring in the application equipment.

IC Usage Considerations

Notes on handling of ICs

- [1] The absolute maximum ratings of a semiconductor device are a set of ratings that must not be exceeded, even for a moment. Do not exceed any of these ratings.
Exceeding the rating(s) may cause the device breakdown, damage or deterioration, and may result injury by explosion or combustion.
- [2] Use an appropriate power supply fuse to ensure that a large current does not continuously flow in case of over current and/or IC failure. The IC will fully break down when used under conditions that exceed its absolute maximum ratings, when the wiring is routed improperly or when an abnormal pulse noise occurs from the wiring or load, causing a large current to continuously flow and the breakdown can lead smoke or ignition. To minimize the effects of the flow of a large current in case of breakdown, appropriate settings, such as fuse capacity, fusing time and insertion circuit location, are required.
- [3] If your design includes an inductive load such as a motor coil, incorporate a protection circuit into the design to prevent device malfunction or breakdown caused by the current resulting from the inrush current at power ON or the negative current resulting from the back electromotive force at power OFF. IC breakdown may cause injury, smoke or ignition.
Use a stable power supply with ICs with built-in protection functions. If the power supply is unstable, the protection function may not operate, causing IC breakdown. IC breakdown may cause injury, smoke or ignition.
- [4] Do not insert devices in the wrong orientation or incorrectly.
Make sure that the positive and negative terminals of power supplies are connected properly.
Otherwise, the current or power consumption may exceed the absolute maximum rating, and exceeding the rating(s) may cause the device breakdown, damage or deterioration, and may result injury by explosion or combustion.
In addition, do not use any device that is applied the current with inserting in the wrong orientation or incorrectly even just one time.

Points to remember on handling of ICs**(1) Overcurrent Protection Circuit**

Overcurrent protection circuits (referred to as current limiter circuits) do not necessarily protect ICs under all circumstances. If the Over current protection circuits operate against the over current, clear the over current status immediately.

Depending on the method of use and usage conditions, such as exceeding absolute maximum ratings can cause the over current protection circuit to not operate properly or IC breakdown before operation. In addition, depending on the method of use and usage conditions, if over current continues to flow for a long time after operation, the IC may generate heat resulting in breakdown.

(2) Heat Radiation Design

In using an IC with large current flow such as power amp, regulator or driver, please design the device so that heat is appropriately radiated, not to exceed the specified junction temperature (T_j) at any time and condition. These ICs generate heat even during normal use. An inadequate IC heat radiation design can lead to decrease in IC life, deterioration of IC characteristics or IC breakdown. In addition, please design the device taking into consideration the effect of IC heat radiation with peripheral components.

(3) Back-EMF

When a motor rotates in the reverse direction, stops or slows down abruptly, a current flow back to the motor's power supply due to the effect of back-EMF. If the current sink capability of the power supply is small, the device's motor power supply and output pins might be exposed to conditions beyond absolute maximum ratings. To avoid this problem, take the effect of back-EMF into consideration in system design.

RESTRICTIONS ON PRODUCT USE

- Toshiba Corporation, and its subsidiaries and affiliates (collectively "TOSHIBA"), reserve the right to make changes to the information in this document, and related hardware, software and systems (collectively "Product") without notice.
- This document and any information herein may not be reproduced without prior written permission from TOSHIBA. Even with TOSHIBA's written permission, reproduction is permissible only if reproduction is without alteration/omission.
- Though TOSHIBA works continually to improve Product's quality and reliability, Product can malfunction or fail. Customers are responsible for complying with safety standards and for providing adequate designs and safeguards for their hardware, software and systems which minimize risk and avoid situations in which a malfunction or failure of Product could cause loss of human life, bodily injury or damage to property, including data loss or corruption. Before customers use the Product, create designs including the Product, or incorporate the Product into their own applications, customers must also refer to and comply with (a) the latest versions of all relevant TOSHIBA information, including without limitation, this document, the specifications, the data sheets and application notes for Product and the precautions and conditions set forth in the "TOSHIBA Semiconductor Reliability Handbook" and (b) the instructions for the application with which the Product will be used with or for. Customers are solely responsible for all aspects of their own product design or applications, including but not limited to (a) determining the appropriateness of the use of this Product in such design or applications; (b) evaluating and determining the applicability of any information contained in this document, or in charts, diagrams, programs, algorithms, sample application circuits, or any other referenced documents; and (c) validating all operating parameters for such designs and applications. **TOSHIBA ASSUMES NO LIABILITY FOR CUSTOMERS' PRODUCT DESIGN OR APPLICATIONS.**
- **PRODUCT IS NEITHER INTENDED NOR WARRANTED FOR USE IN EQUIPMENTS OR SYSTEMS THAT REQUIRE EXTRAORDINARILY HIGH LEVELS OF QUALITY AND/OR RELIABILITY, AND/OR A MALFUNCTION OR FAILURE OF WHICH MAY CAUSE LOSS OF HUMAN LIFE, BODILY INJURY, SERIOUS PROPERTY DAMAGE AND/OR SERIOUS PUBLIC IMPACT ("UNINTENDED USE").** Except for specific applications as expressly stated in this document, Unintended Use includes, without limitation, equipment used in nuclear facilities, equipment used in the aerospace industry, Class 3 medical devices, equipment used for automobiles, and military vehicles and munitions. **IF YOU USE PRODUCT FOR UNINTENDED USE, TOSHIBA ASSUMES NO LIABILITY FOR PRODUCT.** For details, please contact your TOSHIBA sales representative or contact us via our website.
- Do not disassemble, analyze, reverse-engineer, alter, modify, translate or copy Product, whether in whole or in part.
- Product shall not be used for or incorporated into any products or systems whose manufacture, use, or sale is prohibited under any applicable laws or regulations.
- The information contained herein is presented only as guidance for Product use. No responsibility is assumed by TOSHIBA for any infringement of patents or any other intellectual property rights of third parties that may result from the use of Product. No license to any intellectual property right is granted by this document, whether express or implied, by estoppel or otherwise.
- **ABSENT A WRITTEN SIGNED AGREEMENT, EXCEPT AS PROVIDED IN THE RELEVANT TERMS AND CONDITIONS OF SALE FOR PRODUCT, AND TO THE MAXIMUM EXTENT ALLOWABLE BY LAW, TOSHIBA (1) ASSUMES NO LIABILITY WHATSOEVER, INCLUDING WITHOUT LIMITATION, INDIRECT, CONSEQUENTIAL, SPECIAL, OR INCIDENTAL DAMAGES OR LOSS, INCLUDING WITHOUT LIMITATION, LOSS OF PROFITS, LOSS OF OPPORTUNITIES, BUSINESS INTERRUPTION AND LOSS OF DATA, AND (2) DISCLAIMS ANY AND ALL EXPRESS OR IMPLIED WARRANTIES AND CONDITIONS RELATED TO SALE, USE OF PRODUCT, OR INFORMATION, INCLUDING WARRANTIES OR CONDITIONS OF MERCHANTABILITY, FITNESS FOR A PARTICULAR PURPOSE, ACCURACY OF INFORMATION, OR NONINFRINGEMENT.**
- Do not use or otherwise make available Product or related software or technology for any military purposes, including without limitation, for the design, development, use, stockpiling or manufacturing of nuclear, chemical, or biological weapons or missile technology products (mass destruction weapons). Product and related software and technology may be controlled under the applicable export laws and regulations including, without limitation, the Japanese Foreign Exchange and Foreign Trade Law and the U.S. Export Administration Regulations. Export and re-export of Product or related software or technology are strictly prohibited except in compliance with all applicable export laws and regulations.
- Please contact your TOSHIBA sales representative for details as to environmental matters such as the RoHS compatibility of Product. Please use Product in compliance with all applicable laws and regulations that regulate the inclusion or use of controlled substances, including without limitation, the EU RoHS Directive. **TOSHIBA ASSUMES NO LIABILITY FOR DAMAGES OR LOSSES OCCURRING AS A RESULT OF NONCOMPLIANCE WITH APPLICABLE LAWS AND REGULATIONS.**