

TC78H660FNG

Dual H Bridge driver IC

1. Outline

The TC78H660FNG is a dual H Bridge driver IC which incorporates DMOS with low on-resistance in output transistors.

It can control two DC brushed motors or one stepping motor.

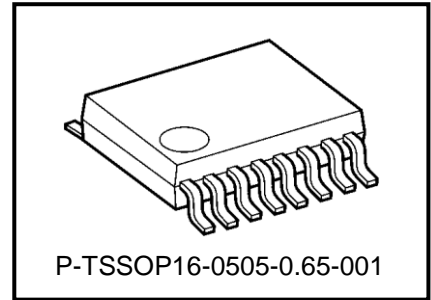

Weight: 56.5 mg (typ.)

2. Features

- Built-in Dual H Bridge
- PWM controlled constant-current drive
- Power supply operating voltage: 2.5 V to 16.0 V
- Output current ratings: 2.0 A (max)
- Low on-resistance (High + Low side = 0.48 Ω (typ.)) MOSFET output stage
- Built-in Sense resistor less current control architecture (Advanced Current Detection System)
- Multi error detect functions (Thermal shutdown (TSD), Over current (ISD)) and Under voltage lockout(UVLO))
- Error detection (TSD/ISD) flag output function
- Built-in VCC regulator for internal circuit
- Chopping frequency of a motor can be adjusted by external resistor
- Selectable Forward / Reverse / Stop / Brake modes

Note: Please be careful about thermal conditions during using.

Start of commercial production
2020-09

3. Pin Assignment

(Top View)

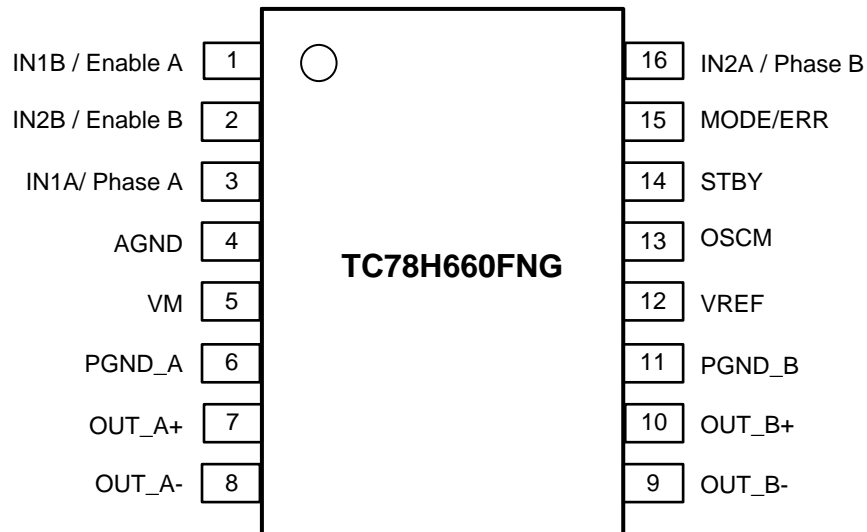

4. Pin Description

Pin No.	MODE = Low	MODE = High	Pin description
1	IN1B	Enable A	IN1B: B channel IN1 input pin Enable A: A channel Enable input pin
2	IN2B	Enable B	IN2B: B channel IN2 input pin Enable B: B channel Enable input pin
3	IN1A	Phase A	IN1A: A channel IN1 input pin Phase A: A channel Phase input pin
4	AGND	<-	Ground pin
5	VM	<-	Motor power supply input pin
6	PGND_A	<-	A channel Power ground pin
7	OUT_A+	<-	A channel motor output(+) pin
8	OUT_A-	<-	A channel motor output(-) pin
9	OUT_B-	<-	B channel motor output(-) pin
10	OUT_B+	<-	B channel motor output(+) pin
11	PGND_B	<-	B channel Power ground
12	VREF	<-	Current threshold reference pin
13	OSCM	<-	Internal oscillator frequency setting pin
14	STBY	<-	Standby pin
15	MODE / ERR	<-	Control mode select pin / Error detection flag output pin
16	IN2A	Phase B	IN2A: A channel IN2 input pin Phase B: B channel Phase input pin

5. Block Diagram

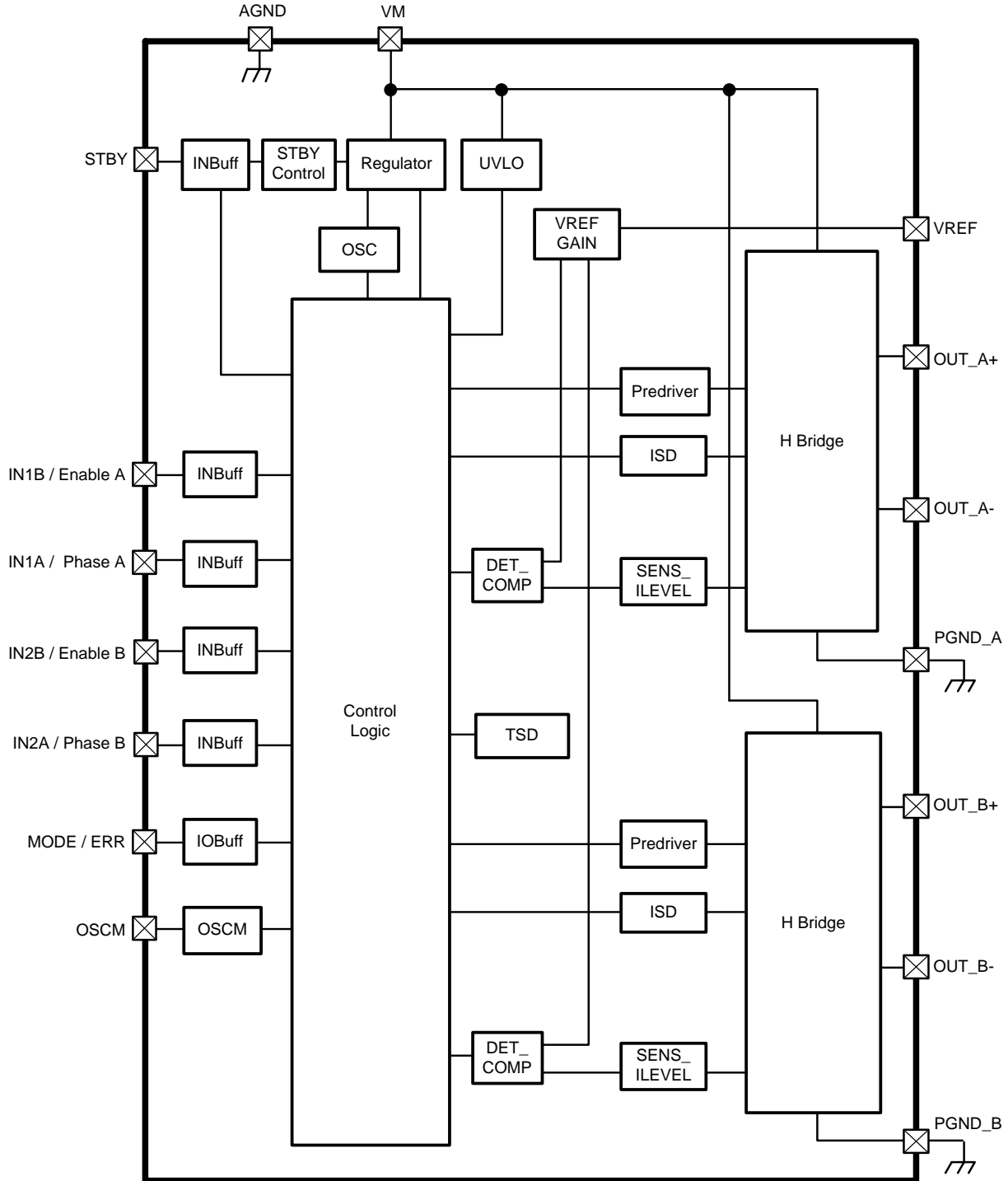

Note: Some of the functional blocks, circuits, or constants in the block diagram may be omitted or simplified for explanatory purpose.

Note: All the grounding wires should be solid patterns and be externally terminated at only one point. Also, a grounding method should be considered for efficient heat dissipation. Careful attention should be paid to the layout of the output, VM and GND traces, to avoid short circuits across output pins or to the power supply or ground. If such a short circuit occurs, the device may be permanently damaged. Also, the utmost care should be taken for pattern designing and implementation of the device since it has power supply pins (VM, AGND, PGND_x, OUT_x+, and OUT_x- (x = A or B)) through which a particularly large current may run. If these pins are wired incorrectly, an operation error may occur or the device may be destroyed. The logic input pins must also be wired correctly. Otherwise, the device may be damaged owing to a current running through the IC that is larger than the specified current. Careful attention should be paid to design patterns and mounting.

6. Input / Output Equivalent Circuit

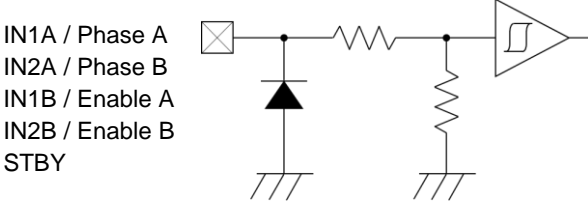
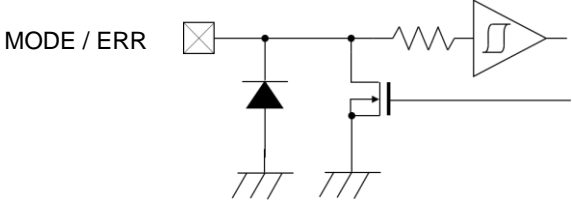
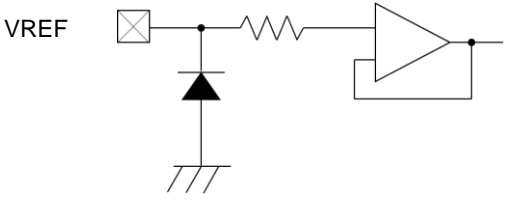
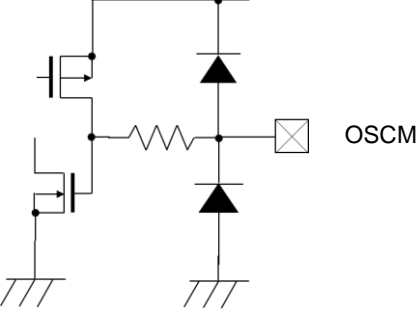
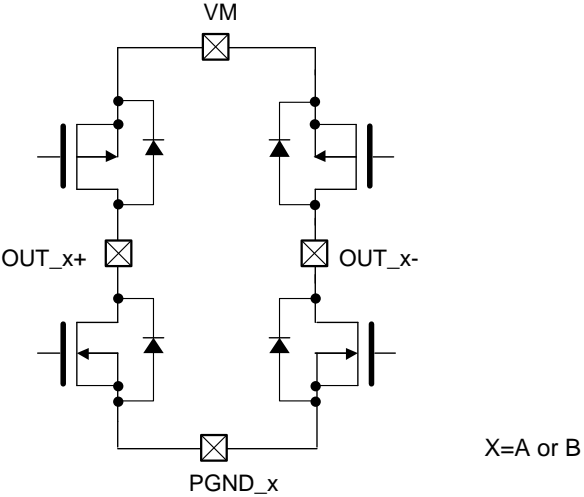
Pin name	Equivalent circuit
IN1A / Phase A IN2A / Phase B IN1B / Enable A IN2B / Enable B STBY	
MODE / ERR	
VREF	
OSCM	
OUT_A+ OUT_A- OUT_B+ OUT_B- PGND_A PGND_B	

Note: The equivalent circuit diagrams may be simplified for explanatory purposes.

7. Control Mode Select Function

The MODE pin can be selected IN input mode or PHASE input mode.
 The control mode is set up by the input state of the MODE pin after releasing standby mode.

MODE pin input	Function
L	IN input mode
H	PHASE input mode

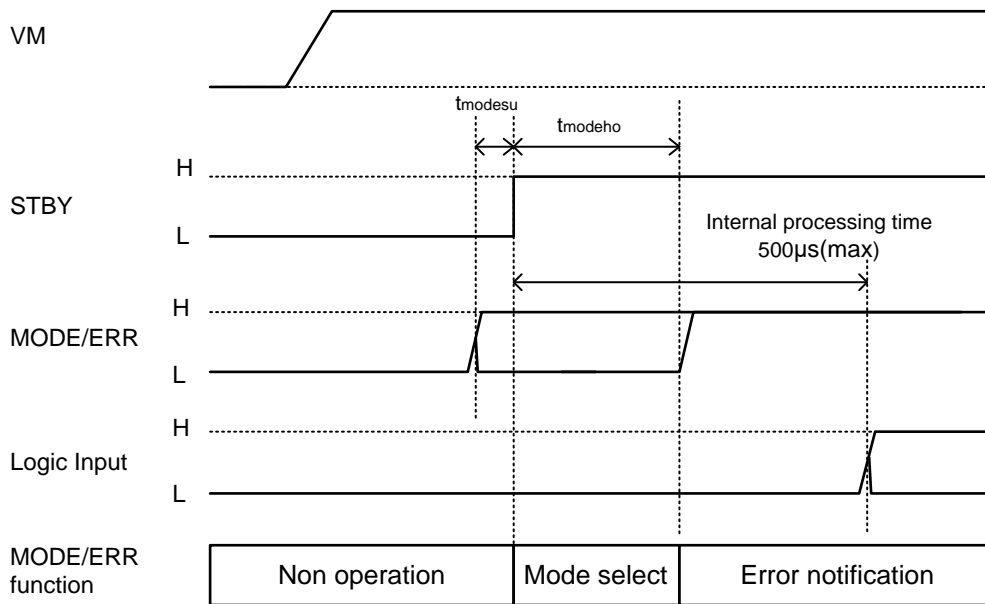

Characteristics	Symbol	Test condition	Min	Typ.	Max	Unit
Mode select Setup time	t_{modesu}	To STBY edge	1	—	—	µs
Mode select Data hold time	t_{modeho}	From STBY edge	100	—	—	µs

Note: When using Phase input mode (MODE=H) or Error function, please set the MODE/ERR pin to High level via a pull-up resistor.

8. Functional Description

8.1. IN Input Mode (MODE=L)

STBY	IN1A	IN2A	IN1B	IN2B	OUT_A+	OUT_A-	OUT_B+	OUT_B-	Mode
H	H	H	H	H	L	L	L	L	Short brake
H	H	L	—	—	H	L	—	—	Forward
H	L	H	—	—	L	H	—	—	Reverse
H	—	—	H	L	—	—	H	L	Forward
H	—	—	L	H	—	—	L	H	Reverse
H	L	L	L	L	Hi-Z	Hi-Z	Hi-Z	Hi-Z	Stop
L	—	—	—	—	Hi-Z	Hi-Z	Hi-Z	Hi-Z	Standby

Note: Current path; Forward rotation (OUT_X+ to OUT_X-), Reverse rotation (OUT_X- to OUT_X+). X = A or B.

Note: Dual H-Bridge can be programmed and operate simultaneously.

Note: — are Don't Care.

8.2. Phase Input Mode (MODE=H)

STBY	Phase A	Enable A	Phase B	Enable B	OUT_A+	OUT_A-	OUT_B+	OUT_B-	Mode
H	H	H	—	—	H	L	—	—	Forward
H	L	H	—	—	L	H	—	—	Reverse
H	—	—	H	H	—	—	H	L	Forward
H	—	—	L	H	—	—	L	H	Reverse
H	—	L	—	L	Hi-Z	Hi-Z	Hi-Z	Hi-Z	Stop
L	—	—	—	—	Hi-Z	Hi-Z	Hi-Z	Hi-Z	Standby

Note: Current path; Forward rotation (OUT_X+ to OUT_X-), Reverse rotation (OUT_X- to OUT_X+). X = A or B.

Note: Dual H-Bridge can be programmed and operate simultaneously.

Note: — are Don't Care.

9. Constant Current Control

In the case of constant current control, the rate of Mixed Decay mode which determines the current ripple is fixed to 37.5%.

Peak current is set by the voltage value of VREF pin.

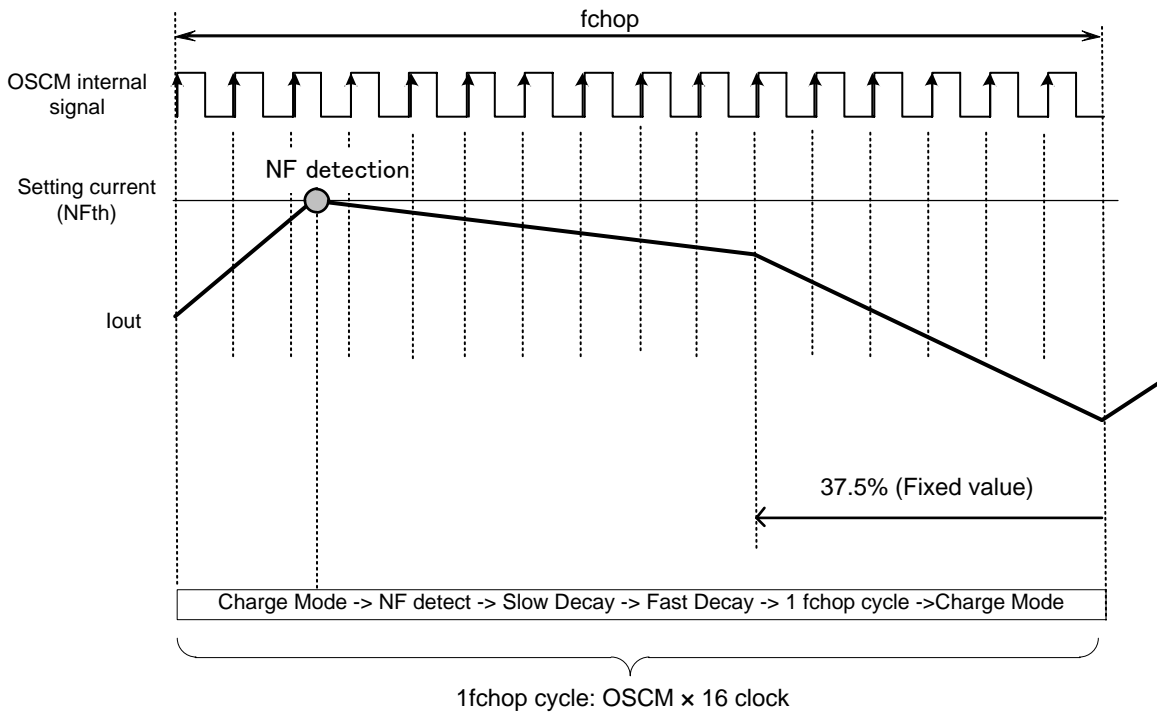

Note: The blanking time (AtBLK) is also set to prevent an incorrect operation in the NF detection (the motor current reaches the set current value (NFth)).

Note: Timing charts may be simplified for explanatory purpose.

9.1. Calculation of the Predefined Output Current

The peak output current (Setting current value) can be set via the reference voltage (Vref), as follows:

$$I_{out} (Max) = 1.1 \times V_{ref} (V)$$

9.2. Constant Current PWM Function and Timing

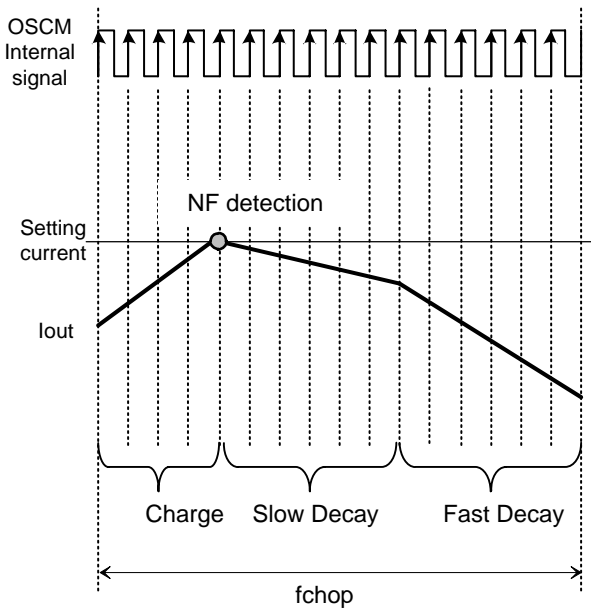

If the NF is detected during the early timing of the fchop cycle, the Slow Decay will be longer.

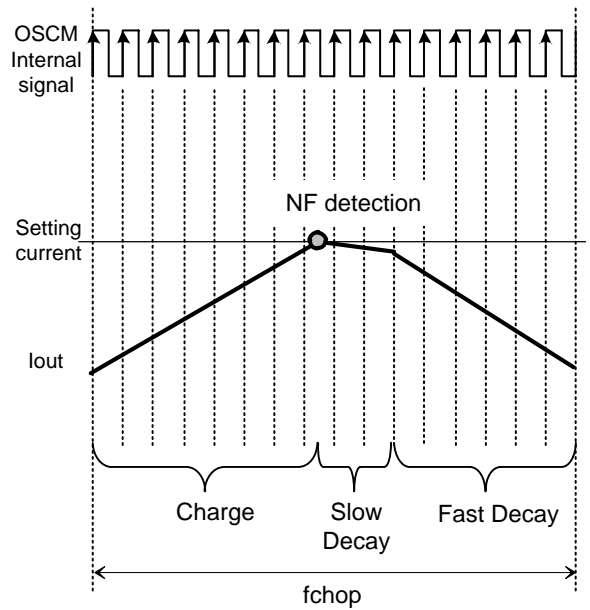

If the NF is detected during the late timing of the fchop cycle, the Slow Decay will be shorter.

The Charge period (the time until the motor current reaches the set current value) is determined by the operating status. Therefore the NF detection timing (the motor current reaches the set current value) with the chopping cycle (fchop) may change. If NF is detected in the early period of the fchop cycle, the Slow Decay will be longer. If NF is detected in the late period of the fchop cycle, the Slow Decay will be shorter, as shown above.

Note: The chopping cycle is determined as: $f_{chop} - (\text{Charge} + \text{Fast Decay}) = \text{Slow Decay}$

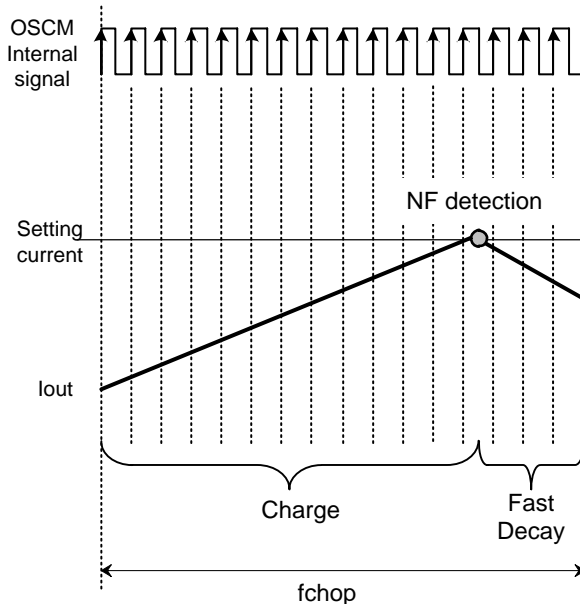

If NF detection is overdue, Decay sequence will only be Fast Decay. (Slow Decay does not appear.)

Note: Timing charts may be simplified for explanatory purpose.

9.3. Mixed Decay Current Waveform

- When the next current step is higher:

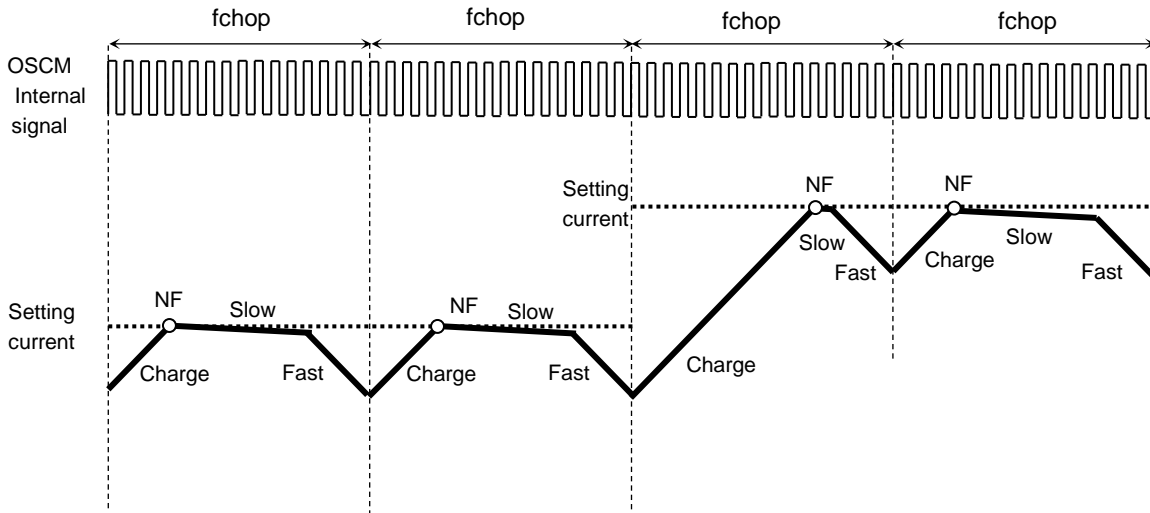

- When Charge Period is More Than 1 fchop Cycle:

When the Charge period is longer than fchop cycle, the Charge period extends until the motor current reaches the NF threshold. Once the current reaches the next current step, then the sequence goes on to Decay mode.

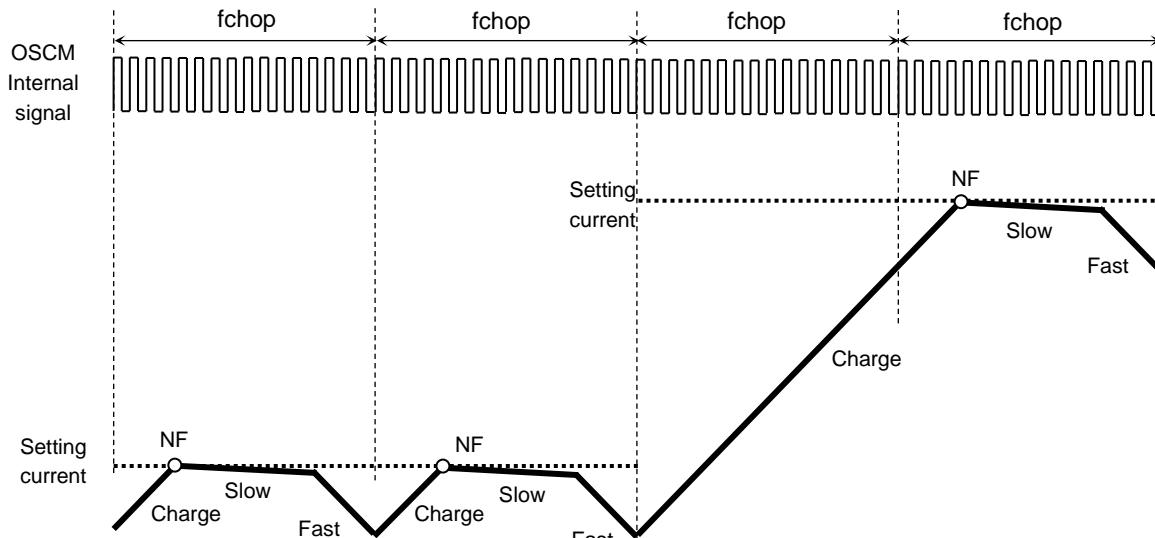

- When the Next Current Step is Lower:

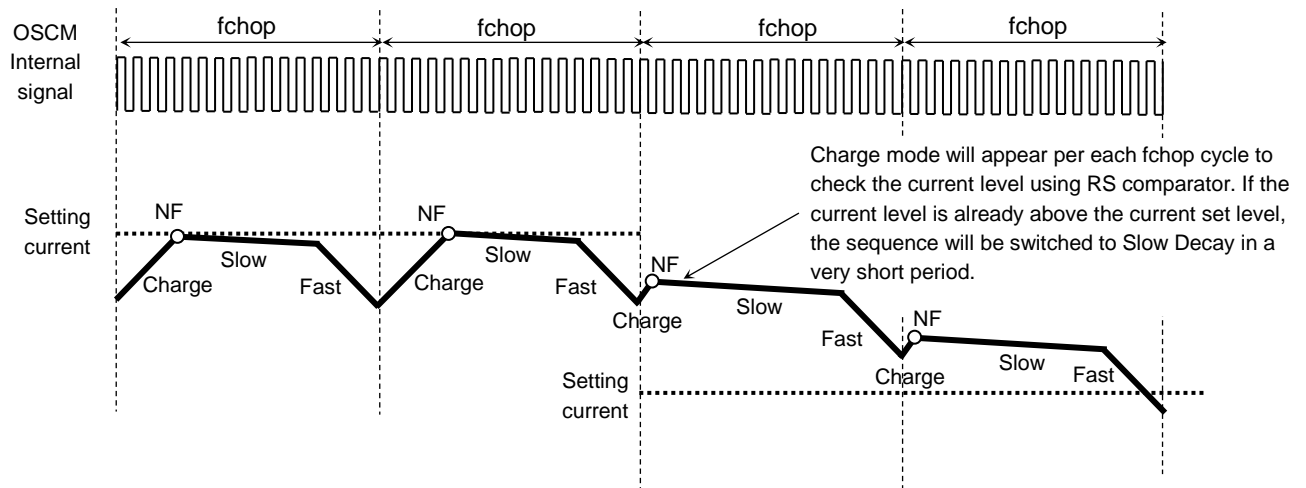

Note: Timing charts may be simplified for explanatory purpose.

10. Error Function (Error Detect Flag Output)

When TC78H660FNG detects some errors, ERR pin outputs low level to peripheral block.

Since ERR pin and MODE pin share the function, the below peripheral circuit between TC78H660FNG and HOST MCU should be inserted. In normal status, since the internal MOSFET is OFF, the level of ERR pin is equal to the MODE control voltage from outside. When the thermal shutdown (TSD), Over current (ISD), occurs, ERR pin will become Low (the internal MOSFET is ON). When using this function, please set the MODE/ERR pin to High level with a pull-up resistor after setting up control mode.

When the error detection is released by reasserting the VM power supply or setting the device to STANDBY mode, ERR pins show “normal status”.

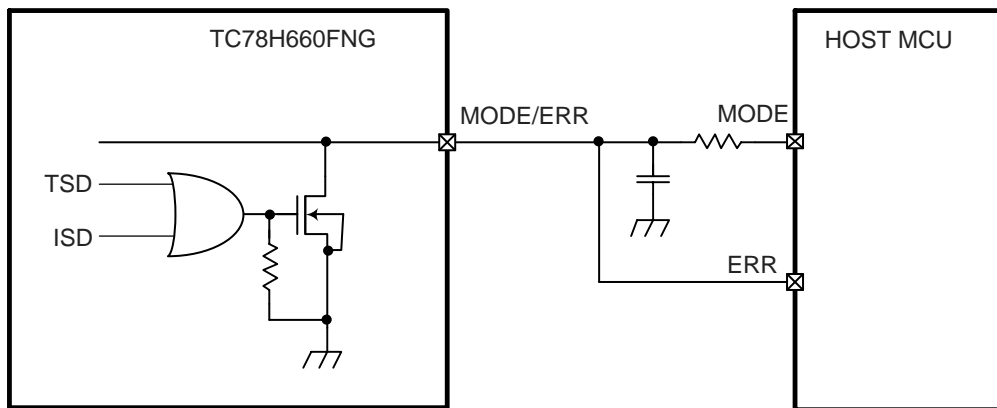

Note: This figure may be simplified for explanatory purpose.

ERR pin output	Function
H (Pull-up)	Normal status (Normal operation)
L	Detect error status (ISD or TSD)

After detecting TSD detection: TC78H660FNG draws out currents of motor by Fast mode. If the output current is zero-detected or for 1ms at maximum, the output becomes Hi-Z.

After detecting ISD detection: In H Bridge high side (Pch DMOS) detection, TC78H660FNG draws out currents of motor by low side Slow mode. The output after 80 ms becomes Hi-Z. In H Bridge low side (Nch DMOS) detection, it draws out by high side Slow mode.

Note: Above times are reference values, and are not guaranteed.

11. Standby Function

It is possible to switch to Standby mode by STBY pin. .

STBY pin input	Function
L	Standby mode
H	Normal mode

Note: When STBY pin is Low, TC78H660FNG stops supplying the power to logic circuit.

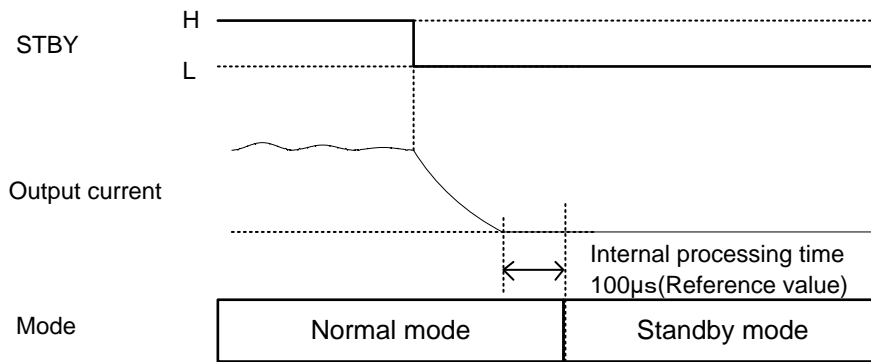

If the output current is zero-detected, the operation mode enters into the standby mode after 100µs. The mode enters into the standby mode forcedly after 1 ms(max) from STBY=L.

Note: Above times are reference values, and are not guaranteed.

12. Output Transistor Function Mode

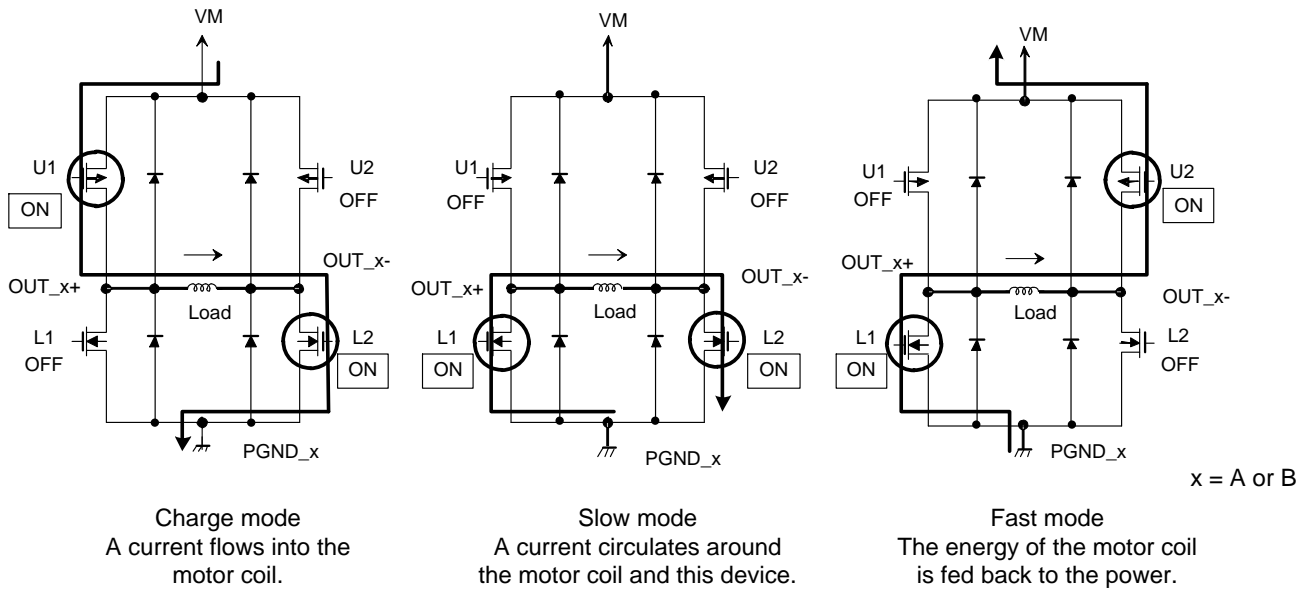

Note: The equivalent circuit diagrams may be simplified or some parts of them may be omitted for explanatory purposes.

12.1. Output Transistor Function

MODE	U1	U2	L1	L2
Charge	ON	OFF	OFF	ON
Slow	OFF	OFF	ON	ON
Fast	OFF	ON	ON	OFF

Note: This table shows an example of when the current flows as indicated by the arrows in the figures shown above. If the current flows in the opposite direction, refer to the following table.

MODE	U1	U2	L1	L2
Charge	OFF	ON	ON	OFF
Slow	OFF	OFF	ON	ON
Fast	ON	OFF	OFF	ON

This IC controls the motor current to be constant by changing 3 modes listed above automatically

Note: To eliminate shoot-through current that flows from supply to ground due to the simultaneous conduction of high side and low side transistors in the bridge output, a dead time (100ns (Reference value)) is generated in this IC when transistors switch from on to off, or vice versa.

13. OSCM Oscillation Frequency and Chopping Frequency

The OSCM oscillation frequency (f_{OSCM}) and chopping frequency (f_{chop}) can be adjusted by the external resistor (ROSC) connecting to OSCM pin.

ROSC[k Ω]	f_{OSCM} [kHz](typ.)	f_{chop} [kHz](typ.)
18	3290	206
22	2691	168
30	1982	124
39	1526	95
47	1266	79
56	1064	66
75	795	50
91	656	41

If chopping frequency is raised, Ripple of current will become small and wave-like reproducibility will improve.

However, the gate loss inside IC goes up and generation of heat becomes large.

By lowering chopping frequency, reduction in generation of heat is expectable. However, ripple of current may become large.

It is a standard about 70 kHz. A setup in the range of 50 kHz to 100 kHz is recommended.

14. Absolute Maximum Ratings (Ta = 25°C)

Characteristics	Symbol	Rating	Unit	Remarks
Motor output voltage	Vout	20	V	Outputs are OFF
		18	V	Outputs are ON
Motor power supply (non-active)	VM	20	V	STBY pin = L
Motor power supply (active)		-0.4 to 18	V	STBY pin = H
Motor output current	Iout	2.0	A	(Note 1)
Logic input voltage	VIN(H)	6.0	V	—
	VIN(L)	-0.4	V	—
ERR output pin voltage	VLO	6.0	V	—
ERR output pin inflow current	ILO	6.0	mA	—
Power dissipation	P _D	0.78	W	(Note 2)
Operating temperature	Topr	-40 to 85	°C	—
Storage temperature	Tstg	-55 to 150	°C	—
Junction temperature	Tj(max)	150	°C	—

Note1: Usually, the maximum current value at the time should use 70% or less of the absolute maximum ratings for a standard on thermal rating. The maximum output current may be further limited in view of thermal considerations, depending on ambient temperature and board conditions.

Note2: When mounted on a single-side glass epoxy board
(50 mm × 50 mm × 1.6 mm, Cu area: 40%, Cu thick: 35 μm)

Ta: Ambient temperature

Topr: Ambient temperature while the IC is active

Tj: Junction temperature while the IC is active.

The maximum junction temperature is limited by the thermal shutdown (TSD) circuitry. It is advisable to keep the maximum current below a certain level so that the maximum junction temperature, Tj (MAX), will not exceed 120°C.

Caution) Absolute maximum ratings

The absolute maximum ratings of a semiconductor device are a set of ratings that must not be exceeded, even for a moment. Do not exceed any of these ratings. Exceeding the rating (s) may cause device breakdown, damage or deterioration, and may result in injury by explosion or combustion.

The value of even one parameter of the absolute maximum ratings should not be exceeded under any circumstances. The TC78H660FNG does not have overvoltage detection circuit. Therefore, the device is damaged if a voltage exceeding its rated maximum is applied.

All voltage ratings, including supply voltages, must always be followed. The other notes and considerations described later should also be referred to.

15. Operating Range (Ta = -40 to 85°C)

Characteristics	Symbol	Min	Typ.	Max	Unit	Remarks
Motor power supply	VM	2.5	—	16.0	V	—
Motor output current	Iout	—	1.1	2.0	A	(Note1)
ERR pin output voltage	VLO	—	—	5.5	V	—
Vref reference voltage	Vref	0	—	1.8	V	—
PWM frequency	fPWM	—	—	400	kHz	Duty=50%

Note1: The actual maximum current may be limited by the operating environment (operating conditions such as operating duration, or by the surrounding temperature or board heat dissipation). Determine a realistic maximum current by calculating the heat generated under the operating environment.

16. Electrical Specifications 1

(Ta = 25°C, VM = 2.5 to 16V unless otherwise specified)

Characteristics		Symbol	Test condition	Min	Typ.	Max	Unit
Logic input voltage	HIGH	VIN(H)	Logic input (Note1)	1.5	—	5.5	V
	LOW	VIN(L)	Logic input (Note1)	0	—	0.7	V
Logic input hysteresis voltage		VIN(HYS)	Logic input (Note1)	—	60	—	mV
Logic input current	HIGH	IIN(H)	VIN(H) = 3.3 V	—	33	45	μA
	LOW	IIN(L)	VIN(L) = 0 V	—	—	1	μA
ERR pin output voltage	LOW	VOL(LO)	IOL = 5 mA, output = L	—	—	0.5	V
Current consumption		IM1	Output pins = open Standby mode	—	—	0.1	μA
		IM2	Output pins = open Stop mode in releasing Standby mode	—	2.8	3.5	mA
		IM3	Output pins = open fPWM = 18.75 kHz	—	3.3	4.3	mA
Output leakage current	High-side	IOH	VM = 18 V, Vout = 0 V	—	—	1	μA
	Low-side	IOL	VM = Vout = 18 V	-1	—	—	μA
Motor current channel differential		ΔIout1	Current differential between Ch	-5	0	5	%
Motor current setting accuracy		ΔIout2	Iout = 1.1 A	-10	0	10	%
Motor output ON resistance (High side + Low side)		Ron(H+L)	Tj = 25°C, VM = 12 V, Iout = 1 A	—	0.48	0.6	Ω

Note: When the logic signal is applied to the device whilst the VM power supply is not asserted; the device is designed not to function, but for safe usage, please apply the logic signal after the VM power supply is asserted and the VM voltage reaches the proper operating range.

Note1: VIN(H) is defined as the VIN voltage that causes the outputs (OUT_A+ pin, OUT_A- pin, OUT_B+ pin, OUT_B- pin) to change when a pin under test is gradually raised from 0 V. VIN(L) is defined as the VIN voltage that causes the outputs (OUT_A+ pin, OUT_A- pin, OUT_B+ pin, OUT_B- pin) to change when the pin is then gradually lowered from 5 V. The difference between VIN(H) and VIN(L) is defined as the VIN(HYS).

17. Electrical Specifications 2

($T_a = 25^\circ\text{C}$, $V_M = 2.5$ to 16V unless otherwise specified)

Characteristics	Symbol	Test condition	Min	Typ.	Max	Unit
Vref input current	Iref	Vref = 1.8 V	—	0	1	μA
Thermal shutdown (TSD) threshold (Note 1)	TjTSD	—	145	165	175	°C
UVLO release voltage (Note 2)	VUVLO	At rising VM	2.1	2.3	—	V
UVLO hysteresis voltage	Vhys_uvlo	—	—	200	—	mV
Over current detection (ISD) threshold (Note 3)	ISD	VM = 12 V	2.5	3.2	4.2	A

Note1: Thermal shutdown (TSD)

When the junction temperature of the device reaches the TSD threshold, the TSD circuit is triggered; the internal reset circuit then turns off the output transistors. Once the TSD circuit is triggered, the device will set output pin to Hi-Z, and can be cleared by reasserting the VM power source, or setting the STBY pins to standby mode. The TSD circuit is a backup function to detect a thermal error, therefore is not recommended to be used aggressively.

Note 2: Under voltage lockout (UVLO)

When the supply voltage to VM pin is 2.1 V or less (typ.), the internal circuit is triggered; the internal reset circuit then turns off the output transistors. Once the UVLO is triggered, it can be cleared by reasserting the VM supply voltage to 2.3 V or more (typ.)

Note3: Over current detection (ISD)

When the output current reaches the threshold, the ISD circuit is triggered; the internal reset circuit then turns off the output transistors. It has a dead band time of 1.2 μs (typ.) to avoid ISD false triggering by switching noise. Once the ISD circuit is triggered, the device will set output pins to Hi-Z, and can be cleared by reasserting the VM power source, or setting the STBY pin to standby mode.

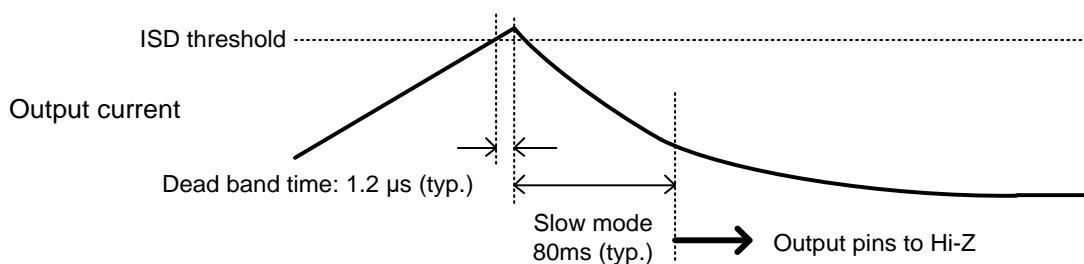
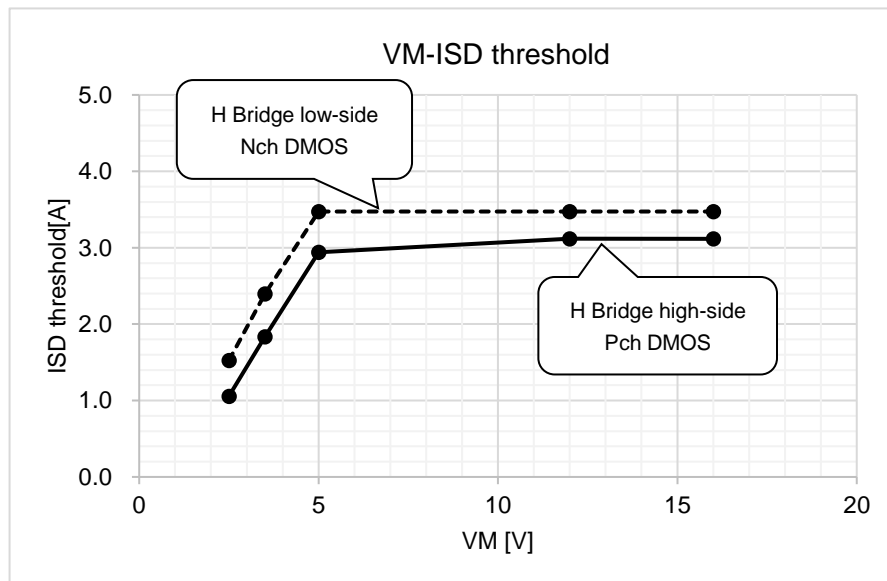

Note: Above ISD operation threshold value and band times are reference values, and are not guaranteed.

Back-EMF

While a motor is rotating, there is a timing at which power is fed back to the power supply. At that timing, the motor current recirculates back to the power supply due to the effect of the motor back-EMF.

If the power supply does not have enough sink capability, the power supply and output pins of the device might rise above the rated voltages. The magnitude of the motor back-EMF varies with usage conditions and motor characteristics. It must be fully verified that there is no risk that the TC78H660FNG or other components will be damaged or fail due to the motor back-EMF.

Cautions on Overcurrent Shutdown (ISD) and Thermal Shutdown (TSD)

The ISD and TSD circuits are only intended to provide temporary protection against irregular conditions such as an output short-circuit; they do not necessarily guarantee the complete IC safety.

If the device is used beyond the specified operating ranges, these circuits may not operate properly: then the device may be damaged due to an output short-circuit.

The ISD circuit is only intended to provide a temporary protection against an output short-circuit. If such a condition persists for a long time, the device may be damaged due to overstress. Overcurrent conditions must be removed immediately by external hardware.

IC Mounting

Do not insert devices incorrectly or in the wrong orientation. Otherwise, it may cause breakdown, damage and/or deterioration of the device.

18. AC Electrical Specification

(Ta = 25°C, VM = 12V, 6.8 mH/5.7 Ω unless otherwise specified)

Characteristics	Symbol	Test condition	Min	Typ.	Max	Unit
Logic input pulse width	tw(H)	—	500	—	—	ns
	tw(L)	—	500	—	—	ns
Output transistor switching specific	tr	—	10	20	30	ns
	tf	—	10	20	30	ns
	tpLH	—	—	840	—	ns
	tpHL	—	—	900	—	ns
Analog noise blanking time	AtBLK	VM = 12 V	340	540	740	ns
Oscillator frequency accuracy	ΔfOSCM	ROSC = 47 kΩ VM = 2.5 V to 16 V	-15	—	+15	%
Oscillator reference frequency	fOSCM	ROSC = 47 kΩ	1076	1266	1456	kHz
Chopping frequency	fchop	Output: Active, fOSCM = 1266 kHz	—	79	—	kHz

AC Electrical Specification Timing chart

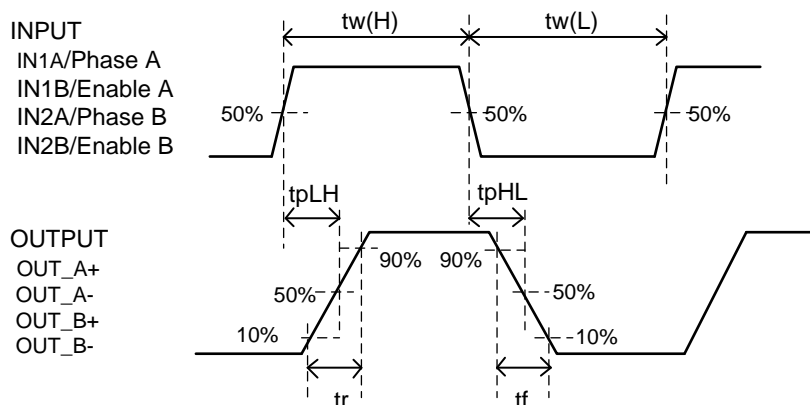

Note: Timing charts may be simplified for explanatory purpose.

19. (Reference data) P_D - T_a Characteristics

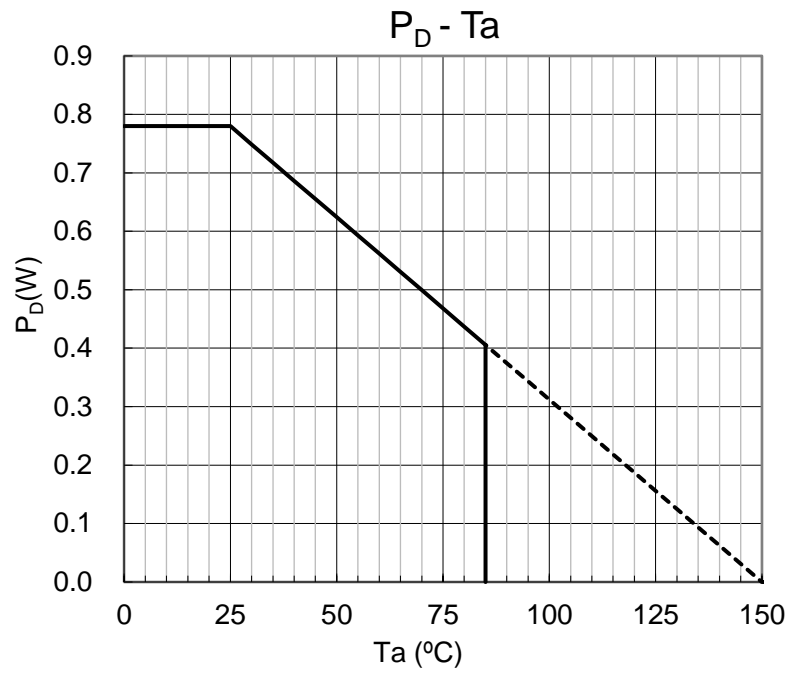

When mounted on a single-side glass epoxy board (50 mm × 50 mm × 1.6 mm, Cu area: 40%, Cu thick: 35 μm)

Note: Characteristics shown above are reference values and not guaranteed.

20. Application Circuit Example

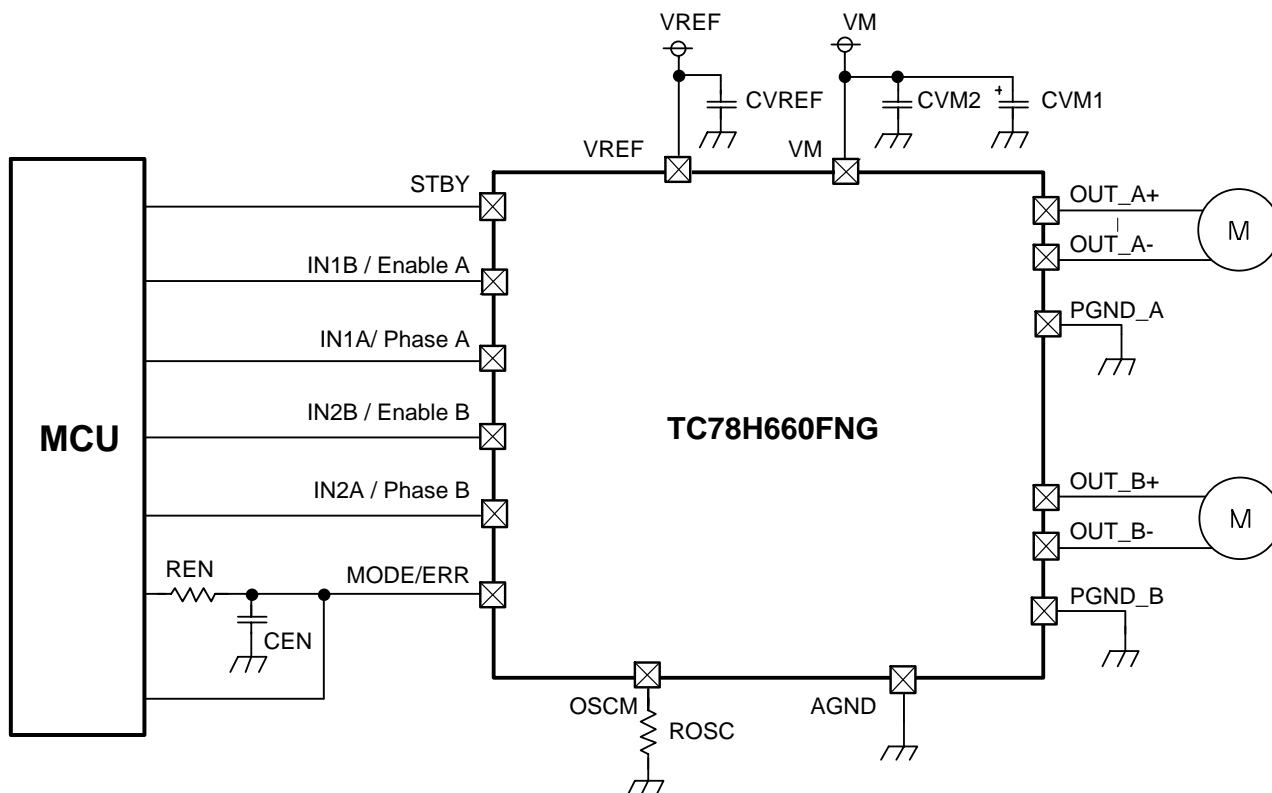

The application circuit shown in this document is provided for reference purposes only. The data for mass production are not guaranteed.

Component values (for reference only)

Part's symbol	Component	Value
CVM1	Electrolytic capacitor	47 μ F
CVM2	Ceramic capacitor	0.1 μ F
CVREF	Ceramic capacitor	0.1 μ F
CEN	Ceramic capacitor	22 nF
ROSC	Resistor	47 k Ω
REN	Resistor	10 k Ω

Note: Component values in above table are for reference only. Some components other than reference value can be adopted depending on the usage conditions.

21. Package Dimensions

P-TSSOP16-0505-0.65-001

Unit: mm

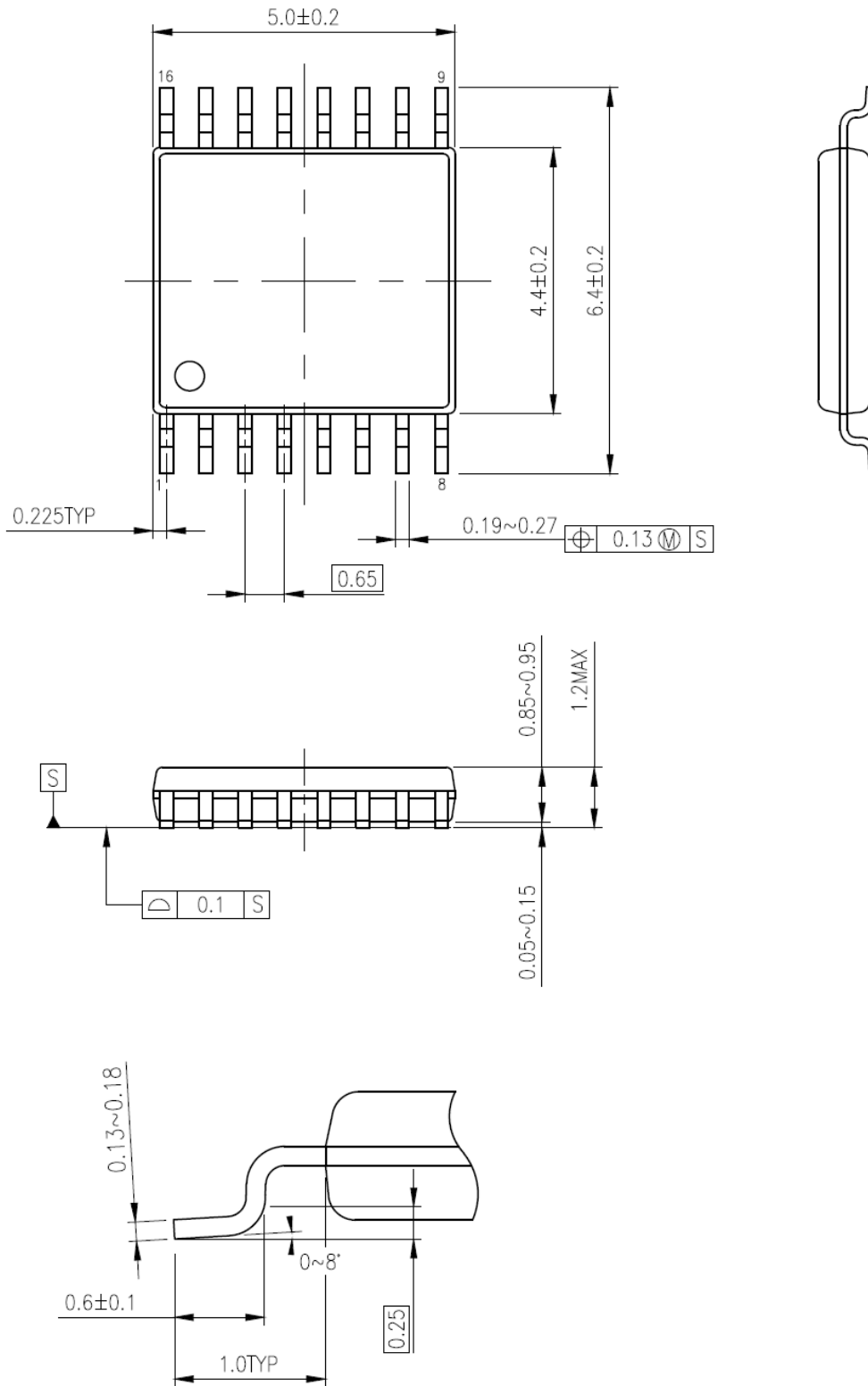

Weight: 56.5 mg (typ.)

Notes on Contents

1. Block Diagrams

Some of the functional blocks, circuits, or constants in the block diagram may be omitted or simplified for explanatory purposes.

2. Equivalent Circuits

The equivalent circuit diagrams may be simplified or some parts of them may be omitted for explanatory purposes.

3. Timing Charts

Timing charts may be simplified for explanatory purposes.

4. Application Circuits

The application circuits shown in this document are provided for reference purposes only. Thorough evaluation is required, especially at the mass production design stage.

Providing these application circuit examples does not grant a license for industrial property rights.

IC Usage Considerations**Notes on handling of ICs**

- (1) The absolute maximum ratings of a semiconductor device are a set of ratings that must not be exceeded, even for a moment. Do not exceed any of these ratings.
Exceeding the rating(s) may cause the device breakdown, damage or deterioration, and may result injury by explosion or combustion.

- (2) Use an appropriate power supply fuse to ensure that a large current does not continuously flow in case of over current and/or IC failure. The IC will fully break down when used under conditions that exceed its absolute maximum ratings, when the wiring is routed improperly or when an abnormal pulse noise occurs from the wiring or load, causing a large current to continuously flow and the breakdown can lead smoke or ignition. To minimize the effects of the flow of a large current in case of breakdown, appropriate settings, such as fuse capacity, fusing time and insertion circuit location, are required.

- (3) If your design includes an inductive load such as a motor coil, incorporate a protection circuit into the design to prevent device malfunction or breakdown caused by the current resulting from the inrush current at power ON or the negative current resulting from the back electromotive force at power OFF. IC breakdown may cause injury, smoke or ignition. Use a stable power supply with ICs with built-in protection functions. If the power supply is unstable, the protection function may not operate, causing IC breakdown. IC breakdown may cause injury, smoke or ignition.

- (4) Do not insert devices in the wrong orientation or incorrectly.
Make sure that the positive and negative terminals of power supplies are connected properly. Otherwise, the current or power consumption may exceed the absolute maximum rating, and exceeding the rating(s) may cause the device breakdown, damage or deterioration, and may result injury by explosion or combustion. In addition, do not use any device that is applied the current with inserting in the wrong orientation or incorrectly even just one time.

- (5) Carefully select external components (such as inputs and negative feedback capacitors) and load components (such as speakers), for example, power amp and regulator. If there is a large amount of leakage current such as from input or negative feedback condenser, the IC output DC voltage will increase. If this output voltage is connected to a speaker with low input withstand voltage, overcurrent or IC failure may cause smoke or ignition. (The overcurrent may cause smoke or ignition from the IC itself.) In particular, please pay attention when using a Bridge Tied Load (BTL) connection-type IC that inputs output DC voltage to a speaker directly.

Points to remember on handling of ICs**(1) Over current Protection Circuit**

Over current protection circuits (referred to as current limiter circuits) do not necessarily protect ICs under all circumstances. If the Over current protection circuits operate against the over current, clear the over current status immediately.

Depending on the method of use and usage conditions, such as exceeding absolute maximum ratings can cause the over current protection circuit to not operate properly or IC breakdown before operation. In addition, depending on the method of use and usage conditions, if over current continues to flow for a long time after operation, the IC may generate heat resulting in breakdown.

(2) Thermal Shutdown Circuit

Thermal shutdown circuits do not necessarily protect ICs under all circumstances. If the thermal shutdown circuits operate against the over temperature, clear the heat generation status immediately.

Depending on the method of use and usage conditions, such as exceeding absolute maximum ratings can cause the thermal shutdown circuit to not operate properly or IC breakdown before operation.

(3) Heat Radiation Design

In using an IC with large current flow such as power amp, regulator or driver, please design the device so that heat is appropriately radiated, not to exceed the specified junction temperature (T_j) at any time and condition.

These ICs generate heat even during normal use. An inadequate IC heat radiation design can lead to decrease in IC life, deterioration of IC characteristics or IC breakdown. In addition, please design the device taking into consideration the effect of IC heat radiation with peripheral components.

(4) Back-EMF

When a motor reverses the rotation direction, stops or slows down abruptly, a current flow back to the motor's power supply due to the effect of back-EMF. If the current sink capability of the power supply is small, the device's motor power supply and output pins might be exposed to conditions beyond absolute maximum ratings. To avoid this problem, take the effect of back-EMF into consideration in system design.

RESTRICTIONS ON PRODUCT USE

Toshiba Corporation and its subsidiaries and affiliates are collectively referred to as "TOSHIBA".

Hardware, software and systems described in this document are collectively referred to as "Product".

- TOSHIBA reserves the right to make changes to the information in this document and related Product without notice.
- This document and any information herein may not be reproduced without prior written permission from TOSHIBA. Even with TOSHIBA's written permission, reproduction is permissible only if reproduction is without alteration/omission.
- Though TOSHIBA works continually to improve Product's quality and reliability, Product can malfunction or fail. Customers are responsible for complying with safety standards and for providing adequate designs and safeguards for their hardware, software and systems which minimize risk and avoid situations in which a malfunction or failure of Product could cause loss of human life, bodily injury or damage to property, including data loss or corruption. Before customers use the Product, create designs including the Product, or incorporate the Product into their own applications, customers must also refer to and comply with (a) the latest versions of all relevant TOSHIBA information, including without limitation, this document, the specifications, the data sheets and application notes for Product and the precautions and conditions set forth in the "TOSHIBA Semiconductor Reliability Handbook" and (b) the instructions for the application with which the Product will be used with or for. Customers are solely responsible for all aspects of their own product design or applications, including but not limited to (a) determining the appropriateness of the use of this Product in such design or applications; (b) evaluating and determining the applicability of any information contained in this document, or in charts, diagrams, programs, algorithms, sample application circuits, or any other referenced documents; and (c) validating all operating parameters for such designs and applications. **TOSHIBA ASSUMES NO LIABILITY FOR CUSTOMERS' PRODUCT DESIGN OR APPLICATIONS.**
- **PRODUCT IS NEITHER INTENDED NOR WARRANTED FOR USE IN EQUIPMENTS OR SYSTEMS THAT REQUIRE EXTRAORDINARILY HIGH LEVELS OF QUALITY AND/OR RELIABILITY, AND/OR A MALFUNCTION OR FAILURE OF WHICH MAY CAUSE LOSS OF HUMAN LIFE, BODILY INJURY, SERIOUS PROPERTY DAMAGE AND/OR SERIOUS PUBLIC IMPACT ("UNINTENDED USE").** Except for specific applications as expressly stated in this document, Unintended Use includes, without limitation, equipment used in nuclear facilities, equipment used in the aerospace industry, Class 3 medical devices, equipment used for automobiles, and military vehicles and munitions. **IF YOU USE PRODUCT FOR UNINTENDED USE, TOSHIBA ASSUMES NO LIABILITY FOR PRODUCT.** For details, please contact your TOSHIBA sales representative or contact us via our website.
- Do not disassemble, analyze, reverse-engineer, alter, modify, translate or copy Product, whether in whole or in part.
- Product shall not be used for or incorporated into any products or systems whose manufacture, use, or sale is prohibited under any applicable laws or regulations.
- The information contained herein is presented only as guidance for Product use. No responsibility is assumed by TOSHIBA for any infringement of patents or any other intellectual property rights of third parties that may result from the use of Product. No license to any intellectual property right is granted by this document, whether express or implied, by estoppel or otherwise.
- **ABSENT A WRITTEN SIGNED AGREEMENT, EXCEPT AS PROVIDED IN THE RELEVANT TERMS AND CONDITIONS OF SALE FOR PRODUCT, AND TO THE MAXIMUM EXTENT ALLOWABLE BY LAW, TOSHIBA (1) ASSUMES NO LIABILITY WHATSOEVER, INCLUDING WITHOUT LIMITATION, INDIRECT, CONSEQUENTIAL, SPECIAL, OR INCIDENTAL DAMAGES OR LOSS, INCLUDING WITHOUT LIMITATION, LOSS OF PROFITS, LOSS OF OPPORTUNITIES, BUSINESS INTERRUPTION AND LOSS OF DATA, AND (2) DISCLAIMS ANY AND ALL EXPRESS OR IMPLIED WARRANTIES AND CONDITIONS RELATED TO SALE, USE OF PRODUCT, OR INFORMATION, INCLUDING WARRANTIES OR CONDITIONS OF MERCHANTABILITY, FITNESS FOR A PARTICULAR PURPOSE, ACCURACY OF INFORMATION, OR NONINFRINGEMENT.**
- Do not use or otherwise make available Product or related software or technology for any military purposes, including without limitation, for the design, development, use, stockpiling or manufacturing of nuclear, chemical, or biological weapons or missile technology products (mass destruction weapons). Product and related software and technology may be controlled under the applicable export laws and regulations including, without limitation, the Japanese Foreign Exchange and Foreign Trade Law and the U.S. Export Administration Regulations. Export and re-export of Product or related software or technology are strictly prohibited except in compliance with all applicable export laws and regulations.
- Please contact your TOSHIBA sales representative for details as to environmental matters such as the RoHS compatibility of Product. Please use Product in compliance with all applicable laws and regulations that regulate the inclusion or use of controlled substances, including without limitation, the EU RoHS Directive. **TOSHIBA ASSUMES NO LIABILITY FOR DAMAGES OR LOSSES OCCURRING AS A RESULT OF NONCOMPLIANCE WITH APPLICABLE LAWS AND REGULATIONS.**

TOSHIBA ELECTRONIC DEVICES & STORAGE CORPORATION

<https://toshiba.semicon-storage.com/>