

TOSHIBA CD process Integrated Circuit Silicon Monolithic

TC78H670FTG

Clock-in and Serial controlled Bipolar Stepping Motor Driver

1. Outline

The TC78H670FTG is a two-phase bipolar stepping motor driver using a PWM chopper which incorporate DMOS with low on-resistance in output transistors. The clock-in decoder is built in.

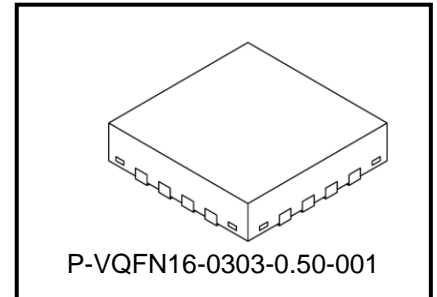

Weight: 22.9 mg (typ.)

2. Features

- Built-in Dual H Bridges, Capable of controlling 1 bipolar stepping motor
- PWM controlled constant-current drive
- Power supply operating voltage: 2.5 V to 16.0 V
- Output current ratings: 2.0 A (max)
- Low on-resistance (High + Low side = 0.48 Ω (typ.)) MOSFET output stage
- Allows full, half, quarter, 1/8, 1/16, 1/32, 1/64, 1/128 step operation
- Built-in Sense resistor less current control architecture (Advanced Current Detection System)
- Multi error detect functions (Thermal shutdown (TSD), Over current (ISD), motor load open (OPD) and Under voltage lockout(UVLO))
- Error detection (TSD/ISD/OPD) flag output function
- Built-in VCC regulator for internal circuit
- Chopping frequency of a motor can be adjusted by external resistor
- Small QFN package with thermal pad (16 pin)

Note: Please be careful about thermal conditions during using.

Note: It is possible to detect OPD only when Serial mode is selected.

Start of commercial production
2020-01

3. Pin Assignment

(Top View)

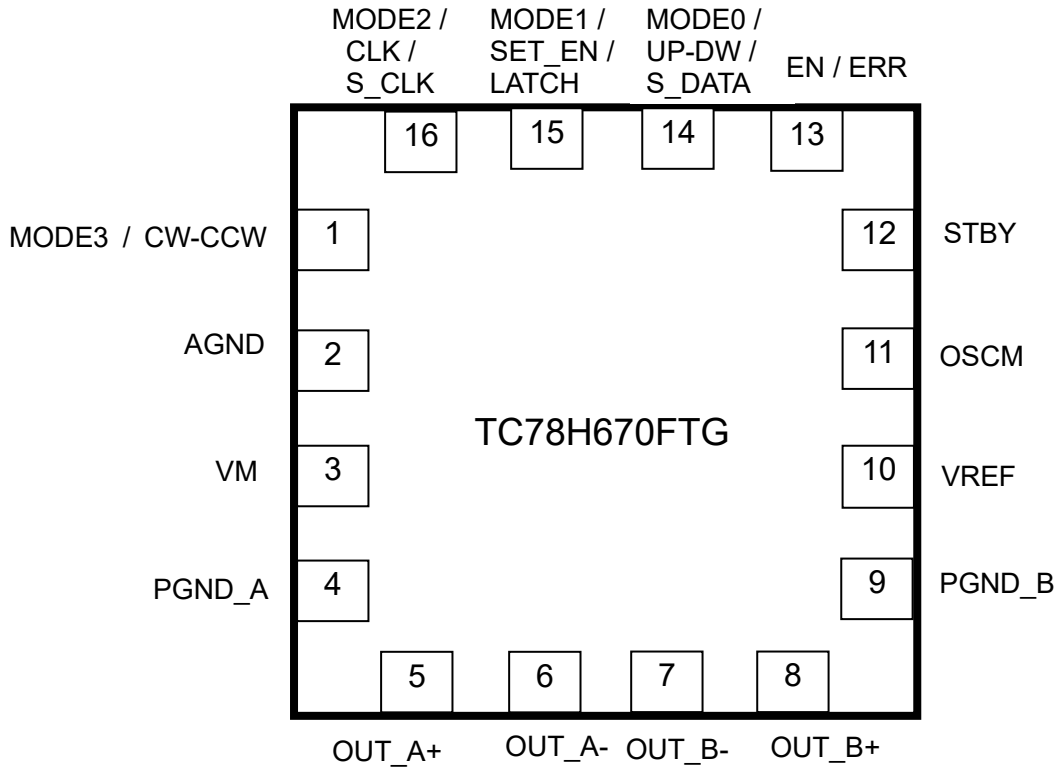

Figure3 Pin Assignment

Note: Please solder the corner pads and the rear thermal pad of the QFN package, to the GND pattern of the PCB.

4. Pin Description

Table4 Pin Description

Pin No.	STBY = Low	STBY = High		Pin description
		CLK-IN mode	Serial mode	
1	MODE3	CW-CCW	—	MODE3: Step mode select pin CW-CCW: Current direction setup pin
2	AGND	←	←	GND pin
3	VM	←	←	Motor power supply input pin
4	PGND_A	←	←	Ach Power GND pin
5	OUT_A+	←	←	A channel motor output(+) pin
6	OUT_A-	←	←	A channel motor output(-) pin
7	OUT_B-	←	←	B channel motor output(-) pin
8	OUT_B+	←	←	B channel motor output(+) pin
9	PGND_B	←	←	Bch Power GND pin
10	VREF	←	←	Current threshold reference pin
11	OSCM	←	←	Internal oscillator frequency setting pin
12	STBY	←	←	Standby pin
13	EN/ERR	←	←	Enable(Motor output ON/OFF) pin / Error detection flag output pin
14	MODE0	UP-DW	S_DATA	MODE0: Step mode select pin UP-DW: Step mode setting pin S_DATA: Serial data input pin
15	MODE1	SET_EN	LATCH	MODE1: Step mode select pin SET_EN: Step mode setting enable pin LATCH: Latch enable pin
16	MODE2	CLK	S_CLK	MODE2: Step mode select pin CLK: Step Clock input pin S_CLK: Serial clock input pin

5. Block Diagram

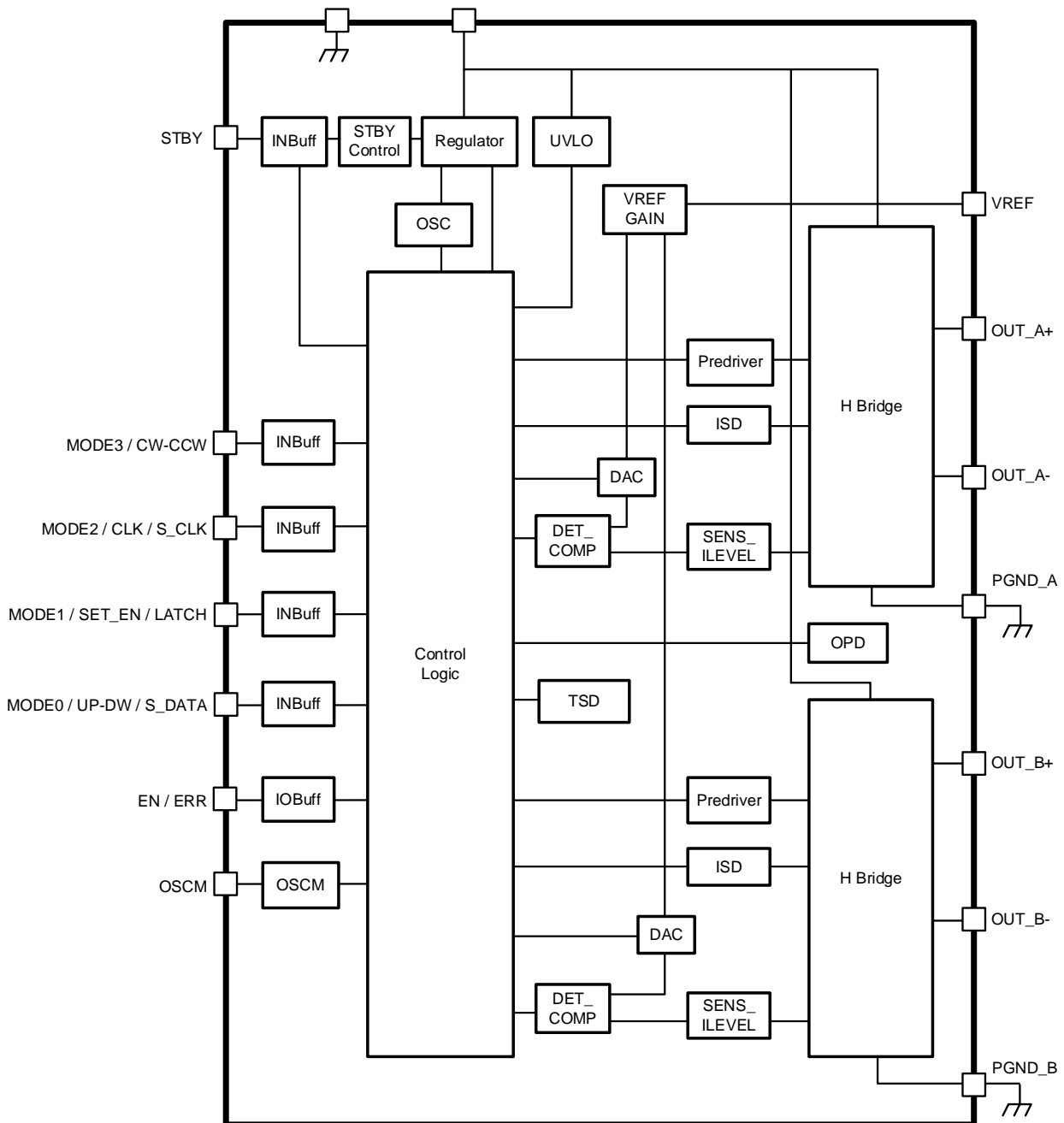

Figure 5 Block diagram

Note: Some of the functional blocks, circuits, or constants in the block diagram may be omitted or simplified for explanatory purpose.

Note: All the grounding wires should be solid patterns and be externally terminated at only one point. Also, a grounding method should be considered for efficient heat dissipation. Careful attention should be paid to the layout of the output, VM and GND traces, to avoid short circuits across output pins or to the power supply or ground. If such a short circuit occurs, the device may be permanently damaged. Also, the utmost care should be taken for pattern designing and implementation of the device since it has power supply pins (VM, AGND, PGND_x, OUT_x+ and OUT_x- (x = A or B)) through which a particularly large current may run. If these pins are wired incorrectly, an operation error may occur or the device may be destroyed. The logic input pins must also be wired correctly. Otherwise, the device may be damaged owing to a current running through the IC that is larger than the specified current. Careful attention should be paid to design patterns and mounting.

6. Input / Output Equivalent Circuit

Table 6 Input / Output Equivalent Circuit

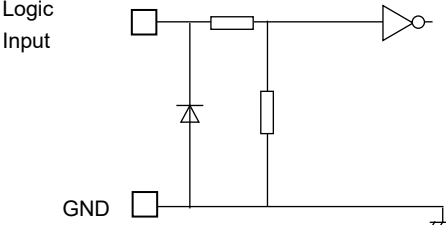
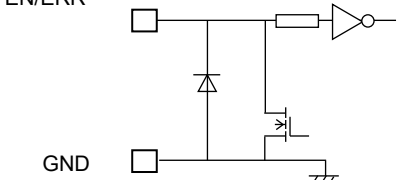
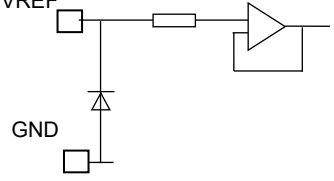
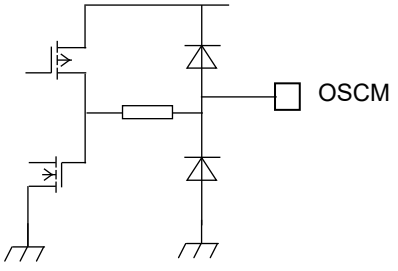
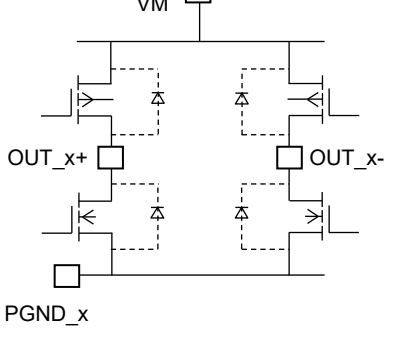
Pin name	Equivalent circuit
MODE3 / CW-CCW MODE2 / CLK / S_CLK MODE1 / SET_EN / LATCH MODE0 / UP-DW / S_DATA STBY	
EN / ERR	
VREF	
OSCM	
OUT_A+ OUT_A- OUT_B+ OUT_B- PGND_A PGND_B	

Note: The equivalent circuit diagrams may be simplified for explanatory purposes.

7. Control Mode Select Function

The MODE0-3 pins set Serial mode or CLK-IN mode.

The control mode is set up by the input state of the MODE0-3 pins after releasing standby mode.

Table 7.1 Control mode selection function 1

MODE3 pin input	MODE2 pin input	MODE1 pin input	MODE0 pin input	Function
L	L	L	L	Serial mode
Other than the above				CLK-IN mode

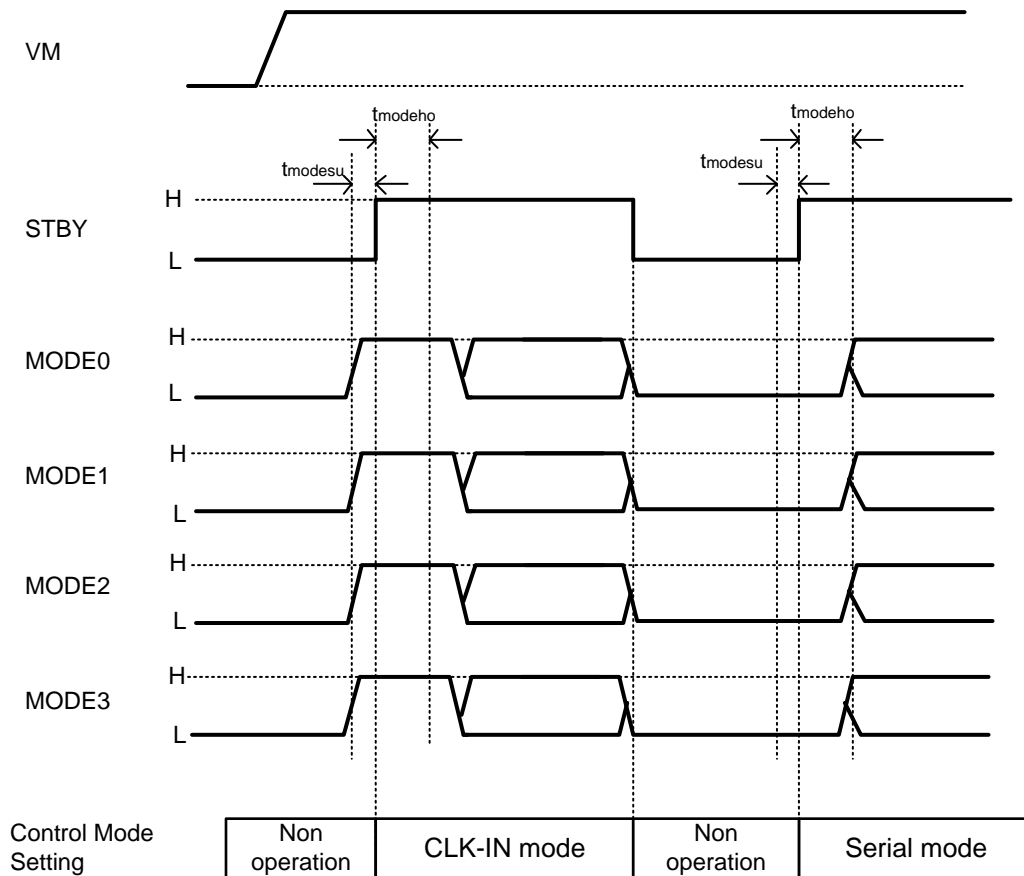

Figure 7. Control mode selection function

Table 7.2 Control Mode Selection Functions2

Characteristics	Symbol	Test condition	Min	Typ.	Max	Unit
Mode setting Setup time	t_{modesu}	To STBY edge	1	—	—	μs
Mode setting Data hold time	t_{modeho}	From STBY edge	100	—	—	μs

8. Functional Description 1 (for CLK-IN mode)

8.1. CLK Function

Each up-edge of the CLK signal will shift the motor's electrical angle per step.

Table 8.1 CLK Function

CLK pin input	Function
Up-edge	Shifts the electrical angle per step
Down-edge	(State of the electrical angle does not change)

8.2. ENABLE Function

The EN pin controls the ON and OFF of the stepping motor outputs. Motor operation starts and stops by setting H and L to the EN pin.

(When the EN pin is set to L (OFF), all of the MOSFETs turn off and become high impedance (hereafter, Hi-Z).)

Setting the EN pin to L, and avoiding the motor to operate during VM power-on and power-off (i.e., outside of the operating voltage range) is recommended. Then, switch the EN pin to H after the VM reaches the target voltage and becomes stable.

The EN pin should input High level through a resistor.

Table 8.2 ENABLE Function

EN pin input	Function
L	OFF (Hi-Z)
H	ON (Normal operation mode)

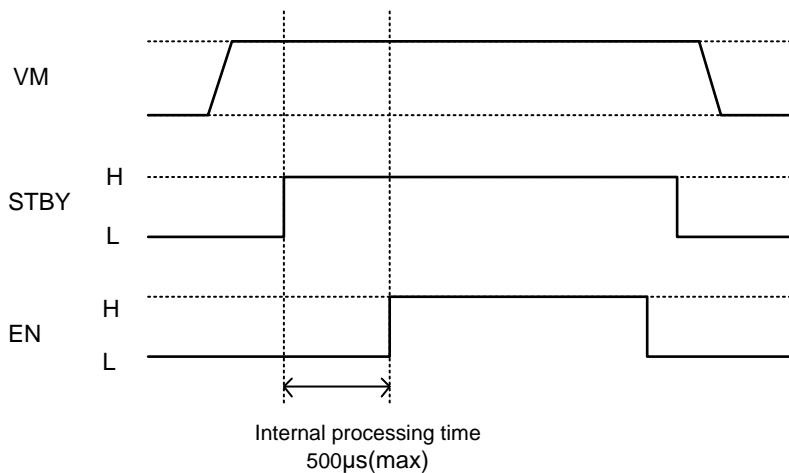

Figure 8.2 ENABLE Function

8.3. CW-CCW Function

CW-CCW pin controls the rotation direction of the motor.

Table 8.3 CW-CCW Function

CW-CCW pin input	Function
L	Counter clockwise operation (CCW)
H	Clockwise operation (CW)

8.4. Step Resolution Select Function

Step resolution is set up. TC78H670FTG has the two modes, Variable Mode and Fixed Mode. These modes are set up by the input state of MODE0-3 pins after releasing standby mode.

Variable Mode: Variable mode can be started with Full step resolution and changed step resolution during motor operating

Fixed Mode: Fixed mode can be started with the mode user selected and continued it during motor operating

Table 8.4.1 Step resolution selection functions

MODE3 pin input	MODE2 pin input	MODE1 pin input	MODE0 pin input	Mode	Function
L	L	L	H	Variable Mode	Full step resolution <-> 1/2 step resolution (2-phase excitation) (1-2-phase excitation)
L	L	H	L		Full step resolution <-> 1/4 step resolution (2-phase excitation) (W1-2-phase excitation)
L	L	H	H		Full step resolution <-> 1/8 step resolution (2-phase excitation) (2W1-2-phase excitation)
L	H	L	L		Full step resolution <-> 1/16 step resolution (2-phase excitation) (4W1-2-phase excitation)
L	H	L	H		Full step resolution <-> 1/32 step resolution (2-phase excitation) (8W1-2-phase excitation)
L	H	H	L		Full step resolution <-> 1/64 step resolution (2-phase excitation) (16W1-2-phase excitation)
L	H	H	H		Full step resolution <-> 1/128 step resolution (2-phase excitation) (32W1-2-phase excitation)
H	L	L	L		Fixed Mode
H	L	L	H	1/2 step resolution (1-2-phase excitation)	
H	L	H	L	1/4 step resolution (W1-2-phase excitation)	
H	L	H	H	1/8 step resolution (2W1-2-phase excitation)	
H	H	L	L	1/16 step resolution (4W1-2-phase excitation)	
H	H	L	H	1/32 step resolution (8W1-2-phase excitation)	
H	H	H	L	1/64 step resolution (16W1-2-phase excitation)	
H	H	H	H	1/128 step resolution (32W1-2-phase excitation)	

When Step mode is changed during operating, Step resolution can be set by SET_EN pin and UP-DW pin.
 Step mode is changed synchronously with Step Clock.

Table 8.4.2 SET_EN pin

SET_EN pin input	Function
L	Setting step mode is invalid
H	Setting step mode is available

Table 8.4.3 UP-DW Pin

UP-DW pin input	Function
L	Change step mode to high resolution
H	Change step mode to Low resolution

[Example: Full Step <-> 1/8 Step]

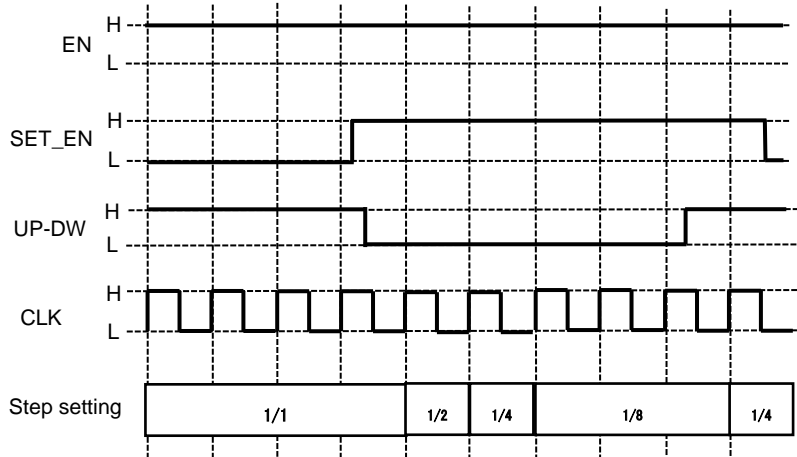

Figure 8.4 Full Step ⇔ 1/8 Step Setting

8.5. Timing Chart of Step Resolution Setting and Initial Angle

The arrow in the below figures indicates the timing of initial angle.

[Full step resolution]

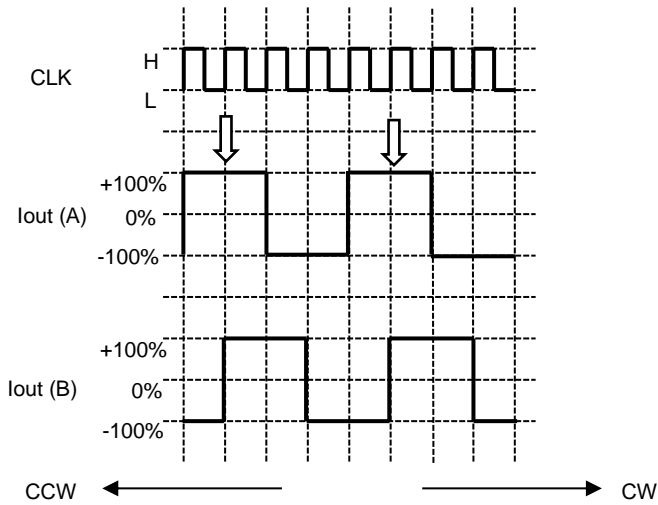

Figure 8.5.1 Full step resolution

[1/2 step resolution]

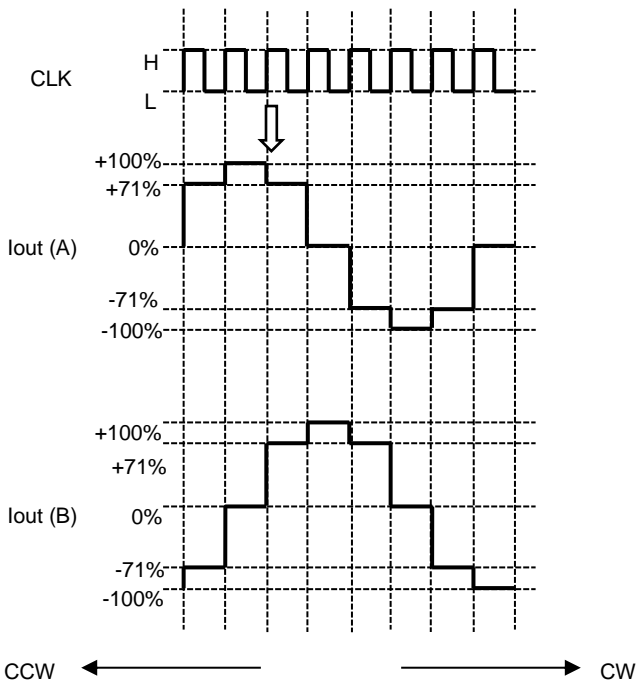

Figure 8.5.2 1/2 step resolution

Note: Timing charts may be simplified for explanatory purpose.

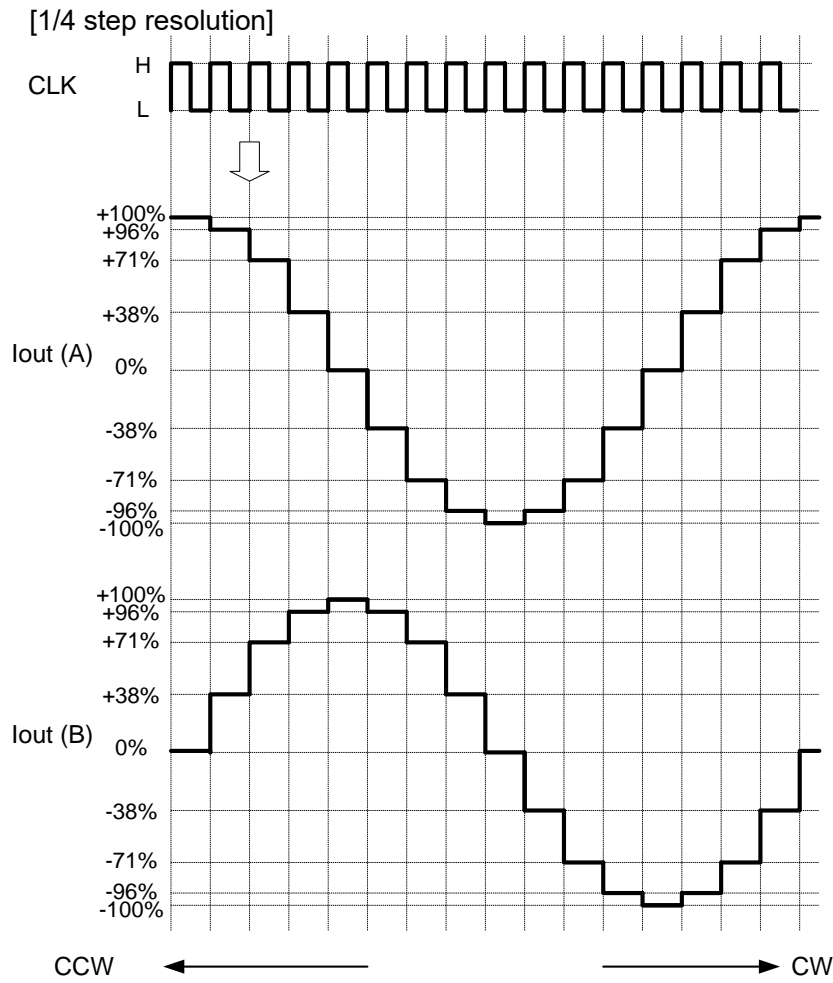

Figure 8.5.3 1/4 step resolution

Note: Timing charts may be simplified for explanatory purpose.

[1/8 step resolution]

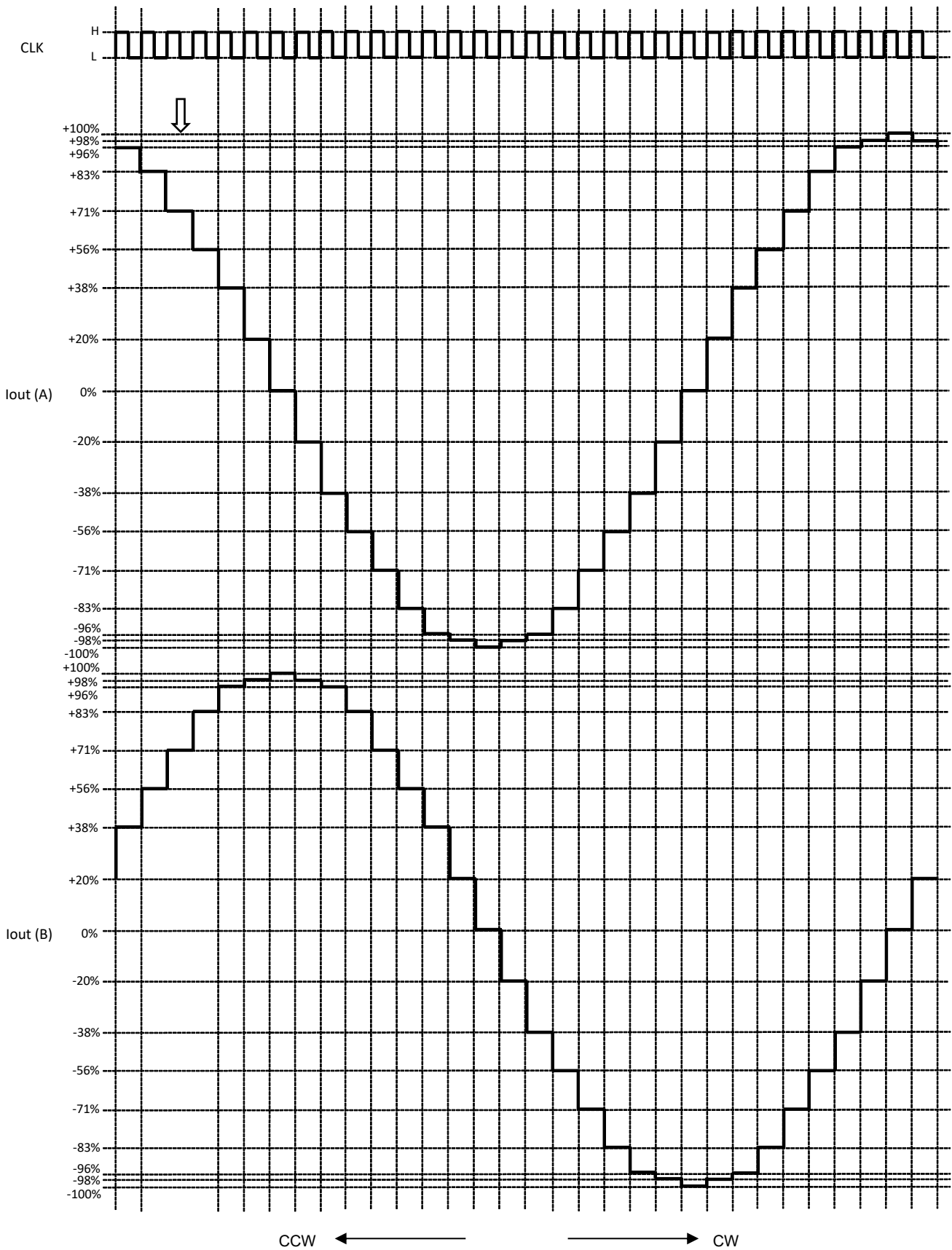

Figure 8.5.4 1/8 step resolution

Note: Timing charts may be simplified for explanatory purpose.

[1/16 step resolution]

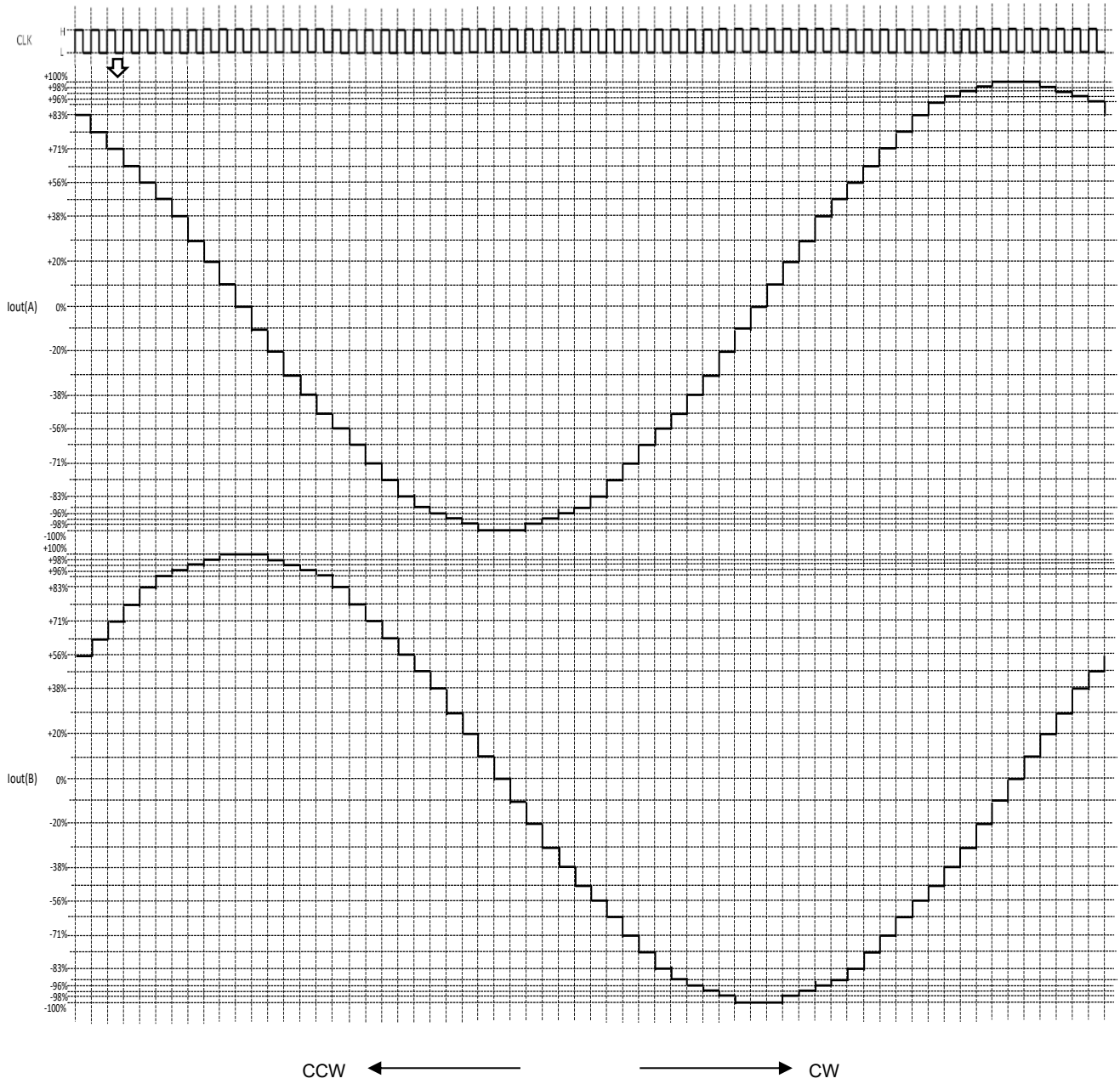

Figure 8.5.5 1/16 step resolution

Note: Timing charts may be simplified for explanatory purpose.

8.6. Step Setting and Current Percentage

Table 8.6 Step Setting and Current Percentage

Current (%)	1/1	1/2	1/4	1/8	1/16	1/32	1/64	1/128
100%	✓	✓	✓	✓	✓	✓	✓	✓
99%					✓	✓	✓	✓
98%				✓	✓	✓	✓	✓
97%					✓	✓	✓	✓
96%				✓	✓	✓	✓	✓
95%							✓	✓
94%						✓	✓	✓
93%							✓	✓
92%						✓	✓	✓
91%							✓	✓
90%					✓	✓	✓	✓
89%							✓	✓
88%						✓	✓	✓
87%							✓	✓
86%						✓	✓	✓
85%								✓
84%							✓	✓
83%				✓	✓	✓	✓	✓
82%							✓	✓
81%								✓
80%						✓	✓	✓
79%							✓	✓
78%								✓
77%					✓	✓	✓	✓
76%							✓	✓
75%								✓
74%						✓	✓	✓
73%								✓
72%							✓	✓
71%		✓	✓	✓	✓	✓	✓	✓
70%								✓
69%							✓	✓
68%								✓
67%						✓	✓	✓
66%								✓
65%							✓	✓
64%								✓
63%					✓	✓	✓	✓
62%							✓	✓
61%								✓
60%						✓	✓	✓
59%								✓
58%							✓	✓

Current (%)	1/1	1/2	1/4	1/8	1/16	1/32	1/64	1/128
57%								レ
56%				レ	レ	レ	レ	レ
55%								レ
53%							レ	レ
52%								レ
51%						レ	レ	レ
50%								レ
49%							レ	レ
48%								レ
47%					レ	レ	レ	レ
46%								レ
45%							レ	レ
44%								レ
43%						レ	レ	レ
42%								レ
41%							レ	レ
39%								レ
38%			レ	レ	レ	レ	レ	レ
37%								レ
36%							レ	レ
35%								レ
34%						レ	レ	レ
33%								レ
31%							レ	レ
30%								レ
29%					レ	レ	レ	レ
28%								レ
27%							レ	レ
25%						レ		レ
24%							レ	レ
23%								レ
22%							レ	レ
21%								レ
20%				レ	レ	レ	レ	レ
18%								レ
17%							レ	レ
16%								レ
15%						レ	レ	レ
13%								レ
12%							レ	レ
11%								レ
10%					レ	レ	レ	レ
9%								レ
7%							レ	レ
6%								レ

Current (%)	1/1	1/2	1/4	1/8	1/16	1/32	1/64	1/128
5%						レ	レ	レ
4%								レ
2%							レ	レ
1%								レ
0%		レ	レ	レ	レ	レ	レ	レ

8.7. Step Resolution and Set Current

Table 8.7 Step Resolution and Set Current

STEP	1/128		1/64		1/32		1/16		1/8		1/4		1/2		Full	
	Ach (%)	Bch (%)	Ach (%)	Bch (%)	Ach (%)	Bch (%)	Ach (%)	Bch (%)	Ach (%)	Bch (%)	Ach (%)	Bch (%)	Ach (%)	Bch (%)	Ach (%)	Bch (%)
00	100	0	100	0	100	0	100	0	100	0	100	0	100	0		
01	100	1														
02	100	2	100	2												
03	100	4														
04	100	5	100	5	100	5										
05	100	6														
06	100	7	100	7												
07	100	9														
08	100	10	100	10	100	10	100	10								
09	99	11														
010	99	12	99	12												
011	99	13														
012	99	15	99	15	99	15										
013	99	16														
014	99	17	99	17												
015	98	18														
016	98	20	98	20	98	20	98	20	98	20						
017	98	21														
018	98	22	98	22												
019	97	23														
020	97	24	97	24	97	24										
021	97	25														
022	96	27	96	27												
023	96	28														
024	96	29	96	29	96	29	96	29								
025	95	30														
026	95	31	95	31												
027	95	33														
028	94	34	94	34	94	34										
029	94	35														
030	93	36	93	36												
031	93	37														
032	92	38	92	38	92	38	92	38	92	38	92	38				
033	92	39														
034	91	41	91	41												
035	91	42														
036	90	43	90	43	90	43										
037	90	44														
038	89	45	89	45												
039	89	46														
040	88	47	88	47	88	47	88	47								

STEP	1/128		1/64		1/32		1/16		1/8		1/4		1/2		Full	
	Ach (%)	Bch (%)	Ach (%)	Bch (%)	Ach (%)	Bch (%)	Ach (%)	Bch (%)	Ach (%)	Bch (%)	Ach (%)	Bch (%)	Ach (%)	Bch (%)	Ach (%)	Bch (%)
041	88	48														
042	87	49	87	49												
043	86	50														
044	86	51	86	51	86	51										
045	85	52														
046	84	53	84	53												
047	84	55														
048	83	56	83	56	83	56	83	56	83	56						
049	82	57														
050	82	58	82	58												
051	81	59														
052	80	60	80	60	80	60										
053	80	61														
054	79	62	79	62												
055	78	62														
056	77	63	77	63	77	63	77	63								
057	77	64														
058	76	65	76	65												
059	75	66														
060	74	67	74	67	74	67										
061	73	68														
062	72	69	72	69												
063	72	70														
064	71	71	71	71	71	71	71	71	71	71	71	71	71	71	100	100
065	70	72														
066	69	72	69	72												
067	68	73														
068	67	74	67	74	67	74										
069	66	75														
070	65	76	65	76												
071	64	77														
072	63	77	63	77	63	77	63	77								
073	62	78														
074	62	79	62	79												
075	61	80														
076	60	80	60	80	60	80										
077	59	81														
078	58	82	58	82												
079	57	82														
080	56	83	56	83	56	83	56	83	56	83						
081	55	84														
082	53	84	53	84												
083	52	85														
084	51	86	51	86	51	86										

STEP	1/128		1/64		1/32		1/16		1/8		1/4		1/2		Full	
	Ach (%)	Bch (%)	Ach (%)	Bch (%)	Ach (%)	Bch (%)	Ach (%)	Bch (%)	Ach (%)	Bch (%)	Ach (%)	Bch (%)	Ach (%)	Bch (%)	Ach (%)	Bch (%)
085	50	86														
086	49	87	49	87												
087	48	88														
088	47	88	47	88	47	88	47	88								
089	46	89														
090	45	89	45	89												
091	44	90														
092	43	90	43	90	43	90										
093	42	91														
094	41	91	41	91												
095	39	92														
096	38	92	38	92	38	92	38	92	38	92	38	92				
097	37	93														
098	36	93	36	93												
099	35	94														
0100	34	94	34	94	34	94										
0101	33	95														
0102	31	95	31	95												
0103	30	95														
0104	29	96	29	96	29	96	29	96								
0105	28	96														
0106	27	96	27	96												
0107	25	97														
0108	24	97	24	97	24	97										
0109	23	97														
0110	22	98	22	98												
0111	21	98														
0112	20	98	20	98	20	98	20	98	20	98						
0113	18	98														
0114	17	99	17	99												
0115	16	99														
0116	15	99	15	99	15	99										
0117	13	99														
0118	12	99	12	99												
0119	11	99														
0120	10	100	10	100	10	100	10	100								
0121	9	100														
0122	7	100	7	100												
0123	6	100														
0124	5	100	5	100	5	100										
0125	4	100														
0126	2	100	2	100												
0127	1	100														
0128	0	100	0	100	0	100	0	100	0	100	0	100	0	100		

9. Functional Description 2 (for Serial mode)

Under the serial mode, it performs setting and motor control in the following 32-bit format.
 For the motor control, each current value is set in the serial setting, and the output is updated to the set current value at the timing of the LATCH signal.

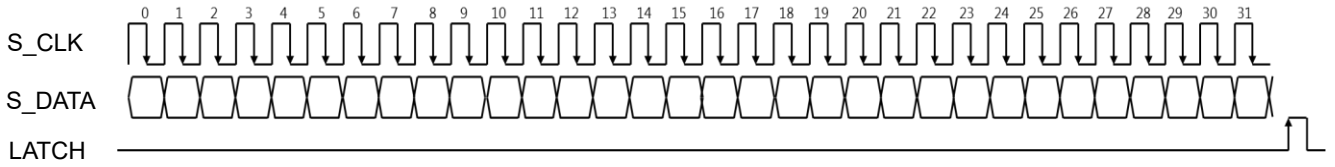

Figure 9 When the interface is in serial mode

Table 9 Serial Format Timing Settings

D0	D1	D2	D3	D4	D5	D6	D7	D8	D9	D10	D11	D12	D13	D14	D15
MDT_A0	MDT_A1	PHA	CA0	CA1	CA2	CA3	CA4	CA5	CA6	CA7	CA8	CA9	—	—	—
D16	D17	D18	D19	D20	D21	D22	D23	D24	D25	D26	D27	D28	D29	D30	D31
MDT_B0	MDT_B1	PHB	CB0	CB1	CB2	CB3	CB4	CB5	CB6	CB7	CB8	CB9	TRQ_0	TRQ_1	OPD

Note: Every issuing a command, the current setting transfers by one step.

9.1. Register

The registers to use the serial control are shown below.

9.1.1. PHx (x = A or B)

The polarity of the output current can be selected by PHx registers for each channel.

Table 9.1.1 PHx Function

PHx	Function
L	Setting the direction of the output current to minus * Default
H	Setting the direction of the output current to plus

9.1.2. Cx0 to Cx9 (x = A or B)

The output of each channel's DAC for current limitation can be set by Cx0 to Cx9 registers. The relation between Setting DAC and the output current (Iout) are shown below.

$$I_{out} (\text{Max}) = V_{ref} (\text{V}) \times \frac{C_{x[9:0]}}{1023} \times \text{Setting torque by the torque function} (\%)$$

9.1.3. TRQ0 and TRQ1

The value of the motor torque can be set by TRQ0 and TRQ1 registers.

Table 9.1.3 TRQ Function

TRQ1	TORQ0	Function
L	L	Torque setting: 100 % * Default
L	H	Torque setting: 75 %
H	L	Torque setting: 50 %
H	H	Torque setting: 25 %

9.1.4. OPD

An ON/OFF of the open detection function of motor output pins can be switched by OPD register.

Table 9.1.4 OPD Function

OPD	Function
L	Open detection OFF * Default
H	Open detection ON

9.1.5. Selectable Mixed Decay Function MDT_x0 and MDT_x1 (x = A or B)

The Selectable Mixed Decay can adjust the current regeneration amount during the period of current regeneration. Though the Mixed Decay is determined by controlling 2 different types of Decay (Fast Decay and Slow Decay), this function enables the user to select the ratio of the Mixed Decay using MDT_x0 and MDT_x1 register.

Table 9.1.5 Selectable Mixed Decay Function

MDT_x1	MDT_x0	Function
L	L	Fast Decay: 37.5 % (Fast Decay = OSCM × 6) * Default
L	H	Fast Decay: 75 %
H	L	Fast Decay: 50 %
H	H	Fast Decay only

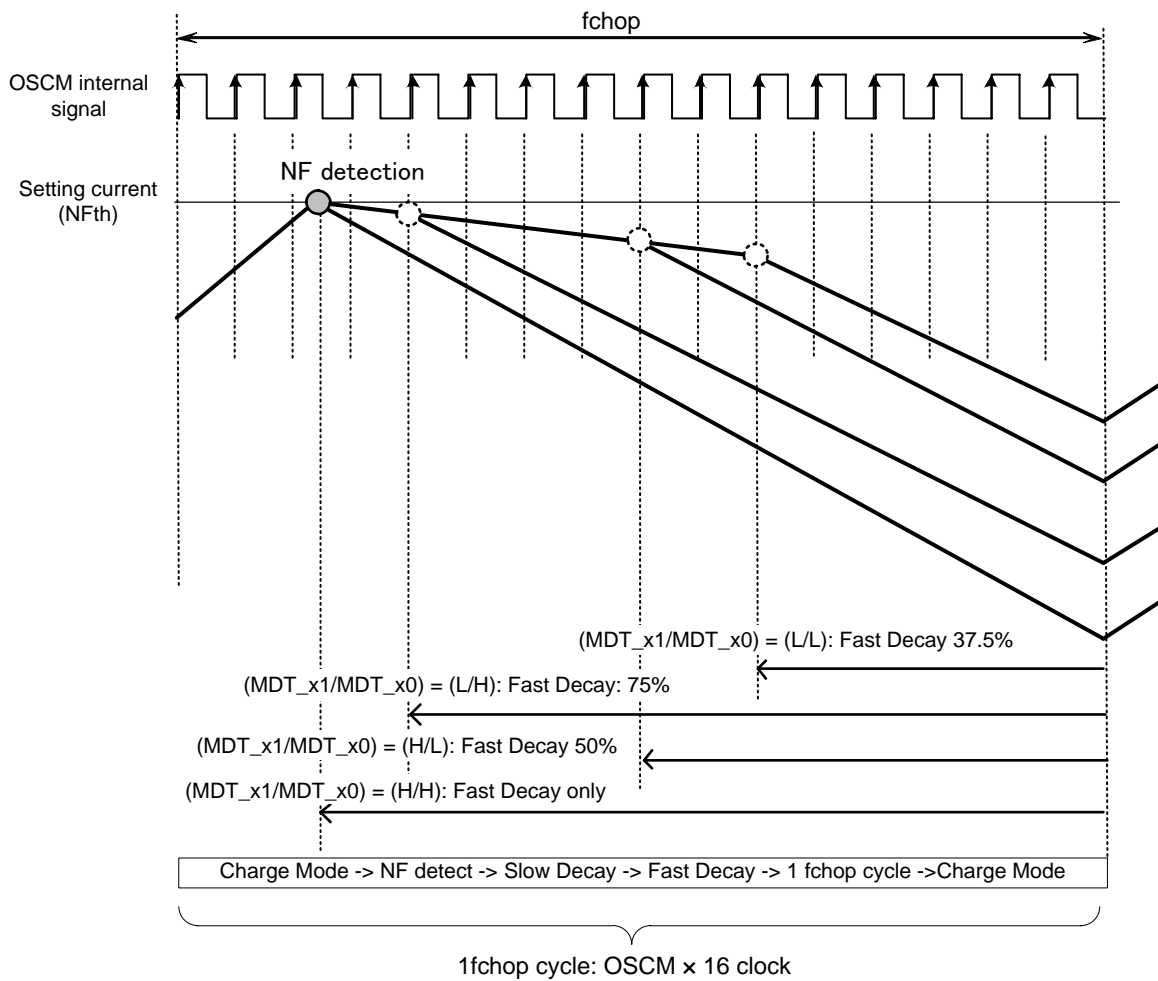

Figure 9.1.5 Selectable Mixed Decay Function

Note: x = A or B

Note: Decay control is controlled in order of Charge, Slow Decay and Fast Decay.

Note: The blanking time(AtBLK) is also set to prevent an incorrect operation in the NF detection (the motor current reaches the set current value (NFth)).

Note: Timing charts may be simplified for explanatory purpose.

9.1.5.1. Mixed Decay Waveform (Current Waveform) *Charge → Slow Decay → Fast Decay

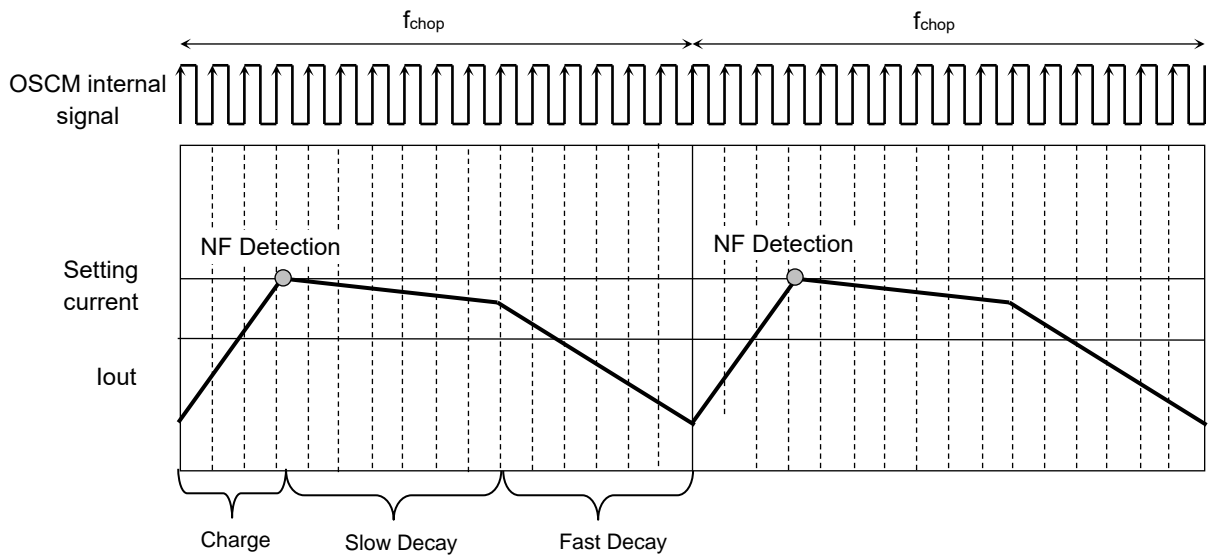

Figure 9.1.5.1 Mixed Decay Waveform (Current Waveform) *Charge → Slow Decay → Fast Decay

Note: Timing charts may be simplified for explanatory purpose.

9.1.5.2. Constant Current PWM Function and Timings *Charge → Slow Decay → Fast Decay

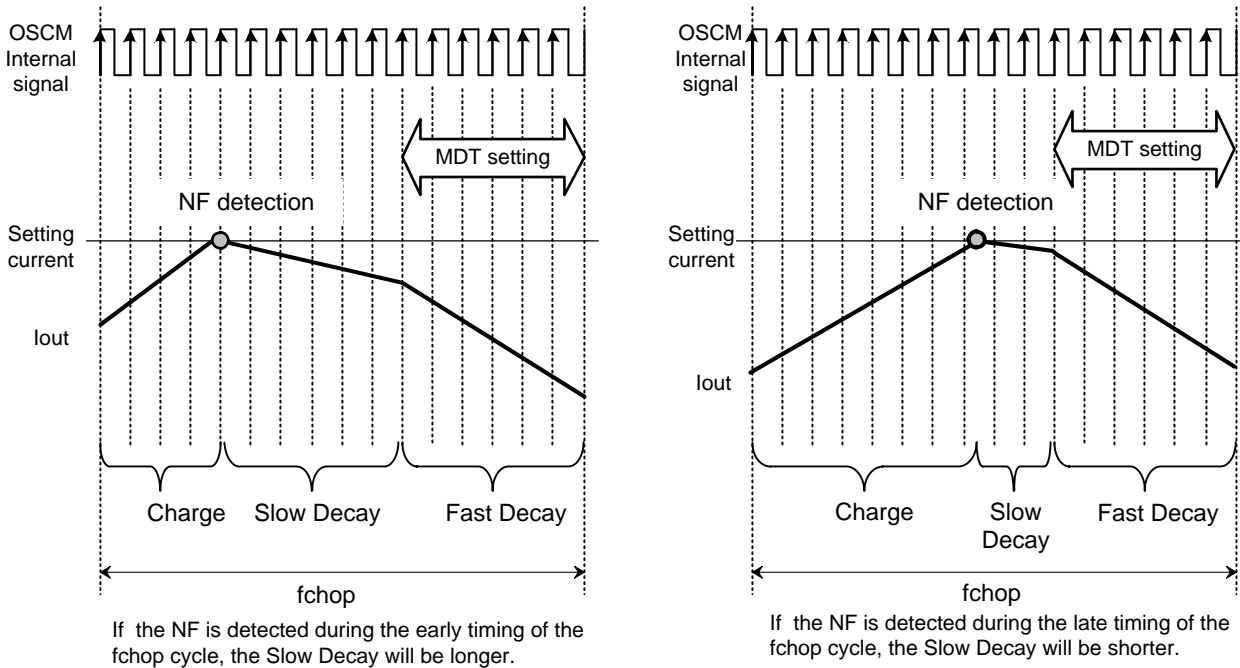

Figure 9.1.5.2.1 constant Current PWM Function and Timings *Charge → Slow Decay → Fast Decay

The Charge period (the time until the motor current reaches the set current value) is determined by the operating status.

Therefore the NF detection timing (the motor current reaches the set current value) with the chopping cycle (fchop) may change. If NF is detected in the early period of the fchop cycle, the Slow Decay will be longer. If NF is detected in the late period of the fchop cycle, the Slow Decay will be shorter, as shown above.

Note: The chopping cycle is determined as: $fchop - (Charge + Fast Decay) = Slow Decay$
 (Fast Decay ratio can be changed by MDT_x0 and MDT_x1 (x = A or B) registers setting.)

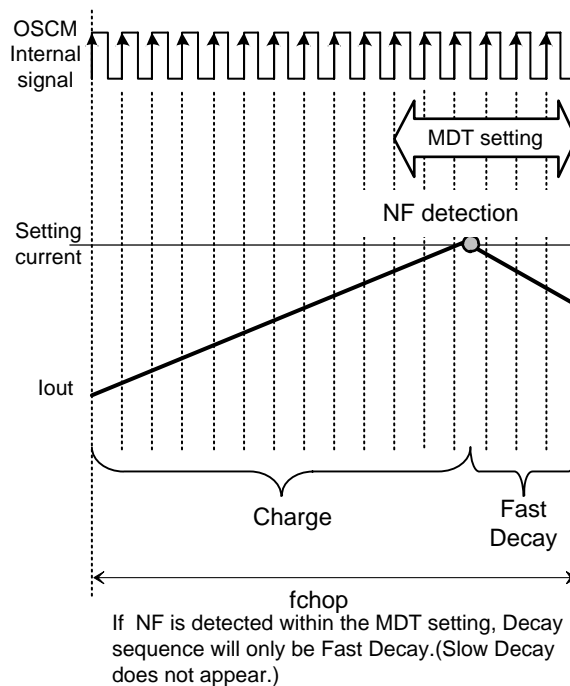

Figure 9.1.5.2.2 If the NF detection was within the timing set by the MDT register

Note: Timing charts may be simplified for explanatory purpose.

9.1.5.3. Mixed Decay current waveform *Charge → Slow Decay → Fast Decay

- When the next current step is higher:

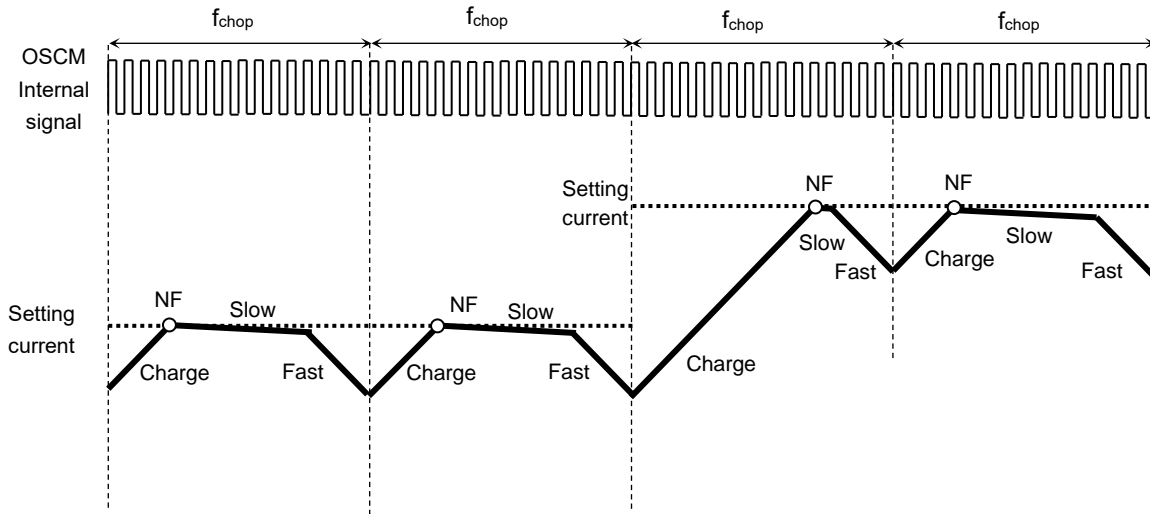

Figure 9.1.5.3.1 When the next current step is higher

- When Charge Period is More Than 1 f_{chop} Cycle:

When the Charge period is longer than f_{chop} cycle, the Charge period extends until the motor current reaches the NF threshold. Once the current reaches the next current step, then the sequence goes on to Decay mode.

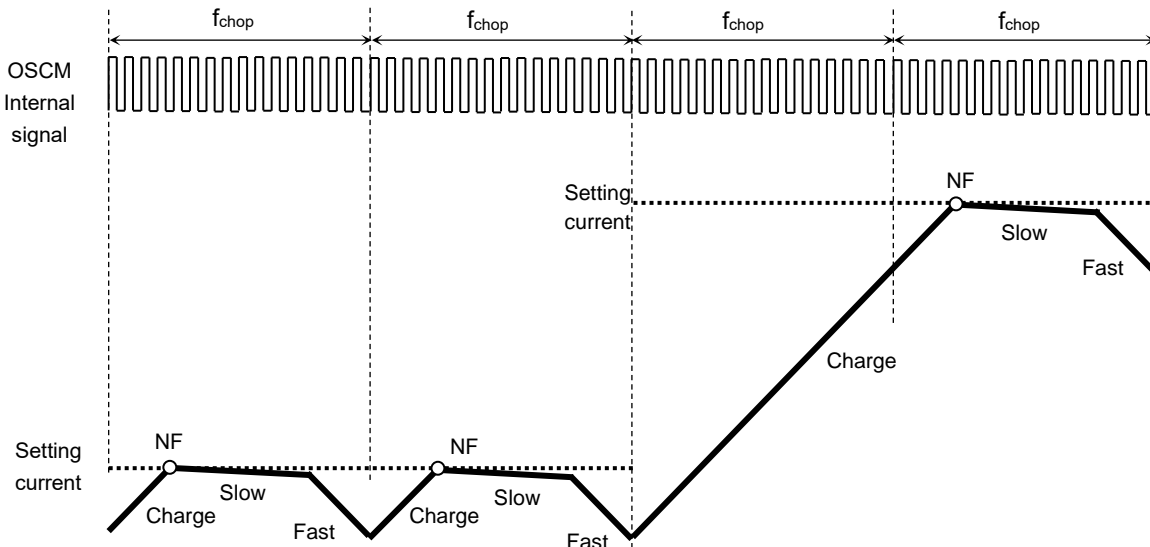

Figure 9.1.5.3.2 When Charge Period is More Than 1 f_{chop} Cycle

- When the Next Current Step is lower:

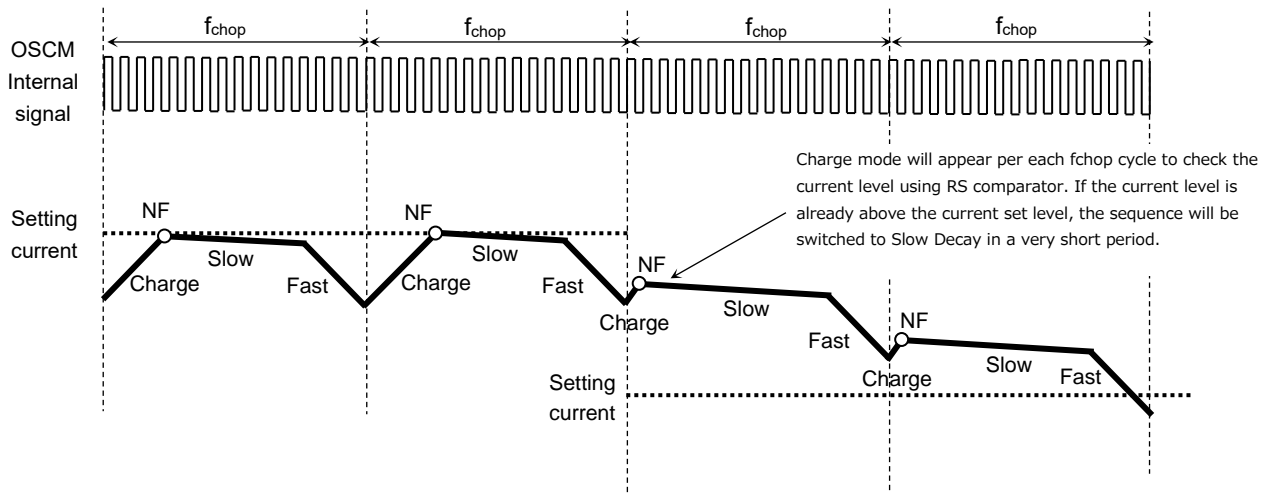

Figure 9.1.5.3.3 When the Next Current Step is lower

Note: Timing charts may be simplified for explanatory purpose.

9.2. Serial Setting Example when driving a motor

Serial setting example for motor operation is shown below.

The motor operates with full step resolution by transmitting from the 1st to 4th commands repeatedly.

Table 9.2 Serial Setting Example when driving a motor

1st Command

D0	D1	D2	D3	D4	D5	D6	D7	D8	D9	D10	D11	D12	D13	D14	D15
0	0	1	1	1	1	1	1	1	1	1	1	1	0	0	0

D16	D17	D18	D19	D20	D21	D22	D23	D24	D25	D26	D27	D28	D29	D30	D31
0	0	1	1	1	1	1	1	1	1	1	1	1	0	0	0

2nd Command

D0	D1	D2	D3	D4	D5	D6	D7	D8	D9	D10	D11	D12	D13	D14	D15
0	0	0	1	1	1	1	1	1	1	1	1	1	0	0	0

D16	D17	D18	D19	D20	D21	D22	D23	D24	D25	D26	D27	D28	D29	D30	D31
0	0	1	1	1	1	1	1	1	1	1	1	1	0	0	0

3rd Command

D0	D1	D2	D3	D4	D5	D6	D7	D8	D9	D10	D11	D12	D13	D14	D15
0	0	0	1	1	1	1	1	1	1	1	1	1	0	0	0

D16	D17	D18	D19	D20	D21	D22	D23	D24	D25	D26	D27	D28	D29	D30	D31
0	0	0	1	1	1	1	1	1	1	1	1	1	0	0	0

4th Command

D0	D1	D2	D3	D4	D5	D6	D7	D8	D9	D10	D11	D12	D13	D14	D15
0	0	1	1	1	1	1	1	1	1	1	1	1	0	0	0

D16	D17	D18	D19	D20	D21	D22	D23	D24	D25	D26	D27	D28	D29	D30	D31
0	0	0	1	1	1	1	1	1	1	1	1	1	0	0	0

10. Common Function (CLK-IN Mode and Serial Mode)

10.1. Error Function (Error detect flag output)

When TC78H670FTG detects some errors, ERR pin outputs low level to peripheral block. Since ERR pin and EN pin share the function, the below peripheral circuit between TC78H670FTG and HOST MCU should be inserted. EN pin should input High level through a resistor. In normal status, since the internal MOSFET is OFF, the level of ERR pin is equal to the EN control voltage from outside. When the error function (Thermal shutdown (TSD), Over current (ISD), or motor load open (OPD)) occurs, ERR pin will become Low (the internal MOSFET is ON). When the error detection is released by reasserting the VM power supply or setting the device to STANDBY mode, ERR pins show “normal status”.

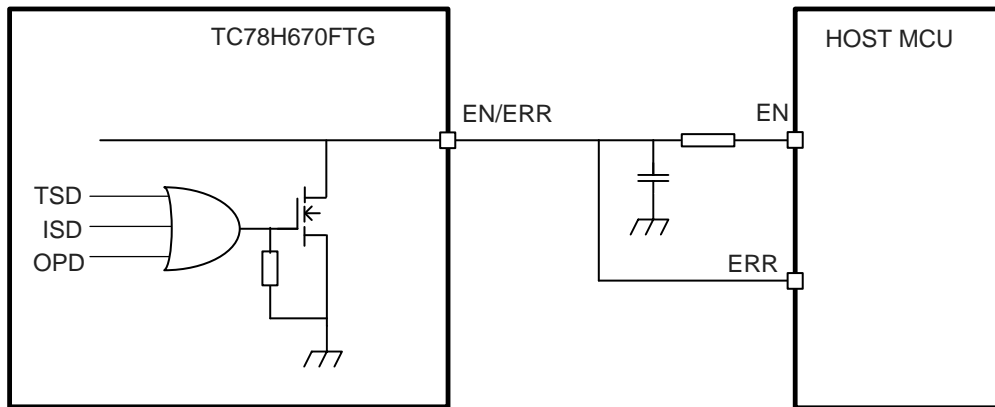

Figure 10.1 Error Function (Error detect flag output)

Note: This figure may be simplified for explanatory purpose.

Note: It is possible to detect OPD only when Serial mode is selected.

Table 10.1 ERR Function

ERR pin output	Function
H (Pull-up)	Normal status (Normal operation)
L	Detect error status (ISD, TSD, OPD)

After detecting TSD detection: TC78H670FTG draws out currents of motor by Fast mode. If the output current is zero-detected or for 1ms at maximum, the output becomes Hi-Z.

After detecting ISD detection: In H Bridge high-side (Pch DMOS) detection, TC78H670FTG draws out currents of motor by Slow mode on low-side. The output after 80 ms (typ.) becomes Hi-Z. In H Bridge low-side (Nch DMOS) detection, it draws out by Slow mode on high-side.

Note: Above times are reference values, and are not guaranteed.

10.2. STANDBY Function

It is possible to switch to Standby mode by STBY pin.

Table 10.2 STANDBY FUNCTION

STBY pin input	Function	MEMO
L	Standby mode	Electrical angle: 45°
H	Normal operation	—

Note: When STBY pin is Low, TC78H670FTG stops supplying the power to logic circuit. Therefore, Logic circuit is reset and Electrical angle and Step mode are initialized.

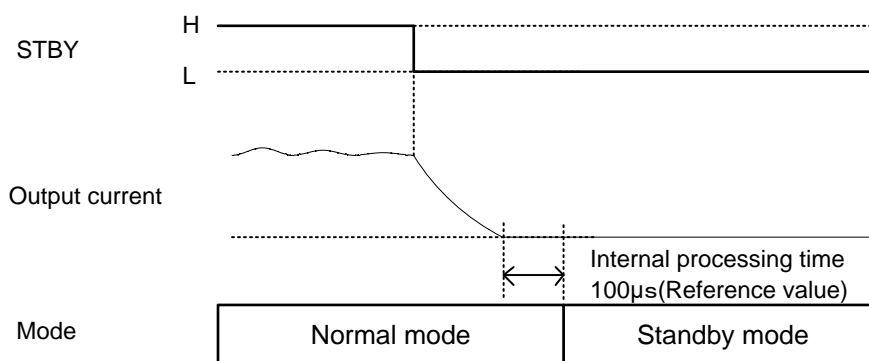

Figure 10.2 STANDBY FUNCTION

If the output current is zero-detected, the operation mode enters into the standby mode after 100 µs.

The mode enters into the standby mode forcedly after 1 ms(max) from STBY=L.

Note: Above times are reference values, and are not guaranteed.

11. Output Transistor Function Mode

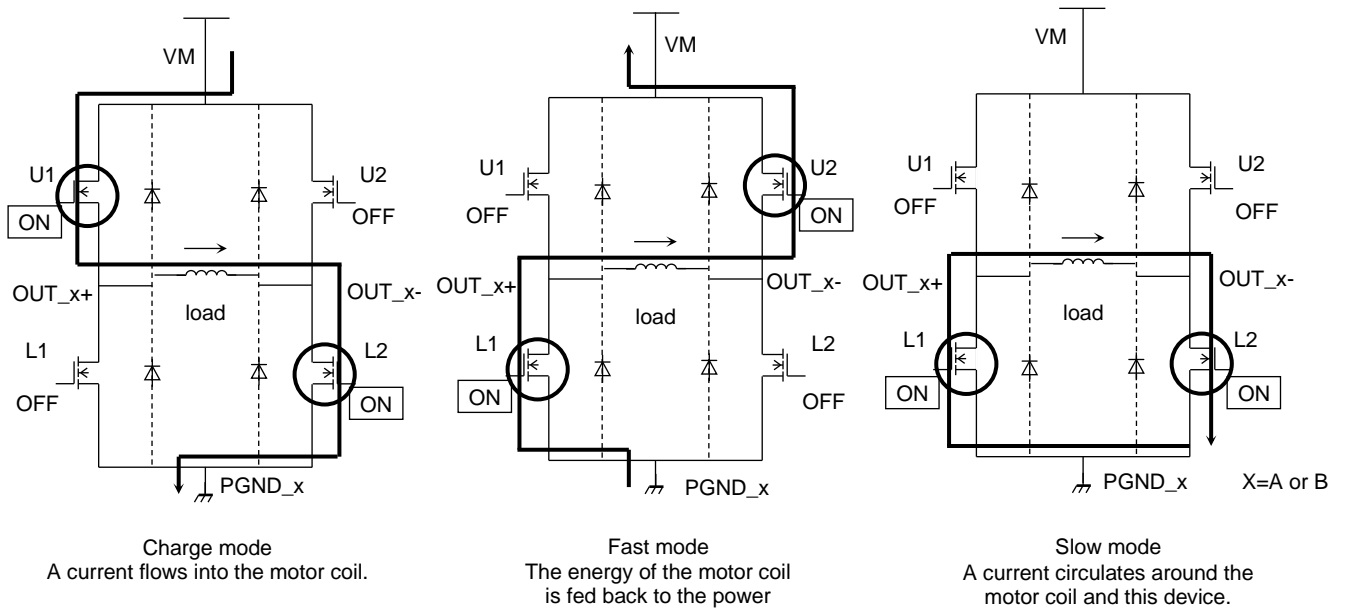

Figure 11 Output Transistor Function Mode

Note: The equivalent circuit diagrams may be simplified or some parts of them may be omitted for explanatory purposes.

11.1. Output Transistor Function

Table 11.1.1 Output Transistor Function1

MODE	U1	U2	L1	L2
Charge	ON	OFF	OFF	ON
Slow	OFF	OFF	ON	ON
Fast	OFF	ON	ON	OFF

Note: This table shows an example of when the current flows as indicated by the arrows in the figures shown above. If the current flows in the opposite direction, refer to the following table.

Table 11.1.2 Output Transistor Function2

MODE	U1	U2	L1	L2
Charge	OFF	ON	ON	OFF
Slow	OFF	OFF	ON	ON
Fast	ON	OFF	OFF	ON

This IC controls the motor current to be constant by changing 3 modes listed above automatically

Note: To eliminate shoot-through current that flows from supply to ground due to the simultaneous conduction of high side and low side transistors in the bridge output, a dead time (100ns (Reference value)) is generated in this IC when transistors switch from on to off, or vice versa.

12. Calculation of the Predefined Output Current

The peak output current (Setting current value) can be set via the reference voltage (V_{ref}), as follows:

$$I_{out} (Max) = 1.1 \times V_{ref} (V)$$

13. OSCM Oscillation Frequency and Chopping Frequency

The OSCM oscillation frequency (f_{OSCM}) and chopping frequency (f_{chop}) can be adjusted by the external resistor (R_{OSC}) connecting to OSCM pin.

Table 13 OSCM Oscillation Frequency and Chopping Frequency

$R_{OSC}[k\Omega]$	$f_{OSCM} [kHz](typ.)$	$f_{chop}[kHz](typ.)$
18	3290	206
22	2691	168
30	1982	124
39	1526	95
47	1266	79
56	1064	66
75	795	50
91	656	41

If chopping frequency is raised, ripple of current will become small and wave-like reproducibility will improve.

However, the gate loss inside IC goes up and generation of heat becomes large.

By lowering chopping frequency, reduction in generation of heat is expectable. However, ripple of current may become large.

It is a standard about 70 kHz. A setup in the range of 50 kHz to 100 kHz is recommended.

14. Absolute Maximum Ratings ($T_a = 25\text{ }^\circ\text{C}$)

Table 14 Absolute Maximum Ratings ($T_a = 25\text{ }^\circ\text{C}$)

Characteristics	Symbol	Rating	Unit	Remarks
Motor output voltage	V_{out}	20	V	Outputs are OFF
		18	V	Outputs are ON
Motor power supply (non-active)	V_M	20	V	STBY pin = L
Motor power supply (active)		-0.4 to 18	V	STBY pin = H
Motor output current	I_{out}	2.0	A	(Note 1)
Logic input voltage	$V_{IN(H)}$	6.0	V	—
	$V_{IN(L)}$	-0.4	V	—
ERR output pin voltage	V_{LO}	6.0	V	—
ERR output pin inflow current	I_{LO}	6.0	mA	—
Power dissipation	P_D	1.79	W	(Note 2)
Operating temperature	T_{opr}	-40 to 85	$^\circ\text{C}$	—
Storage temperature	T_{stg}	-55 to 150	$^\circ\text{C}$	—
Junction temperature	$T_{j(max)}$	150	$^\circ\text{C}$	—

Note1: Usually, the maximum current value at the time should use 70 % or less of the absolute maximum ratings for a standard on thermal rating. The maximum output current may be further limited in view of thermal considerations, depending on ambient temperature and board conditions.

Note2: When mounted on the board (JEDEC 4 layers) ($T_a = 25\text{ }^\circ\text{C}$)

When T_a exceeds $25\text{ }^\circ\text{C}$, it is necessary to do the derating with $14.3\text{ mW}/^\circ\text{C}$.

T_a : Ambient temperature

T_{opr} : Ambient temperature while the IC is active

T_j : Junction temperature while the IC is active.

The maximum junction temperature is limited by the thermal shutdown (TSD) circuitry. It is advisable to keep the maximum current below a certain level so that the maximum junction temperature, T_j (MAX), will not exceed $120\text{ }^\circ\text{C}$.

Caution) Absolute maximum ratings

The absolute maximum ratings of a semiconductor device are a set of ratings that must not be exceeded, even for a moment. Do not exceed any of these ratings. Exceeding the rating (s) may cause device breakdown, damage or deterioration, and may result in injury by explosion or combustion.

The value of even one parameter of the absolute maximum ratings should not be exceeded under any circumstances. The TC78H670FTG does not have overvoltage detection circuit. Therefore, the device is damaged if a voltage exceeding its rated maximum is applied.

All voltage ratings, including supply voltages, must always be followed. The other notes and considerations described later should also be referred to.

15. Operating Range (Ta = -40 to 85 °C)

Table 15 Operating Range (Ta = -40 to 85 °C)

Characteristics	Symbol	Min	Typ.	Max	Unit	Remarks
Motor power supply	V _M	2.5	-	16.0	V	-
Motor output current	I _{out}	-	1.1	2.0	A	(Note 1)
ERR pin output voltage	V _{LO}	-	-	5.5	V	-
Vref reference voltage	V _{ref}	0	-	1.8	V	-

Note1: Maximum current for actual usage may be limited by the operating circumstances such as operating conditions (exciting mode, operating time, and so on), ambient temperature, and heat conditions (board condition and so on).

16. Electrical Specifications 1

(T_a = 25°C, V_M = 2.5 to 16 V unless otherwise specified)

Table 16 Electrical Specifications 1

Characteristics		Symbol	Test condition	Min	Typ.	Max	Unit
Logic input voltage	HIGH	V _{IN(H)}	Logic input (Note1)	1.5	—	5.5	V
	LOW	V _{IN(L)}	Logic input (Note1)	0	—	0.7	V
Logic input hysteresis voltage		V _{IN(HYS)}	Logic input (Note1)	—	60	—	mV
Logic input current	HIGH	I _{IN(H)}	V _{IN(H)} = 3.3 V	—	33	45	μA
	LOW	I _{IN(L)}	V _{IN(L)} = 0 V	—	—	1	μA
ERR pin output voltage	LOW	V _{OL(LO)}	I _{OL} = 5 mA, output = L	—	—	0.5	V
Current consumption		I _{M1}	Output pins = open Standby mode	—	—	0.1	μA
		I _{M2}	Output pins = open EN pin = L in releasing Standby mode	—	2.8	3.5	mA
		I _{M3}	Output pins = open Full step resolution fCLK=75 kHz	—	3.3	4.3	mA
Output leakage current	High-side	I _{OH}	V _M = 18 V, V _{out} = 0 V	—	—	1	μA
	Low-side	I _{OL}	V _M = V _{out} = 18 V	-1	—	—	μA
Motor current channel differential		ΔI _{out1}	Current differential between Ch	-5	0	5	%
Motor current setting accuracy		ΔI _{out2}	I _{out} = 1.1 A	-5	0	5	%
Motor output ON resistance (High side + Low side)		R _{on(H+L)}	T _j = 25 °C, V _M = 12 V, I _{out} = 1 A	—	0.48	0.6	Ω

Note: When the logic signal is applied to the device whilst the V_M power supply is not asserted; the device is designed not to function, but for safe usage, please apply the logic signal after the V_M power supply is asserted and the V_M voltage reaches the proper operating range.

Note1: V_{IN(H)} is defined as the V_{IN} voltage that causes the outputs (OUT_A+ pin, OUT_A- pin, OUT_B+ pin, OUT_B- pin) to change when a pin under test is gradually raised from 0 V. V_{IN(L)} is defined as the V_{IN} voltage that causes the outputs (OUT_A+ pin, OUT_A- pin, OUT_B+ pin, OUT_B- pin) to change when the pin is then gradually lowered from 5V. The difference between V_{IN(H)} and V_{IN(L)} is defined as the V_{IN(HYS)}.

17. Electrical Specifications 2

($T_a = 25\text{ }^\circ\text{C}$, $V_M = 2.5\text{ to }16\text{ V}$ unless otherwise specified)

Table 17 Electrical Specifications 2

Characteristics	Symbol	Test condition	Min	Typ.	Max	Unit
Vref input current	I_{ref}	$V_{ref} = 1.8\text{ V}$	—	0	1	μA
Thermal shutdown (TSD) threshold (Note1)	T_{JTSD}	—	145	165	175	$^\circ\text{C}$
UVLO release voltage (Note 2)	V_{UVLO}	At rising V_M	2.1	2.3	—	V
UVLO hysteresis voltage	V_{hys_uvlo}	—	—	200	—	mV
Over current detection (ISD) threshold (Note3)	I_{SD}	$V_M = 12\text{ V}$	2.5	3.2	4.2	A

Note1: Thermal shutdown (TSD)

When the junction temperature of the device reaches the TSD threshold, the TSD circuit is triggered; the internal reset circuit then turns off the output transistors. Once the TSD circuit is triggered, the device will set output pin to Hi-Z, and can be cleared by reasserting the V_M power source, or setting the STBY pins to standby mode. The TSD circuit is a backup function to detect a thermal error, therefore is not recommended to be used aggressively.

Note 2: Under voltage lockout (UVLO)

When the supply voltage to V_M pin is 2.1 V or less (typ.), the internal circuit is triggered; the internal reset circuit then turns off the output transistors. Once the UVLO is triggered, it can be cleared by reasserting the V_M supply voltage to 2.3 V or more (typ.)

Note3: Over current detection (ISD)

When the output current reaches the threshold, the ISD circuit is triggered; the internal reset circuit then turns off the output transistors. It has a dead band time of 1.2 μs (typ.) to avoid ISD false triggering by switching noise. Once the ISD circuit is triggered, the device will set output pins to Hi-Z, and can be cleared by reasserting the V_M power source, or setting the STBY pin to standby mode.

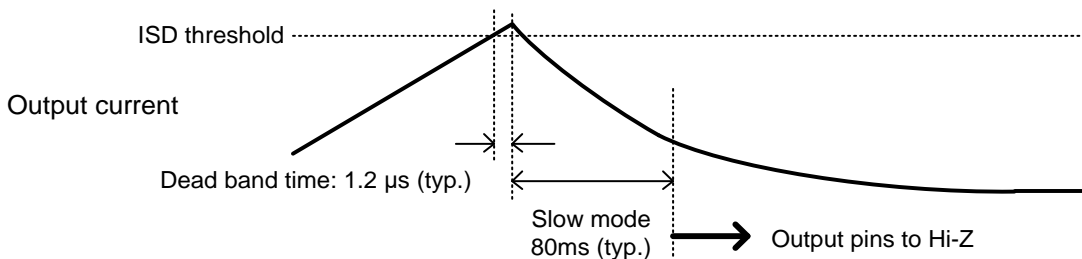
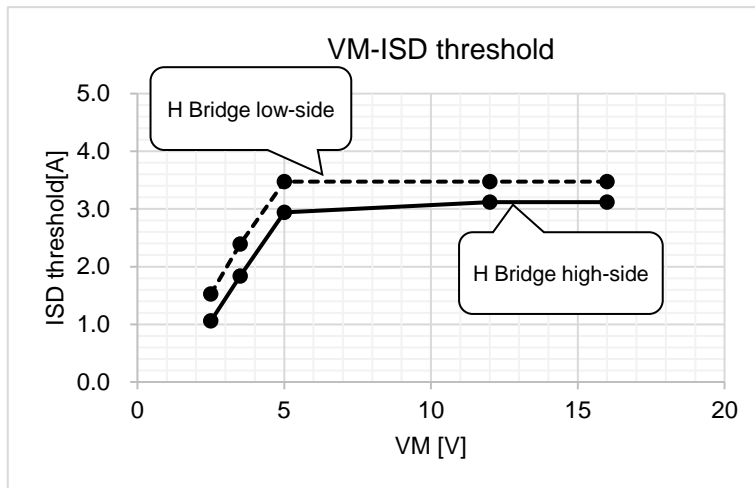

Figure 17 VM-ISD threshold

Note: Above ISD operation threshold value and band times are reference values, and are not guaranteed.

Back-EMF

While a motor is rotating, there is a timing at which power is fed back to the power supply. At that timing, the motor current recirculates back to the power supply due to the effect of the motor back-EMF.

If the power supply does not have enough sink capability, the power supply and output pins of the device might rise above the rated voltages. The magnitude of the motor back-EMF varies with usage conditions and motor characteristics. It must be fully verified that there is no risk that the TC78H670FTG or other components will be damaged or fail due to the motor back-EMF.

Cautions on Overcurrent Shutdown (ISD) and Thermal Shutdown (TSD)

The ISD and TSD circuits are only intended to provide temporary protection against irregular conditions such as an output short-circuit; they do not necessarily guarantee the complete IC safety. If the device is used beyond the specified operating ranges, these circuits may not operate properly: then the device may be damaged due to an output short-circuit.

The ISD circuit is only intended to provide a temporary protection against an output short-circuit. If such a condition persists for a long time, the device may be damaged due to overstress.

Overcurrent conditions must be removed immediately by external hardware.

IC Mounting

Do not insert devices incorrectly or in the wrong orientation. Otherwise, it may cause breakdown, damage and/or deterioration of the device.

18. AC Electrical Specification 1

($T_a = 25\text{ }^\circ\text{C}$, $V_M = 12\text{ V}$, $6.8\text{ mH}/5.7\text{ }\Omega$ unless otherwise specified)

Table 18 AC Electrical Specification 1

Characteristics	Symbol	Test condition	Min	Typ.	Max	Unit
CLK input frequency	f_{CLK}	—	—	—	400	kHz
Inside filter of CLK input minimum High width	$t_{CLK(H)}$	The CLK(H) minimum pulse width	500	—	—	ns
Inside filter of CLK input minimum Low width	$t_{CLK(L)}$	The CLK(L) minimum pulse width	500	—	—	ns
Output transistor switching specific	t_r	—	10	20	30	ns
	t_f	—	10	20	30	ns
	$t_{pLH(CLK)}$	—	—	840	—	ns
	$t_{pHL(CLK)}$	—	—	900	—	ns
Analog noise blanking time	A_{IBLK}	$V_M = 12\text{ V}$	340	540	740	ns
Oscillator frequency accuracy	Δf_{OSCM}	ROSC = 47 k Ω $V_M = 2.5\text{ V to }16\text{ V}$	-15	—	+15	%
Oscillator reference frequency	f_{OSCM}	ROSC = 47 k Ω	1076	1266	1456	kHz
Chopping frequency	f_{chop}	Output: Active, $f_{OSCM} = 1266\text{ kHz}$	—	79	—	kHz

AC Electrical Specification Timing chart

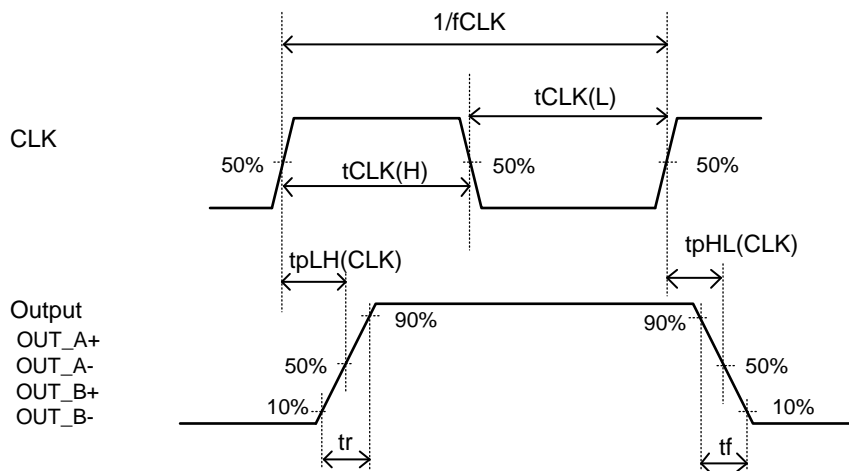

Figure 17 AC Electrical Specification Timing chart

Note: Timing charts may be simplified for explanatory purpose.

19. AC Electrical Specification 2

($T_a = 25\text{ }^\circ\text{C}$, $V_M = 2.5$ to 16 V unless otherwise specified)

Table 19 AC Electrical Specification 2

Characteristics	Symbol	Test condition	Min	Typ.	Max	Unit	No.in Timing Chart
Serial CLK frequency	f_{SCLK}	$V_{IN} = 3.3\text{ V}$	1.0	—	25	MHz	—
CLK cycle	t_{SCKW}	$V_{IH} = 3.3\text{ V}$, $V_{IL} = 0\text{ V}$, $t_r = t_f = 23\text{ ns}$	46	—	—	ns	—
Minimum CLK pulse width	$t_{w(CLK)}$	$V_{IN} = 3.3\text{ V}$	40	—	—	ns	1
	$t_{wp(CLK)}$		20	—	—	ns	2
	$t_{wn(CLK)}$		20	—	—	ns	3
Minimum LATCH pulse width	$t_{LATCH(H)}$	$V_{IN} = 3.3\text{ V}$	20	—	—	ns	4
Data setup time	$t_{suSIN-CLK}$	$V_{IN} = 3.3\text{ V}$	10	—	—	ns	5
	$t_{suLT-CLK}$		10	—	—	ns	6
Data hold time	$t_{hSIN-CLK}$	$V_{IN} = 3.3\text{ V}$	10	—	—	ns	7
	$t_{hLT-CLK}$		40	—	—	ns	8
LATCH cycle	t_{cLT}	$V_{IN} = 3.3\text{ V}$	1.32	—	—	μs	9

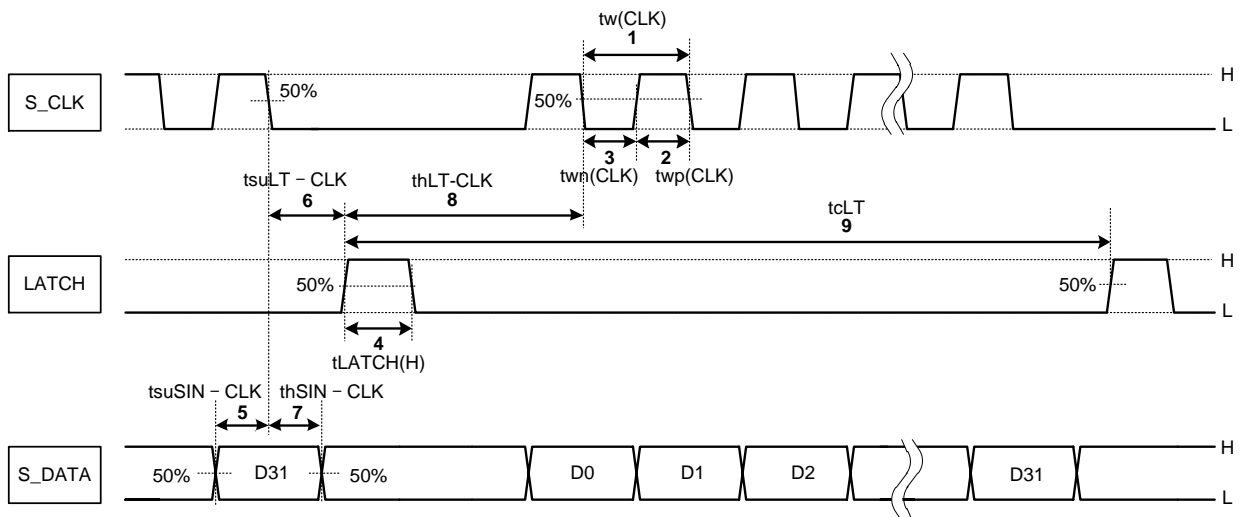
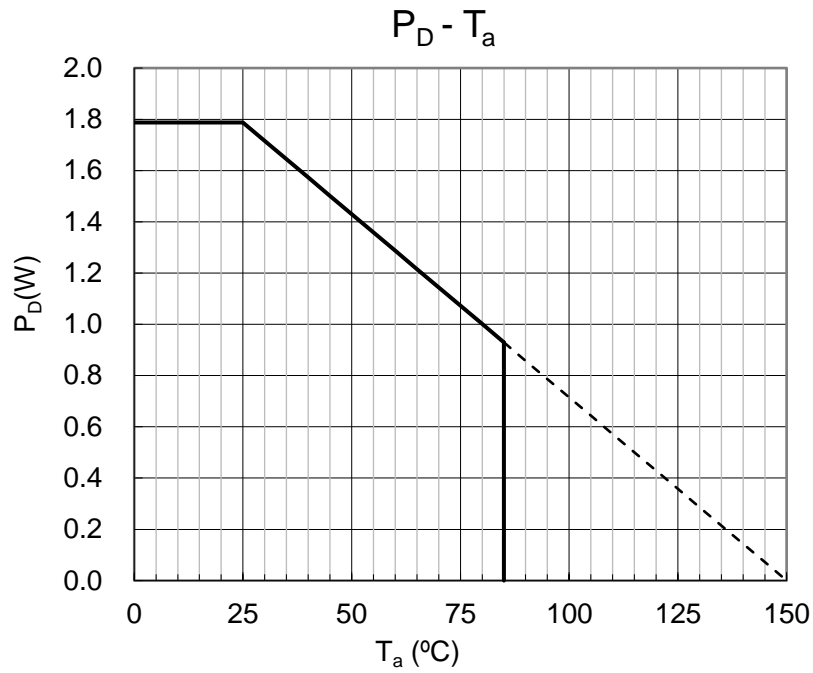

Figure 19 AC Electrical Specification 2

20. P_D-T_a Characteristics (for reference only)



When mounted on the board (JEDEC 4 layers)

Figure 20 P_D-T_a Characteristics(Note)

Note: Characteristics shown above are reference values and not guaranteed.

21. Application Circuit Example

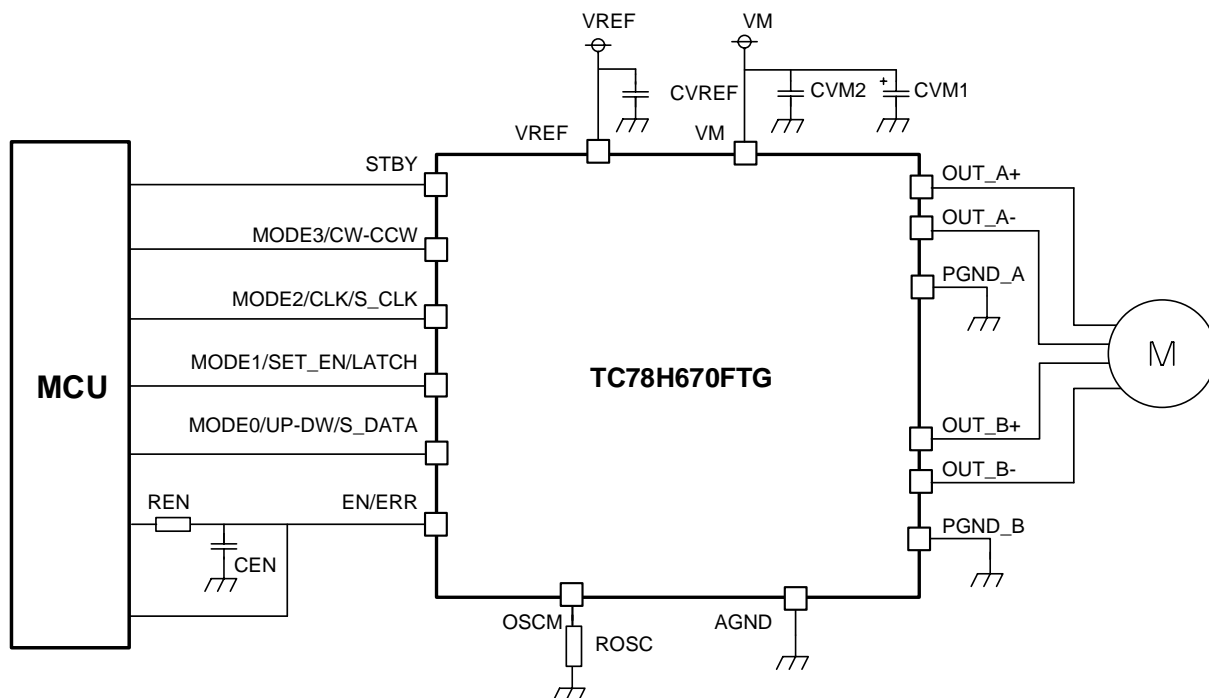

Figure 21 Application Circuit Example

Note: The application circuit shown in this document is provided for reference purposes only. The data for mass production are not guaranteed.

Table 21 Component values (for reference only)

Part's symbol	Component	Value
CVM1	Electrolytic capacitor	47 μ F
CVM2	Ceramic capacitor	0.1 μ F
CVREF	Ceramic capacitor	0.1 μ F
CEN	Ceramic capacitor	22 nF
ROSC	Resistor	47 k Ω
REN	Resistor	10 k Ω

Note: Component values in above table are for reference only. Some components other than reference value can be adopted depending on the usage conditions.

22. Package Dimensions

P-VQFN16-0303-0.50-001

Unit: mm

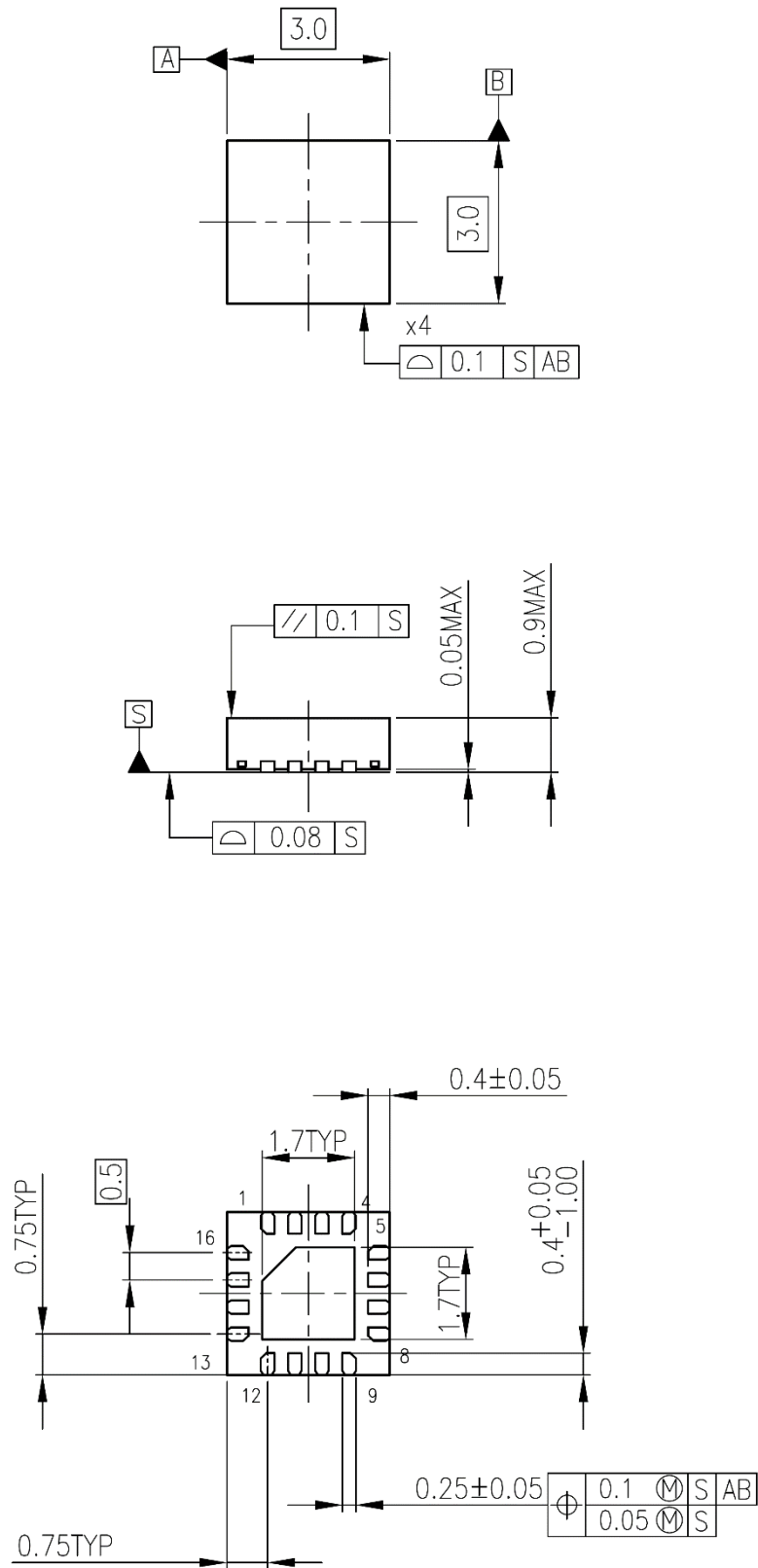

Figure 22 Package Dimensions

Weight: 22.9 mg (typ.)

23. Notes on Contents

Block Diagrams

Some of the functional blocks, circuits, or constants in the block diagram may be omitted or simplified for explanatory purposes.

Timing Charts

Timing charts may be simplified for explanatory purposes.

Application Circuits

The application circuits shown in this document are provided for reference purposes only. Thorough evaluation is required, especially at the mass production design stage. Providing these application circuit examples does not grant a license for industrial property rights.

24. IC Usage Considerations

24.1. Notes on Handling of ICs

- (1) The absolute maximum ratings of a semiconductor device are a set of ratings that must not be exceeded, even for a moment. Do not exceed any of these ratings. Exceeding the rating(s) may cause the device breakdown, damage or deterioration, and may result injury by explosion or combustion.
- (2) Use an appropriate power supply fuse to ensure that a large current does not continuously flow in case of over current and/or IC failure. The IC will fully break down when used under conditions that exceed its absolute maximum ratings, when the wiring is routed improperly or when an abnormal pulse noise occurs from the wiring or load, causing a large current to continuously flow and the breakdown can lead smoke or ignition. To minimize the effects of the flow of a large current in case of breakdown, appropriate settings, such as fuse capacity, fusing time and insertion circuit location, are required.
- (1) If your design includes an inductive load such as a motor coil, incorporate a protection circuit into the design to prevent device malfunction or breakdown caused by the current resulting from the inrush current at power ON or the negative current resulting from the back electromotive force at power OFF. IC breakdown may cause injury, smoke or ignition. Use a stable power supply with ICs with built-in protection functions. If the power supply is unstable, the protection function may not operate, causing IC breakdown. IC breakdown may cause injury, smoke or ignition.
- (2) Do not insert devices in the wrong orientation or incorrectly. Make sure that the positive and negative terminals of power supplies are connected properly. Otherwise, the current or power consumption may exceed the absolute maximum rating, and exceeding the rating(s) may cause the device breakdown, damage or deterioration, and may result injury by explosion or combustion. In addition, do not use any device that is applied the current with inserting in the wrong orientation or incorrectly even just one time.
- (3) Carefully select external components (such as inputs and negative feedback capacitors) and load components (such as speakers), for example, power amp and regulator. If there is a large amount of leakage current such as from input or negative feedback condenser, the IC output DC voltage will increase. If this output voltage is connected to a speaker with low input withstand voltage, overcurrent or IC failure may cause smoke or ignition. (The overcurrent may cause smoke or ignition from the IC itself.) In particular, please pay attention when using a Bridge Tied Load (BTL) connection-type IC that inputs output DC voltage to a speaker directly.

24.2. Points to Remember on Handling of ICs

(1) Over current Protection Circuit

Over current protection circuits (referred to as current limiter circuits) do not necessarily protect ICs under all circumstances. If the Over current protection circuits operate against the over current, clear the over current status immediately.

Depending on the method of use and usage conditions, such as exceeding absolute maximum ratings can cause the over current protection circuit to not operate properly or IC breakdown before operation. In addition, depending on the method of use and usage conditions, if over current continues to flow for a long time after operation, the IC may generate heat resulting in breakdown.

(2) Thermal Shutdown Circuit

Thermal shutdown circuits do not necessarily protect ICs under all circumstances. If the thermal shutdown circuits operate against the over temperature, clear the heat generation status immediately.

Depending on the method of use and usage conditions, such as exceeding absolute maximum ratings can cause the thermal shutdown circuit to not operate properly or IC breakdown before operation.

(3) Heat Radiation Design

In using an IC with large current flow such as power amp, regulator or driver, please design the device so that heat is appropriately radiated, not to exceed the specified junction temperature (T_j) at any time and condition.

These ICs generate heat even during normal use. An inadequate IC heat radiation design can lead to decrease in IC life, deterioration of IC characteristics or IC breakdown. In addition, please design the device taking into considerate the effect of IC heat radiation with peripheral components.

(4) Back-EMF

When a motor reverses the rotation direction, stops or slows down abruptly, a current flow back to the motor's power supply due to the effect of back-EMF. If the current sink capability of the power supply is small, the device's motor power supply and output pins might be exposed to conditions beyond absolute maximum ratings. To avoid this problem, take the effect of back-EMF into consideration in system design.

RESTRICTIONS ON PRODUCT USE

- Toshiba Corporation and its subsidiaries and affiliates are collectively referred to as "TOSHIBA". Hardware, software and systems described in this document are collectively referred to as "Product".
- TOSHIBA reserves the right to make changes to the information in this document and related Product without notice.
- This document and any information herein may not be reproduced without prior written permission from TOSHIBA. Even with TOSHIBA's written permission, reproduction is permissible only if reproduction is without alteration/omission.
- Though TOSHIBA works continually to improve Product's quality and reliability, Product can malfunction or fail. Customers are responsible for complying with safety standards and for providing adequate designs and safeguards for their hardware, software and systems which minimize risk and avoid situations in which a malfunction or failure of Product could cause loss of human life, bodily injury or damage to property, including data loss or corruption. Before customers use the Product, create designs including the Product, or incorporate the Product into their own applications, customers must also refer to and comply with (a) the latest versions of all relevant TOSHIBA information, including without limitation, this document, the specifications, the data sheets and application notes for Product and the precautions and conditions set forth in the "TOSHIBA Semiconductor Reliability Handbook" and (b) the instructions for the application with which the Product will be used with or for. Customers are solely responsible for all aspects of their own product design or applications, including but not limited to (a) determining the appropriateness of the use of this Product in such design or applications; (b) evaluating and determining the applicability of any information contained in this document, or in charts, diagrams, programs, algorithms, sample application circuits, or any other referenced documents; and (c) validating all operating parameters for such designs and applications. **TOSHIBA ASSUMES NO LIABILITY FOR CUSTOMERS' PRODUCT DESIGN OR APPLICATIONS.**
- **PRODUCT IS NEITHER INTENDED NOR WARRANTED FOR USE IN EQUIPMENTS OR SYSTEMS THAT REQUIRE EXTRAORDINARILY HIGH LEVELS OF QUALITY AND/OR RELIABILITY, AND/OR A MALFUNCTION OR FAILURE OF WHICH MAY CAUSE LOSS OF HUMAN LIFE, BODILY INJURY, SERIOUS PROPERTY DAMAGE AND/OR SERIOUS PUBLIC IMPACT ("UNINTENDED USE").** Except for specific applications as expressly stated in this document, Unintended Use includes, without limitation, equipment used in nuclear facilities, equipment used in the aerospace industry, Class 3 medical devices, equipment used for automobiles, and military vehicles and munitions. **IF YOU USE PRODUCT FOR UNINTENDED USE, TOSHIBA ASSUMES NO LIABILITY FOR PRODUCT.** For details, please contact your TOSHIBA sales representative or contact us via our website.
- Do not disassemble, analyze, reverse-engineer, alter, modify, translate or copy Product, whether in whole or in part.
- Product shall not be used for or incorporated into any products or systems whose manufacture, use, or sale is prohibited under any applicable laws or regulations.
- The information contained herein is presented only as guidance for Product use. No responsibility is assumed by TOSHIBA for any infringement of patents or any other intellectual property rights of third parties that may result from the use of Product. No license to any intellectual property right is granted by this document, whether express or implied, by estoppel or otherwise.
- **ABSENT A WRITTEN SIGNED AGREEMENT, EXCEPT AS PROVIDED IN THE RELEVANT TERMS AND CONDITIONS OF SALE FOR PRODUCT, AND TO THE MAXIMUM EXTENT ALLOWABLE BY LAW, TOSHIBA (1) ASSUMES NO LIABILITY WHATSOEVER, INCLUDING WITHOUT LIMITATION, INDIRECT, CONSEQUENTIAL, SPECIAL, OR INCIDENTAL DAMAGES OR LOSS, INCLUDING WITHOUT LIMITATION, LOSS OF PROFITS, LOSS OF OPPORTUNITIES, BUSINESS INTERRUPTION AND LOSS OF DATA, AND (2) DISCLAIMS ANY AND ALL EXPRESS OR IMPLIED WARRANTIES AND CONDITIONS RELATED TO SALE, USE OF PRODUCT, OR INFORMATION, INCLUDING WARRANTIES OR CONDITIONS OF MERCHANTABILITY, FITNESS FOR A PARTICULAR PURPOSE, ACCURACY OF INFORMATION, OR NONINFRINGEMENT.**
- Do not use or otherwise make available Product or related software or technology for any military purposes, including without limitation, for the design, development, use, stockpiling or manufacturing of nuclear, chemical, or biological weapons or missile technology products (mass destruction weapons). Product and related software and technology may be controlled under the applicable export laws and regulations including, without limitation, the Japanese Foreign Exchange and Foreign Trade Law and the U.S. Export Administration Regulations. Export and re-export of Product or related software or technology are strictly prohibited except in compliance with all applicable export laws and regulations.
- Please contact your TOSHIBA sales representative for details as to environmental matters such as the RoHS compatibility of Product. Please use Product in compliance with all applicable laws and regulations that regulate the inclusion or use of controlled substances, including without limitation, the EU RoHS Directive. **TOSHIBA ASSUMES NO LIABILITY FOR DAMAGES OR LOSSES OCCURRING AS A RESULT OF NONCOMPLIANCE WITH APPLICABLE LAWS AND REGULATIONS.**