

TB9057FG

Automotive GATE-driver for DC brushed motor driver

TB9057FG is a Pre-Driver IC for DC Brushed Motor. It controls motor speed by inputting PWM signal. The IC has charge pump, motor current detection circuit, motor driving direction detection circuit and oscillator in it. Also, it has various abnormality detection circuits, and the detection condition can be adjusted by external pin setting.

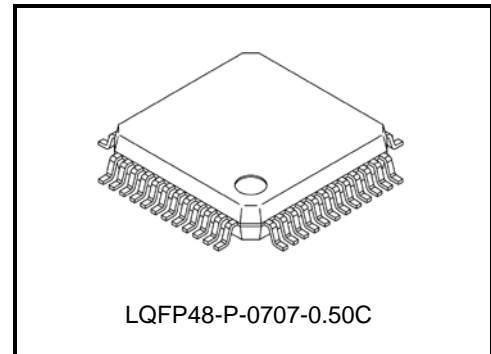

Weight: 0.186g (typ.)

1. Features

- Control motor speed by Inputting PWM signal
- Build-in charge pump
- Current detection circuit
- Detection circuit for Motor driving direction
- Various abnormality detection circuits (Over temperature / Low voltage / Short detection)
- Operating range of voltage : 5 to 21V
- Operating range of temperature : -40 to 125°C
- Small size flat package : LQFP48-P-0707-0.50C (0.5mm Pitch)
- The product(s) is/are compatible with RoHS regulations (EU directive 2011 / 65 / EU) as indicated, if any, on the packaging label ("[[G]]/RoHS COMPATIBLE", "[[G]]/RoHS [[Chemical symbol(s) of controlled substance(s)]]", "RoHS COMPATIBLE" or "RoHS COMPATIBLE, [[Chemical symbol(s) of controlled substance(s)]]>MCV").
- AEC-Q100 Qualified
- Developed according to ISO 26262 ASIL-D
- Safety Manual and Safety Analysis Report
- Over temperature dection is duplicated

2. BLOCK DIAGRAM

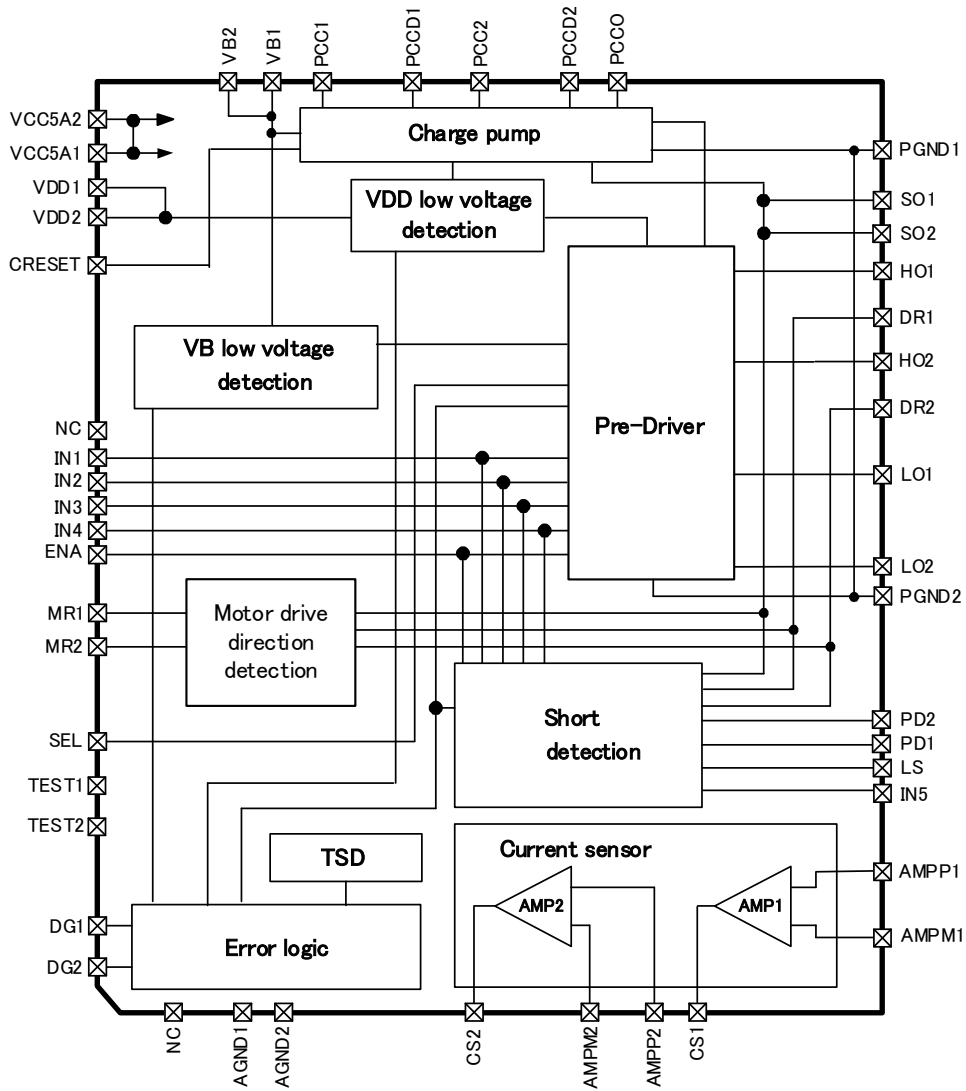

Note 1 : Some of the functional blocks,circuit,or constants in the block diagram may be omitted or simplified for explanatory purpose.

3. PACKAGE PIN LAYOUT

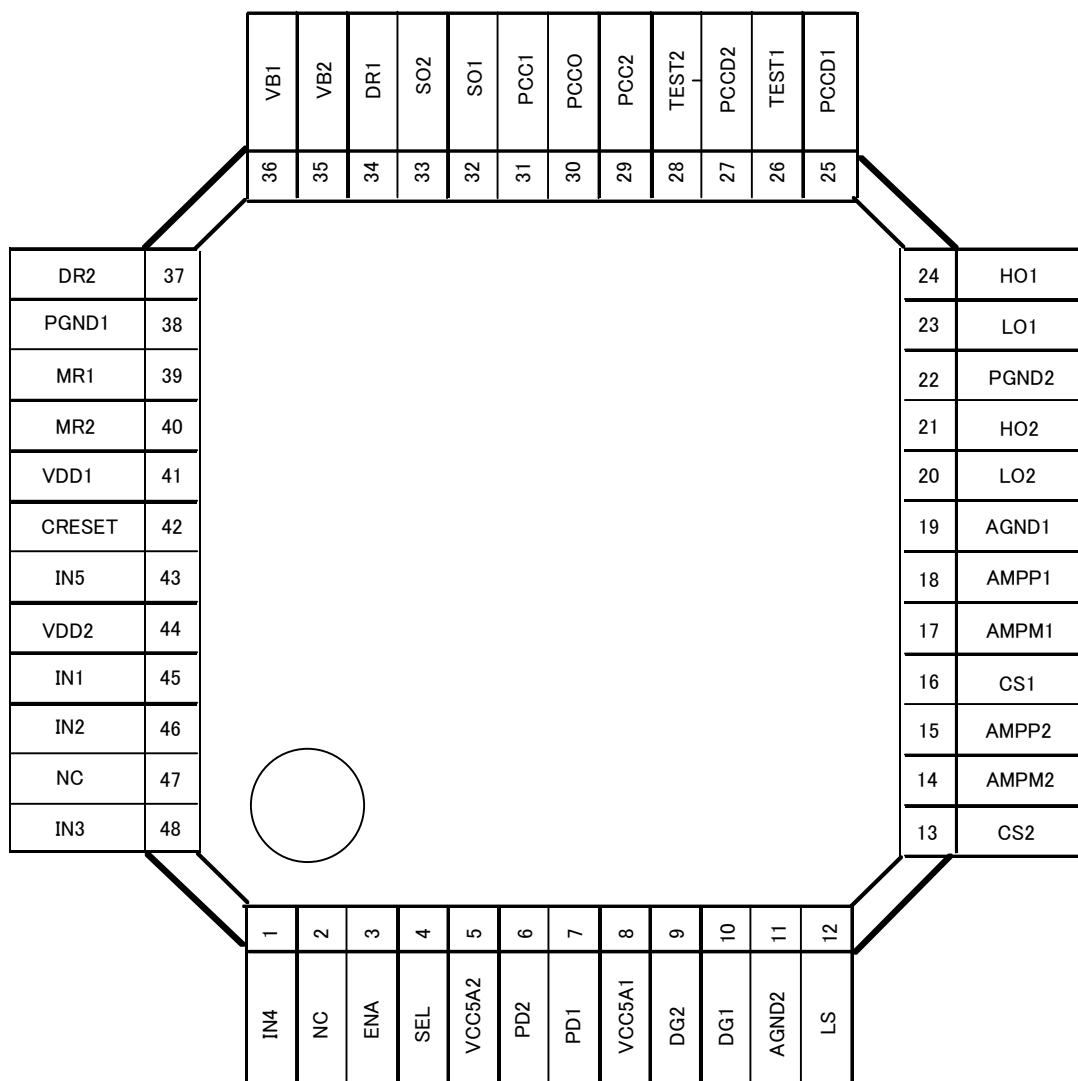

4. PIN DESCRIPTION

PIN No.	Symbol	Description	IN/OUT	Internal IC	Notes
1	IN4	Pre-Driver Direct Control 4	I	Pull-up	
2	NC	Non Connection Pin	-	-	Please use OPEN (No B`g wire)
3	ENA	Pre-Driver Enable Signal	I	Pull-down	
4	SEL	Select control method for abnormality detection	I	Pull-up	
5	VCC5A2	Power Supply for Analog 2	-	-	
6	PD2	Set reference voltage for Short Detection 2	I	-	
7	PD1	Set reference voltage for Short Detection 1	I	-	
8	VCC5A1	Power Supply for Analog 1	-	-	
9	DG2	Output of error logic detection 2	O	-	
10	DG1	Output of error logic detection 1	O	-	
11	AGND2	Analog GND 2	-	-	
12	LS	Pre-Driver Low-side Source Input	I	-	
13	CS2	2nd AMP. Output for Current detection	O	-	
14	AMPM2	2nd AMP. - Input for Current detection	I	-	
15	AMPP2	2nd AMP. + Input for Current detection	I	-	
16	CS1	1st AMP. Output for Current detection	O	-	
17	AMPM1	1st AMP. - Input for Current detection	I	-	
18	AMPP1	1st AMP. + Input for Current detection	I	-	
19	AGND1	Analog GND 1	-	-	
20	LO2	Output of Pre-Driver L2	O	-	
21	HO2	Output of Pre-Driver H2	O	-	
22	PGND2	Power GND 2	-	-	
23	LO1	Output of Pre-Driver L1	O	-	
24	HO1	Output of Pre-Driver H1	O	-	
25	PCCD1	1st Charge Pump Drive Output	O	-	
26	TEST1	TEST PIN 1	I	Pull-down	Please use OPEN
27	PCCD2	2nd Charge Pump Drive Output	O	-	
28	TEST2	TEST PIN 2	I	Pull-down	Please use OPEN
29	PCC2	2nd Charge Pump Output	O	-	
30	PCCO	Final Charge Pump Output	O	-	
31	PCC1	1st Charge Pump Output	O	-	
32	SO1	Pre-Driver High-side Drain Input 1	I	-	
33	SO2	Pre-Driver High-side Drain Input 2	I	-	
34	DR1	Motor Connect PIN 1	I	Pull-down	
35	VB2	Power Supply(Battery 12V) 2	-	-	
36	VB1	Power Supply(Battery 12V) 1	-	-	
37	DR2	Motor Connect PIN 2	I	Pull-down	
38	PGND1	Power GND 1	-	-	
39	MR1	Motor driving direction detection signal 1	O	-	
40	MR2	Motor driving direction detection signal 2	O	-	
41	VDD1	Power supply for logic 1	-	-	
42	CRESET	Charge pump reset signal	I	Pull-up	
43	IN5	Set filter time for short detection	I	-	
44	VDD2	Power supply for logic 2	-	-	
45	IN1	Pre-Driver Direct Control 1	I	Pull-up	
46	IN2	Pre-Driver Direct Control 2	I	Pull-up	
47	NC	Non Connection Pin	-	-	Please use OPEN (No B`g wire)
48	IN3	Pre-Driver Direct Control 3	I	Pull-up	

Note 1 : If the soldering comes off, it may cause that motor does not rotate, motor rotation is unstable or motor protection is not operated.

Note 2 : In case of neighboring pin short, it may cause break down of IC or damage to the product.

Note 3 : Install the product correctly. Otherwise, it may cause break down of IC or damage to the product.

5. FUNCTIONAL DESCRIPTIONS

TB9057FG is a Pre-Driver IC for DC Brushed Motor.

TB9057FG has charge pump in it, so that it can control external Nch MOSFET directly. And the IC is able to detect the motor current from CS1 and CS2 pin by using the internal current detection circuit.

Also, it has various abnormality detection circuits, and the detection condition can be adjusted by external pin setting.

5.1. Charge Pump

In order to operate the external Nch MOSFET, TB9057FG has pre-driver. And the charge pump is built-in to operate the pre-driver. The charge pump voltage is monitored by internal circuit, and controlled as described below.

The charge pump voltage (PCCO pin) has 2 types of detection and clamp function. When the voltage rises up to $SO+12V$, the operation of charge pump would be stopped. And it re-starts the operation when the voltage falls down to $SO+11.9V$. To prevent the over voltage, if the voltage rises up to 36V, the operation of charge pump would be stopped until the voltage falls down to 35.5V.

Charge Pump Operation can be stopped by using external PIN "CRESET".

CRESET = High : Normal operation. CRESET = Low : Stop the operation of charge pump.

When charge pump is stopped, PCCO voltage become "VB-3VF".

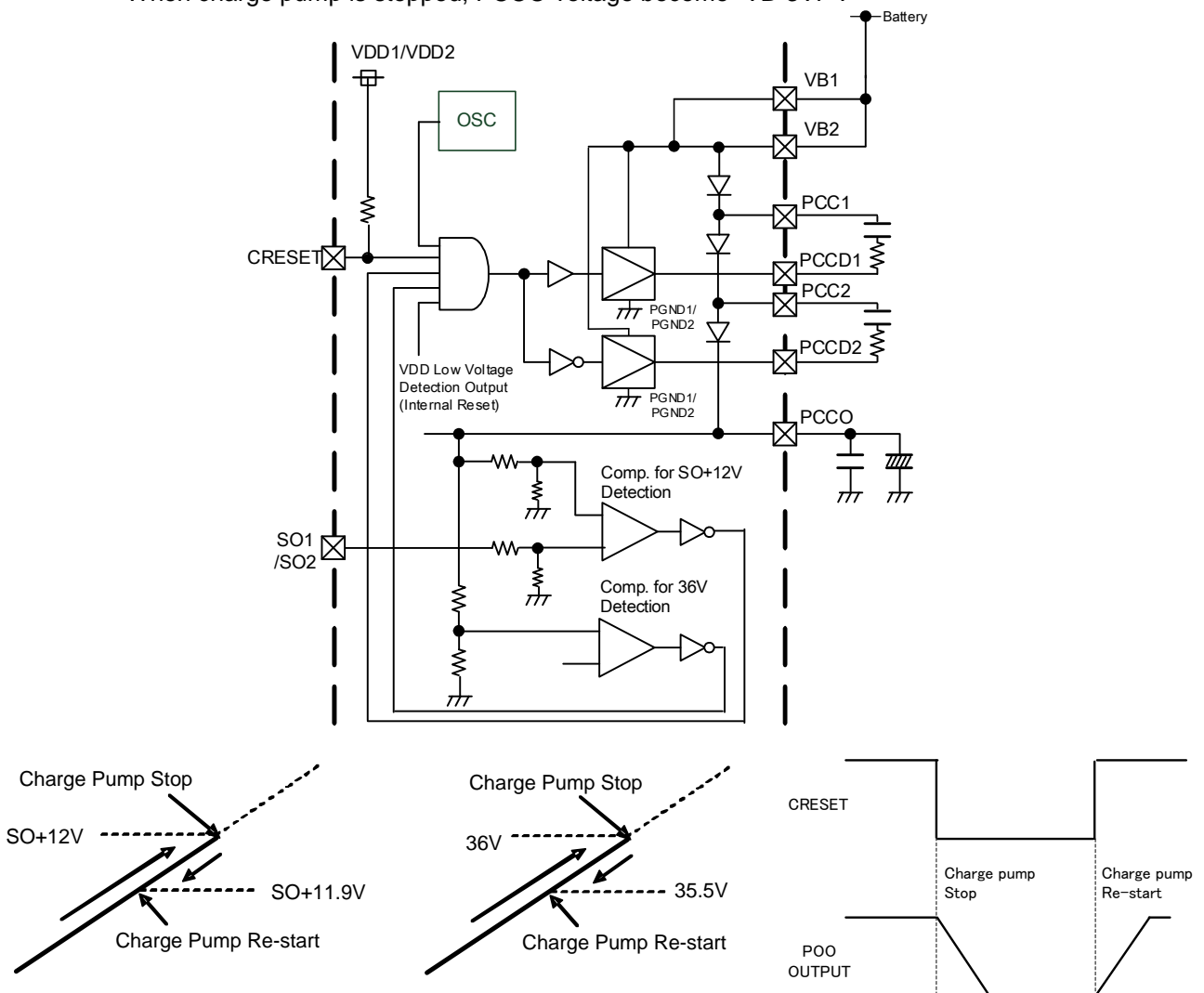

Note 1 : When VB is over 40V, it exceeds the absolute maximum rating of PCCO (40V), even if the charge pump is stopped as shown above. Please make sure not to exceed 40V at VB

Note 2 : Some of the functional blocks, circuits, or constants in the block diagram may be omitted or simplified for explanatory purpose.

Note 3 : The timing charts is to describe the function and operation of IC. Therefore it is different from the actual wave form of the IC.

5.2. Pre-Driver Circuit

The pre-driver circuit is operated by IN1 to IN4 pin. And the output voltage of charge pump is used as the power supply. The operation of pre-driver would be stopped when the ENA pin = Low.

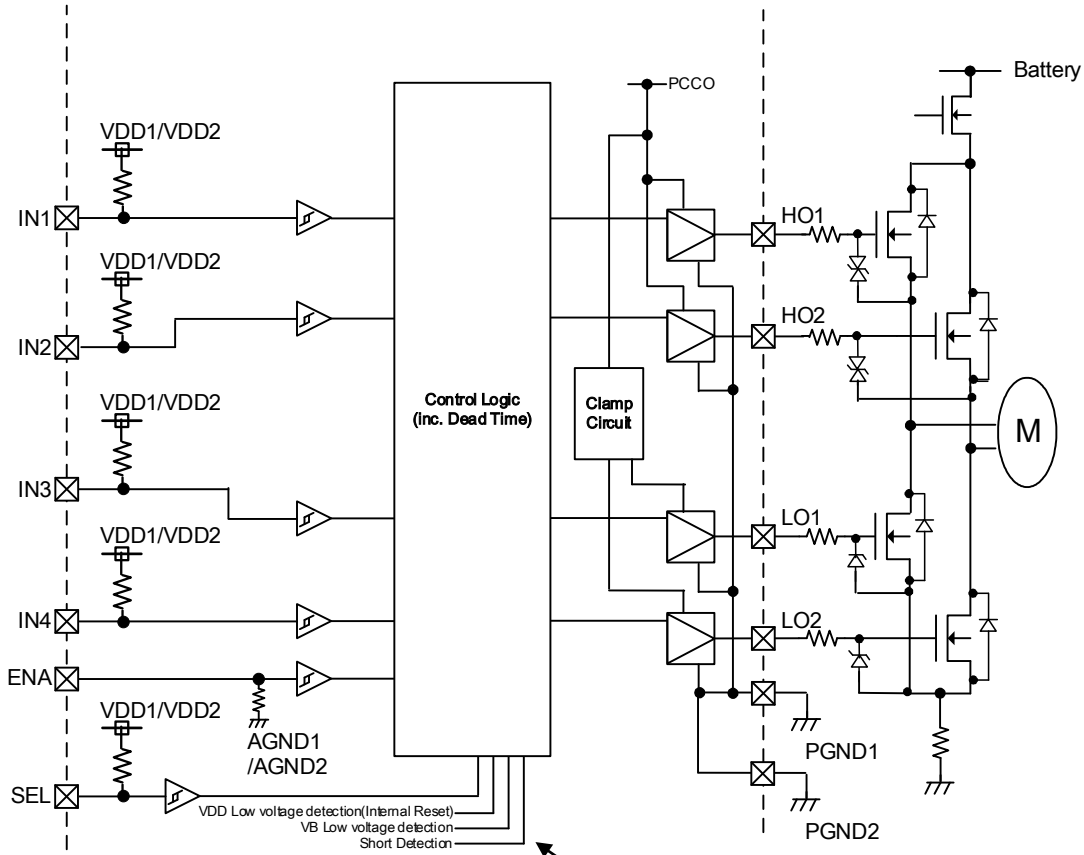

Please refer to the description of 5.5. Abnormality detection

Note 1 : Some of the functional blocks, circuits, or constants in the block diagram may be omitted or simplified for explanatory purpose.

Truth Table

Input Signal					Output Signal			
IN1	IN2	IN3	IN4	ENA	HO1	HO2	LO1	LO2
L	*	L	*	H	L	L	L	L
*	L	*	L	H	L	L	L	L
L	L	H	H	H	H	H	L	L
L	H	H	L	H	H	L	L	H
H	L	L	H	H	L	H	H	L
H	H	L	L	H	L	L	H	H
L	H	H	H	H	H	L	L	L
H	L	H	H	H	L	H	L	L
H	H	L	H	H	L	L	H	L
H	H	H	L	H	L	L	L	H
H	H	H	H	H	L	L	L	L
*	*	*	*	L	L	L	L	L

* : Don't care.

* DEAD TIME generation

To prevent the short current by simultaneous turning on both Low-side and High-side, which compose the each of half-bridge at the H-bridge circuit, the IC generates dead time at the timing of driver [OFF to ON] as shown below.

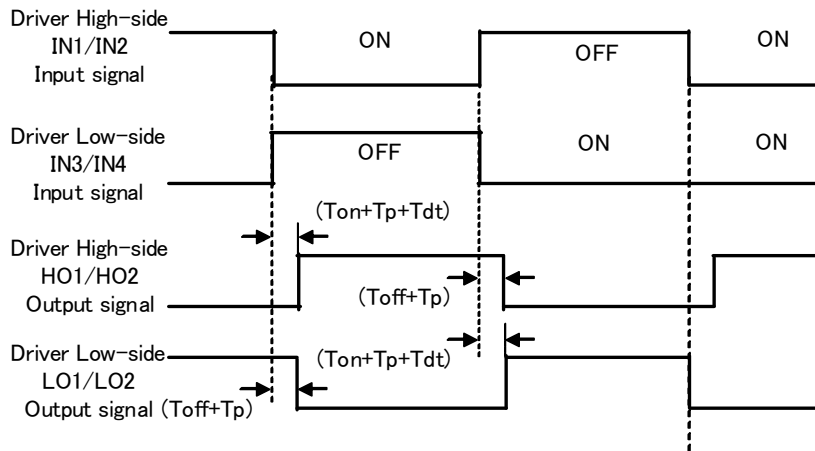

Note 1: The timing charts is to describe the function and operation of IC. Therefore it is different from the actual wave form of the IC.

5.3. Current detection circuit

Current detection circuit could be used for detecting the motor current. By using external shunt resistor, it converts the motor current to voltage. The amplification rate of differential circuit can be adjusted by changing the value of external resistor.

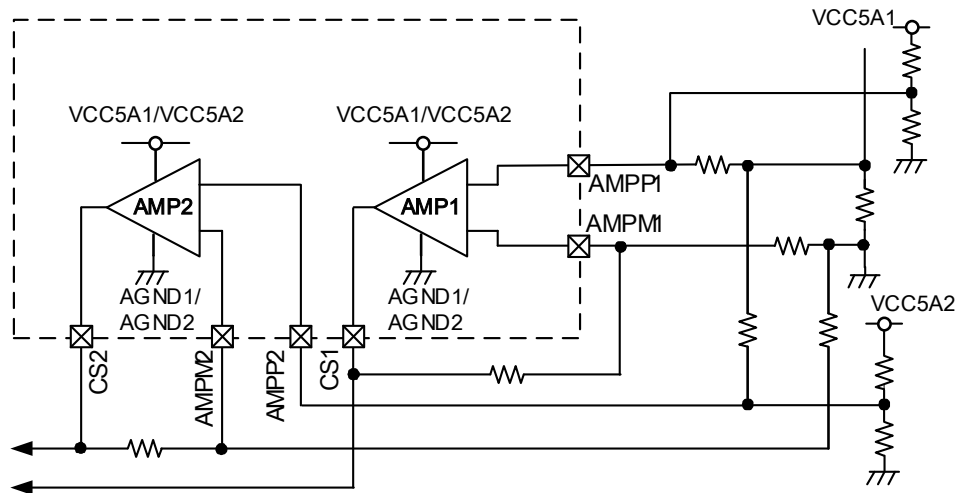

Note 1: Some of the functional blocks, circuits, or constants in the block diagram may be omitted or simplified for explanatory purpose.

5.4. Motor driving direction detection

The IC has the motor driving direction detection circuit. To monitor the reverse assist, it can detect whether the external MOSFET turns on normally, as following the driver turning on command.

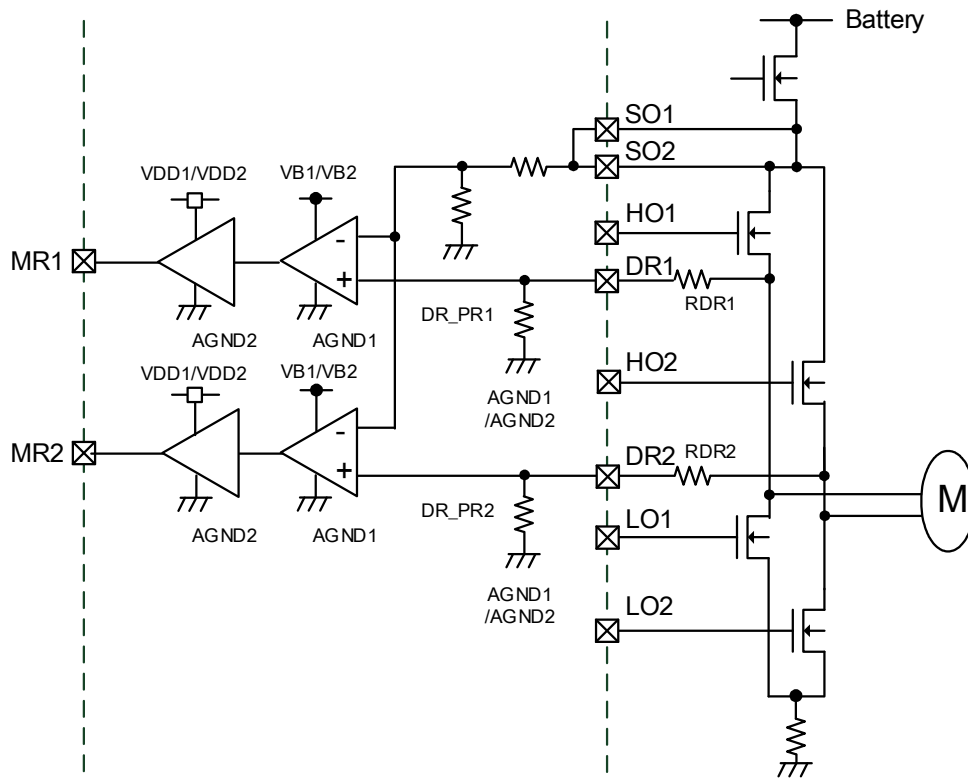

Note 1 : Some of the functional blocks, circuits, or constants in the block diagram may be omitted or simplified for explanatory purpose.

Truth Table

Input Signal				Output Signal	
HO1	HO2	LO1	LO2	DR1	DR2
L	L	L	L	Hi-Z(Open)	Hi-Z(Open)
H	H	L	L	H	H
H	L	L	H	H	L
L	H	H	L	L	H
L	L	H	H	L	L
H	L	L	L	H	Hi-Z(Open)
L	H	L	L	Hi-Z(Open)	H
L	L	H	L	L	Hi-Z(Open)
L	L	L	H	Hi-Z(Open)	L

Input Signal		Output Signal	
DR1	DR2	MR1	MR2
Hi-Z(Open)	Hi-Z(Open)	L	L
H	H	H	H
H	L	H	L
L	H	L	H
L	L	L	L
H	Hi-Z(Open)	H	L
Hi-Z(Open)	H	L	H
L	Hi-Z(Open)	L	L
Hi-Z(Open)	L	L	L

5.5. Abnormality detection circuit

TB9057FG has various abnormality detection functions like low voltage detection, over temperature detection, external MOSFET short detection and motor short detection circuit.

In case of low voltage detection, DG1=Low, DG2=Low.

In case of over temperature detection, DG1=High, DG2=High.

In case of short detection, DG1=Low, DG2=High.

And if it returns to the normal operation, DG1=High, DG2=Low.

PIN"DG1"	PIN"DG2"	Description
H	L	Normal
L	L	VB low voltage or VDD low voltage detection
L	H	MOSFET or motor short detection
H	H	Over temperature detection

Priority of each detection is as follow.

Low voltage detection > over temperature detection > short detection

5.5.1. VB low voltage detection / VDD low voltage detection

5.5.1.1. VB low voltage detection

When VB is dropped to lower than 4.0V, DG1=Low and DG2=Low.

When VB is increased over 4.5V, it re-starts the low voltage detection and restore to the normal operation, as DG1=High and DG2=Low.

Also, in case of the low voltage detection, the pre-driver output could be controlled by the pin SEL.

When pin SEL=Low, HO1,HO2,LO1 and LO2 become Low, regardless of the input conditions.

When pin SEL=High, the pre-driver keeps normal operation.

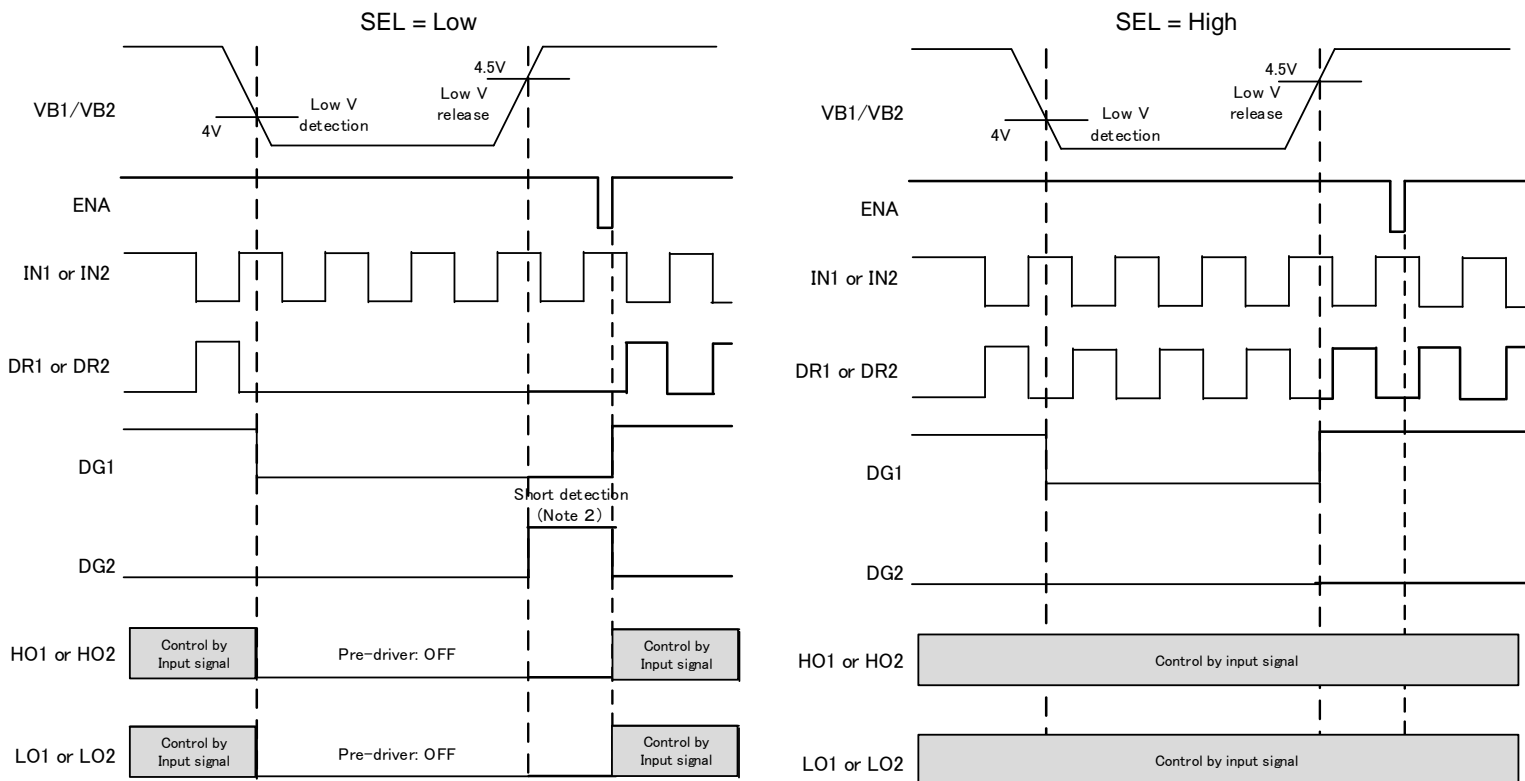

Note 1: The timing charts is to describe the function and operation of IC. Therefore it is different from the actual wave form of the IC.

Note 2: Only when SEL=Low, it moves to the short detection after releasing the VB low voltage detection. (Regardless of the IN input, driver=Low (hold) and DG1/DG2=Low/High (hold))

Therefore in order to re-start the normal operation, please change the ENA signal from Low to High.

5.5.1.2. VDD low voltage detection (internal power-on reset function)

As comparing with the internal band gap voltage, it detects the low voltage by monitoring the external supply voltage of VDD that is applied to VDD1/VDD2. When VDD is dropped to lower than the reset voltage, charge pump would be stopped and the pre-driver output becomes OFF. When it increases to higher than the release voltage, the internal reset would be released and it becomes normal operation. The reset detection voltage sets up the hysteresis width. Also, both of internal reset detection signal and release signal have chattering prevention circuit, so that it can be designed with considering to prevent the operation error.

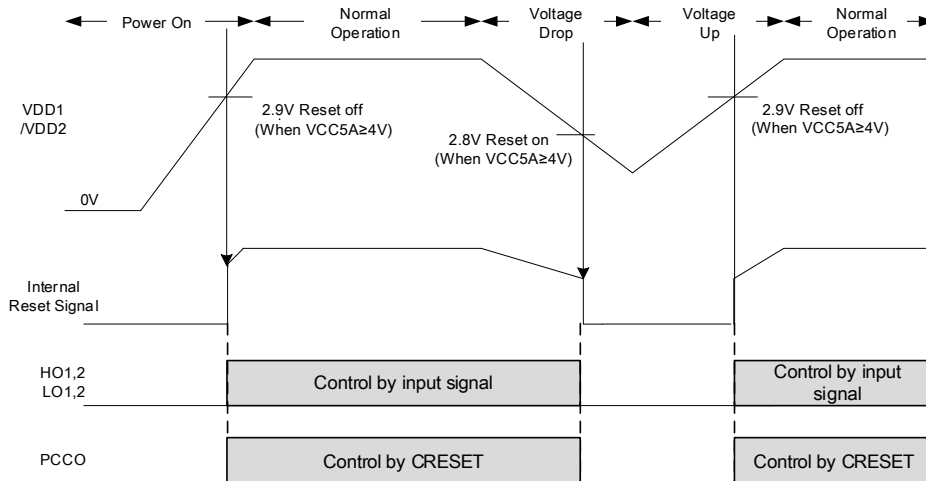

Note 1: The timing charts is to describe the function and operation of IC. Therefore it is different from the actual wave form of the IC.

5.5.2. Over temperature detection

When the chip temperature is over 170°C, pin DG1=High and DG2=High. And when the chip temperature is dropped to lower than 160°C, it releases the over temperature detection and DG1=High, DG2=Low. As considering the functional safety, the over temperature is duplicated.

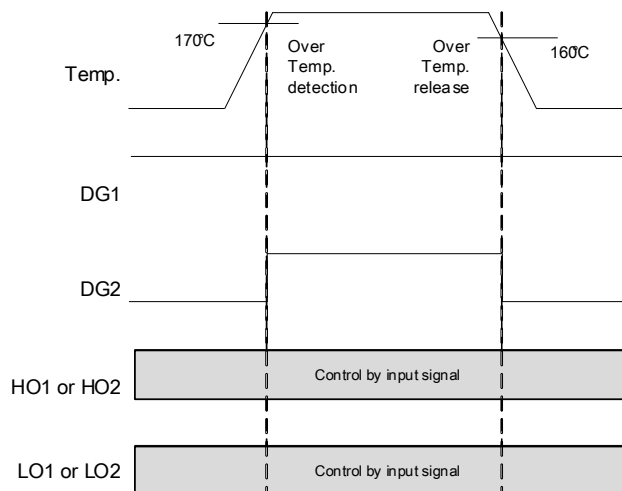

Note 1 : The guaranteed storage temperature from the absolute maximum rating is 150°C. If the IC is used or preserved under the over temperature, the normal operation is not guarantee, and also it may cause smoking and ignition. Be sure not to exceed the temperature in any case. The IC has the over temperature detection function but it does not intend to limit the IC temperature under 150°C and as it does not guarantee the operation, it regards as an additional function.

5.5.3. Short detection

The short detection of both MOSFET and motor would be implemented by monitoring the voltage between source pin and drain pin of external driver.

If it detects the short, than $DG1=Low$ and $DG2=High$ (latch). When the short detection is released by the ENA signal, it becomes $DG1=High$ and $DG2=Low$. And then it restores to the normal operation. Also, pre-driver output can be controlled during the short detection by the SEL pin.

When $SEL=Low$, $HO1,HO2,LO1$ and $LO2$ become Low, regardless of the input conditions.

When $SEL=High$, the pre-driver keeps normal operation.

Short detection circuit has filter time to prevent the wrong detection caused by the switching noise during driver ON. The filter time could be set by the resistor value connected to $IN5$.

The short detection voltage can be set by the supplied voltage at PD pin.

In addition, even if $ENA=L$ or inputting inhibit logic, the short detection circuit operates normally.

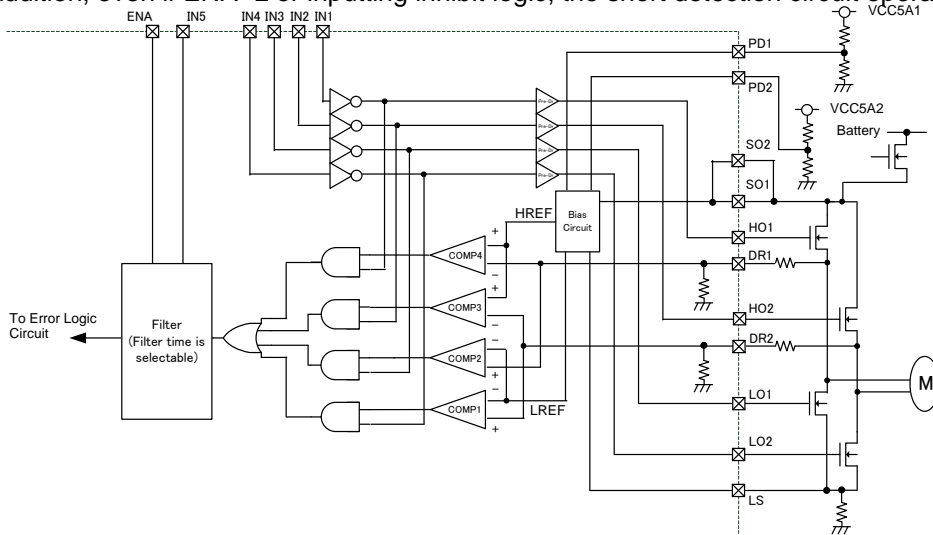

Note 1 : Some of the functional blocks, circuits, or constants in the block diagram may be omitted or simplified for explanatory purpose.

Note 2 : In case $18 < SO \leq 21V$, due to the reverse output error of the comparator (COMP3/COMP4) at high-side, the error logic could have the reverse output error, too.

Comparator Input	Comparator output	PWM Input	Abnormal Phenomenon
$DR1 > LREF$	COMP2 = H	IN3 = L	HO1 external MOSFET Short or Motor Line Short
$DR2 > LREF$	COMP1 = H	IN4 = L	HO2 external MOSFET Short or Motor Line Short
$DR1 < HREF$	COMP4 = H	IN1 = L	LO1 external MOSFET Short or Motor Line Short
$DR2 < HREF$	COMP3 = H	IN2 = L	LO2 external MOSFET Short or Motor Line Short

*HREF = SO voltage - PD1 voltage, LREF = LS voltage + PD2 voltage

< MOSFET Short Detection >

• SEL = Low

<Low-side MOSFET Short>

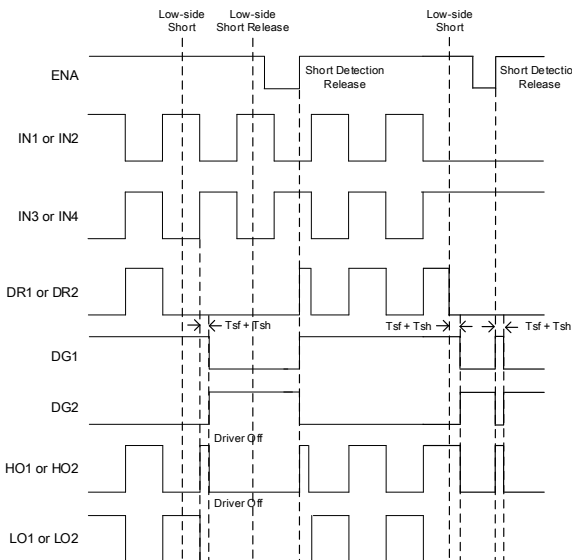

<High-side MOSFET Short>

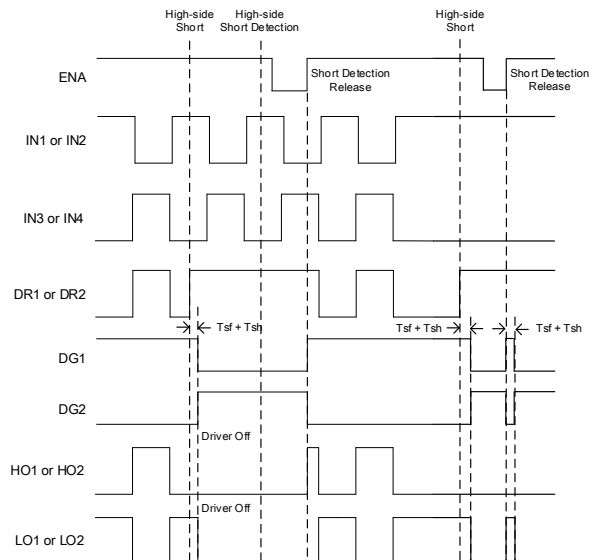

• SEL = High

<Low-side MOSFET Short>

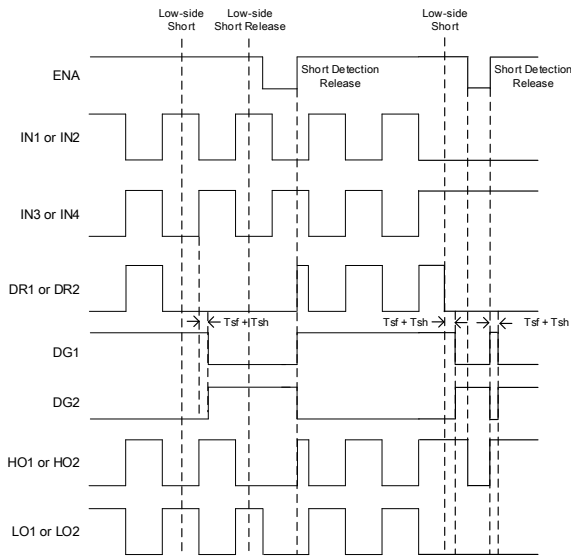

<High-side MOSFET Short>

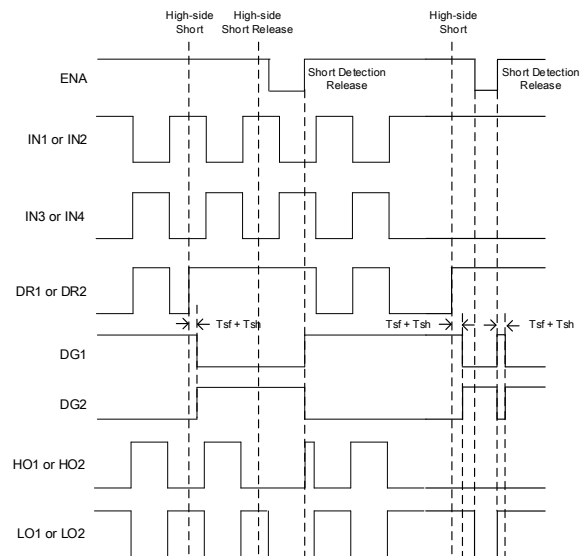

< Motor Short Detection >

SEL = Low

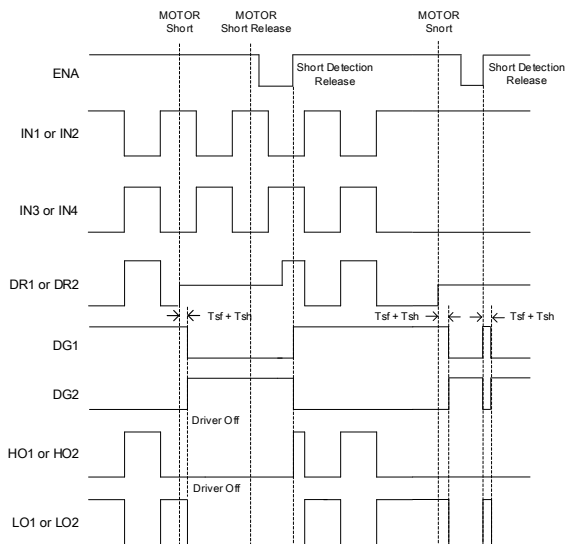

SEL = High

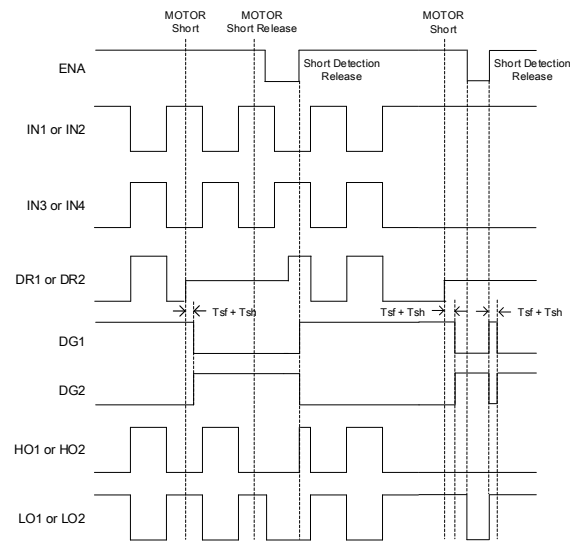

Note 1: The timing charts is to describe the function and operation of IC. Therefore it is different from the actual wave form of the IC.

6. ABSOLUTE MAXIMUM RATING (Ta = -40 to 125°C)

CHARACTERISTIC	SYMBOL	PIN	VALUE	UNIT		
Input/Output Voltage	Vin, Vout	VB1, VB2, DR1, DR2, SO1, SO2	-0.3 to 21(DC)	V		
			21 to 24(1ms)			
			24 to 40(1s)			
				PCC1, PCCD1, PCC2, PCCD2, PCCO, HO1, HO2, TEST1, TEST2	-0.3 to 40(1s)	V
				LO1, LO2	-0.3 to PCCO (PCCO≤14V)	V
				VCC5A1, VCC5A2, VDD1, VDD2	-0.3 to 6	V
				CS1, CS2, LS, IN5, PD1, PD2, AMPP1, AMPM1, AMPP2, AMPM2	-0.3 to VCC5A+0.3 (max: 6V)	V
		IN1, IN 2, IN 3, IN 4, ENA, SEL, DG1, DG2, CRESET, MR1, MR2	-0.3 to VDD+0.3 (max: 6V)	V		
Input Current	lin	DR1, DR2	-50	mA		
Output Current	Iout	HO1, HO2, LO1, LO2, PCCD1, PCCD2	±1(1μs)	A		
		CS1, CS2	±10	mA		
		PCC1, PCC2, PCCO	±100	mA		
		DG1, DG2	±10	mA		
		MR1, MR2	±10	mA		
Storage Temperature	Tstg	-	-55 to 150	°C		
Power dissipation	PD	(In case of JEDEC 4layer board)	0.4(Ta=125°C)	W		

Note 1: The absolute maximum ratings of a semiconductor device are a set of specified parameter values, which must not be exceeded during operation, even for an instant. If any of these rating would be exceeded during operation, the device electrical characteristics may be irreparably altered and the reliability and lifetime of the device can no longer be guaranteed. Moreover, these operations with exceeded ratings may cause break down, damage and/or degradation to any other equipment. Applications using the device should be designed such that each maximum rating will never be exceeded in any operating conditions. Before using, creating and/or producing designs, refer to and comply with the precautions and conditions set forth in these documents.

Note 2: About the current, it defines IC_Sink as (+) and IC_Source as (-).

7. STATIC ELECTRICAL CHARACTERISTICS

7.1. Operating Voltage Range (unless otherwise specified, operating range is as below)

CHARACTERISTIC	SYMBOL	PIN	VALUE	UNIT
Supply Voltage	Vin	VB1, VB2, SO1, SO2	5 to 21 *VB≥VCC5A,VDD* VB≥SO-1V	V
		VCC5A1, VCC5A2	4 to 5.5 *VCC5A≥VDD	V
		VDD1, VDD2	3 to 5.5	V
Operating Temperature	Topr	-	-40 to 125	°C

*VB: a voltage applied to VB1/VB2

*VCC5A: a voltage applied to VCC5A1/VCC5A2

*VDD: a voltage applied to VDD1/VDD2

7.2. IC Characteristics

CHARACTERISTIC	SYMBOL	PIN	CONDITION	MIN	TYP.	MAX	UNIT
Current Consumption(VB)	lvb1	VB1, VB2	CRESET=Low	-	1.5	3	mA
	lvb2	VB1, VB2	CRESET=High HO1,HO2=20kHz Cload=10nF Roh=100Ω	-	50	70	mA
Current Consumption(VCC5A)	lvcc5a	VCC5A1, VCC5A2	-	-	4	5.5	mA
Output Voltage "H"	Voh	DG1, DG2	Iload = -1mA	0.8x VDD	-	VDD	V
Output Voltage "L"	Vol		Iload = 1mA	-	-	0.2x VDD	V
Input Current "L"	lil	ENA	VDD = 5.0V Vin = 0V	-5	-	5	μA
Input Current "H"	lih	ENA	VDD = 5.0V Vin = 5.0V	25	50	100	μA
Input "L" detection Voltage	Vil	IN1, IN2, IN3, IN4, ENA, SEL, CRESET	VDD=3.0 to 5.5V	0	-	0.3x VDD	V
Input "H" detection Voltage	Vih			0.7x VDD	-	VDD	V
Hysteresis	Vh			VDD=4.5 to 5.5V	0.25	0.5	0.7
Input Current "L"	lil	IN1, IN2, IN3, IN4, SEL	VDD = 5.0V Vin = 0V	-100	-50	-25	μA
Input Current "H"	lih	IN1, IN2, IN3, IN4, SEL	VDD = 5.0V Vin = 5.0V	-5	-	5	μA

Note 1: About the current, it defines IC_Sink as (+) and IC_Source as (-).

7.3. Charge Pump

CHARACTERISTIC	SYMBOL	PIN	CONDITION	MIN	TYP.	MAX	UNIT
Output Voltage	Vcp1	PCCO	VB=6V to 8V Cpcc=0.1μF Rpcc=10Ω Rpcco=2.5kΩ Cpcco1=10μF Cpcco2=1μF	SO+7.5	SO+8.8	SO+13	V
	Vcp2		VB=8V to 21V Cpcc=0.1μF Rpcc=10Ω Rpcco=2.5kΩ Cpcco1=10μF Cpcco2=1μF	SO+10	SO+12	SO+14.0 (Note 2)	V
	Vcp3		VB=5V to 6V Cpcc=0.1μF Rpcc=10Ω Rpcco=2.5kΩ Cpcco1=10μF Cpcco2=1μF	SO+5.8	SO+7.1	SO+10.1	V
	Vcp4		VB=4V to 5V Cpcc=0.1μF Rpcc=10Ω Rpcco=2.5kΩ Cpcco1=10μF Cpcco2=1μF	SO+4.0	-	-	V
Active Clamp Voltage	Vcpclh	PCCO	-	31	36	40	V
	Vcpcll			30.5	35.5	39.5	V

Note 1: About the current, it defines IC_Sink as (+) and IC_Source as (-).

Note 2: When VB=21V, SO=5V in Vcp2, the maximum specification becomes SO+15.4V.

Because the circuit configuration makes PCCO voltage = VB-3VF, in case VB-3VF > (SO+12V)

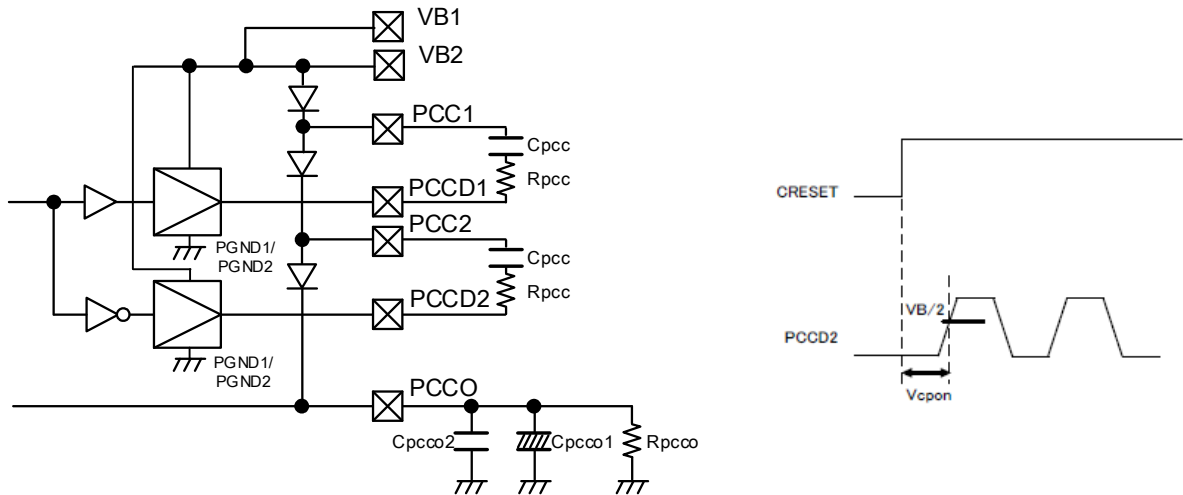

Note 3: Some of the functional blocks, circuits, or constants in the block diagram may be omitted or simplified for explanatory purpose.

7.4. Pre-Driver

CHARACTERISTIC	SYMBOL	PIN	CONDITION	MIN	TYP.	MAX	UNIT
Output Voltage	Voh1	HO1, HO2	Clod=10nF, Roh=100Ω	Vcp-1	-	Vcp*	V
	Vol1			-	-	0.5	V
	Voh2	LO1, LO2	Clod=10nF, Rol=20Ω	7	12	14	V
	Vol2			-	-	0.5	V
Output Resistance	Ronh1	HO1,HO2,	Pre-driver High Side Ron (Calculate the resistance from the voltage difference between in case Iload=10mA and 50mA)	-	4	10	Ω
	Ronh2	LO1, LO2	Pre-driver High Side Ron (Calculate the resistance from the voltage difference between in case Iload=10mA and 50mA)	-	10	20	Ω
	Ronl	HO1,HO2, LO1, LO2	Pre-driver Low Side Ron (Calculate the resistance from the voltage difference between in case Iload=10mA and 50mA)	-	4	10	Ω
Turn on time	Ton1A	HO1, HO2	VB=5 to 6V, Roh=100Ω Rol=20Ω, Clod=10nF, VB+1V→VB+6V	10	-	70	ns
	Ton1		VB=6 to 21V, Roh=100Ω Rol=20Ω, Clod=10nF, VB+1V→VB+7V				
Turn off time	Toff1A		VB=5 to 6V, Roh=100Ω Rol=20Ω, Clod=10nF, VB+6V→VB+1V	1	-	50	ns
	Toff1		VB=6 to 21V, Roh=100Ω Rol=20Ω, Clod=10nF, VB+7V→VB+1V				
Turn on time	Ton2	LO1, LO2	VB=5 to 21V, Roh=100Ω Rol=20Ω, Clod=10nF, 1V→7V	30	-	300	ns
Turn off time	Toff2		VB=5 to 21V, Roh=100Ω Rol=20Ω, Clod=10nF, 7V→1V	1	-	50	ns
Propagation Delay time of Input	Tp1	HO1,HO2, LO1, LO2	The time until driver output changes as much as 1V, in case IN falls. Roh=100Ω, Rol=20Ω Clod=10nF	100	-	500	ns
	Tp2		The time until driver output changes as much as 1V, in case IN raises. Roh=100Ω, Rol=20Ω Clod=10nF	50	-	350	ns
Time tolerant of Input propagation delay time	Tp_diff	HO1,HO2, LO1, LO2	Time difference between HO1 propagation delay (rising edge) and LO1 propagation delay (falling edge) Tp-on(HO1) – Tp-off(LO1)	20	120	220	ns
			Time difference between HO2 propagation delay (rising edge) and LO2 propagation delay (falling edge) Tp-on(HO2) – Tp-off(LO2)	20	120	220	ns
			Time difference between HO1 propagation delay (falling edge) and LO1 propagation delay (rising edge) Tp-off(HO1) – Tp-on(LO1)	20	120	220	ns
			Time difference between HO2 propagation delay (falling edge) and LO2 propagation delay (rising edge) Tp-off(HO2) – Tp-on(LO2)	20	120	220	ns

Dead time	Tdt	HO1, HO2, LO1, LO2	-	0.25	0.5	0.75	μs
Pre-Driver operation start time	Tst	SEL, ENA	The time interval from changing SEL, ENA=Low⇔ High to change 1V of the pre-driver output	50	250	500	ns

*Vcp: Charge pump voltage

Note 1: About the current, it defines IC_Sink as (+) and IC_Source as (-).

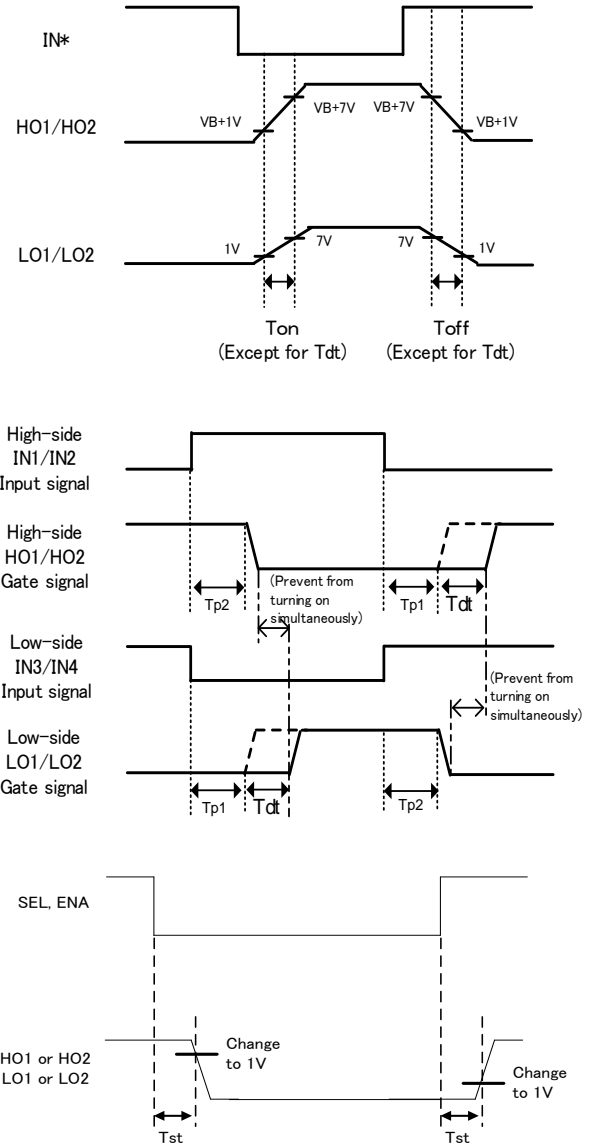
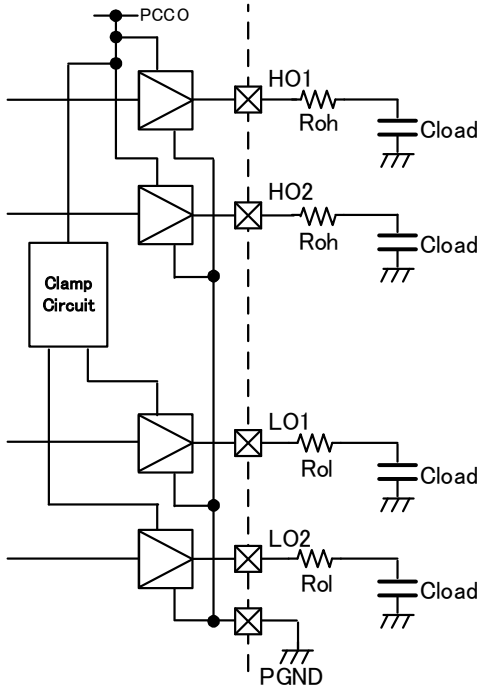

Note 1: Some of the functional blocks, circuits, or constants in the block diagram may be omitted or simplified for explanatory purpose.

Note 2: The timing charts is to describe the function and operation of IC. Therefore it is different from the actual wave form of the IC.

7.5. Current Detection Circuit

CHARACTERISTIC	SYMBOL	PIN	CONDITION	MIN	TYP.	MAX	UNIT
Common mode Input Voltage Range	V _{in}	AMPMP1, AMPMP2, AMPMP1, AMPMP2	Voltage Follower, no-load, Input voltage range which can operate AMP	0.1	-	VCC5A - 0.1	V
Input Bias Current Difference	I _{ib}	AMPMP1, AMPMP2, AMPMP1, AMPMP2	Voltage Follower, no-load, V _{in} =0.1V to VCC5A-0.1V *Current difference between AMPMP1 and AMPMP2. Current difference between AMPMP1 and AMPMP2.	-0.3	-	0.3	μA
Input Offset Voltage	V _{io1}	AMPMP1, AMPMP1, AMPMP2, AMPMP2	Voltage Follower, no-load V _{in} = 0.1V to VCC5A-0.1V	-8	-	8	mV
Slew rate	T _{th1}	CS1, CS2	Voltage Follower, no-load V _{in} = 0.3V to VCC5A-0.3V	3	6	10.5	V/μs
Maximum Output Voltage	V _{oh1}	CS1, CS2	Voltage Follower I _{load} =±500μA	VCC5A - 0.1	-	VCC5A	V
Minimum Output Voltage	V _{ol1}	CS1, CS2	Voltage Follower I _{load} =±500μA	0	-	0.1	V

Note 1: About the current, it defines I_{C_Sink} as (+) and I_{C_Source} as (-).

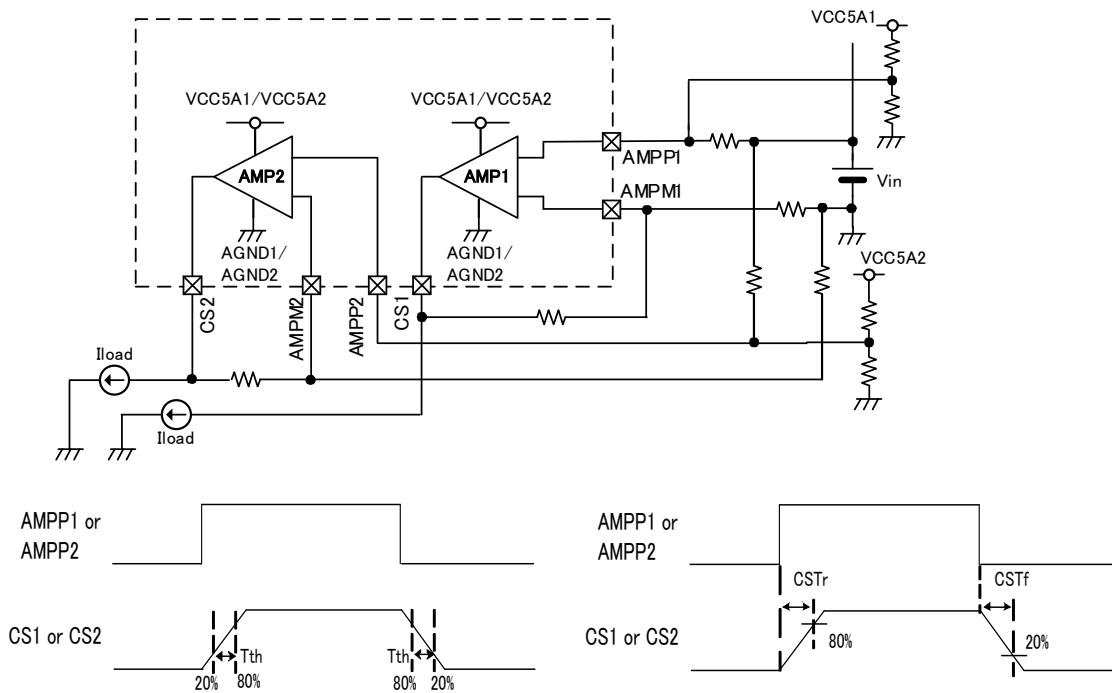

Note 1: Some of the functional blocks, circuits, or constants in the block diagram may be omitted or simplified for explanatory purpose.

Note 2: The timing charts is to describe the function and operation of IC. Therefore it is different from the actual wave form of the IC.

7.6. Motor Drive Direction Detection Circuit

CHARACTERISTIC	SYMBOL	PIN	CONDITION	MIN	TYP.	MAX	UNIT
Input "H" detection Voltage	Vih	DR1, DR2	RDR=1kΩ	0.50x SO	0.55x SO	0.60x SO	V
Input "L" detection Voltage	Vil	DR1, DR2	RDR=1kΩ	0.40x SO	0.45x SO	0.50x SO	V
Hysteresis	Vhys	DR1, DR2	Vhys = Vih-Vil	-	0.1x SO	-	V
Output Voltage "H"	Voh	MR1, MR2	Iload = -1mA	0.8x VDD	-	VDD	V
Output Voltage "L"	Vol	MR1, MR2	Iload = 1mA	-	-	0.2x VDD	V
Detection delay time	Tmr_on	MR1, MR2	DR1,2=0.55xSO ⇒ MR1,2=0.8xVDD Iload = ±1mA RDR=1kΩ	0.1	0.6	2	μs
	Tmr_off	MR1, MR2	DR1,2=0.55xSO ⇒ MR1,2=0.2xVDD Iload = ±1mA RDR=1kΩ	0.1	0.6	2	μs
Common mode Input Voltage Range	Vin	DR1, DR2	Apply -2V by setting RDR1,2=1kΩ	-VF	-	SO	V
Internal Pull-down Resistance	DR_PR	DR1, DR2	-	1.4	2	2.6	MΩ

Note 1: Minimum voltage of Common mode Input Voltage Range is VF voltage of internal protection device.

Note 2: About the current, it defines IC_Sink as (+) and IC_Source as (-).

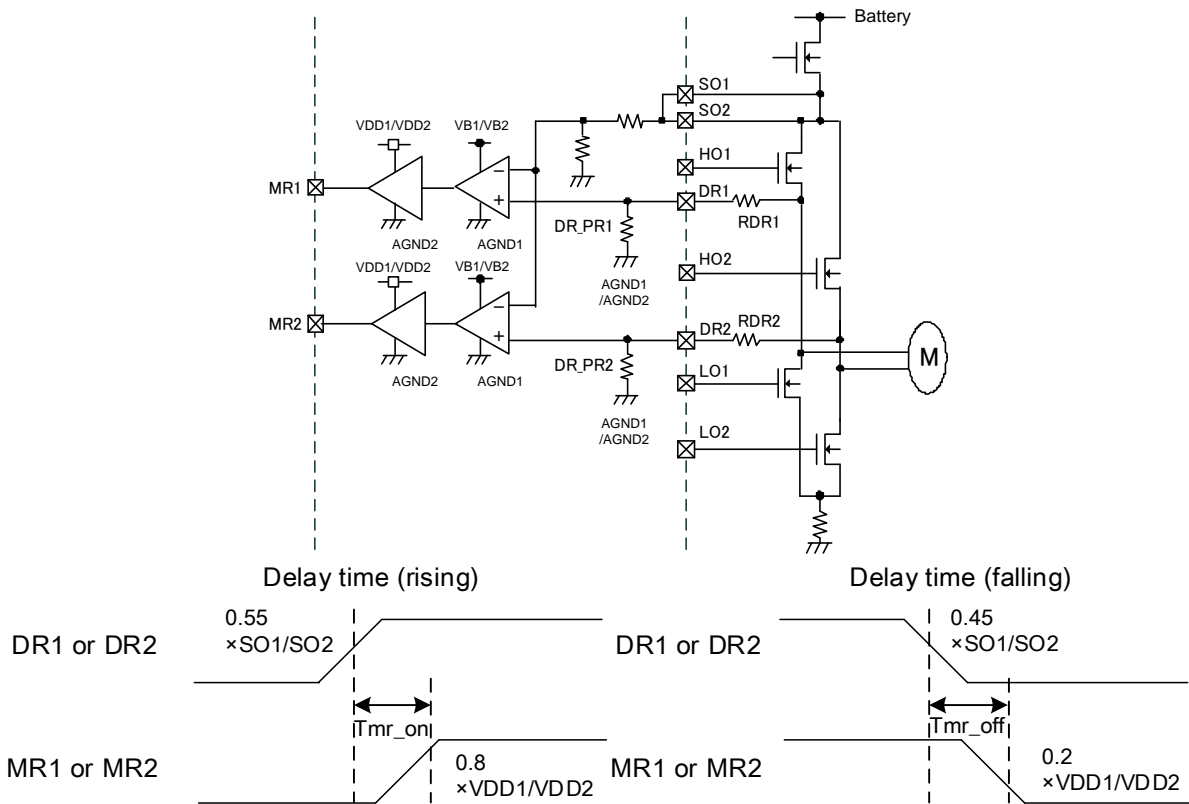

Note 3: The timing charts is to describe the function and operation of IC. Therefore it is different from the actual wave form of the IC.

7.7. Abnormality Detection Circuit

CHARACTERISTIC	SYMBOL	PIN	CONDITION	MIN	TYP.	MAX	UNIT
VB low voltage detection	Vcpll	VB	-	3.6	4.0	4.4	V
VB low voltage release	Vcplh			4.1	4.5	4.9	V
Hysteresis voltage of VB low voltage detection	Vcphys	VB	$V_{cphys} = V_{cplh} - V_{cpll}$	-	0.5	-	V
VDD low voltage detection	Vrstl	VDD	$V_{CC5A} \geq 4V$	2.7	2.8	2.9	V
VDD low voltage release	Vrsth			2.8	2.9	3.0	V
Hysteresis voltage of VDD low voltage detection	Vrsthys	VDD	$V_{CC5A} \geq 4V$ $V_{rsthys} = V_{rsth} - V_{rstl}$	-	0.1	-	V
Over Temperature detection	Tsdh	-	-	150	170	190	°C
Over Temperature release	Tsdl	-	-	140	160	180	°C
Hysteresis temperature of over Temperature detection	Tsdhys	-	$Tsdhys = Tsdh - Tsdl$	-	10	-	°C
Short detection Filtering time	Tsf	IN5	IN5=300kΩ	2.5	4	5.5	μs
		IN5	IN5=430kΩ	3.75	6	8.25	μs
		IN5	IN5=560kΩ	4.5	7.5	11	μs
PD voltage range	Vpd	PD1,PD2	VB=5 to 18V	0.5	-	2	V
Short detection error	Vsh_diff	PD1,PD2	VB=5 to 18V, PD=0.5 to 2V, RDR=1kΩ	-50	-	50	mV
Short detection delay time	Tsh	HO1, HO2, LO1, LO2	VB=5 to 18V, Time interval from DR rising to Pre-Driver Off (20%) (Cload=10nF, Rload=100Ω) *Filtering time is not included	0.1	0.6	3	μs
	Tsh2	DG1, DG2	VB=5 to 18V, Time interval from DR rising to switching between DR1 and DR2. *Filtering time is not included	0.01	0.6	2	μs
Short detection release ENA Low width time	Tena1	ENA	VB=5 to 18V	10	-	-	μs
Short detection release Pre-Driver operation start time	Tena2	ENA	VB=5 to 18V The time interval from changing ENA=Low→High to change 1V of the pre-driver output	-	-	1	μs

*Please use the resistance range of IN5 from 300kΩ to 2MΩ

Note 1 : In case $18 < SO \leq 21V$, due to the reverse output error of the comparator (COMP3/COMP4) at high-side, the error logic may have the reverse output error, too.

Note 2: About the current, it defines IC_Sink as (+) and IC_Source as (-).

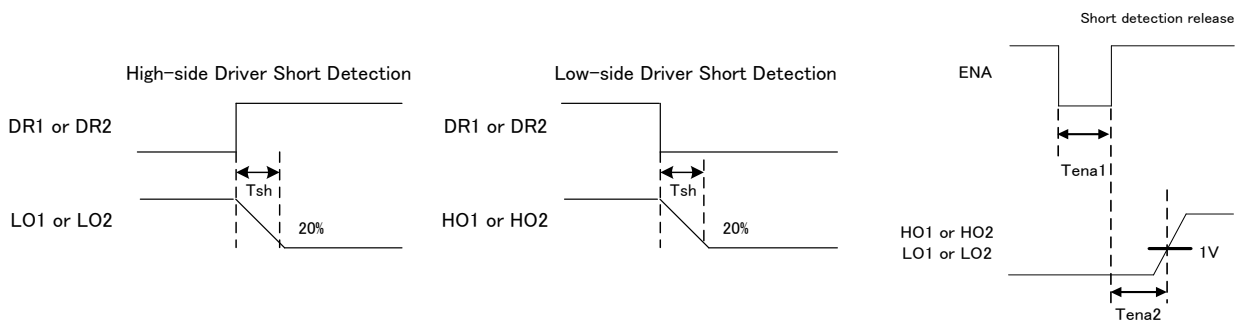

Note 3: The timing charts is to describe the function and operation of IC. Therefore it is different from the actual wave form of the IC.

8. Timing Chart

- SEL = Low (When it detects Short Detection and VB Low voltage detection, Pre-Driver becomes OFF)

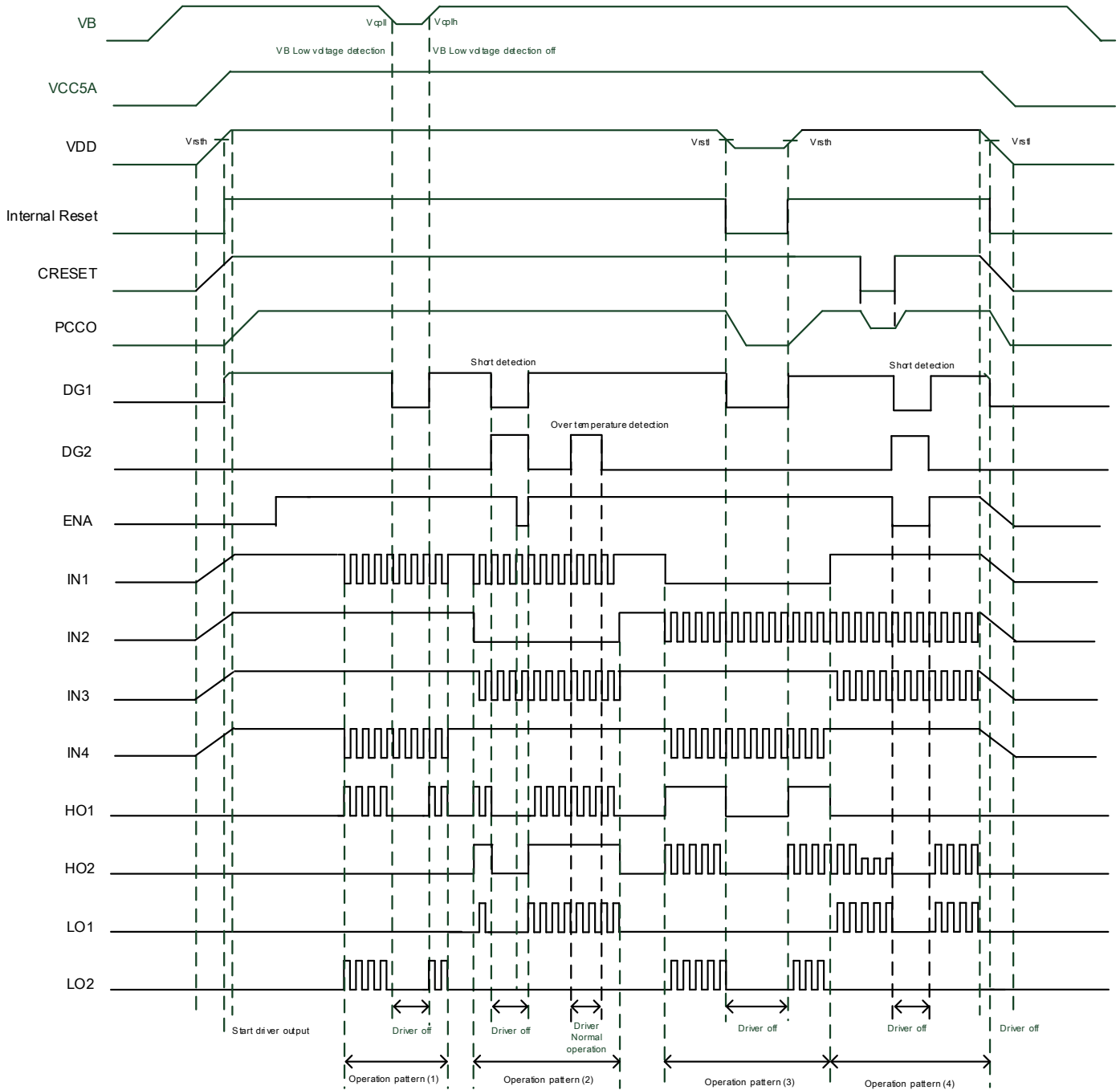

Note 1 : Please turn on VCC5A before VDD, in case it uses without short between VCC5A and VDD.

Note 2: The timing charts is to describe the function and operation of IC. Therefore it is different from the actual wave form of the IC.

*Driver operation pattern of above timing chart is as follow.

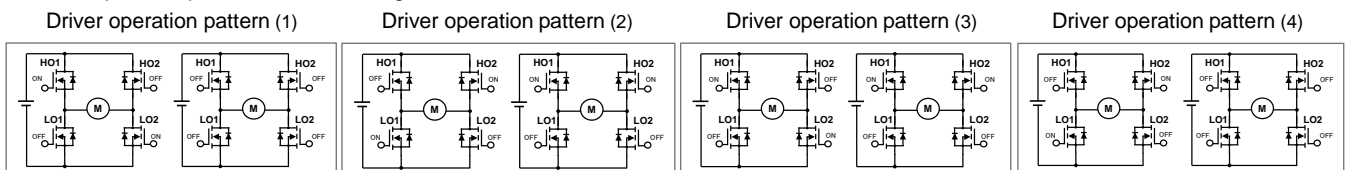

• SEL = High (When it detects Short Detection and VB Low voltage detection, Pre-Driver operates normally.)

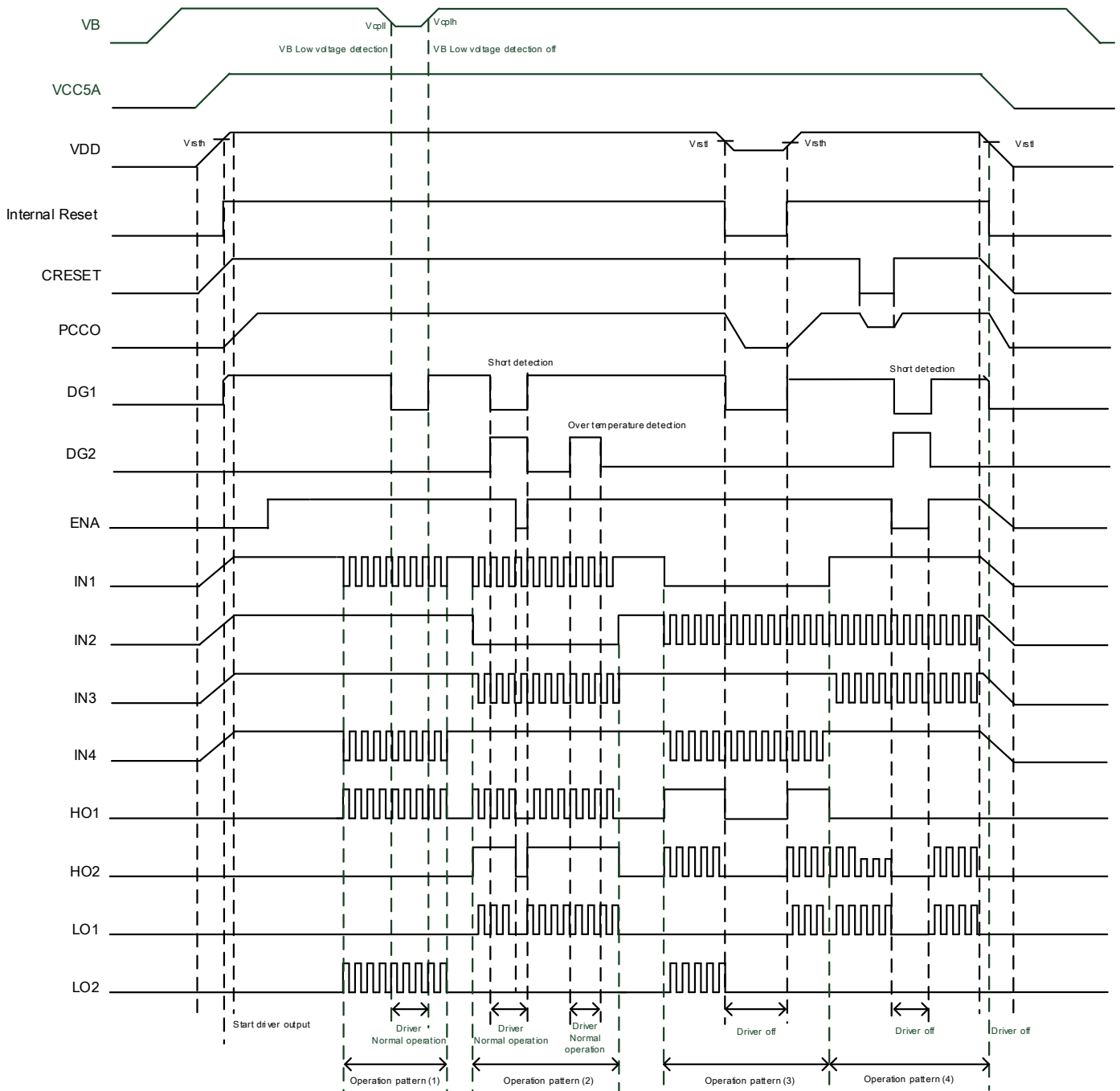

Note 1 : Please turn on VCC5A before VDD, in case it uses without short between VCC5A and VDD.

Note 2: The timing charts is to describe the function and operation of IC. Therefore it is different from the actual wave form of the IC.

*Driver operation pattern of above timing chart is as follow.

Driver operation pattern (1)

Driver operation pattern (2)

Driver operation pattern (3)

Driver operation pattern (4)

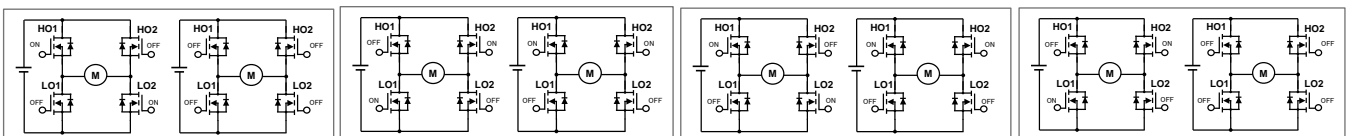

9. Reference Circuit Diagram

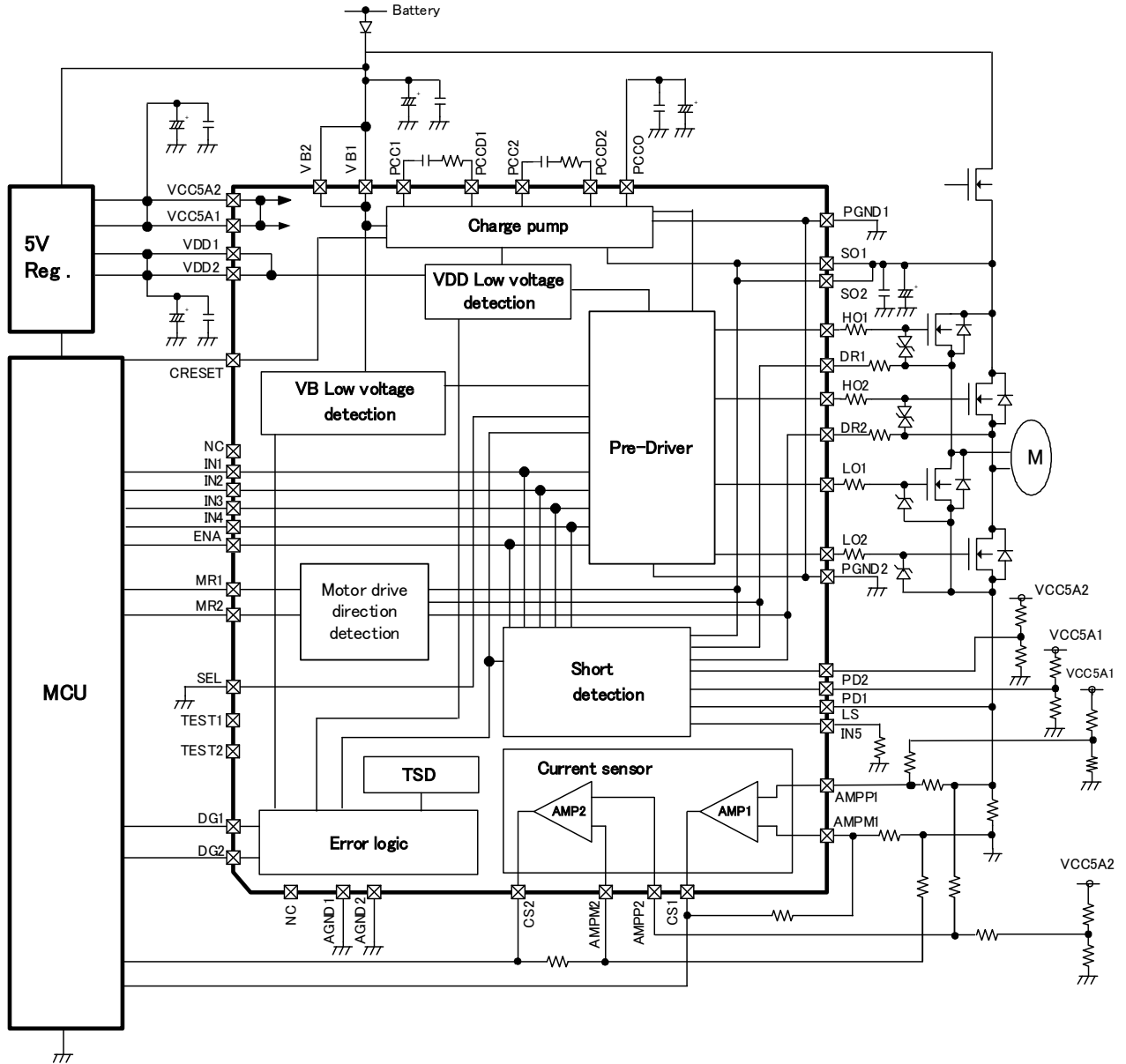

Note 1 : Some of the functional blocks, circuits, or constants in the block diagram may be omitted or simplified for explanatory purpose.

Note 2 : The equivalent circuit diagrams may be simplified or some parts of them may be omitted for explanatory purpose.

Note 3 : Timing charts may be simplified for explanatory purpose.

Note 4 : Install the product correctly. Otherwise, it may result in break down, damage and/or deterioration to the product or equipment.

Note 5 : The application circuits shown in this document are provided for reference purposes only. Especially, a thorough evaluation is required on the phase of mass production design. Providing these application circuit examples does not grant any license for industrial property rights.

10. PACKAGE

LQFP48-P-0707-0.50C

Unit: mm

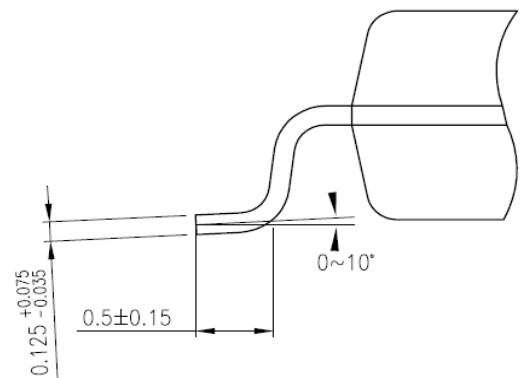
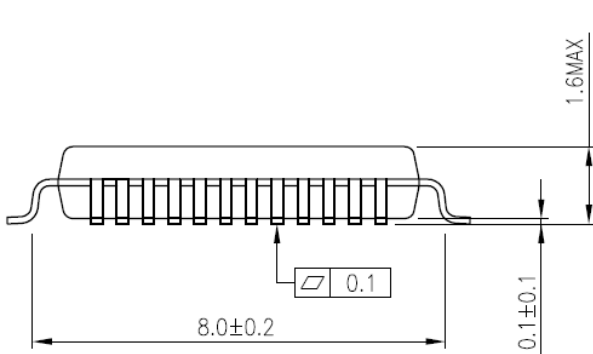
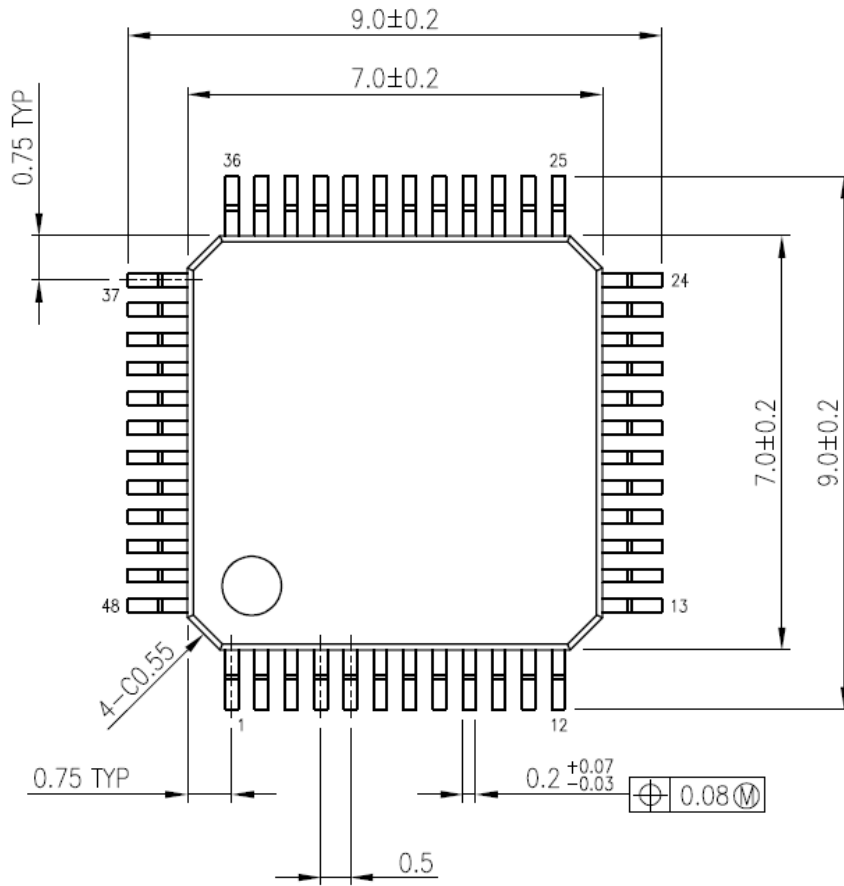

Weight: 0.186g (typ.)

RESTRICTIONS ON PRODUCT USE

Toshiba Corporation and its subsidiaries and affiliates are collectively referred to as "TOSHIBA". Hardware, software and systems described in this document are collectively referred to as "Product".

- TOSHIBA reserves the right to make changes to the information in this document and related Product without notice.
- This document and any information herein may not be reproduced without prior written permission from TOSHIBA. Even with TOSHIBA's written permission, reproduction is permissible only if reproduction is without alteration/omission.
- Though TOSHIBA works continually to improve Product's quality and reliability, Product can malfunction or fail. Customers are responsible for complying with safety standards and for providing adequate designs and safeguards for their hardware, software and systems which minimize risk and avoid situations in which a malfunction or failure of Product could cause loss of human life, bodily injury or damage to property, including data loss or corruption. Before customers use the Product, create designs including the Product, or incorporate the Product into their own applications, customers must also refer to and comply with (a) the latest versions of all relevant TOSHIBA information, including without limitation, this document, the specifications, the data sheets and application notes for Product and the precautions and conditions set forth in the "TOSHIBA Semiconductor Reliability Handbook" and (b) the instructions for the application with which the Product will be used with or for. Customers are solely responsible for all aspects of their own product design or applications, including but not limited to (a) determining the appropriateness of the use of this Product in such design or applications; (b) evaluating and determining the applicability of any information contained in this document, or in charts, diagrams, programs, algorithms, sample application circuits, or any other referenced documents; and (c) validating all operating parameters for such designs and applications. **TOSHIBA ASSUMES NO LIABILITY FOR CUSTOMERS' PRODUCT DESIGN OR APPLICATIONS.**
- **PRODUCT IS NEITHER INTENDED NOR WARRANTED FOR USE IN EQUIPMENTS OR SYSTEMS THAT REQUIRE EXTRAORDINARILY HIGH LEVELS OF QUALITY AND/OR RELIABILITY, AND/OR A MALFUNCTION OR FAILURE OF WHICH MAY CAUSE LOSS OF HUMAN LIFE, BODILY INJURY, SERIOUS PROPERTY DAMAGE AND/OR SERIOUS PUBLIC IMPACT ("UNINTENDED USE").** Except for specific applications as expressly stated in this document, Unintended Use includes, without limitation, equipment used in nuclear facilities, equipment used in the aerospace industry, Class 3 medical devices, and military vehicles and munitions. **IF YOU USE PRODUCT FOR UNINTENDED USE, TOSHIBA ASSUMES NO LIABILITY FOR PRODUCT.** For details, please contact your TOSHIBA sales representative or contact us via our website.
- Do not disassemble, analyze, reverse-engineer, alter, modify, translate or copy Product, whether in whole or in part.
- Product shall not be used for or incorporated into any products or systems whose manufacture, use, or sale is prohibited under any applicable laws or regulations.
- The information contained herein is presented only as guidance for Product use. No responsibility is assumed by TOSHIBA for any infringement of patents or any other intellectual property rights of third parties that may result from the use of Product. No license to any intellectual property right is granted by this document, whether express or implied, by estoppel or otherwise.
- **ABSENT A WRITTEN SIGNED AGREEMENT, EXCEPT AS PROVIDED IN THE RELEVANT TERMS AND CONDITIONS OF SALE FOR PRODUCT, AND TO THE MAXIMUM EXTENT ALLOWABLE BY LAW, TOSHIBA (1) ASSUMES NO LIABILITY WHATSOEVER, INCLUDING WITHOUT LIMITATION, INDIRECT, CONSEQUENTIAL, SPECIAL, OR INCIDENTAL DAMAGES OR LOSS, INCLUDING WITHOUT LIMITATION, LOSS OF PROFITS, LOSS OF OPPORTUNITIES, BUSINESS INTERRUPTION AND LOSS OF DATA, AND (2) DISCLAIMS ANY AND ALL EXPRESS OR IMPLIED WARRANTIES AND CONDITIONS RELATED TO SALE, USE OF PRODUCT, OR INFORMATION, INCLUDING WARRANTIES OR CONDITIONS OF MERCHANTABILITY, FITNESS FOR A PARTICULAR PURPOSE, ACCURACY OF INFORMATION, OR NONINFRINGEMENT.**
- Do not use or otherwise make available Product or related software or technology for any military purposes, including without limitation, for the design, development, use, stockpiling or manufacturing of nuclear, chemical, or biological weapons or missile technology products (mass destruction weapons). Product and related software and technology may be controlled under the applicable export laws and regulations including, without limitation, the Japanese Foreign Exchange and Foreign Trade Law and the U.S. Export Administration Regulations. Export and re-export of Product or related software or technology are strictly prohibited except in compliance with all applicable export laws and regulations.
- Please contact your TOSHIBA sales representative for details as to environmental matters such as the RoHS compatibility of Product. Please use Product in compliance with all applicable laws and regulations that regulate the inclusion or use of controlled substances, including without limitation, the EU RoHS Directive. **TOSHIBA ASSUMES NO LIABILITY FOR DAMAGES OR LOSSES OCCURRING AS A RESULT OF NONCOMPLIANCE WITH APPLICABLE LAWS AND REGULATIONS.**

TOSHIBA ELECTRONIC DEVICES & STORAGE CORPORATION

<https://toshiba.semicon-storage.com/>