

**32-bit RISC Microcontroller**

**TXZ Family**

**Reference Manual**

**Voltage Detection Circuit**

**(LVD-B)**

**Revision 2.1**

---

**2018-07**

**TOSHIBA ELECTRONIC DEVICES & STORAGE CORPORATION**

## Contents

Preface .....	4
Related document.....	4
Conventions .....	5
Terms and Abbreviations .....	7
1. Outline .....	8
2. Configuration.....	8
3. Details of a function and operation .....	9
3.1. Setting.....	9
3.2. Change of a setup.....	9
3.3. Detection/release timing .....	10
4. Register explanation .....	12
4.1. Register list .....	12
4.2. Details of a register .....	12
4.2.1. [LVDCR] (LVD control register) .....	12
5. Revision history.....	13
RESTRICTIONS ON PRODUCT USE.....	14

## List of Figures

Figure 2.1	The Block Diagrams of LVD .....	8
Figure 3.1	LVD release timing.....	10
Figure 3.2	LVD detection, Release timing .....	11
Figure 3.3	LVD detection minimum pulse width .....	11

## List of Tables

Table 2.1	List of Signals.....	8
Table 5.1	Revision history.....	13

## Preface

### Related document

Document name
Product Information
Power Supply and Reset Operation
Exception

## Conventions

- Numeric formats follow the rules as shown below:
  - Hexadecimal: 0xABC
  - Decimal: 123 or 0d123 – Only when it needs to be explicitly shown that they are decimal numbers.
  - Binary: 0b111 – It is possible to omit the "0b" when the number of bit can be distinctly understood from a sentence.
- "\_N" is added to the end of signal names to indicate low active signals.
- It is called "assert" that a signal moves to its active level, "deassert" to its inactive level.
- When two or more signal names are referred, they are described like as [m: n].  
Example: S[3: 0] shows four signal names S3, S2, S1 and S0 together.
- The characters surrounded by [ ] defines the register.  
Example: [ABCD]
- "n" substitutes suffix number of two or more same kind of registers, fields, and bit names.  
Example: [XYZ1], [XYZ2], [XYZ3] → [XYZn]
- "x" substitutes suffix number or character of units and channels in the Register List.  
In case of unit, "x" means A, B, and C ...  
Example: [ADACR0], [ADBCR0], [ADCCR0] → [ADxCR0]  
In case of channel, "x" means 0, 1, and 2 ...  
Example: [T32A0RUNA], [T32A1RUNA], [T32A2RUNA] → [T32AxRUNA]
- The bit range of a register is written like as [m: n]  
Example: Bit[3: 0] expresses the range of bit 3 to 0.
- The configuration value of a register is expressed by either the hexadecimal number or the binary number.  
Example: [ABCD]<EFG> =0x01 (hexadecimal), [XYZn]<VW> =1 (binary)
- Word and Byte represent the following bit length.
  - Byte: 8 bits
  - Half word: 16 bits
  - Word: 32 bits
  - Double word: 64 bits
- Properties of each bit in a register are expressed as follows:
  - R: Read only
  - W: Write only
  - R/W: Read and Write are possible
- Unless otherwise specified, register access supports only word access.
- The register defined as reserved must not be rewritten. Moreover, do not use the read value.
- The value read from the bit having default value of "-" is unknown.
- When a register containing both of writable bits and read-only bits is written, read-only bits should be written with their default value, In the cases that default is "-", follow the definition of each register.
- Reserved bits of the Write-only register should be written with their default value.  
In the cases that default is "-", follow the definition of each register.
- Do not use read-modified-write processing to the register of a definition which is different by writing and read out.

\*\*\*\*\*  
Arm, Cortex and Thumb are registered trademarks of Arm Limited (or its subsidiaries) in the US  
and/or elsewhere. All rights reserved.  
\*\*\*\*\*



The Flash memory uses the Super Flash® technology under license from Silicon Storage Technology, Inc.  
Super Flash® is registered trademark of Silicon Storage Technology, Inc.

All other company names, product names, and service names mentioned herein may be trademarks of their respective companies.

## Terms and Abbreviations

Some of abbreviations used in this document are as follows:

INT	Interrupt
LVD	Voltage Detection Circuit
POR	Power On Reset Circuit

## 1. Outline

The main functions of a voltage detecting circuit (LVD) are as follows.

Function classification	Function	Functional Description	Remarks
Supply voltage detection function	Reset Output	It is reset generating below in setting detection voltage.	Either the reset output or an interrupt request output is chosen
	Interrupt request	An interrupt request is generated below in setting detection voltage.	
	Monitor	A monitor is possible as voltage detection status.	
	Detection voltage selection	The selection out of eight kinds is possible.	

## 2. Configuration

A voltage detection circuit consists of a reference voltage generation circuit, a detection voltage selection circuit, a Comparator, and a control register.

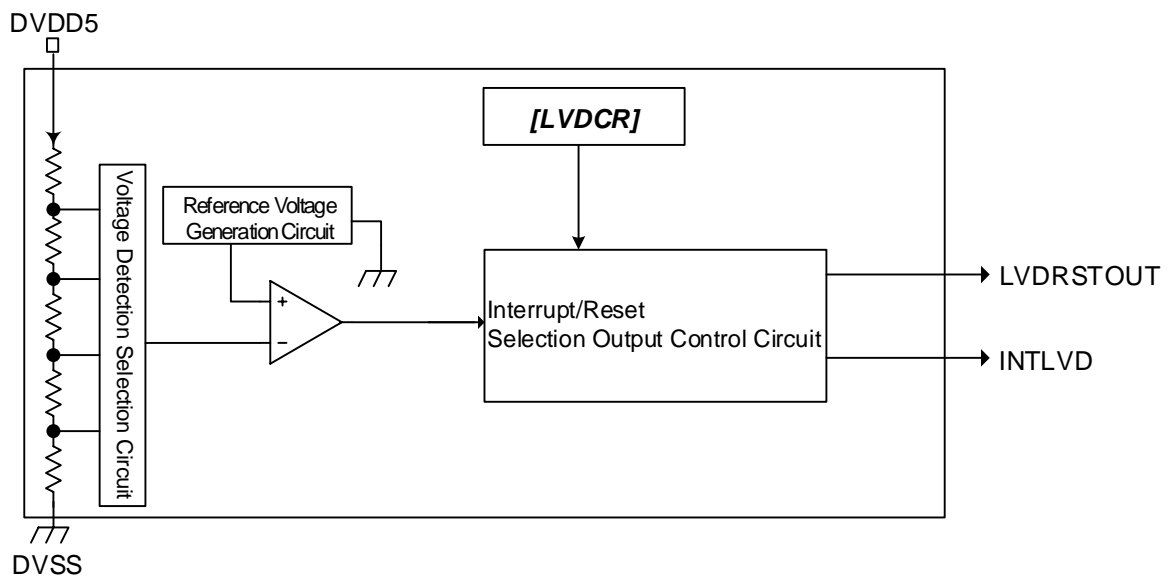

Figure 2.1 The Block Diagrams of LVD

Table 2.1 List of Signals

No	Symbol	Signal name	I/O	Related Reference manual
1	DVDD5	Power supply pin for detection	Input	Product Information
2	LVDRSTOUT	LVD reset Output	Output	Power Supply and Reset Operation
3	INTLVD	LVD interrupt request signal	Output	Exception



### 3. Details of a function and operation

A voltage detection circuit supervises the voltage of DVDD5.

The reference voltage which occurred in the reference voltage generating circuit is compared with the output of the detection voltage made from DVDD5. Detection voltage can be chosen.

According to a comparison result, interrupt/reset selection output control circuit outputs reset or interrupt.

At the power up, while the voltage of DVDD5 is lower than release voltage, reset (LVDRSTOUT) is outputted. Reset will be released if release voltage is exceeded.

#### 3.1. Setting

In the voltage detection circuit, the enable/disable operation is carried out by the *[LVDCR]<EN>*, the *[LVDCR]<LVL>* can select the detection voltage, the *[LVDCR]<SEL>* can select either LVDRSTOUT or INTLVD, and the *[LVDCR]<OUTEN>* can set the output control .

When *[LVDCR] <EN>* is set to "1" after selection of detection voltage, setting of LVDRSTOUT and interrupt selection, operation is enabled and detection operation starts.

If the voltage of DVDD5 becomes lower than detection voltage, either LVDRSTOUT selected by *[LVDCR]<SEL>* or INTLVD is outputted.

In addition, also where LVDRSTOUT/ INTLVD is forbidden by *[LVDCR]<OUTEN>*, a voltage condition can be monitored by *[LVDCR]<ST>*.

#### 3.2. Change of a setup

When changing of detection voltage, and a selection change of a LVDRSTOUT/ INTLVD interrupt Output, change a setup after setting *[LVDCR] <OUTEN>* to "0" and forbidding an Output.

The selection of the detection disable/enable by LVD motion control (*[LVDCR] <EN>*) should be set under the power control (*[LVDCR] <OUTEN>*) is set to "0".

Moreover, when *[LVDCR]<EN>* is set to "1", set *[LVDCR] <OUTEN>* to "1" after waiting 1 ms or more.

Change the detection voltage (*[LVDCR] <LVL [2:0]>*) after the output control (*[LVDCR] <OUTEN>*) is set to "0". And waiting 100 μs or more after changing *[LVDCR]<LVL [2:0]>*, set *[LVDCR]<OUTEN>* to "1".

### 3.3. Detection/release timing

Detection of the voltage detection circuit and releasing operation are shown in the following figure.

1) Power On

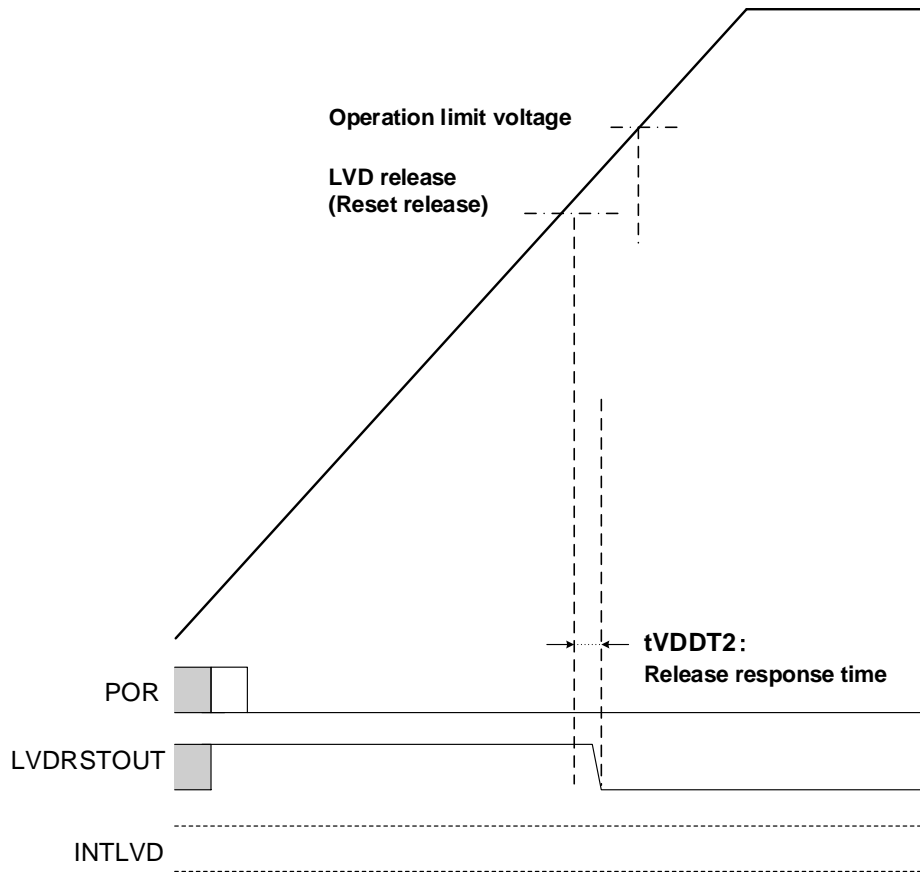

**Figure 3.1 LVD release timing**

2) LVD detection, Release timing

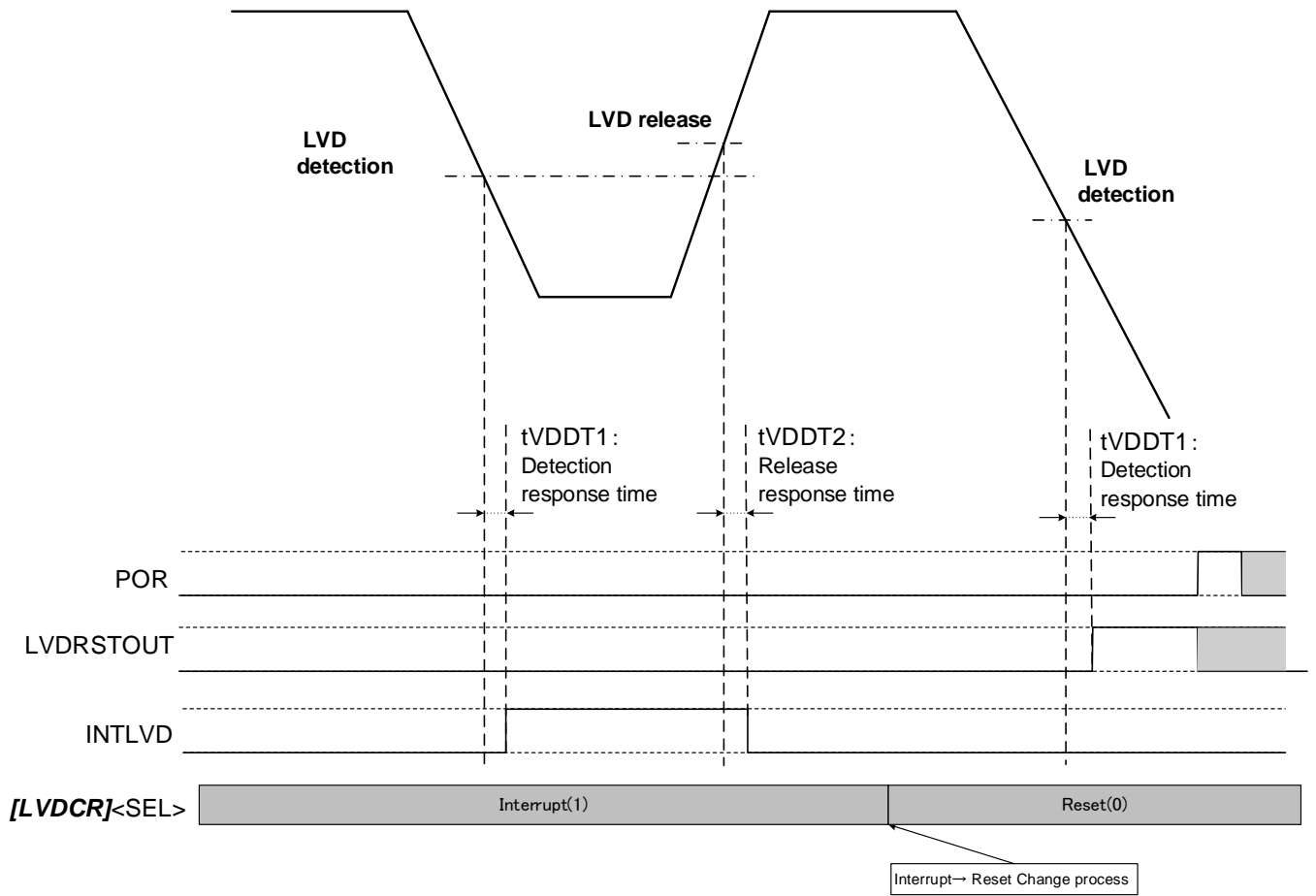

Figure 3.2 LVD detection, Release timing

3) LVD detection minimum pulse width

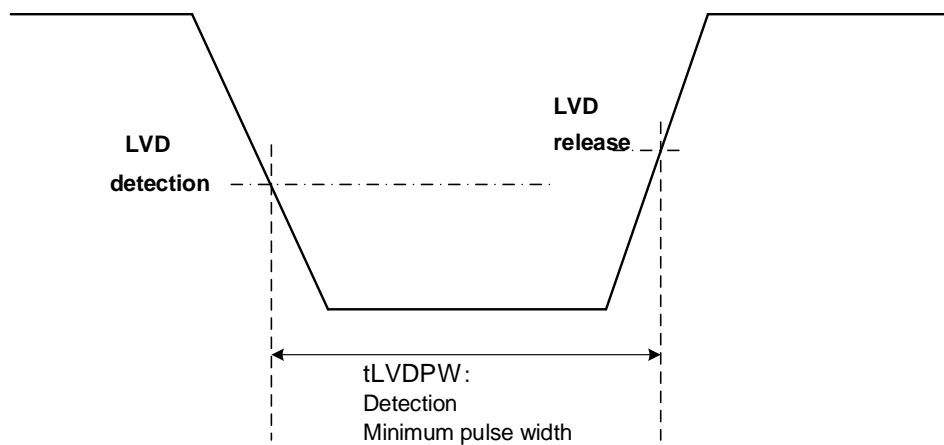

Figure 3.3 LVD detection minimum pulse width

## 4. Register explanation

### 4.1. Register list

The register and address of LVD are shown below.

Peripheral function		Channel/Unit	Base address
			TYPE 1
Voltage detection circuit	LVD	-	0x4003EC00

Register name		Address (Base+)
LVD control register	<b>[LVDCR]</b>	0x0000

Note: The **[LVDCR]** cannot be bit band accessed. Only byte access is possible.

### 4.2. Details of a register

#### 4.2.1. [LVDCR] (LVD control register)

Bit	Bit Symbol	After reset	Type	Function																		
7	ST	0	R	Voltage detection status (notes) 0: A supply voltage is more than detection voltage. 1: A supply voltage is below detection voltage.																		
6:4	LVL[2:0]	000	R/W	<table border="0"> <tr> <td>Detection voltage</td> <td>Release voltage</td> </tr> <tr> <td>000: 2.6V</td> <td>000: 2.65V</td> </tr> <tr> <td>001: 2.7V</td> <td>001: 2.75V</td> </tr> <tr> <td>010: 2.8V</td> <td>010: 2.85V</td> </tr> <tr> <td>011: 2.9V</td> <td>011: 2.95V</td> </tr> <tr> <td>100: 4.0V</td> <td>100: 4.05V</td> </tr> <tr> <td>101: 4.2V</td> <td>101: 4.25V</td> </tr> <tr> <td>110: 4.4V</td> <td>110: 4.45V</td> </tr> <tr> <td>111: 4.6V</td> <td>111: 4.65V</td> </tr> </table>	Detection voltage	Release voltage	000: 2.6V	000: 2.65V	001: 2.7V	001: 2.75V	010: 2.8V	010: 2.85V	011: 2.9V	011: 2.95V	100: 4.0V	100: 4.05V	101: 4.2V	101: 4.25V	110: 4.4V	110: 4.45V	111: 4.6V	111: 4.65V
Detection voltage	Release voltage																					
000: 2.6V	000: 2.65V																					
001: 2.7V	001: 2.75V																					
010: 2.8V	010: 2.85V																					
011: 2.9V	011: 2.95V																					
100: 4.0V	100: 4.05V																					
101: 4.2V	101: 4.25V																					
110: 4.4V	110: 4.45V																					
111: 4.6V	111: 4.65V																					
3	-	0	R	Read as "0"																		
2	SEL	0	R/W	Selection of RESET or INTLVD interrupt 0: RESET(LVDRSTOUT) 1: Interruption (INTLVD)																		
1	OUTEN	1	R/W	Output control of RESET/ INTLVD interrupt 0: Output disable 1: Output enable																		
0	EN	1	R/W	LVD operation control 0: Disable Detection 1: Enable Detection																		

Note: When reading **[LVDCR]<ST>**, read out of multiple times is performed. Check the read value becomes the same.

## 5. Revision history

**Table 5.1 Revision history**

Revision	Date	Description
1.0	2017-11-10	First Release
2.0	2018-02-20	2.Configuration : Correction Figure 2.1 : The pin name (DVSS) was added. 3. Details of a function and operation : Deleted Duplicate expression deleted. 3.3. Detection/release timing : Correction Corrected of Figure 3.2. Deleted "LVD detection Minimum pulse width" Added: <b>[LVDCR]&lt;SEL&gt;</b> Added : "3) LVD detection Minimum pulse width"
2.1	2018-07-30	Conventions Modified explanation of trademark 4.1.Register list Added "TYPE 1" to the base address of the table. 4.2.1. [LVDCR] (LVD control register) Deleted Bit 31: 8 in the table.

## RESTRICTIONS ON PRODUCT USE

Toshiba Corporation and its subsidiaries and affiliates are collectively referred to as "TOSHIBA". Hardware, software and systems described in this document are collectively referred to as "Product".

- TOSHIBA reserves the right to make changes to the information in this document and related Product without notice.
- This document and any information herein may not be reproduced without prior written permission from TOSHIBA. Even with TOSHIBA's written permission, reproduction is permissible only if reproduction is without alteration/omission.
- Though TOSHIBA works continually to improve Product's quality and reliability, Product can malfunction or fail. Customers are responsible for complying with safety standards and for providing adequate designs and safeguards for their hardware, software and systems which minimize risk and avoid situations in which a malfunction or failure of Product could cause loss of human life, bodily injury or damage to property, including data loss or corruption. Before customers use the Product, create designs including the Product, or incorporate the Product into their own applications, customers must also refer to and comply with (a) the latest versions of all relevant TOSHIBA information, including without limitation, this document, the specifications, the data sheets and application notes for Product and the precautions and conditions set forth in the "TOSHIBA Semiconductor Reliability Handbook" and (b) the instructions for the application with which the Product will be used with or for. Customers are solely responsible for all aspects of their own product design or applications, including but not limited to (a) determining the appropriateness of the use of this Product in such design or applications; (b) evaluating and determining the applicability of any information contained in this document, or in charts, diagrams, programs, algorithms, sample application circuits, or any other referenced documents; and (c) validating all operating parameters for such designs and applications. **TOSHIBA ASSUMES NO LIABILITY FOR CUSTOMERS' PRODUCT DESIGN OR APPLICATIONS.**
- **PRODUCT IS NEITHER INTENDED NOR WARRANTED FOR USE IN EQUIPMENTS OR SYSTEMS THAT REQUIRE EXTRAORDINARILY HIGH LEVELS OF QUALITY AND/OR RELIABILITY, AND/OR A MALFUNCTION OR FAILURE OF WHICH MAY CAUSE LOSS OF HUMAN LIFE, BODILY INJURY, SERIOUS PROPERTY DAMAGE AND/OR SERIOUS PUBLIC IMPACT ("UNINTENDED USE").** Except for specific applications as expressly stated in this document, Unintended Use includes, without limitation, equipment used in nuclear facilities, equipment used in the aerospace industry, medical equipment, equipment used for automobiles, trains, ships and other transportation, traffic signaling equipment, equipment used to control combustions or explosions, safety devices, elevators and escalators, devices related to electric power, and equipment used in finance-related fields. **IF YOU USE PRODUCT FOR UNINTENDED USE, TOSHIBA ASSUMES NO LIABILITY FOR PRODUCT.** For details, please contact your TOSHIBA sales representative.
- Do not disassemble, analyze, reverse-engineer, alter, modify, translate or copy Product, whether in whole or in part.
- Product shall not be used for or incorporated into any products or systems whose manufacture, use, or sale is prohibited under any applicable laws or regulations.
- The information contained herein is presented only as guidance for Product use. No responsibility is assumed by TOSHIBA for any infringement of patents or any other intellectual property rights of third parties that may result from the use of Product. No license to any intellectual property right is granted by this document, whether express or implied, by estoppel or otherwise.
- **ABSENT A WRITTEN SIGNED AGREEMENT, EXCEPT AS PROVIDED IN THE RELEVANT TERMS AND CONDITIONS OF SALE FOR PRODUCT, AND TO THE MAXIMUM EXTENT ALLOWABLE BY LAW, TOSHIBA (1) ASSUMES NO LIABILITY WHATSOEVER, INCLUDING WITHOUT LIMITATION, INDIRECT, CONSEQUENTIAL, SPECIAL, OR INCIDENTAL DAMAGES OR LOSS, INCLUDING WITHOUT LIMITATION, LOSS OF PROFITS, LOSS OF OPPORTUNITIES, BUSINESS INTERRUPTION AND LOSS OF DATA, AND (2) DISCLAIMS ANY AND ALL EXPRESS OR IMPLIED WARRANTIES AND CONDITIONS RELATED TO SALE, USE OF PRODUCT, OR INFORMATION, INCLUDING WARRANTIES OR CONDITIONS OF MERCHANTABILITY, FITNESS FOR A PARTICULAR PURPOSE, ACCURACY OF INFORMATION, OR NONINFRINGEMENT.**
- Do not use or otherwise make available Product or related software or technology for any military purposes, including without limitation, for the design, development, use, stockpiling or manufacturing of nuclear, chemical, or biological weapons or missile technology products (mass destruction weapons). Product and related software and technology may be controlled under the applicable export laws and regulations including, without limitation, the Japanese Foreign Exchange and Foreign Trade Law and the U.S. Export Administration Regulations. Export and re-export of Product or related software or technology are strictly prohibited except in compliance with all applicable export laws and regulations.
- Please contact your TOSHIBA sales representative for details as to environmental matters such as the RoHS compatibility of Product. Please use Product in compliance with all applicable laws and regulations that regulate the inclusion or use of controlled substances, including without limitation, the EU RoHS Directive. **TOSHIBA ASSUMES NO LIABILITY FOR DAMAGES OR LOSSES OCCURRING AS A RESULT OF NONCOMPLIANCE WITH APPLICABLE LAWS AND REGULATIONS.**