

TOSHIBA CMOS Integrated Circuit Silicon Monolithic

TB6575FNG

PWM Sensorless Controller for 3-Phase Full-Wave BLDC Motors

1. Description

The TB6575FNG provides sensorless commutation and PWM current control for 3-phase full-wave BLDC motors. It controls rotation speed by changing a PWM duty cycle by analog voltage.

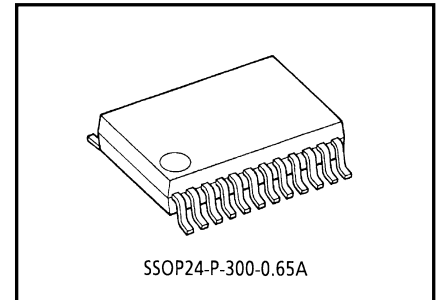

Weight: 0.14 g (Typ.)

2. Features

- 3-phase full-wave sensorless drive
- PWM chopper drive
- PWM duty cycle control by analog input
- 20-mA current sink capability on PWM output pins
- Overcurrent protection
- Forward/reverse rotation
- Lead angle control (7.5 ° and 15 °)
- Overlap commutation
- Rotation speed sensing signal
- DC excitation mode to improve startup characteristic
- DC excitation time and forced commutation time for startup operation can be changed.
- Forced commutation frequency can be selected. ($f_{\chi T}/(6 \times 2^{16})$, $f_{\chi T}/(6 \times 2^{17})$, $f_{\chi T}/(6 \times 2^{18})$)
- Output polarity switching (P-channel + N-channel, N-channel + N-channel)

3. Pin assignment

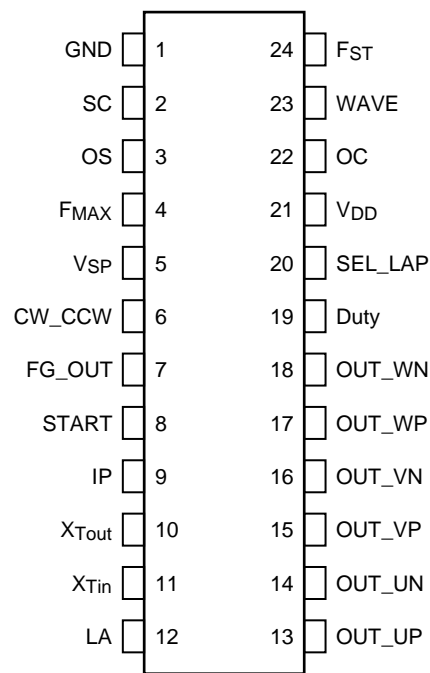

Figure 3 Pin Assignment

4. Block diagram

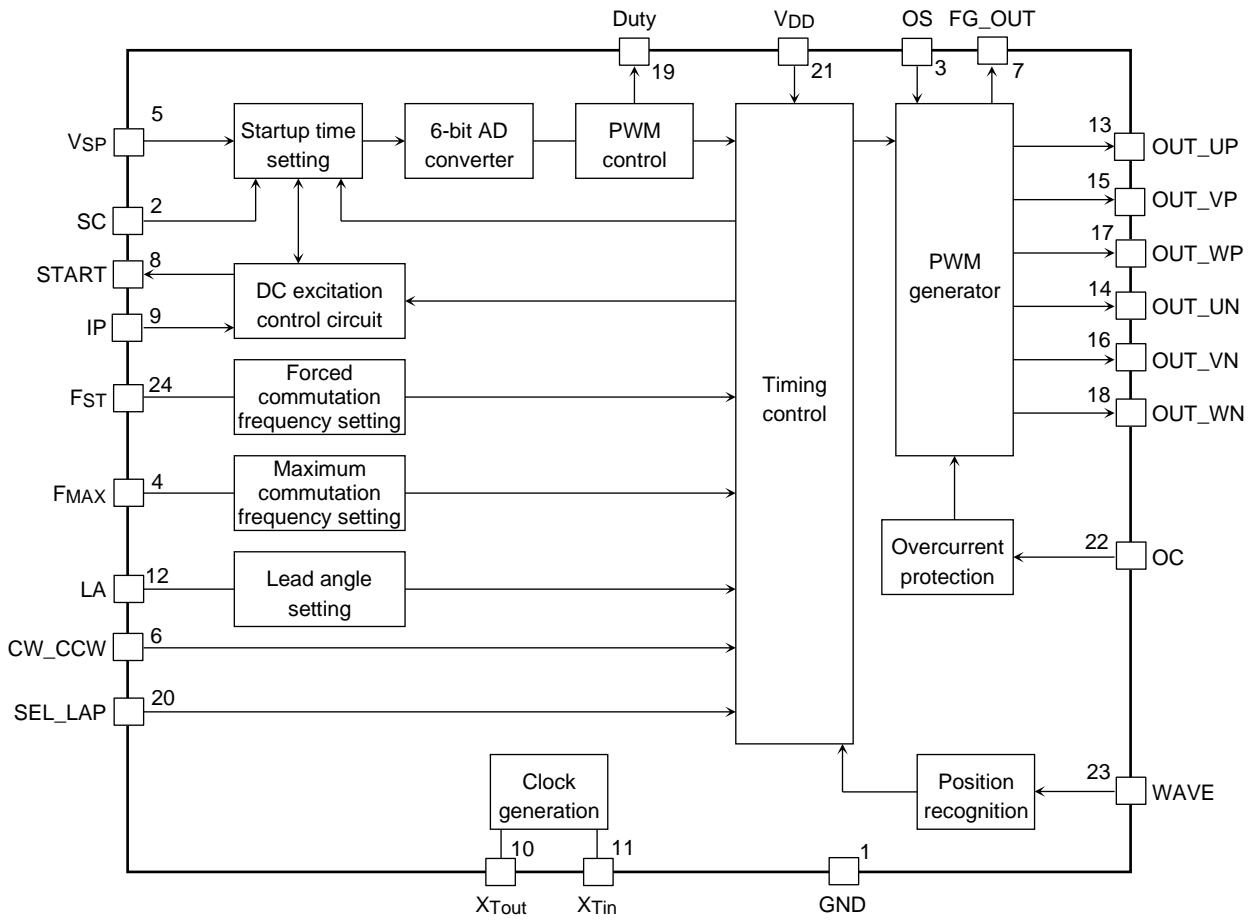

Figure 4 Block diagram

5. Pin Description

Table 5 Pin Description

Pin No.	Symbol	I/O	Description
1	GND	—	Ground pin
2	SC	I	Connection pin for a capacitor to set a startup commutation time and duty cycle ramp-up time
3	OS	I	Select the polarity of transistors. High or open: High-side transistor = P-channel (active low) Low-side transistor = N-channel (active High) Low: High-side transistor = N-channel (active High) Low-side transistor = N-channel (active High) The pin has a pull-up resistor.
4	FMAX	I	Set an upper limit of the maximum commutation frequency. <Fst=Low> FMAX =High or Open , Maximum commutation frequency $f_{MX} = f_{XT}/(6 \times 2^{11})$ FMAX =Low , Maximum commutation frequency $f_{MX} = f_{XT}/(6 \times 2^{12})$ <Fst=High or Middle> FMAX =High or Open , Maximum commutation frequency $f_{MX} = f_{XT}/(6 \times 2^8)$ FMAX =Low , Maximum commutation frequency $f_{MX} = f_{XT}/(6 \times 2^9)$ The pin has a pull-up resistor.
5	VSP	I	Duty cycle control input $0 \leq V_{SP} \leq V_{AD} (L)$: Output off $V_{AD} (L) \leq V_{SP} \leq V_{AD} (H)$: Set the PWM duty cycle according to the analog input. $V_{AD} (H) \leq V_{SP} \leq V_{DD}$: Duty cycle = 100 % (31/32) The pin has a pull-down resistor.
6	CW_CCW	I	Rotation direction input High: Reverse rotation (U → W → V) Low or open: Forward rotation (U → V → W) The pin has a pull-down resistor.
7	FG_OUT	O	Rotation speed sensing output The pin is low at startup or upon a detection of a fault. This pin drives three pulses per rotation (3 ppr) based on the back-EMF (electromotive force) sensing. (In the case of 4 pole motor, 6 pulse output per rotation.)
8	START	O	DC excitation time setting pins When $V_{sp} \geq 1 \text{ V}$ (typ.), the START pin goes low to start DC excitation. After the IP pin reaches $V_{DD}/2$, the TB6575FNG moves from DC excitation to forced commutation mode.
9	IP	I	
10	XTout	—	Connection pins for a ceramic oscillator These pins have a feedback resistor.
11	XTin	—	
12	LA	I	Lead angle control input LA = Low or open: Lead angle of 7.5 ° LA = high: Lead angle of 15 ° The pin has a pull-down resistor.
13	OUT_UP	O	PWM output signal for the high-side (positive-side) transistor driving motor phase U The PWM polarity can be specified by pin 3.
14	OUT_UN	O	PWM output signal for the low-side (negative-side) transistor driving motor phase U This signal is active high.
15	OUT_VP	O	PWM output signal for the high-side (positive-side) transistor driving motor phase V The PWM polarity can be specified by pin 3.
16	OUT_VN	O	PWM output signal for the low-side (negative-side) transistor driving motor phase V This signal is active high.
17	OUT_WP	O	PWM output signal for the high-side (positive-side) transistor driving motor phase W The PWM polarity can be specified by pin 3.
18	OUT_WN	O	PWM output signal for the low-side (negative-side) transistor driving motor phase W This signal is active high.
19	Duty	O	PWM output monitor pin This pin drives PWM output whose duty cycle corresponds to the Vsp input. It also reflects the information at the OC pin.

Pin No.	Symbol	I/O	Description
20	SEL_LAP	I	Overlap commutation select pin Low: Overlap commutation High, Open: 120° commutation The pin has a pull-up resistor.
21	VDD	—	5 V power supply pin
22	OC	I	Overcurrent detection input The all PWM output signals are stopped when $OC \geq 0.5$ (V). The pin has a pull-up resistor.
23	WAVE	I	Position sensing input Majority logic synthesis signal of 3-phase voltage is applied to this pin. The pin has a pull-up resistor.
24	FST	I	Forced commutation frequency select pin High or open: Forced commutation frequency $f_{ST} = f_{XT}/(6 \times 2^{16})$ Middle: Forced commutation frequency $f_{ST} = f_{XT}/(6 \times 2^{17})$ Low: Forced commutation frequency $f_{ST} = f_{XT}/(6 \times 2^{18})$ The pin has a pull-up resistor.

6. Functional Description

6.1. Sensorless drive

On receiving an analog voltage command input, the rotor is aligned to a known position in DC excitation mode, and then the rotation is started in forced commutation mode by applying a PWM signal to the motor. As the rotor moves, back-EMF is acquired.

When a signal indicating the polarity of each of the phase voltages including back-EMF is applied to the position signal input pin, automatic switching occurs from the forced commutation PWM signal to the natural commutation PWM signal (which is generated based on the back-EMF sensing) to drive a BLDC motor in sensorless mode.

6.2. Startup operation

When the motor is stationary, there is no back-EMF and the motor position is unknown. For this reason, the rotor is aligned to a known position in DC excitation mode and then the rotation is started in forced commutation mode. An external capacitor sets the times that the TB6575FNG stays in DC excitation and forced commutation modes. Those times vary depending on the motor type and motor loading. Thus, they must be adjusted experimentally.

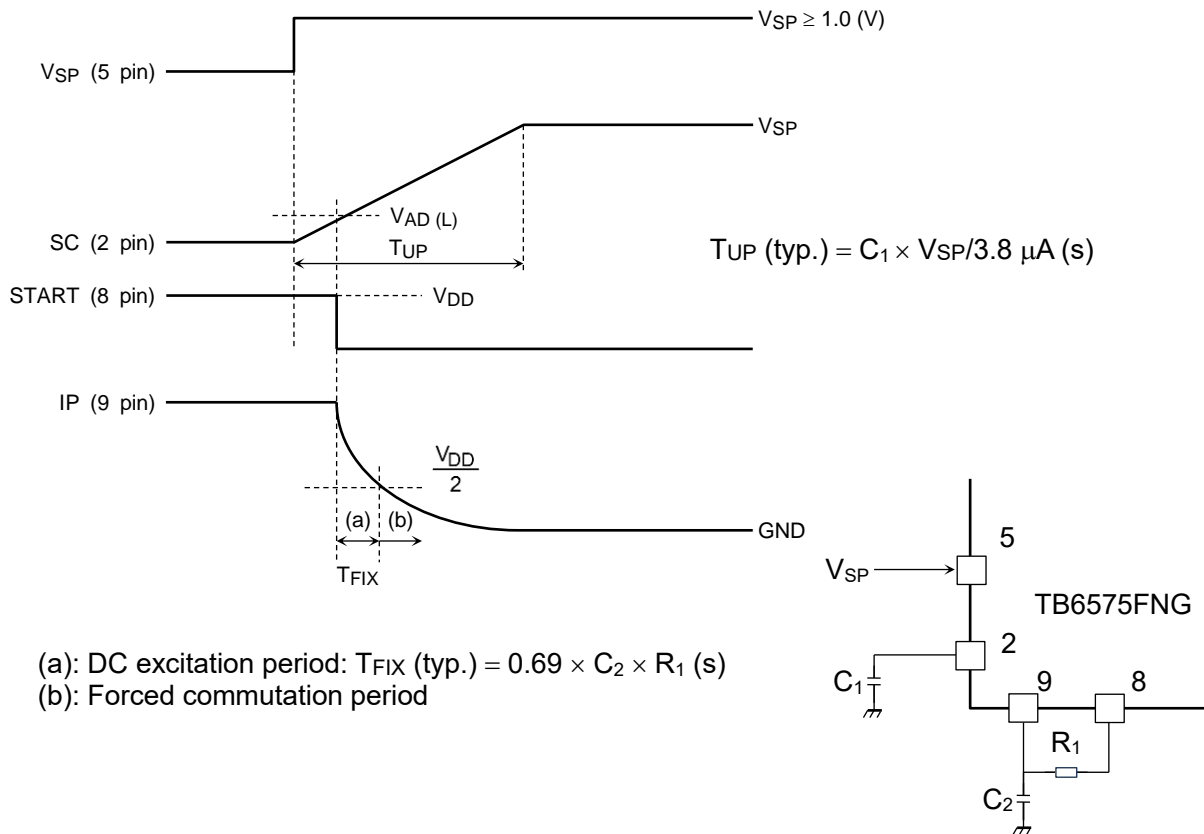

Figure 6.2 Startup operation

- The rotor is aligned to a known position in DC excitation mode for period (a), during which the IP pin voltage decreases to half V_{DD} level. The time constant for the period is determined by C_2 and R_1 . After that, switching occurs to forced commutation mode represented by (b).
- The duty cycles for DC excitation and forced commutation modes are determined according to the SC pin voltage.
- When the rotation frequency of the motor exceeds the forced commutation frequency, the motor switches to sensorless mode.
- The duty cycle for sensorless mode is determined by the SC pin voltage.

6.3. SC Signal Delay in Rotational Speed Control (VSP Follow-Up Property)

The VSP input is used to control the motor speed; the TB6575FNG allows the motor to start, stop and change the speed according to the voltage at VSP. However, the actual operation of the IC is determined by the voltage applied to the SC input. The voltage at the SC input equals the charging voltage of the capacitor C1, which depends on its charging and discharging times. This causes a delay in the rise and fall times of the SC voltage level. The following figure shows the SC delay that occurs when VSP changes between 1 V and 4 V.

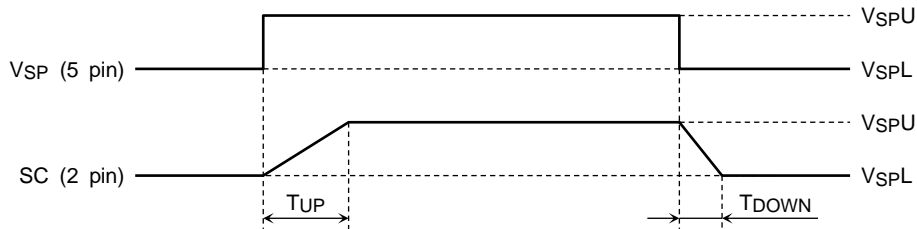

Figure 6.3 SC Signal Delay in Rotational Speed Control (VSP Follow-Up Property)

- Charging time of SC (for acceleration): $T_{UP} (typ.) = C1 \times (VSPU - VSPL) / 3.8 \mu A (s)$
- Discharging time of SC (for deceleration): $T_{DOWN} (typ.) = C1 \times (VSPU - VSPL) / 36 \mu A (s)$

Note: When the motor is stopped ($VSP < 1 V$), the capacitor C1 connected to the SC input discharges instantaneously. (C1 is discharged to GND through a 2 kΩ resistor.)

6.4. Forced commutation frequency

The forced commutation frequency for startup operation is set as follows. The optimal frequency varies depending on the motor type and motor loading. Thus, it must be adjusted experimentally.

- $F_{ST} = \text{High or Open:}$ Forced commutation frequency $f_{ST} = f_{XT} / (6 \times 2^{16})$
- $F_{ST} = \text{Middle:}$ Forced commutation frequency $f_{ST} = f_{XT} / (6 \times 2^{17})$
- $F_{ST} = \text{Low:}$ Forced commutation frequency $f_{ST} = f_{XT} / (6 \times 2^{18})$

f_{XT} : Ceramic oscillator frequency

6.5. PWM frequency

The PWM frequency is determined by an external oscillator.

$f_{PWM} = f_{XT} / 256$

f_{XT} : Ceramic oscillator frequency

The PWM frequency must be sufficiently high, compared with the electrical frequency of the motor and within the switching performance of the transistors.

OS = High or Open

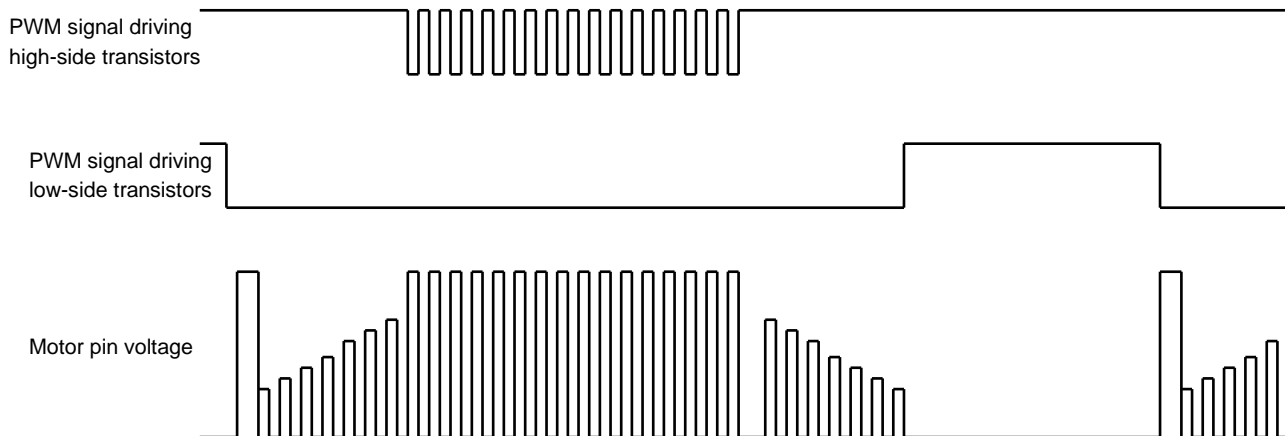

Figure 6.5 PWM frequency

6.6. Speed control V_{SP} pin

An analog voltage applied to the V_{SP} pin is converted by the 6 bit AD converter to control the duty cycle of the PWM.

$$0 \leq V_{DUTY} \leq V_{AD} (L)$$

→ Duty cycle = 0 %

$$V_{AD} (L) \leq V_{DUTY} \leq V_{AD} (H)$$

→ Figure at the right (1/64 to 63/64)

$$V_{AD} (H) \leq V_{DUTY} \leq V_{DD}$$

→ Duty cycle = 100 % (63/64)

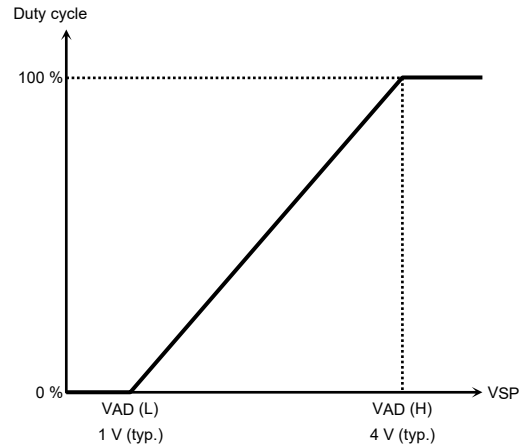
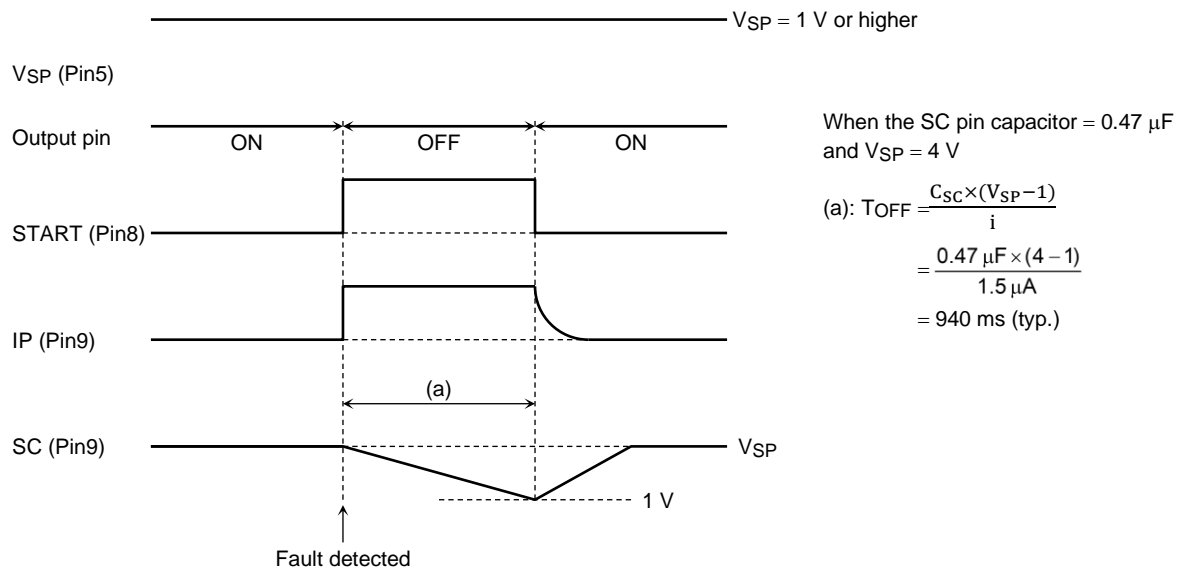

Figure 6.6 Speed control V_{SP} pin

6.7. Fault protection

When a signal indicating the following faults is applied to the WAVE pin, the output transistors are disabled. After about one second, the motor is restarted. This operation is repeated as long as a fault is detected.

- The maximum commutation frequency is exceeded.
- The rotation speed falls below the forced commutation frequency.



When the SC pin capacitor = 0.47 μF and V_{SP} = 4 V

$$(a): T_{OFF} = \frac{C_{SC} \times (V_{SP} - 1)}{i}$$

$$= \frac{0.47 \mu F \times (4 - 1)}{1.5 \mu A}$$

$$= 940 \text{ ms (typ.)}$$

Figure 6.7 Fault protection

6.8. Motor position detection error

A position detection is synchronized with the PWM signal generated in the IC. Thus, a position detection error relative to the PWM signal frequency may occur. Keep this in mind especially when the TB6575FNG is used for a high-speed motor.

A detection is performed on the falling edge of the PWM signal. An error is recognized when the pin voltage exceeds the reference voltage.

Detection error time $< 1/f_p$ f_p : PWM frequency = $f_{XT}/256$ f_{XT} : Ceramic oscillator frequency

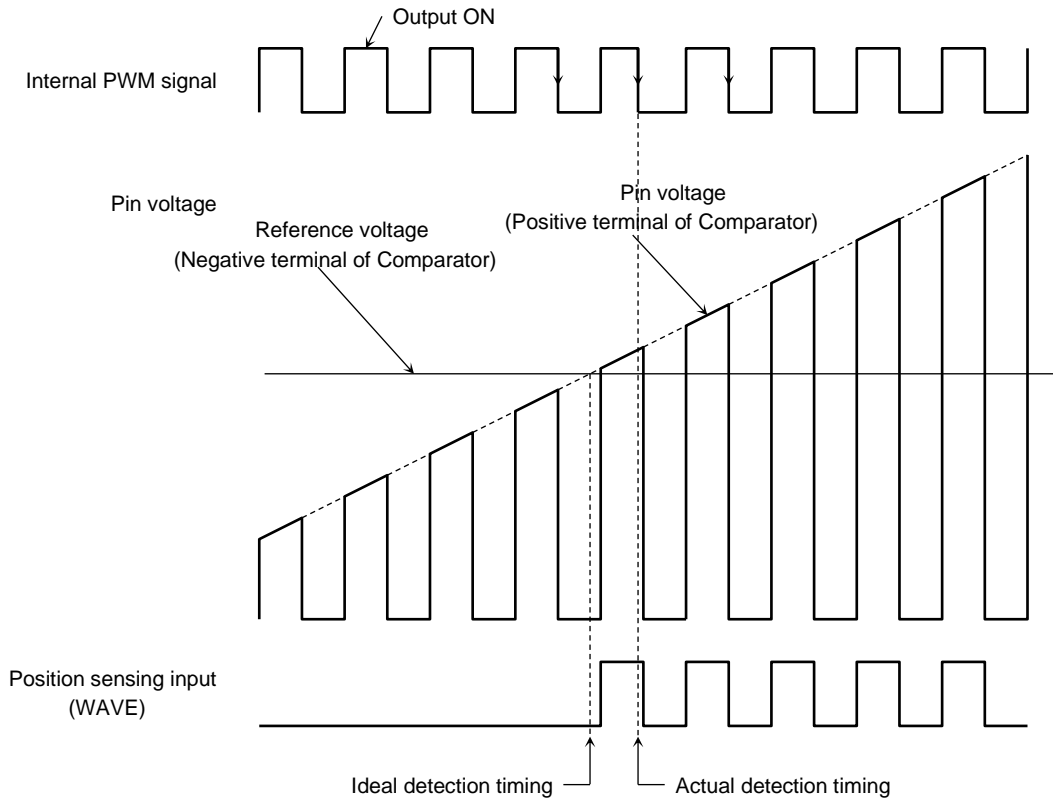

Figure 6.8.1 Motor position detection error 1

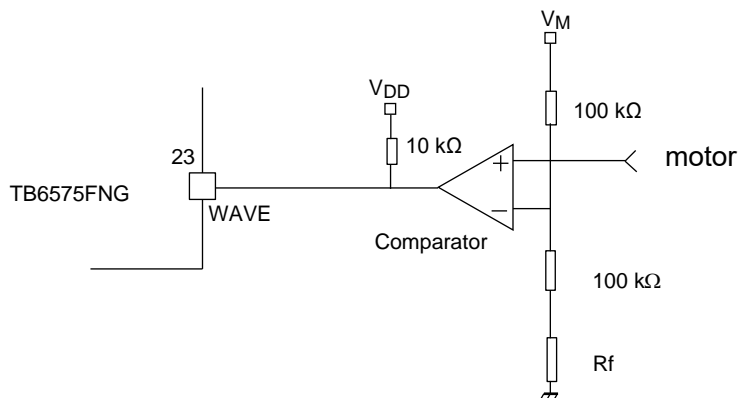

Figure 6.8.2 Motor position detection error 2

6.9. Lead angle control

The motor runs with a lead angle of 0° in forced commutation mode at startup. After switching to natural commutation, the lead angle automatically changes to the value set by the LA pin.

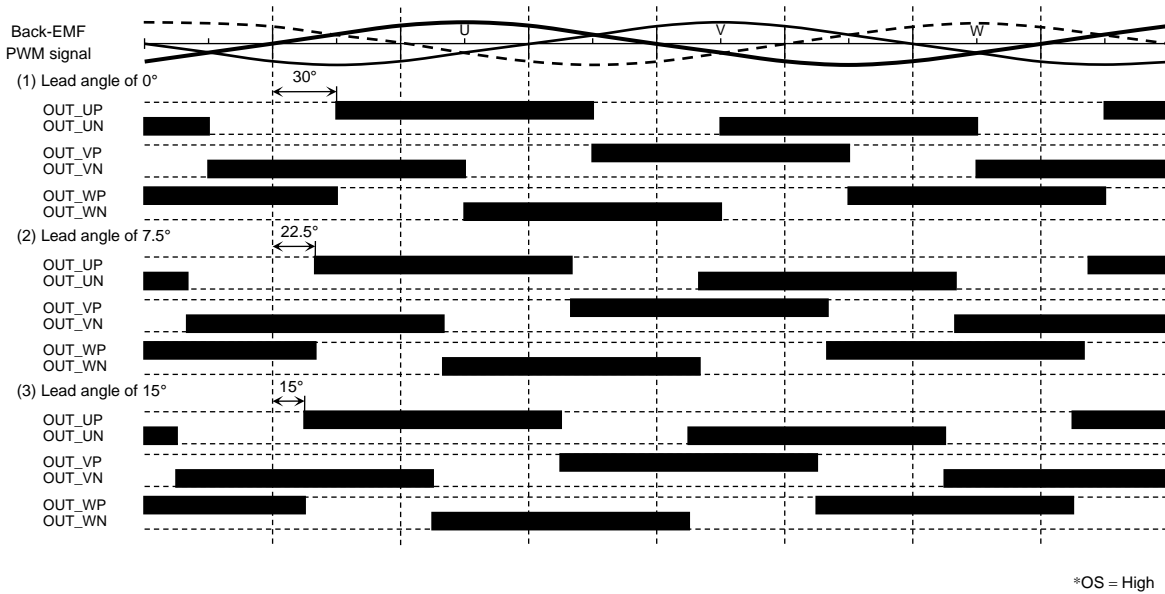

Figure 6.9 Lead angle control

6.10. Overlap commutation

When SEL_LAP = high, the TB6575FNG is configured to allow for 120 ° commutation. When SEL_LAP = low, it is configured to allow for overlap commutation. In overlap commutation, there is an overlap period during which both the outgoing transistor and incoming transistor are conducting (as shown in the shaded areas). This period varies according to the lead angle.

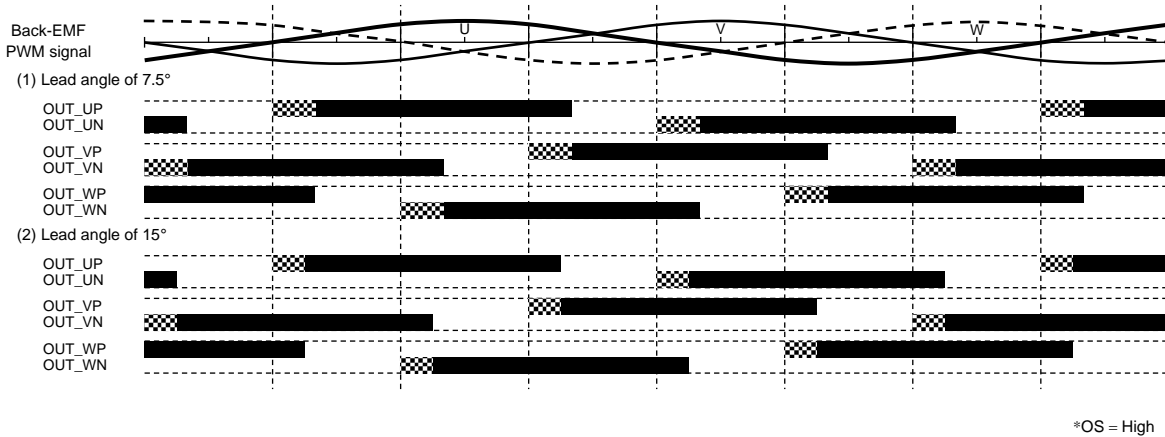

Figure 6.10 Overlap commutation

7. Absolute Maximum Ratings (Ta = 25 °C)

Table 7 Absolute Maximum Ratings

Characteristics	Symbol	Rating	Unit
Power supply voltage	V _{DD}	5.5	V
Input voltage	V _{in}	-0.3 to V _{DD} + 0.3	V
Turn-on signal output current	I _{OUT}	20	mA
Power dissipation	P _D	780 (Note1)	mW
Operating temperature	T _{opr}	-30 to 105	°C
Storage temperature	T _{stg}	-55 to 150	°C

Note1: Without a PCB, stand-alone operation

8. Operating Conditions (Ta = -30 to 105 °C)

Table 8 Operating Conditions

Characteristics	Symbol	Test Condition	Min	Typ.	Max	Unit
Power supply voltage	V _{DD}	-	4.5	5.0	5.5	V
Input voltage	V _{in}	-	-0.3	-	V _{DD} + 0.3	V
Oscillation frequency	f _X T	-	2.0	4.0	8.0	MHz

9. Electrical Specifications (Ta= 25 °C, V_{DD}= 5 V)

Table 9 Electrical Specifications

Characteristics	Symbol	Test Circuit	Test Condition	Min	Typ.	Max	Unit
Rest power supply current	I _{DD}	-	V _{SP} = 0 V, X _{Tin} = H	-	0.7	1	mA
Operating power supply current	I _{DD (opr)}	-	V _{SP} = 2.5 V, X _{Tin} = 4 MHz, Output open	-	2	6	mA
Input current	I _{IN-1 (H)}	-	V _{IN} = 5 V, OC, WAVE, SEL_LAP, F _{MAX} , F _{ST} , OS	-	0	1	μA
	I _{IN-1 (L)}	-	V _{IN} = 0 V, OC, WAVE, SEL_LAP, F _{MAX} , F _{ST} , OS	-75	-50	-	
	I _{IN-2 (H)}	-	V _{IN} = 5 V, CW_CCW, LA, V _{SP}	-	50	75	
	I _{IN-2 (L)}	-	V _{IN} = 0 V, CW_CCW, LA, V _{SP}	-1	0	-	
	I _{IN-3 (H)}	-	V _{IN} = 5 V, V _{SP}	-	90	150	
	I _{IN-3 (L)}	-	V _{IN} = 0 V, V _{SP}	-1	0	-	
Input voltage	V _{IN-1 (H)}	-	OC, SEL_LAP, CW_CCW, WAVE, LA, F _{MAX} , OS	3.5	-	5	V
	V _{IN-1 (L)}	-	OC, SEL_LAP, CW_CCW, WAVE, LA, F _{MAX} , OS	GND	-	1.5	
	V _{IN-2 (H)}	-	F _{ST}	4	-	5	
	V _{IN-2 (M)}	-	F _{ST}	2	-	3	
	V _{IN-2 (L)}	-	F _{ST}	GND	-	1	
Input hysteresis voltage	V _H	-	WAVE, IP	-	0.45	-	V
Output voltage	V _{O-1 (H)}	-	I _{OH} = -2 mA OUT_UP, OUT_VP, OUT_WP	4.5	-	V _{DD}	V
	V _{O-1 (L)}	-	I _{OL} = 20 mA OUT_UP, OUT_VP, OUT_WP	GND	-	0.5	
	V _{O-2 (H)}	-	I _{OH} = -20 mA OUT_UN, OUT_VN, OUT_WN	4.5	-	V _{DD}	
	V _{O-2 (L)}	-	I _{OL} = 2 mA OUT_UN, OUT_VN, OUT_WN	GND	-	0.5	
	V _{O-3 (H)}	-	I _{OH} = -0.5 mA FG_OUT	4.5	-	V _{DD}	
	V _{O-3 (L)}	-	I _{OL} = 0.5 mA FG_OUT	GND	-	0.5	
Output leak current	I _{L (H)}	-	V _{DD} = 5.5 V, V _{OUT} = 0 V OUT_UP, OUT_VP, OUT_WP, OUT_UN, OUT_VN, OUT_WN, FG_OUT	-	0	10	μA
	I _{L (L)}	-	V _{DD} = 5.5 V, V _{OUT} = 5.5 V OUT_UP, OUT_VP, OUT_WP, OUT_UN, OUT_VN, OUT_WN, FG_OUT	-	0	10	
PWM input voltage	V _{AD (L)}	-	V _{SP}	0.8	1.0	1.2	V
	V _{AD (H)}			3.8	4.0	4.2	
Csc charge current	I _{SC}	-	SC	2.6	3.8	5.0	μA
Fault retry time	T _{OFF}	-	V _{SP} = 4 V, SC pin = 0.47 μF	-	940	-	ms
Overcurrent detection voltage	V _{OC}	-	OC	0.46	0.5	0.54	V

10. Input Equivalent Circuit

Table 10 Input Equivalent Circuit

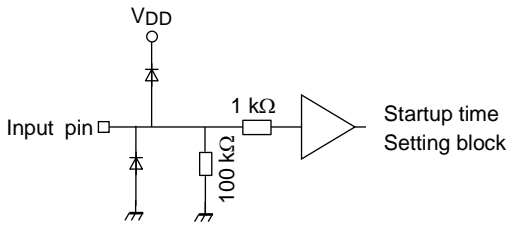
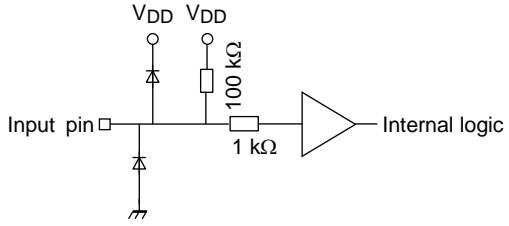
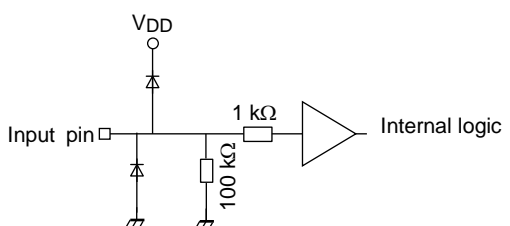
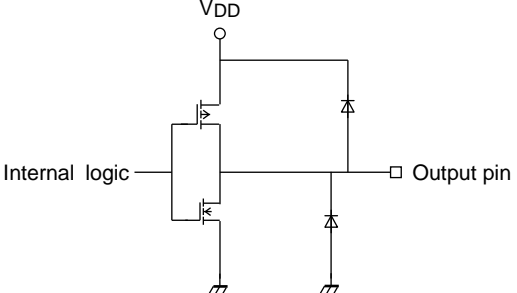
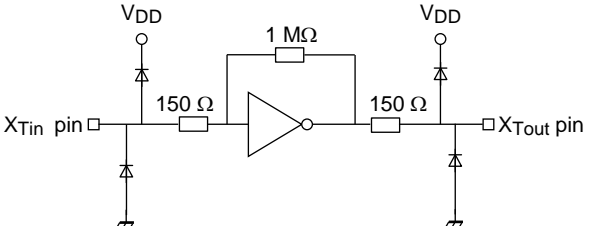
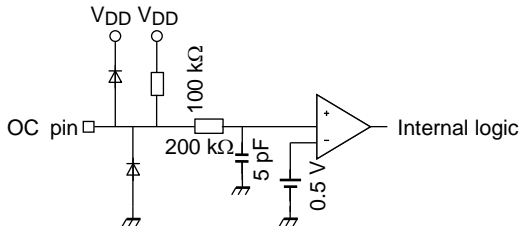
<p>1. VSP pin</p> 	<p>2. SEL_LAP, FMAX, FST, WAVE and OS pins</p>  <p>Hysteresis width WAVE: 450 mV (typ.)</p>
<p>3. LA and CW_CCW pins</p> 	<p>4. OUT_UP, OUT_UN, OUT_VP, OUT_VN, OUT_WP, OUT_WN and FG_OUT pins</p> 
<p>5. XTin and XTout pins</p>	<p>6. OC pin</p>
	

12. Package Dimensions

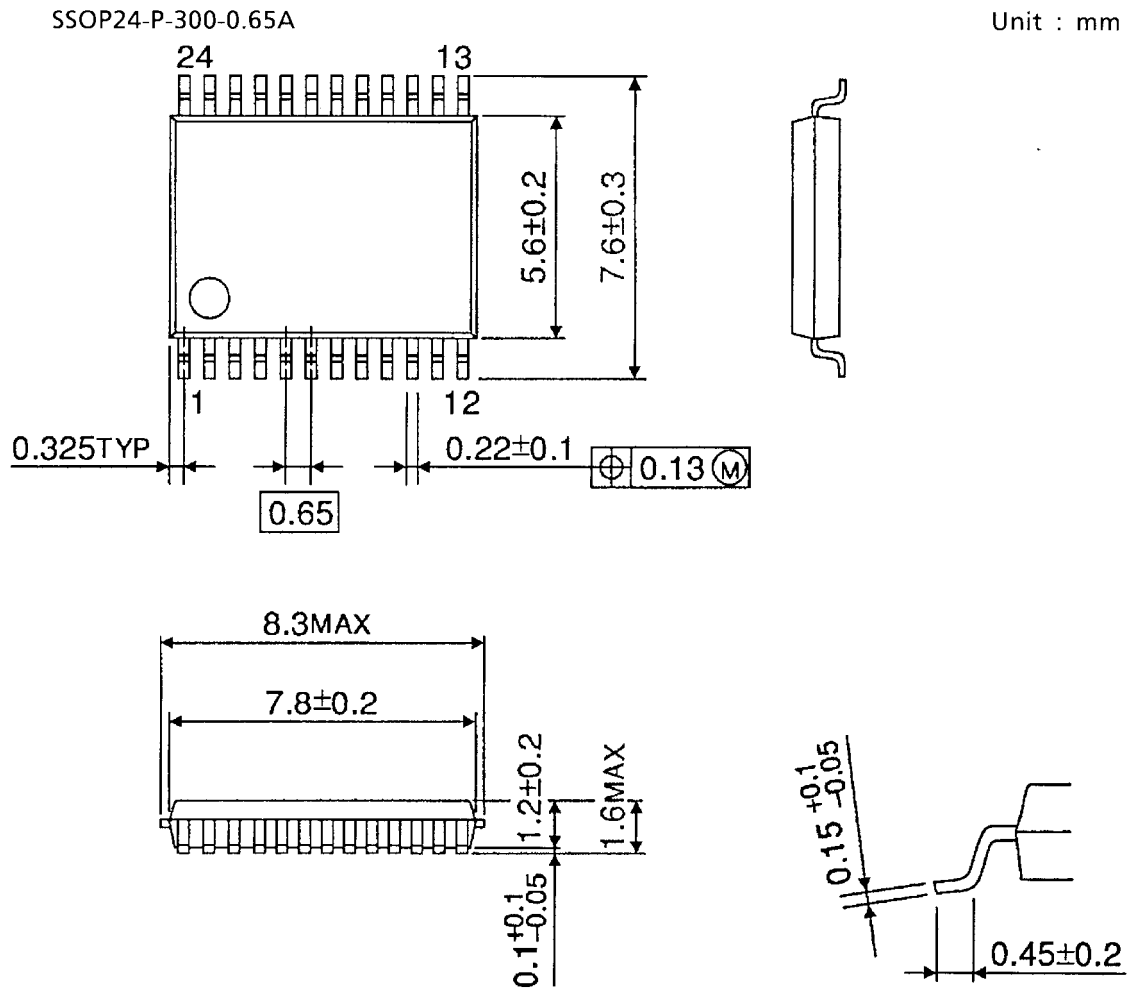

Figure12 Package Dimensions

Weight: 0.14 g (Typ.)

13. Notes on Contents

Block Diagrams

Some of the functional blocks, circuits, or constants in the block diagram may be omitted or simplified for explanatory purposes.

Timing Charts

Timing charts may be simplified for explanatory purposes.

Application Circuits

The application circuits shown in this document are provided for reference purposes only. Thorough evaluation is required, especially at the mass production design stage. Providing these application circuit examples does not grant a license for industrial property rights.

14. IC Usage Considerations

14.1. Notes on Handling of ICs

- (1) The absolute maximum ratings of a semiconductor device are a set of ratings that must not be exceeded, even for a moment. Do not exceed any of these ratings. Exceeding the rating(s) may cause the device breakdown, damage or deterioration, and may result injury by explosion or combustion.
- (2) Use an appropriate power supply fuse to ensure that a large current does not continuously flow in case of over current and/or IC failure. The IC will fully break down when used under conditions that exceed its absolute maximum ratings, when the wiring is routed improperly or when an abnormal pulse noise occurs from the wiring or load, causing a large current to continuously flow and the breakdown can lead smoke or ignition. To minimize the effects of the flow of a large current in case of breakdown, appropriate settings, such as fuse capacity, fusing time and insertion circuit location, are required.
- (3) If your design includes an inductive load such as a motor coil, incorporate a protection circuit into the design to prevent device malfunction or breakdown caused by the current resulting from the inrush current at power ON or the negative current resulting from the back electromotive force at power OFF. IC breakdown may cause injury, smoke or ignition. Use a stable power supply with ICs with built-in protection functions. If the power supply is unstable, the protection function may not operate, causing IC breakdown. IC breakdown may cause injury, smoke or ignition.
- (4) Do not insert devices in the wrong orientation or incorrectly. Make sure that the positive and negative terminals of power supplies are connected properly. Otherwise, the current or power consumption may exceed the absolute maximum rating, and exceeding the rating(s) may cause the device breakdown, damage or deterioration, and may result injury by explosion or combustion. In addition, do not use any device that is applied the current with inserting in the wrong orientation or incorrectly even just one time.
- (5) Carefully select external components (such as inputs and negative feedback capacitors) and load components (such as speakers), for example, power amp and regulator. If there is a large amount of leakage current such as from input or negative feedback condenser, the IC output DC voltage will increase. If this output voltage is connected to a speaker with low input withstand voltage, overcurrent or IC failure may cause smoke or ignition. (The overcurrent may cause smoke or ignition from the IC itself.) In particular, please pay attention when using a Bridge Tied Load (BTL) connection-type IC that inputs output DC voltage to a speaker directly.

14.2. Points to Remember on Handling of ICs

(1) Over current Protection Circuit

Over current protection circuits (referred to as current limiter circuits) do not necessarily protect ICs under all circumstances. If the Over current protection circuits operate against the over current, clear the over current status immediately.

Depending on the method of use and usage conditions, such as exceeding absolute maximum ratings can cause the over current protection circuit to not operate properly or IC breakdown before operation. In addition, depending on the method of use and usage conditions, if over current continues to flow for a long time after operation, the IC may generate heat resulting in breakdown.

(2) Thermal Shutdown Circuit

Thermal shutdown circuits do not necessarily protect ICs under all circumstances. If the thermal shutdown circuits operate against the over temperature, clear the heat generation status immediately. Depending on the method of use and usage conditions, such as exceeding absolute maximum ratings can cause the thermal shutdown circuit to not operate properly or IC breakdown before operation.

(3) Heat Radiation Design

In using an IC with large current flow such as power amp, regulator or driver, please design the device so that heat is appropriately radiated, not to exceed the specified junction temperature (T_j) at any time and condition. These ICs generate heat even during normal use. An inadequate IC heat radiation design can lead to decrease in IC life, deterioration of IC characteristics or IC breakdown. In addition, please design the device taking into consideration the effect of IC heat radiation with peripheral components.

(4) Back-EMF

When a motor reverses the rotation direction, stops or slows down abruptly, a current flow back to the motor's power supply due to the effect of back-EMF. If the current sink capability of the power supply is small, the device's motor power supply and output pins might be exposed to conditions beyond absolute maximum ratings. To avoid this problem, take the effect of back-EMF into consideration in system design.

RESTRICTIONS ON PRODUCT USE

- Toshiba Corporation and its subsidiaries and affiliates are collectively referred to as "TOSHIBA". Hardware, software and systems described in this document are collectively referred to as "Product".
- TOSHIBA reserves the right to make changes to the information in this document and related Product without notice.
- This document and any information herein may not be reproduced without prior written permission from TOSHIBA. Even with TOSHIBA's written permission, reproduction is permissible only if reproduction is without alteration/omission.
- Though TOSHIBA works continually to improve Product's quality and reliability, Product can malfunction or fail. Customers are responsible for complying with safety standards and for providing adequate designs and safeguards for their hardware, software and systems which minimize risk and avoid situations in which a malfunction or failure of Product could cause loss of human life, bodily injury or damage to property, including data loss or corruption. Before customers use the Product, create designs including the Product, or incorporate the Product into their own applications, customers must also refer to and comply with (a) the latest versions of all relevant TOSHIBA information, including without limitation, this document, the specifications, the data sheets and application notes for Product and the precautions and conditions set forth in the "TOSHIBA Semiconductor Reliability Handbook" and (b) the instructions for the application with which the Product will be used with or for. Customers are solely responsible for all aspects of their own product design or applications, including but not limited to (a) determining the appropriateness of the use of this Product in such design or applications; (b) evaluating and determining the applicability of any information contained in this document, or in charts, diagrams, programs, algorithms, sample application circuits, or any other referenced documents; and (c) validating all operating parameters for such designs and applications. **TOSHIBA ASSUMES NO LIABILITY FOR CUSTOMERS' PRODUCT DESIGN OR APPLICATIONS.**
- **PRODUCT IS NEITHER INTENDED NOR WARRANTED FOR USE IN EQUIPMENTS OR SYSTEMS THAT REQUIRE EXTRAORDINARILY HIGH LEVELS OF QUALITY AND/OR RELIABILITY, AND/OR A MALFUNCTION OR FAILURE OF WHICH MAY CAUSE LOSS OF HUMAN LIFE, BODILY INJURY, SERIOUS PROPERTY DAMAGE AND/OR SERIOUS PUBLIC IMPACT ("UNINTENDED USE").** Except for specific applications as expressly stated in this document, Unintended Use includes, without limitation, equipment used in nuclear facilities, equipment used in the aerospace industry, Class 3 medical devices, equipment used for automobiles, and military vehicles and munitions. **IF YOU USE PRODUCT FOR UNINTENDED USE, TOSHIBA ASSUMES NO LIABILITY FOR PRODUCT.** For details, please contact your TOSHIBA sales representative or contact us via our website.
- Do not disassemble, analyze, reverse-engineer, alter, modify, translate or copy Product, whether in whole or in part.
- Product shall not be used for or incorporated into any products or systems whose manufacture, use, or sale is prohibited under any applicable laws or regulations.
- The information contained herein is presented only as guidance for Product use. No responsibility is assumed by TOSHIBA for any infringement of patents or any other intellectual property rights of third parties that may result from the use of Product. No license to any intellectual property right is granted by this document, whether express or implied, by estoppel or otherwise.
- **ABSENT A WRITTEN SIGNED AGREEMENT, EXCEPT AS PROVIDED IN THE RELEVANT TERMS AND CONDITIONS OF SALE FOR PRODUCT, AND TO THE MAXIMUM EXTENT ALLOWABLE BY LAW, TOSHIBA (1) ASSUMES NO LIABILITY WHATSOEVER, INCLUDING WITHOUT LIMITATION, INDIRECT, CONSEQUENTIAL, SPECIAL, OR INCIDENTAL DAMAGES OR LOSS, INCLUDING WITHOUT LIMITATION, LOSS OF PROFITS, LOSS OF OPPORTUNITIES, BUSINESS INTERRUPTION AND LOSS OF DATA, AND (2) DISCLAIMS ANY AND ALL EXPRESS OR IMPLIED WARRANTIES AND CONDITIONS RELATED TO SALE, USE OF PRODUCT, OR INFORMATION, INCLUDING WARRANTIES OR CONDITIONS OF MERCHANTABILITY, FITNESS FOR A PARTICULAR PURPOSE, ACCURACY OF INFORMATION, OR NONINFRINGEMENT.**
- Do not use or otherwise make available Product or related software or technology for any military purposes, including without limitation, for the design, development, use, stockpiling or manufacturing of nuclear, chemical, or biological weapons or missile technology products (mass destruction weapons). Product and related software and technology may be controlled under the applicable export laws and regulations including, without limitation, the Japanese Foreign Exchange and Foreign Trade Law and the U.S. Export Administration Regulations. Export and re-export of Product or related software or technology are strictly prohibited except in compliance with all applicable export laws and regulations.
- Please contact your TOSHIBA sales representative for details as to environmental matters such as the RoHS compatibility of Product. Please use Product in compliance with all applicable laws and regulations that regulate the inclusion or use of controlled substances, including without limitation, the EU RoHS Directive. **TOSHIBA ASSUMES NO LIABILITY FOR DAMAGES OR LOSSES OCCURRING AS A RESULT OF NONCOMPLIANCE WITH APPLICABLE LAWS AND REGULATIONS.**