

# **3kW Power Supply for Servers and Telecoms Using Surface-Mounted SiC MOSFET**

## **Reference Guide**

**RD244-RGUIDE-02**

---

**Toshiba Electronic Devices & Storage Corporation**

## Table of Contents

<b>1. Introduction .....</b>	<b>3</b>
<b>2. Appearance and Specifications .....</b>	<b>4</b>
2.1. Specifications .....	4
2.2. Block Diagram.....	4
2.3. Appearance .....	5
2.4. PCB Component Layout.....	6
<b>3. Schematic, Bill of Materials, and PCB Pattern Diagram .....</b>	<b>9</b>
3.1. Schematic.....	9
3.2. Bill of Materials .....	9
3.3. PCB Pattern Diagram .....	9
<b>4. Operating Procedure.....</b>	<b>16</b>
4.1. Connecting to an External Device .....	16
4.2. Start and Stop Procedures .....	16
4.3. Evaluation Precautions (Electric Shock, Burn Injury, etc.) .....	16
<b>5. Power Characteristics .....</b>	<b>17</b>
5.1. Efficiency .....	17

## 1. Introduction

This reference guide describes the specifications, usage, and characteristics of the 3kW power supply for servers and telecoms with surface mounted SiC MOSFETs (hereafter referred to as "this design").

In recent years, data centers have become increasingly large and dense. As a result, server power supplies are required to deliver higher efficiency, higher power output, and more compact form factors, making high power density essential. This design accepts an AC input voltage range of 180 to 264V and outputs DC 50V through a semi-bridgeless PFC (Power Factor Correction) circuit and a Phase Shift Full Bridge (PSFB) circuit. The maximum output power is 3kW when using an AC 200V input. It includes an output ORing circuit that enables redundant operation, as well as an internal auxiliary power supply circuit required for powering internal control circuits. By separating the power devices from the main board, the footprint per output is reduced, contributing to a more compact power supply. In addition to server applications, this design can be applied to telecom systems and other applications that utilize 48V.

This design uses the SiC MOSFET [TW092V65C](#) and the SiC Schottky Barrier Diode [TRS12V65H](#) in the semi-bridgeless PFC circuit. The PSFB circuit uses the SiC MOSFET [TW027U65C](#) with integrated Schottky Barrier Diode on the primary full-bridge side, and the power MOSFET [TPW2900ENH](#) on the secondary synchronous rectification side. For isolated gate signal transmission from the secondary-side controller, the digital isolator [DCL540C01](#) is used. The output ORing circuit uses the power MOSFET [TPM1R908QM](#). By integrating these advanced Toshiba devices, this design achieves high efficiency equivalent to 80PLUS Platinum level ( $V_{in} = 230V$ ,  $P_{out} = 3kW$ ) in a compact form factor.

**Note:**

80 PLUS is an efficiency certification standard for computer power supply units, including those used in servers.

## 2. Appearance and Specifications

### 2.1. Specifications

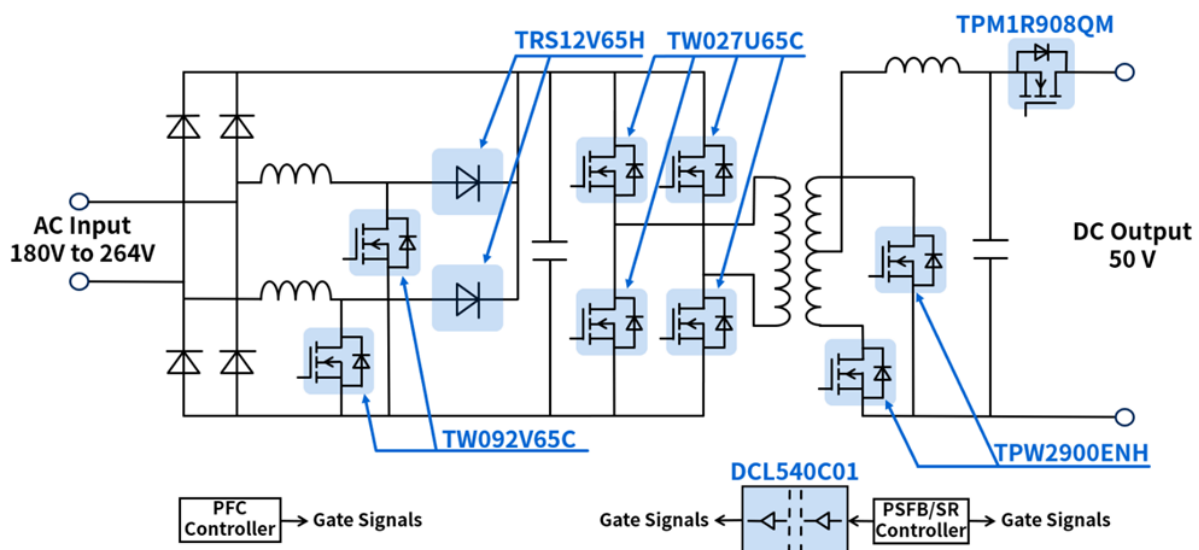
Table 2.1 lists the input and output characteristics of this design.

**Table 2.1 Specifications**

Parameters	Conditions	Min.	Typ.	Max.	Unit
<b>Input Characteristics</b>					
AC input voltage (rms)		180		264	V
AC input current (rms)	$V_{in} = AC\ 90V, I_{out} = 30A$			18.5	A
Input frequency		47		63	Hz
<b>Internal Characteristics (Semi-Bridgeless PFC Circuit)</b>					
Output voltage			390		V
Output power	$V_{in} = AC\ 230V$			3	kW
Switching frequency			100		kHz
<b>Output Characteristics (PSFB Circuit)</b>					
Output voltage			50		V
Output current	$V_{in} = AC\ 230V$			60	A
Output power	$V_{in} = AC\ 230V$			3	kW
Output ripple voltage	$T_a = 25^{\circ}C$			500	mV
Switching frequency			130		kHz
<b>Other</b>					
Protection	Output Overvoltage Protection, Output Overcurrent Protection Output Short-Circuit Protection, Overtemperature Protection				
Substrate structure	Main Board: FR-4, 6-Layers (through-hole via), 1.6mm Cu Thickness 70 $\mu$ m (outer layers), 35 $\mu$ m (inner layers) PFC Board: FR-4, 6-Layers (resin-filled via), 1.0mm Cu Thickness 70 $\mu$ m (outer layers), 35 $\mu$ m (inner layers) Main Board: FR-4, 6-Layers (resin-filled via), 1.0mm Cu Thickness 70 $\mu$ m (outer layers), 35 $\mu$ m (inner layers)				

### 2.2. Block Diagram

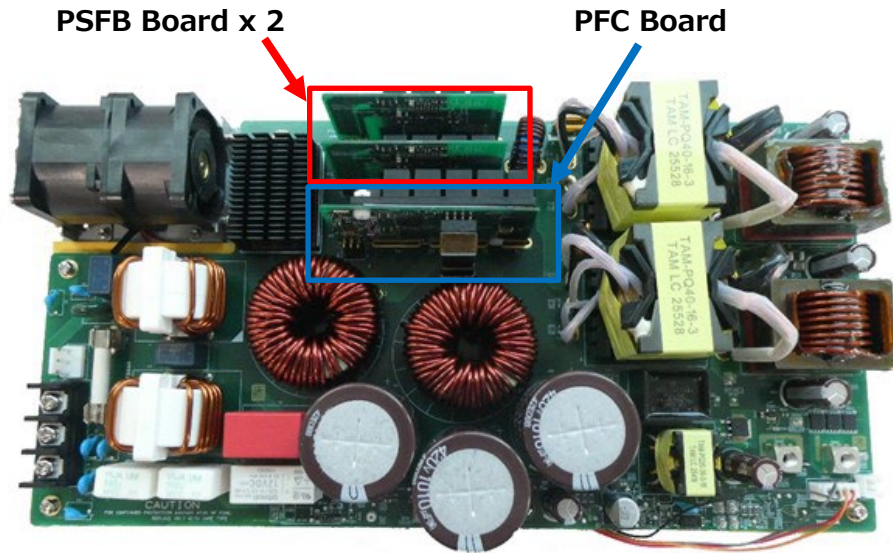
Fig. 2.1 shows a block diagram to understand the function.



**Fig. 2.1 Block Diagram**

### 2.3. Appearance

Fig. 2.2 shows the appearance of this design.  
This design consists of a Main board, a PFC board, and two PSFB boards.

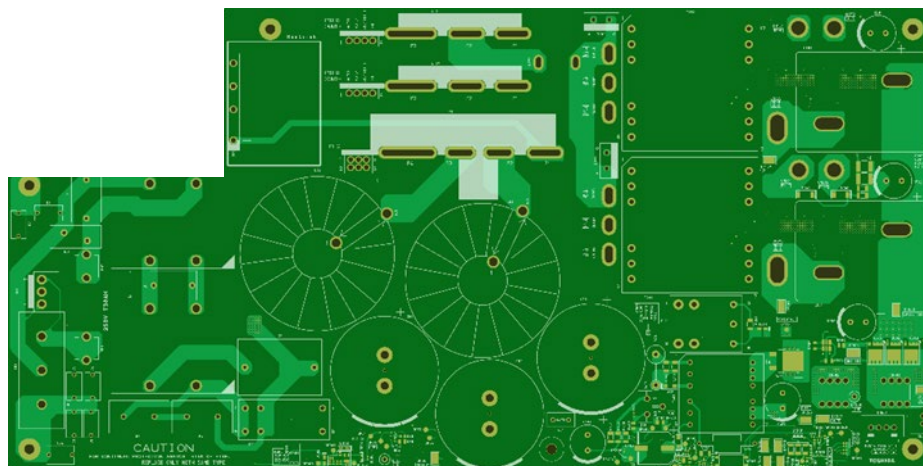


**Fig. 2.2 External View of This Design**

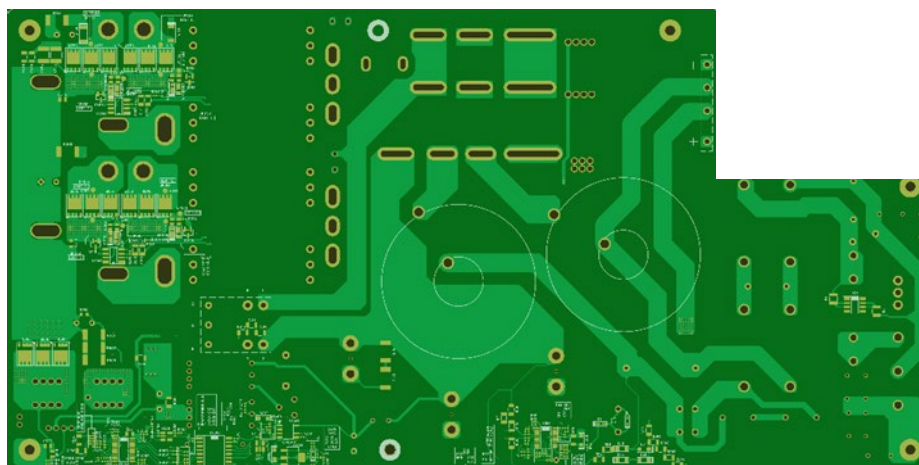
External Dimensions : 300mm x 150mm x 54mm

## 2.4. PCB Component Layout

Fig. 2.3 shows the component layout of the main board, Fig. 2.4 shows the component layout of the PFC board, Fig. 2.5 shows the component layout of the PSFB board.



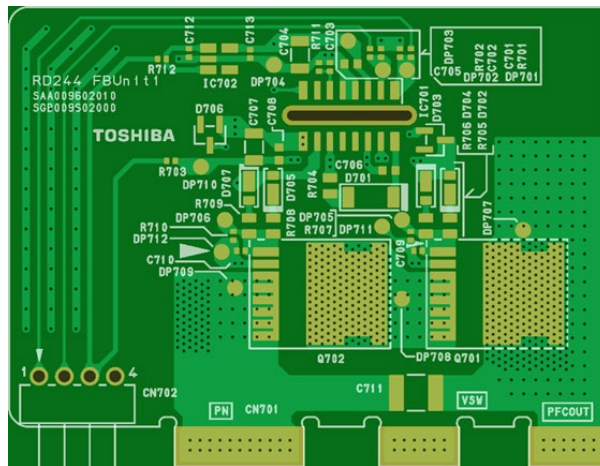
<Front>



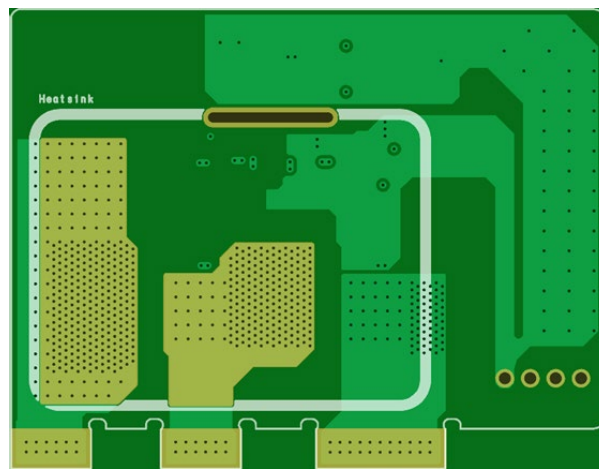
<Back>

**Fig. 2.3 Component Layout of Main Board**





<Front>



<Back>

**Fig. 2.5 Component Layout of PSFB Board**

## **3. Schematic, Bill of Materials, and PCB Pattern Diagram**

### **3.1. Schematic**

Refer to following files:

Main board : RD244-SCHEMATIC1-xx.pdf

PFC board : RD244-SCHEMATIC2-xx.pdf

PSFB board : RD244-SCHEMATIC3-xx.pdf

The same PSFB board is used twice.

(xx is the revision number.)

### **3.2. Bill of Materials**

Refer to following files:

Main board : RD244-BOM1-xx.pdf

PFC board : RD244-BOM2-xx.pdf

PSFB board : RD244-BOM3-xx.pdf

The same PSFB board is used twice.

(xx is the revision number.)

### **3.3. PCB Pattern Diagram**

Fig. 3.1 shows PCB pattern diagram of the main board, Fig. 3.2 shows PCB pattern diagram of the PFC board, Fig. 3.3 shows PCB pattern diagram of the PSFB board.

Refer to following files:

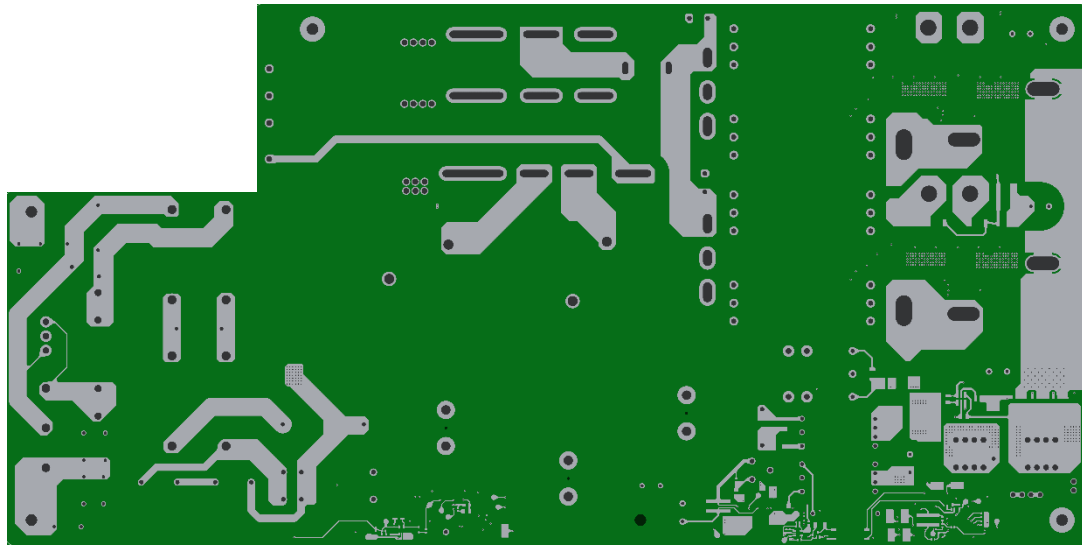
Main board : RD244-LAYER1-xx.pdf

PFC board : RD244-LAYER2-xx.pdf

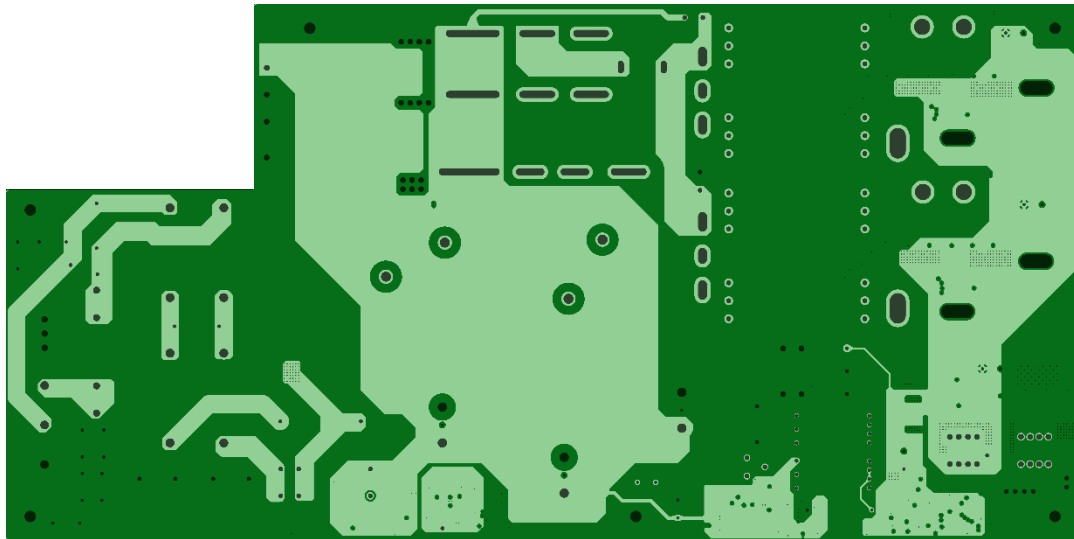
PSFB board : RD244-LAYER3-xx.pdf

The same PSFB board is used twice.

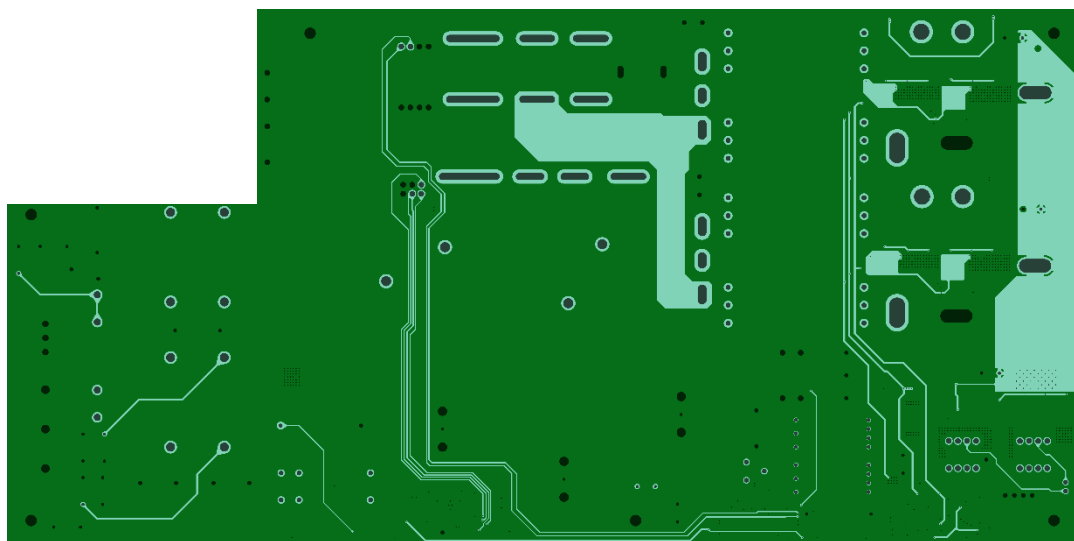
(xx is the revision number.)



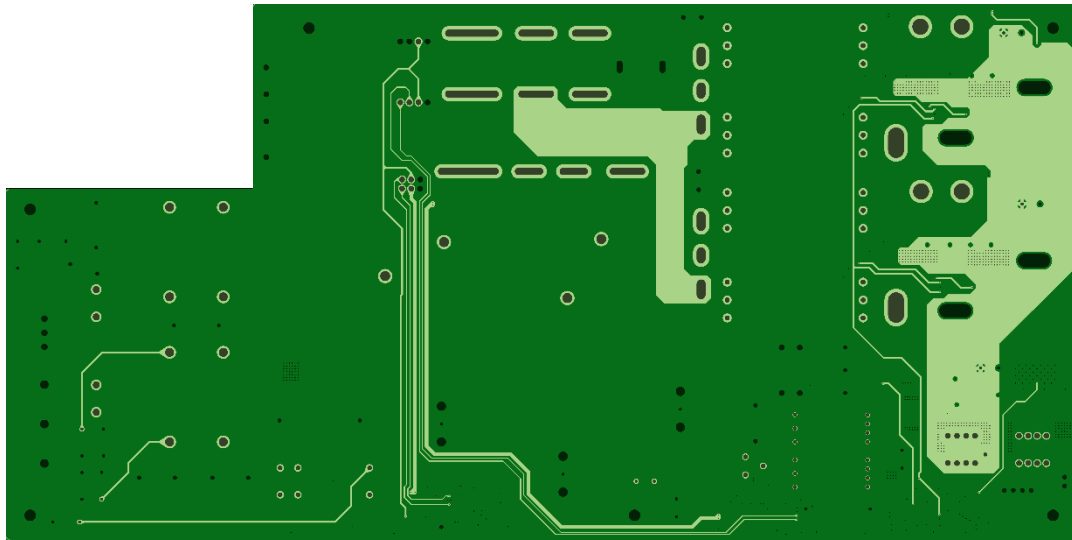
<Layer1、Front>



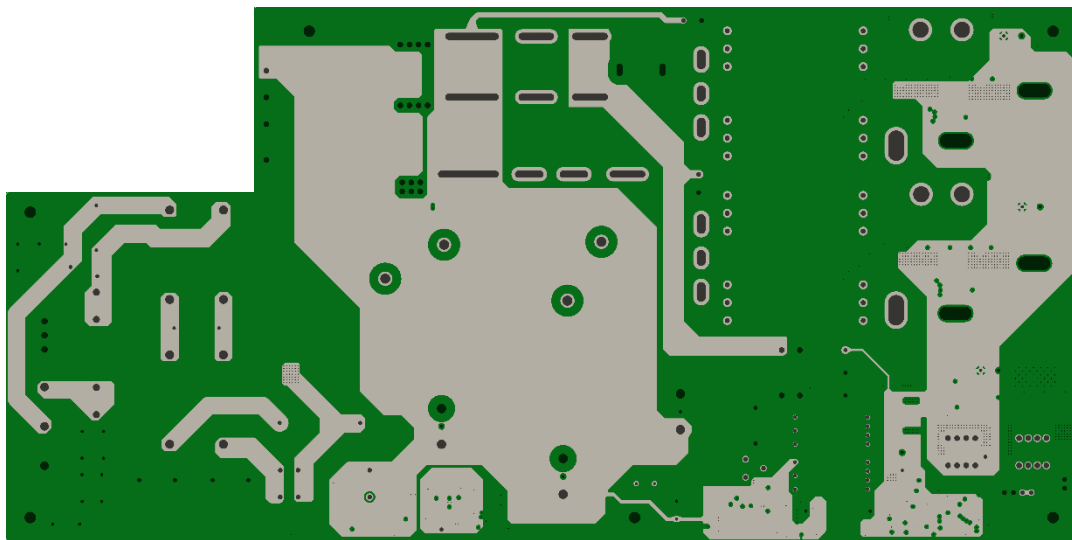
<Layer2>



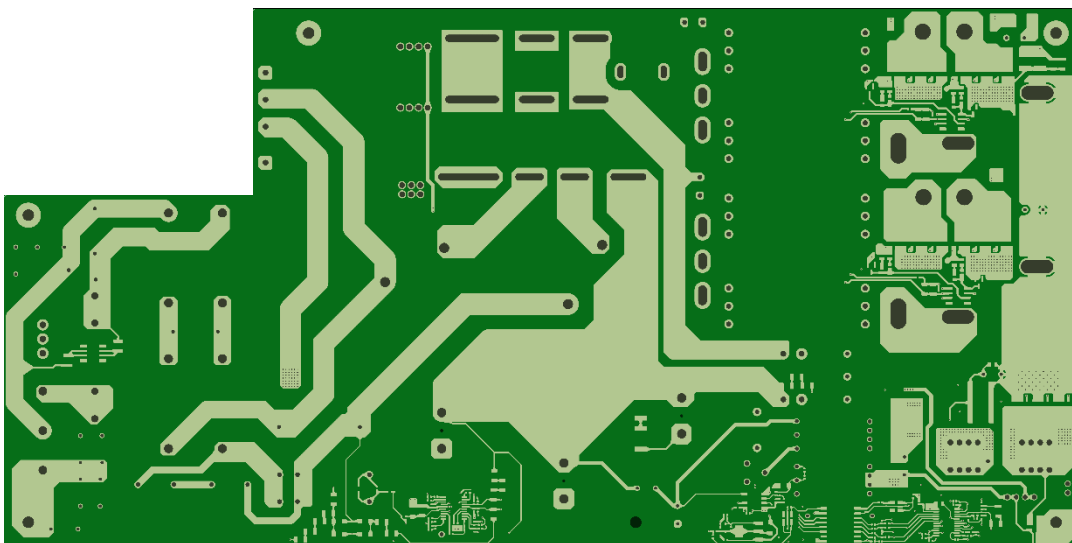
<Layer3>



<Layer4>

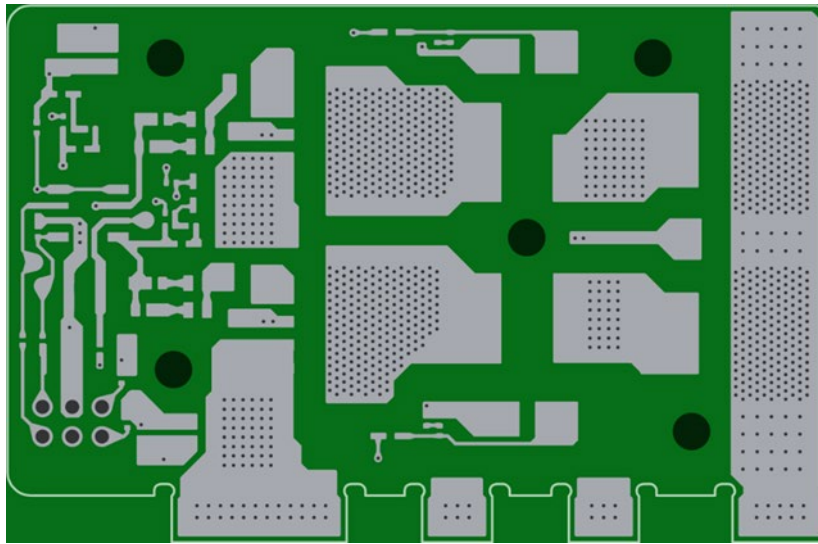


<Layer5>

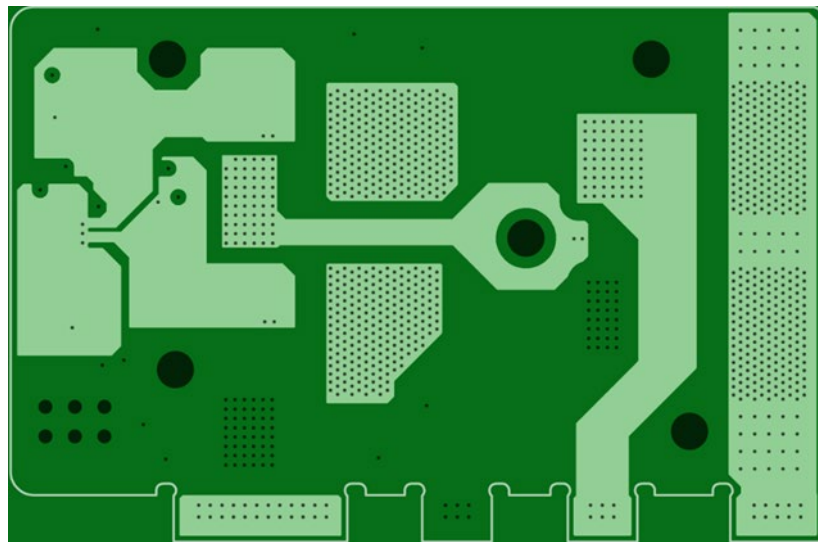


<Layer6, Back>

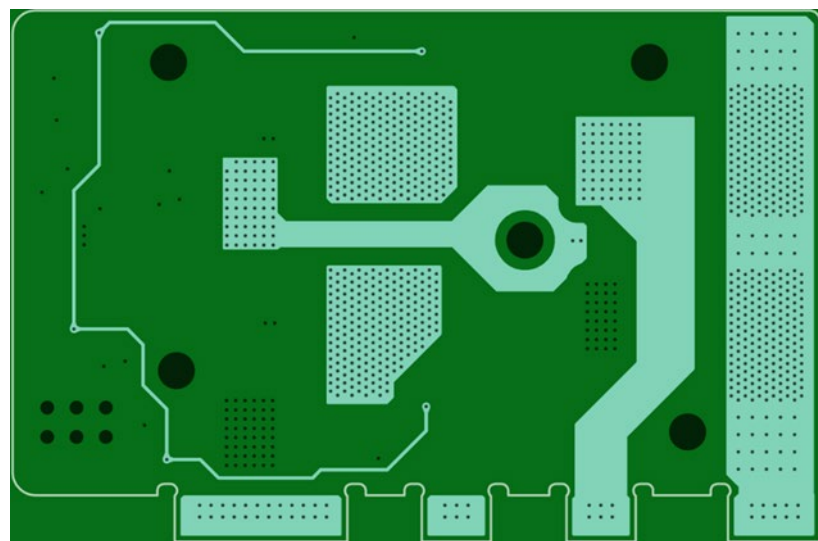
**Fig. 3.1 Main Board Pattern Diagram (Front View)**



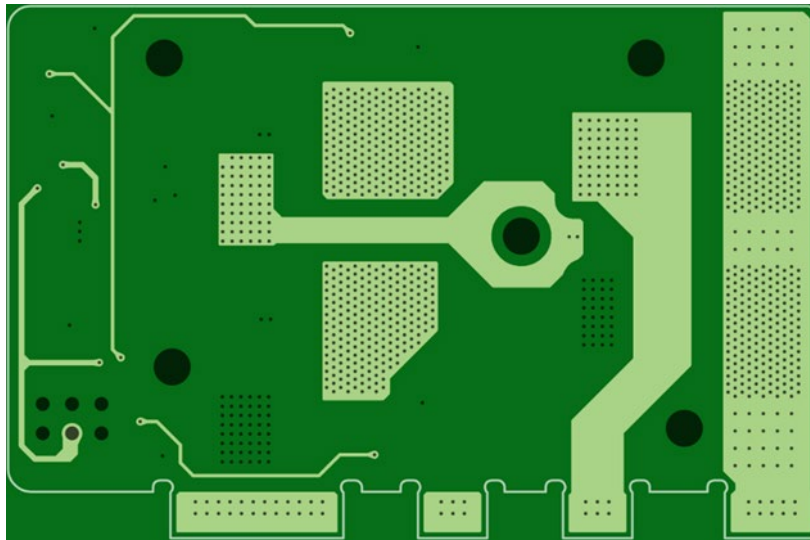
<Layer1, Front>



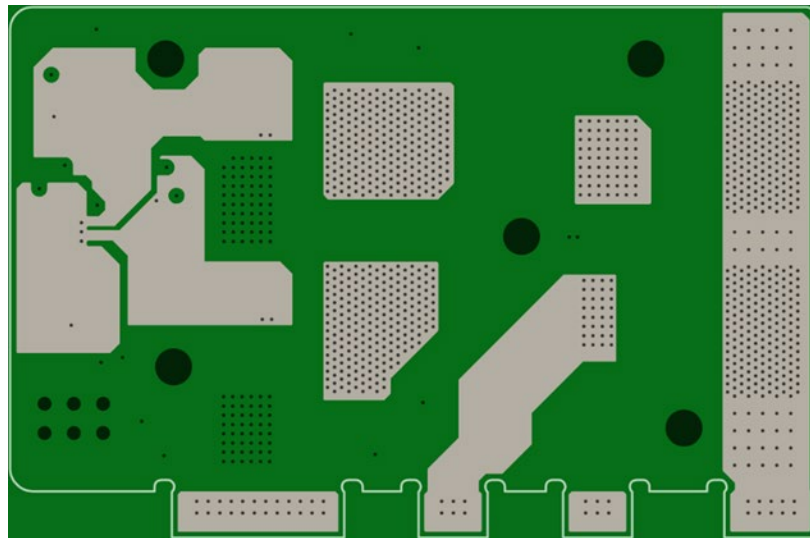
<Layer2>



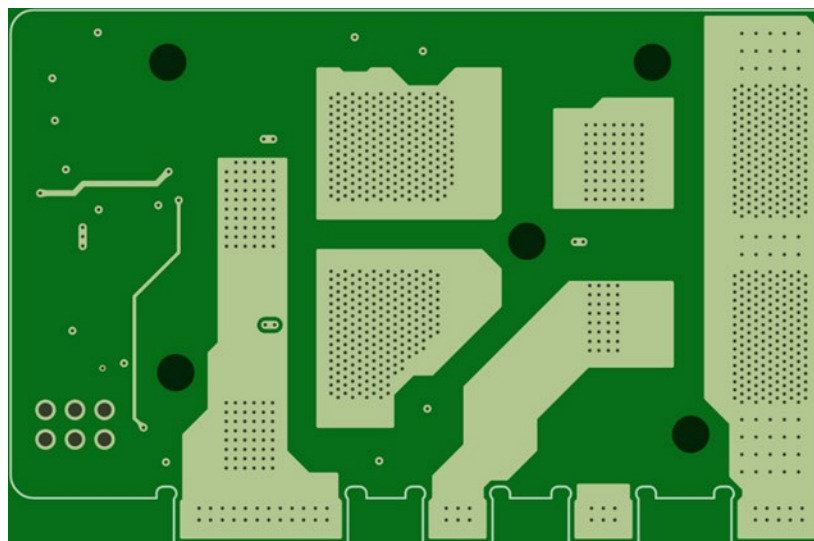
<Layer3>



<Layer4>

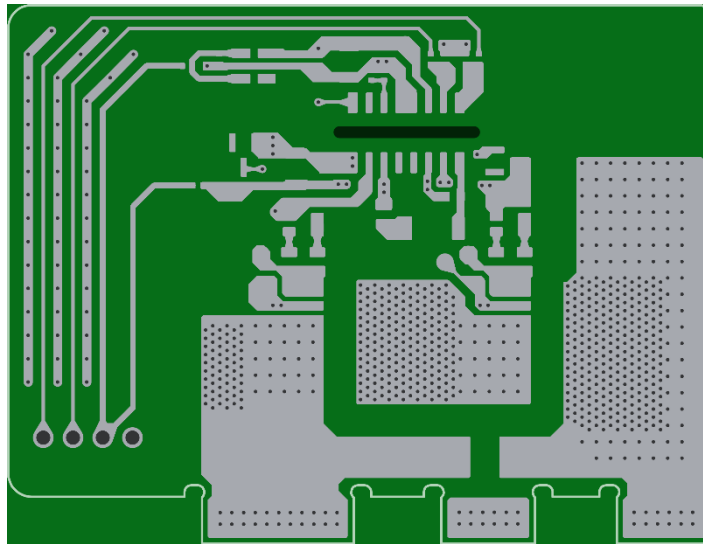


<Layer5>

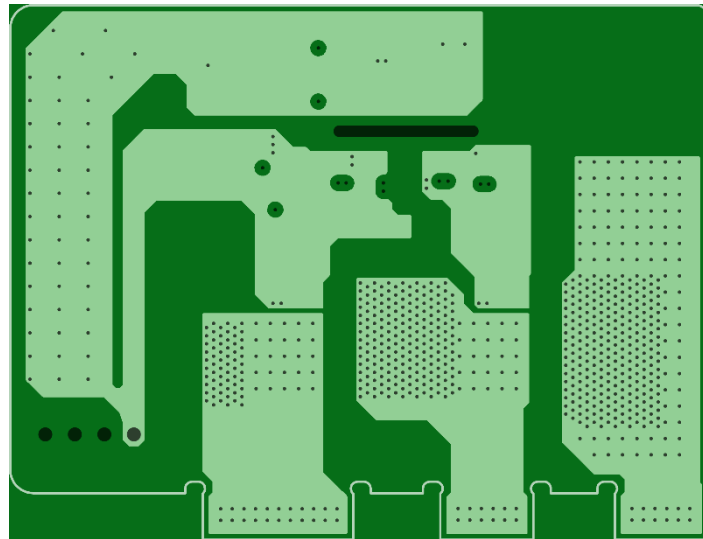


<Layer6, Back>

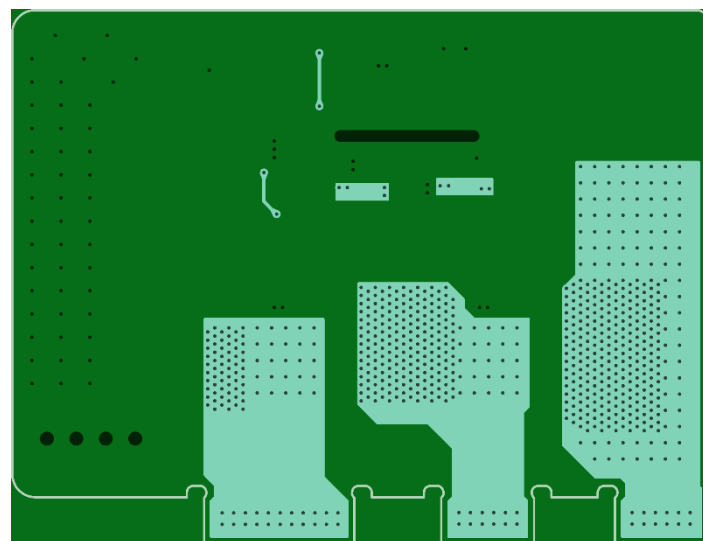
**Fig. 3.2 PFC Board Pattern Diagram (Front View)**



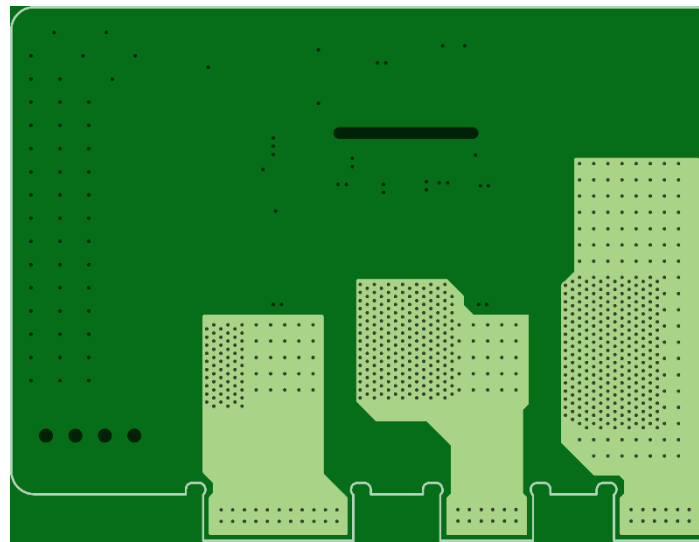
<Layer1, Front>



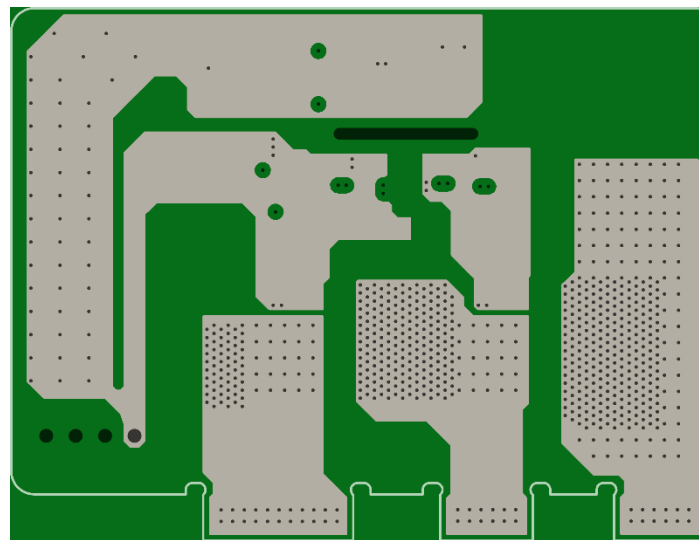
<Layer2>



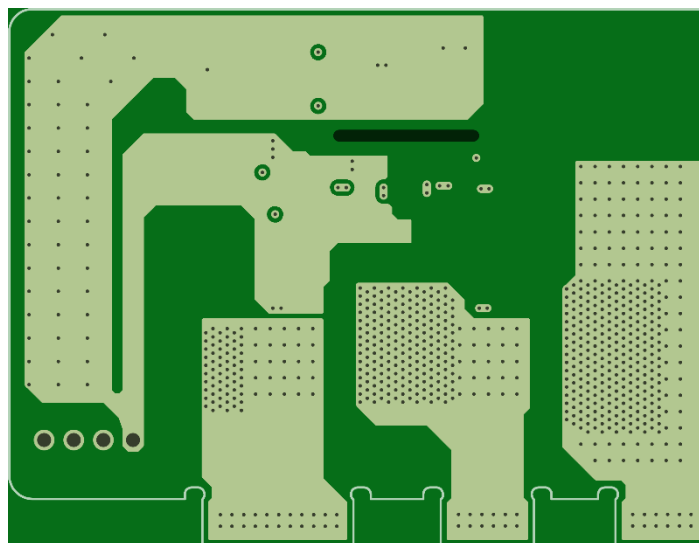
<Layer3>



<Layer4>



<Layer5>



<Layer6, Back>

**Fig. 3.3 PSFB Board Pattern Diagram (Front View)**

## 4. Operating Procedure

### 4.1. Connecting to an External Device

Fig. 4.2 shows the external connection terminals of this design. The area outlined in red indicates the AC input terminal (TB1), and the area outlined in blue indicates the DC output terminals (TB501, TB502). Connect the Neutral (N) side of the AC stabilized power supply to pin2 of TB1, connect the Live(L) of the AC stabilized power supply to pin1 of TB1. If necessary, connect the Earth (frame ground) to pin3 of TB1. Connect the positive side of the DC load to TB501, and the negative side to TB502. Please ensure that the power supply, load equipment, and cables used for connection meet the specifications of this power supply.



Fig. 4.2 External Connections

### 4.2. Start and Stop Procedures

Before starting the power supply, check that the input and output pin voltages are all 0V.

[Starting Procedure]

1. Turn on the AC stabilized power supply.

[Stopping Procedure]

1. Turn off the AC stabilized power supply.

### 4.3. Evaluation Precautions (Electric Shock, Burn Injury, etc.)

Be careful of electric shock when connecting a stabilized power supply. Do not touch each part of the power supply directly while the power is on. Be very careful when observing the waveform. Even after this power supply is stopped, there is a risk of electric shock due to the remained charge of various capacitors. Confirm that the voltage of each part has decreased sufficiently before touching the board.

In addition, the semiconductor or inductor of this power supply generates heat according to the load current. Do not touch each part of the power supply while the power supply is in operation, as there is a risk of burns.

## 5. Power Characteristics

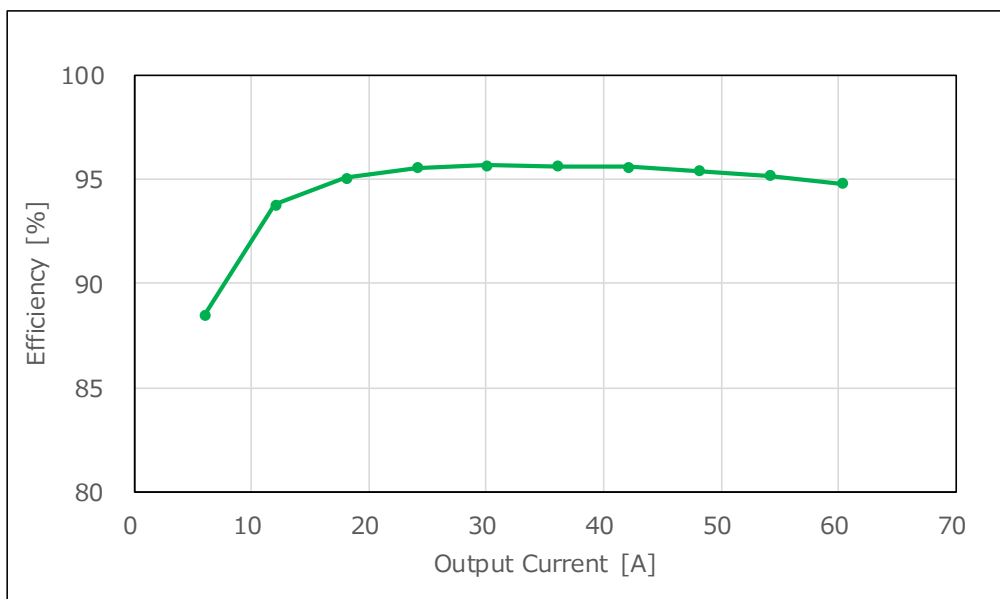
The power supply efficiency measurement results of this design are described below.

### 5.1. Efficiency

The power supply efficiency measurement results of this design are shown below. Measurements were conducted with the output voltage of the AC stabilized power supply set to 230V.

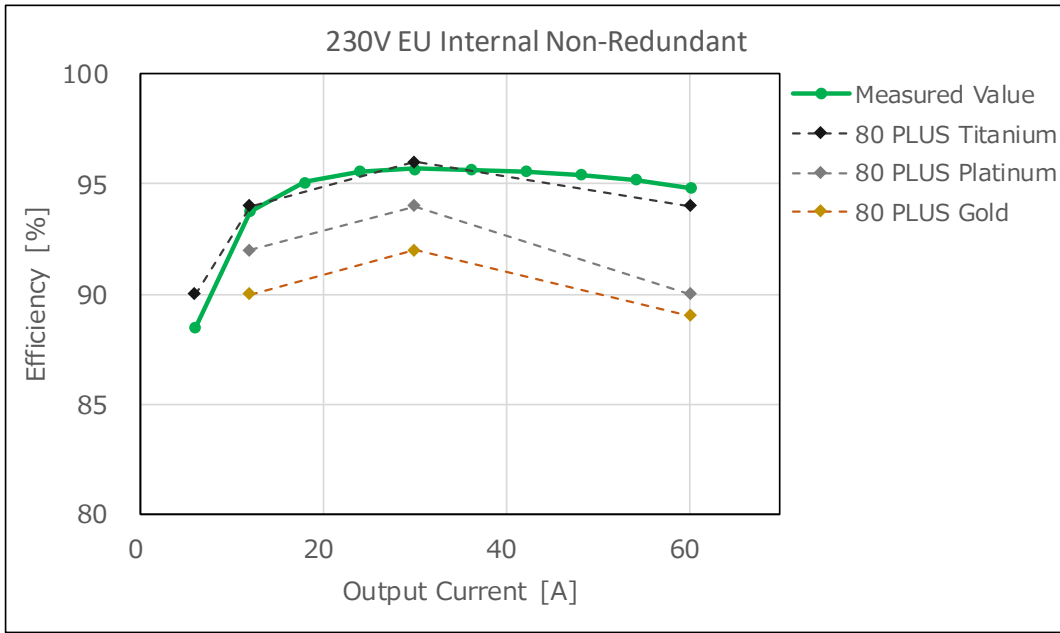
Fig. 5.1 shows the results when the AC stabilized power supply is set to 230V. At 100% load power, this design achieves high efficiency of 94.8%.

The efficiency measurement at this time is performed with the cooling FAN driven by an external power supply. The measurement result changes when the cooling FAN is driven by the internal power supply. In addition, this design equipped with the ORing circuit at the output section. When ORing circuit is removed, the power supply efficiency of this design will be improved.

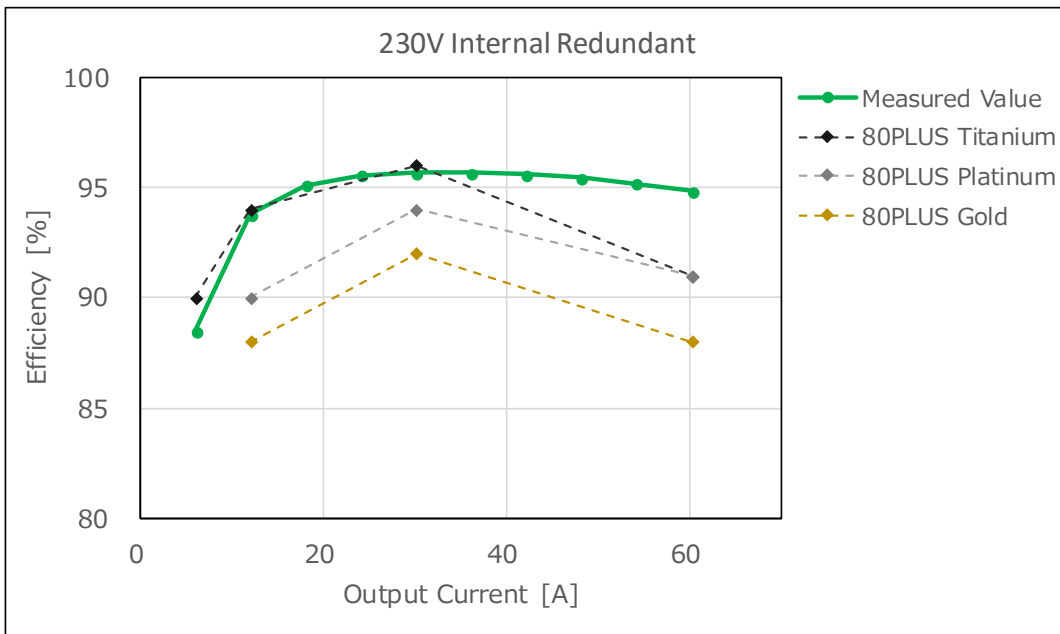


**Fig. 5.1 Efficiency Measurement Results (V<sub>in</sub> = 230V)**

For reference, Fig. 5.2 to Fig. 5.3 show the measurement efficiency of this design and the standard of 80 PLUS. It is confirmed that the efficiency of this design in V<sub>in</sub> = 230V meets Platinum standard. The 80 PLUS standards in the chart are as of September 2025. The standard values may be updated. Please check them every time. This design is not certified for 80 PLUS. It is necessary to measure the power supply efficiency using the equipment that will be the final product and acquire the certification.



**Fig.5.2 Efficiency Measurement Result (80 PLUS 230V EU Internal Non-Redundant)**



**Fig.5.3 Efficiency Measurement Result (80 PLUS 230V Internal Redundant)**

## Terms of Use

This terms of use is made between Toshiba Electronic Devices and Storage Corporation ("We") and Customer who downloads or uses this Reference Design. Customer shall comply with this terms of use. This Reference Design means all documents and data in order to design electronics applications on which our semiconductor device is embedded.

### **Section 1. Restrictions on usage**

1. This Reference Design is provided solely as reference data for designing electronics applications. Customer shall not use this Reference Design for any other purpose, including without limitation, verification of reliability.
2. Customer shall not use this Reference Design for sale, lease or other transfer.
3. Customer shall not use this Reference Design for evaluation in high or low temperature, high humidity, or high electromagnetic environments.
4. This Reference Design shall not be used for or incorporated into any product or system whose manufacture, use, or sale is prohibited under any applicable laws or regulations.

### **Section 2. Limitations**

1. We reserve the right to make changes to this Reference Design without notice.
2. This Reference Design should be treated as a reference only. WE ARE NOT RESPONSIBLE FOR ANY INCORRECT OR INCOMPLETE DATA AND INFORMATION.
3. Semiconductor devices can malfunction or fail. When designing electronics applications by referring to this Reference Design, Customer is responsible for complying with safety standards and for providing adequate designs and safeguards for their hardware, software and systems which minimize risk and avoid situations in which a malfunction or failure of semiconductor devices could cause loss of human life, bodily injury or damage to property, including data loss or corruption. Customer must also refer to and comply with the latest versions of all relevant our information, including without limitation, specifications, data sheets and application notes for semiconductor devices, as well as the precautions and conditions set forth in the "Semiconductor Reliability Handbook".
4. Designing electronics applications by referring to this Reference Design, Customer must evaluate the whole system sufficiently. Customer is solely responsible for applying this Reference Design to Customer's own product design or applications. WE ASSUME NO LIABILITY FOR CUSTOMER'S PRODUCT DESIGN OR APPLICATIONS.
5. WE SHALL NOT BE RESPONSIBLE FOR ANY INFRINGEMENT OF PATENTS OR ANY OTHER INTELLECTUAL PROPERTY RIGHTS OF THIRD PARTIES THAT MAY RESULT FROM THE USE OF THIS REFERENCE DESIGN. NO LICENSE TO ANY INTELLECTUAL PROPERTY RIGHT IS GRANTED BY THIS TERMS OF USE, WHETHER EXPRESS OR IMPLIED, BY ESTOPPEL OR OTHERWISE.
6. THIS REFERENCE DESIGN IS PROVIDED "AS IS". WE (a) ASSUME NO LIABILITY WHATSOEVER, INCLUDING WITHOUT LIMITATION, INDIRECT, CONSEQUENTIAL, SPECIAL, OR INCIDENTAL DAMAGES OR LOSS, INCLUDING WITHOUT LIMITATION, LOSS OF PROFITS, LOSS OF OPPORTUNITIES, BUSINESS INTERRUPTION AND LOSS OF DATA, AND (b) DISCLAIM ANY AND ALL EXPRESS OR IMPLIED WARRANTIES AND CONDITIONS RELATED TO THIS REFERENCE DESIGN, INCLUDING WITHOUT LIMITATION, WARRANTIES OR CONDITIONS OF FUNCTION AND WORKING, WARRANTIES OF MERCHANTABILITY, FITNESS FOR A PARTICULAR PURPOSE, ACCURACY OF INFORMATION, OR NONINFRINGEMENT.

### **Section 3. Terms and Termination**

It is assumed that Customer agrees to any and all this terms of use if Customer downloads or uses this Reference Design. We may, at its sole and exclusive discretion, change, alter, modify, add, and/or remove any part of this terms of use at any time without any prior notice. We may terminate this terms of use at any time and without any cause. Upon termination of this terms of use, Customer shall eliminate this Reference Design. Furthermore, upon our request, Customer shall submit to us a written confirmation to prove elimination of this Reference Design.

### **Section 4. Export Control**

Customer shall not use or otherwise make available this Reference Design for any military purposes, including without limitation, for the design, development, use, stockpiling or manufacturing of nuclear, chemical, or biological weapons or missile technology products (mass destruction weapons). This Reference Design may be controlled under the applicable export laws and regulations including, without limitation, the Japanese Foreign Exchange and Foreign Trade Act and the U.S. Export Administration Regulations. Export and re-export of this Reference Design is strictly prohibited except in compliance with all applicable export laws and regulations.

### **Section 5. Governing Laws**

This terms of use shall be governed and construed by laws of Japan, without reference to conflict of law principle.

### **Section 6. Jurisdiction**

Unless otherwise specified, Tokyo District Court in Tokyo, Japan shall be exclusively the court of first jurisdiction for all disputes under this terms of use.