

Toshiba CMOS Linear Integrated Circuit Silicon Monolithic

TCKE6 Series

40 V, 2.5 A eFuse IC with Adjustable Overcurrent Protection

Description

TCKE6xx series are Single Input-Single Output eFuse ICs with maximum operating voltage of 30V. It can be used as a reusable fuse, and includes protection features like adjustable over current limit by an external resistor, short circuit protection, over voltage protection, under voltage protection, and thermal shutdown. Switch ON resistance is only 52 m Ω (typ.), and the output current is up to 2.5 A and wide input voltage operation characteristics make this series ideal for 24 V power management.

This series is available in small package TSOP6F (2.9 mm x 2.8mm (typ.) and t: 0.8 mm (typ.)). Thus, this series is ideal for various applications such as industrial equipment and home appliances, etc.

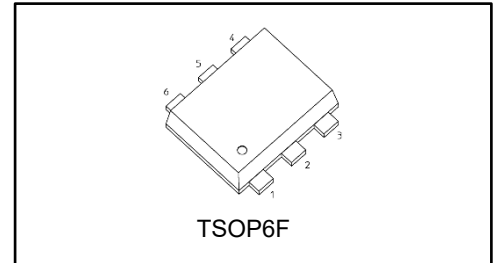

Weight: 15 mg (typ.)

Features

- Maximum input voltage: $V_{IN}(\max) = 40\text{ V}$
- Input voltage range: 4.4 V to 30 V
- Low ON resistance: $R_{ON} = 52\text{ m}\Omega$ (typ.)
- Adjustable overcurrent protection: 0.35 A to 2.4 A (Overcurrent limit)
- Over voltage protection ($V_{IN_OVLO} = 32\text{ V}$ (typ.))
- Slew rate control
- Thermal shutdown
- FLAG function: TCKE601
- MODE (Selectable recovery mode): TCKE602
- Enable function: TCKE603
- Output discharge
- Small package: TSOP6F (2.9 mm x 2.8 mm (typ.), t: 0.8 mm (typ.))

Notice

This series is sensitive to electrostatic discharge. Please ensure the equipment and tools are adequately earthed when handling.

Start of commercial production
2025-09

1. Absolute Maximum Rating (Note) (Ta = 25°C)

Table 1.1 Absolute Maximum Rating

Characteristics	Symbol	Rating	Unit
Input voltage	V _{IN}	-0.3 to 40	V
ILIM voltage	V _{ILIM}	-0.3 to 6.0	V
Control voltage	V _{EN}	-0.3 to 6.0	V
Mode terminal voltage	V _{MODE}	-0.3 to 6.0	V
Output voltage	V _{OUT}	-0.3 to V _{IN} + 0.3 or 40 V, whichever is smaller	V
FLAG voltage	V _{FLAG}	-0.3 to 6	V
FLAG sink current	I _{FLAG}	0 to 10	mA
Power dissipation (Note1)	P _D	0.9	W
Junction temperature	T _j	150	°C
Storage temperature	T _{stg}	-55 to 150	°C

Note: Using continuously under heavy loads (e.g. the application of high temperature/current/voltage and significant change in temperature, etc.) may cause this product to decrease in reliability significantly even if the operating conditions (i.e. operating temperature/current/voltage, etc.) are within the absolute maximum ratings. Please design the appropriate reliability upon reviewing the Toshiba Semiconductor Reliability Handbook (“Handling Precautions”/“Derating Concept and Methods”) and individual reliability data (i.e. reliability test report and estimated failure rate, etc).

Note1: Rating at mounting on a board: FR4 board. (76.2mm x 114.3mm x 1.6mm, 4 layer)

2. Operating range

Table 2.1 Operating range

Characteristics	Symbol	Ranges (Note 2)		Unit
Input voltage	V _{IN}	4.4 to 30		V
Output current	I _{OUT}	DC	0 to 2.5	A
ILIM external resistance	R _{ILIM}	11 to 53.6		kΩ
Control voltage	V _{EN}	0 to 5.5		V
Mode terminal voltage	V _{MODE}	0 to 5.5		V
FLAG voltage	V _{FLAG}	0 to 5.5		V
FLAG sink current	I _{FLAG}	0 to 10		mA
Operating junction temperature	T _{j_opr}	-40 to 125		°C

Note2: Do not operate at or near the maximum ratings of operating ranges for extended periods of time. Exposure to such conditions may adversely impact reliability and results in failure not covered by warranty. Maximum output current of operating ranges tables is defined as lifetime average junction temperature of 107°C where maximum output current lifetime average current to avoid electro migrating.

3. Pin Assignments (Top View)

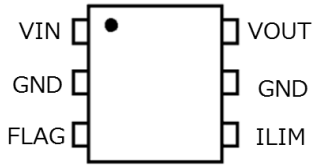

Figure 3.1 Pin Assignments
TCKE601RA,TCKE601RL

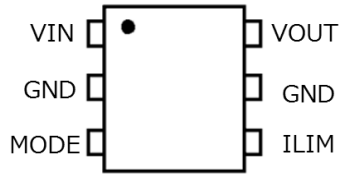

Figure 3.2 Pin Assignments
TCKE602RM

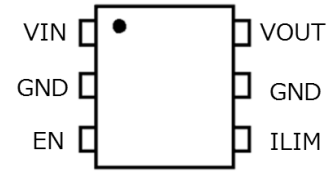

Figure 3.3 Pin Assignments
TCKE603RA,TCKE603RL

4. Top Marking (Top view)

Example: TCKE601RA

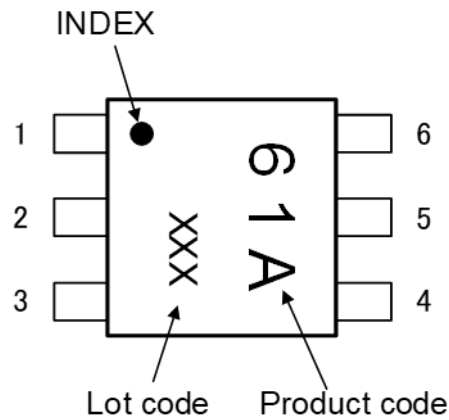

Figure 4.1 Marking

4.1. Product list

Table 4.1 Product list

Product name	Function	Fault Response	Top Marking
TCKE601RA	FLAG	Auto-retry	61A
TCKE601RL	FLAG	Latched	61L
TCKE602RM	MODE	Selection type	62M
TCKE603RA	EN	Auto-retry	63A
TCKE603RL	EN	Latched	63L

5. Pin Description

Table 5.1 Pin Description

PIN Name	Description
EN	Enable input. Active high. This function turns on the output as an enable signal.
ILIM	Current limit set input. A resistor between ILIM terminal and GND sets the current limit. Please do not apply external voltage
FLAG	Open drain signal output. Outputs the status of a specific protection operation.
MODE	MODE switching. The fault response is auto-retry type at high input. When the input is low or open, the fault response is latch type.
VIN	Supply input. Input the power switch and the supply voltage for the device.
GND	Ground
VOUT	Output. Output of the power switch.

6. Operation Logic Table

Table 6.1 Operation Logic Table

TCKE601RA, TCKE601RL, TCKE602RM (Ta = -40 to 125°C)

	$V_{IN} \leq V_{IN_UVLO}$ (Note 3)	$V_{IN_UVLO} < V_{IN} < V_{IN_OVLO}$	$V_{IN_OVLO} \leq V_{IN}$ (Note 4)
Output	OFF	ON	OFF

TCKE603RA, TCKE603RL (Ta = -40 to 125°C)

	$V_{IN} \leq V_{IN_UVLO}$ (Note 3)	$V_{IN_UVLO} < V_{IN} < V_{IN_OVLO}$	$V_{IN_OVLO} \leq V_{IN}$ (Note 4)
Output	EN = Low level	OFF	OFF
	EN = High level	OFF	ON

Note3: The UVLO threshold has hysteresis, so please refer to the operation description for details.

Note4: The OVLO threshold has hysteresis, so please refer to the operation description for details.

7. Block Diagram

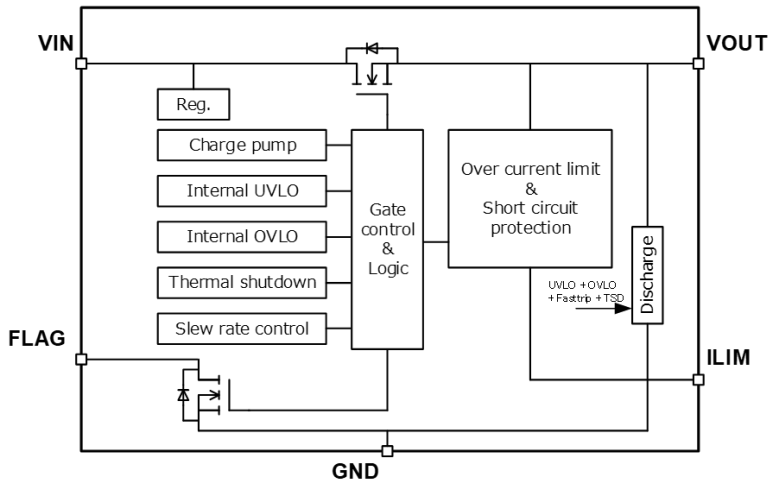

**Figure 7.1 Block Diagram
TCKE601RA,TCKE601RL**

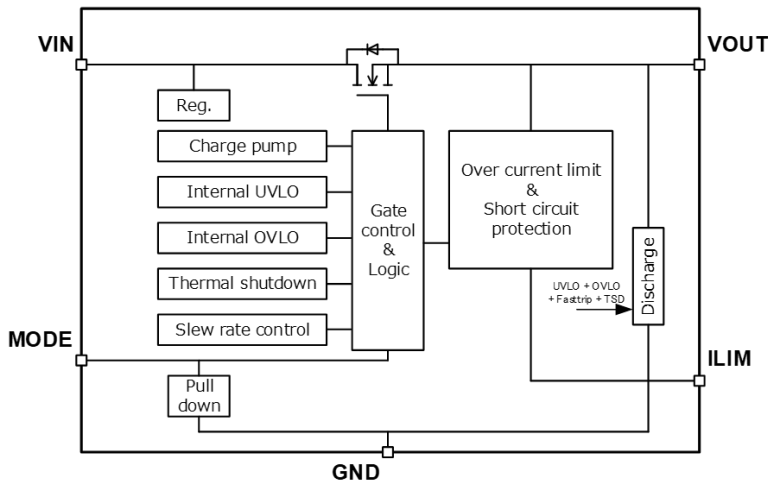

**Figure 7.2 Block Diagram
TCKE602RM**

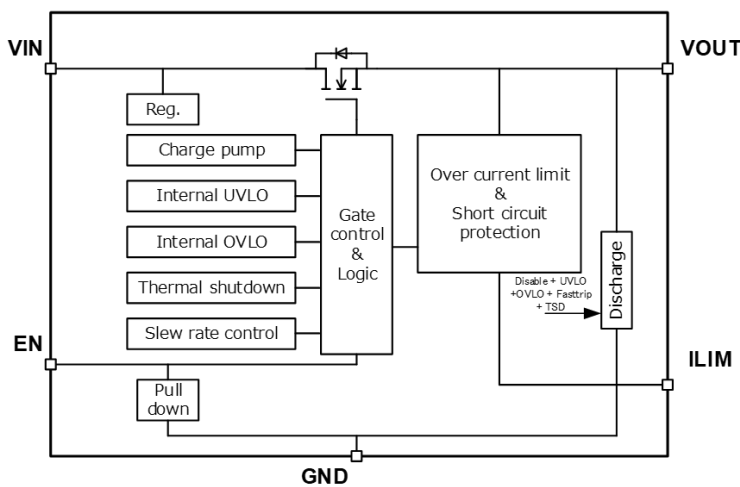

**Figure 7.3 Block Diagram
TCKE603RA,TCKE603RL**

8. Electrical Characteristics

8.1. DC Characteristics

Table 8.1.1 DC Characteristics

(Unless otherwise specified, Ta = 25°C, V_{IN} = 24 V)

Characteristics	Symbol	Test Condition	Ta= 25°C			Ta= -40 to 125°C (Note5)		Unit
			Min	Typ.	Max	Min	Max	
Basic operation								
V _{IN} under voltage lockout (UVLO) threshold, rising	V _{IN_UVLO}	—	—	4.0	—	3.6	4.4	V
V _{IN} under voltage lockout (UVLO) hysteresis	V _{IN_UVhys}	—	—	0.13	—	—	—	V
V _{IN} over voltage lockout (OVLO) threshold, rising	V _{IN_OVLO}	—	—	32.0	—	30.0	34.0	V
V _{IN} over voltage lockout (OVLO) hysteresis	V _{IN_OVhys}	—	—	0.9	—	—	—	V
EN threshold voltage, rising	V _{ENR}	TCKE603 Only	—	0.83	—	0.45	1.10	V
EN threshold voltage, falling	V _{ENF}	TCKE603 Only	—	0.78	—	0.4	1.05	V
EN pull down resistance	R _{EN}	TCKE603 Only	—	400	—	220	800	kΩ
On resistance (Note6)	R _{ON}	I _{OUT} = 1.0 A R _{LIM} = 11 kΩ	—	52	—	—	90	mΩ
Quiescent current (ON state)	I _Q	I _{OUT} = 0 A TCKE603: V _{EN} = 3 V, R _{LIM} = 11 kΩ	—	1000	—	—	1200	μA
Quiescent current (OFF status)	I _{Q(OFF)}	TCKE603 Only V _{EN} = 0V	—	5.2	—	—	7.5	μA
Discharge resistance	R _{DIS}	V _{OUT} = 24 V	—	2.3	—	1.1	4.6	kΩ
FLAG								
FLAG pin resistance	R _{FLAG}	TCKE601 Only L Level	—	11	—	—	—	Ω
FLAG leak current	I _{FLAG}	TCKE601 Only V _{FLAG} =5.5 V	—	—	—	—	1	μA
Overcurrent protection								
Output limit current (Note6,7)	I _{LIM}	R _{LIM} = 11 kΩ, V _{IN} - V _{OUT} = 2 V	—	2.40	—	1.84	2.98	A
		R _{LIM} = 23.7 kΩ, V _{IN} - V _{OUT} = 2 V	—	0.98	—	0.65	1.36	
		R _{LIM} = 53.6 kΩ, V _{IN} - V _{OUT} = 2 V	—	0.35	—	0.18	0.57	
		R _{LIM} = OPEN, V _{IN} - V _{OUT} = 2 V	—	0.06	—	—	—	
Output detection current (Note6,7)	I _{LIMP}	R _{LIM} = 11 kΩ,	—	2.70	—	2.06	3.26	A
		R _{LIM} = 23.7 kΩ,	—	1.28	—	0.90	1.72	
		R _{LIM} = 53.6 kΩ,	—	0.58	—	0.32	0.96	
		R _{LIM} = OPEN	—	0.19	—	—	—	
Fast trip comparator level	I _{FASTTRIP}	R _{LIM} = 11 kΩ	—	I _{LIM} × 1.9	—	—	—	A

8.1. DC Characteristics

Table 8.1.2 DC Characteristics

(Unless otherwise specified, $T_a = 25^\circ\text{C}$, $V_{IN} = 24\text{ V}$)

Characteristics	Symbol	Test Condition	$T_a = 25^\circ\text{C}$			$T_a = -40\text{ to }125^\circ\text{C}$ (Note5)		Unit
			Min	Typ.	Max	Min	Max	
Thermal Protection								
Thermal shutdown threshold	T_{SD}	T_j	—	155	—	—	—	$^\circ\text{C}$
Thermal shutdown hysteresis	T_{SDH}	T_j	—	15	—	—	—	$^\circ\text{C}$
Thermal shutdown auto-retry interval time	$t_{TSD, RST}$	Only Auto retry type	—	100	—	—	—	ms
MODE								
MODE switching threshold voltage, rising	V_{MODER}	TCKE602 Only	—	0.81	—	0.45	1.10	V
MODE switching threshold voltage, falling	V_{MODEF}	TCKE602 Only	—	0.76	—	0.4	1.05	V
MODE pin pull down resistance	R_{MODE}	TCKE602 Only	—	440	—	220	800	$\text{k}\Omega$

Note5: This parameter is warranted by design.

Note6: The measurements are taken using pulse measurement to ensure that the junction temperature and ambient temperature are almost equal

Note7: The figure below is a reference diagram of the output voltage and current during output current limiting operation.

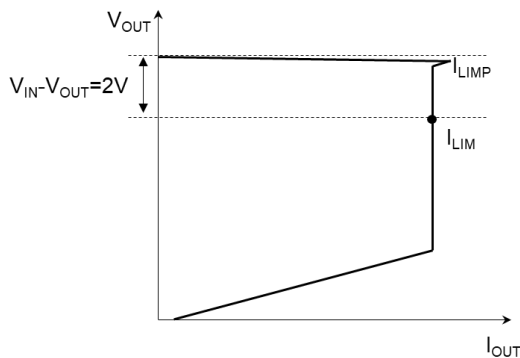

Figure 8.1.1 Reference diagram

8.2. AC Characteristics

Table 8.2.1 AC Characteristics

(Unless otherwise specified, $T_a = 25^\circ\text{C}$, $R_{LIM} = 11\text{ k}\Omega$, $R_{LOAD} = 100\ \Omega$, $C_{IN} = C_{OUT} = 1\ \mu\text{F}$)

Characteristics	Symbol	Test Condition	Min	Typ.	Max	Unit
Short circuit response time	t_{SHORT}	R_{LOAD} : Open to $0\ \Omega$	—	1	—	μs
Current limit response time	t_{LIM}	R_{LOAD} : Open to $8\ \Omega$	—	30	—	μs
Turn on delay	t_{D_ON}	$V_{IN} = 24\ \text{V}$, TCKE601, 602: V_{IN_UVLO} to V_{OUT} 10% TCKE603: V_{ENR} to V_{OUT} 10%	—	630	—	μs
Turn off delay	t_{OFF}	$V_{IN} = 24\ \text{V}$, TCKE603 Only	—	6	—	μs
V_{OUT} rise time	t_r	$V_{IN} = 24\ \text{V}$, V_{OUT} 10% to 90%	—	150	—	μs
Output Rising Slew Rate	SR_{on}	$V_{IN} = 24\ \text{V}$	—	128	—	V/ms

AC Waveform

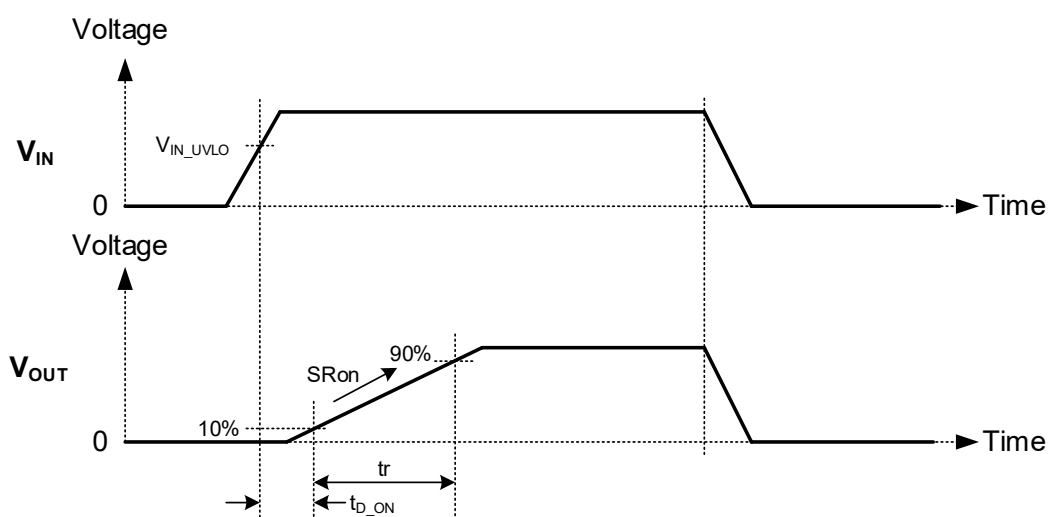

Figure 8.2.1 AC Waveform TCKE601, TCKE602

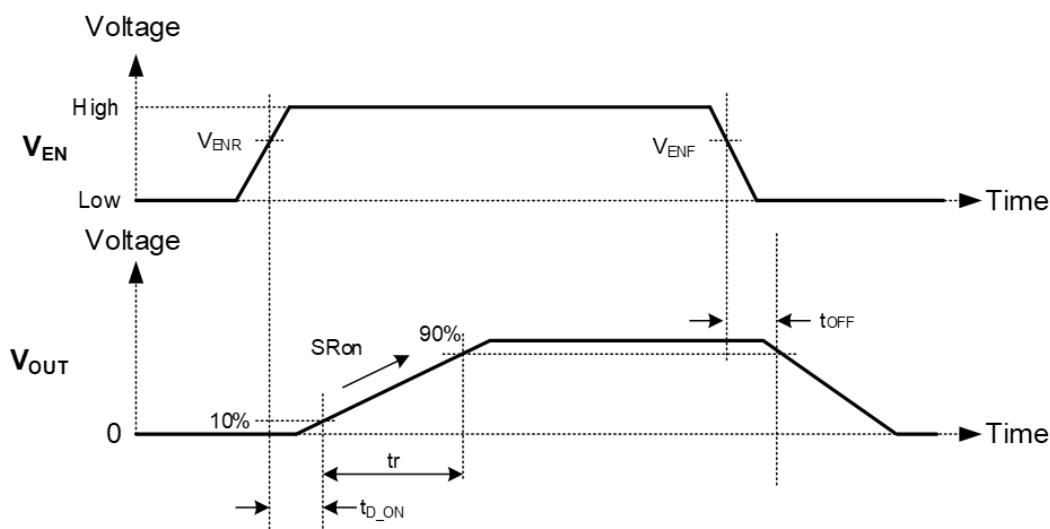

Figure 8.2.2 AC Waveform TCKE603

9. Operation Description

9.1. Precautions during IC startup

When using this product with non-capacitive loads during startup, please pay attention to the following points.

- When starting up this IC, ensure that the load current is below the current limit (I_{LIM}).
- When T_a is below -10°C , ensure that V_{OUT} rises above 100 mV before allowing current to flow to bring up V_{OUT} .

9.2. Overcurrent limiting operation (OCL)

The overcurrent protection function reduces power consumption during abnormalities and prevents the destruction of the IC and the load. When the output current exceeds the output detection current I_{LIMP} due to load abnormalities or short circuits, it is limited to the output current limit I_{LIM} . Together with the short-circuit protection function described later, it provides double protection against overcurrent.

9.2.1. Auto-retry type overcurrent protection operation

When the output current reaches the output detection current I_{LIMP} and overcurrent is detected, the current is limited to prevent it from exceeding I_{LIM} . In this case, the output voltage decreases according to the relationship between output voltage and current. If the overcurrent condition is not resolved at this stage, the IC temperature will rise. If it reaches the overheat protection temperature, the output will stop, and the IC will transition to a shutdown state. After a certain period, the IC will restart. However, if the overcurrent condition persists, the current will be limited again. Therefore, the cycle of current limiting → temperature rises → overheat protection → shutdown → temperature decrease → restart → current limiting will repeat to recover. Additionally, there is a delay of approximately 60 μs (typ.) before the IC turns off and the FLAG pin outputs a Low level.

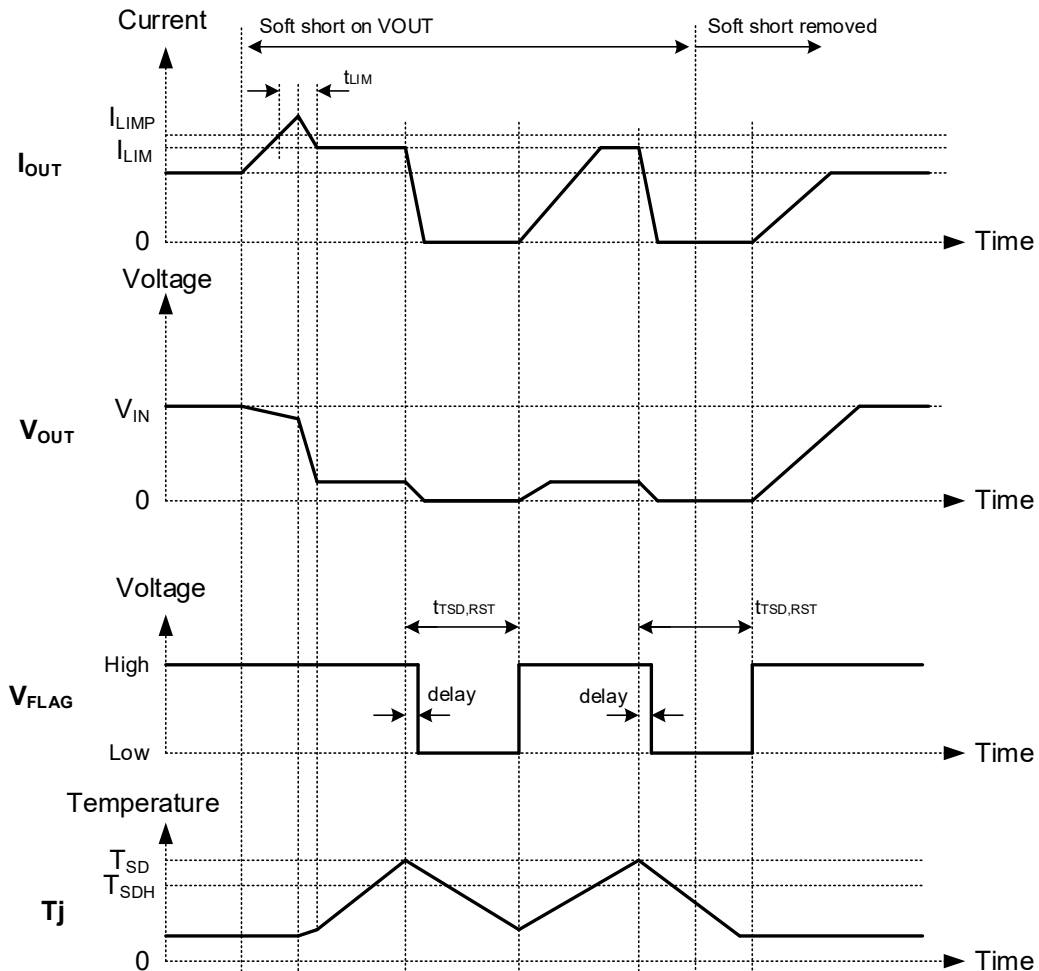

Figure 9.2.1.1 Timing chart for overcurrent protection operation (Auto-retry type)

9.2.2. Latch-type overcurrent protection operation

In the case of latch-type overcurrent protection, the protection operation latches during thermal protection. To reset, it is necessary to restart by reapplying a control signal to the EN pin or voltage to the VIN pin. The protection operation continues until the restart.

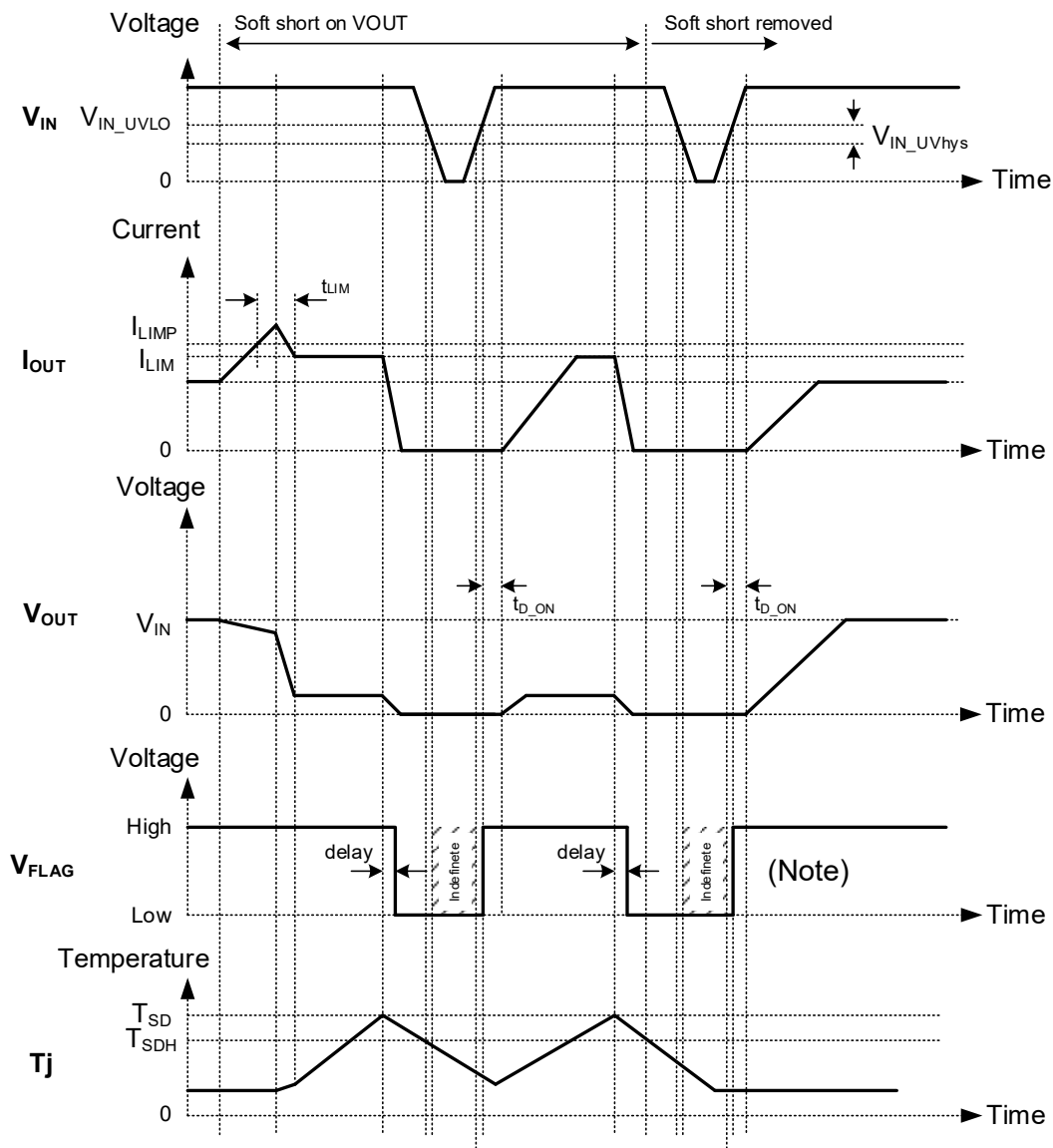

Figure 9.2.2.1 Timing chart for overcurrent protection operation (TCKE601RL)

Note: For details on FLAG output, please refer to the operation description.

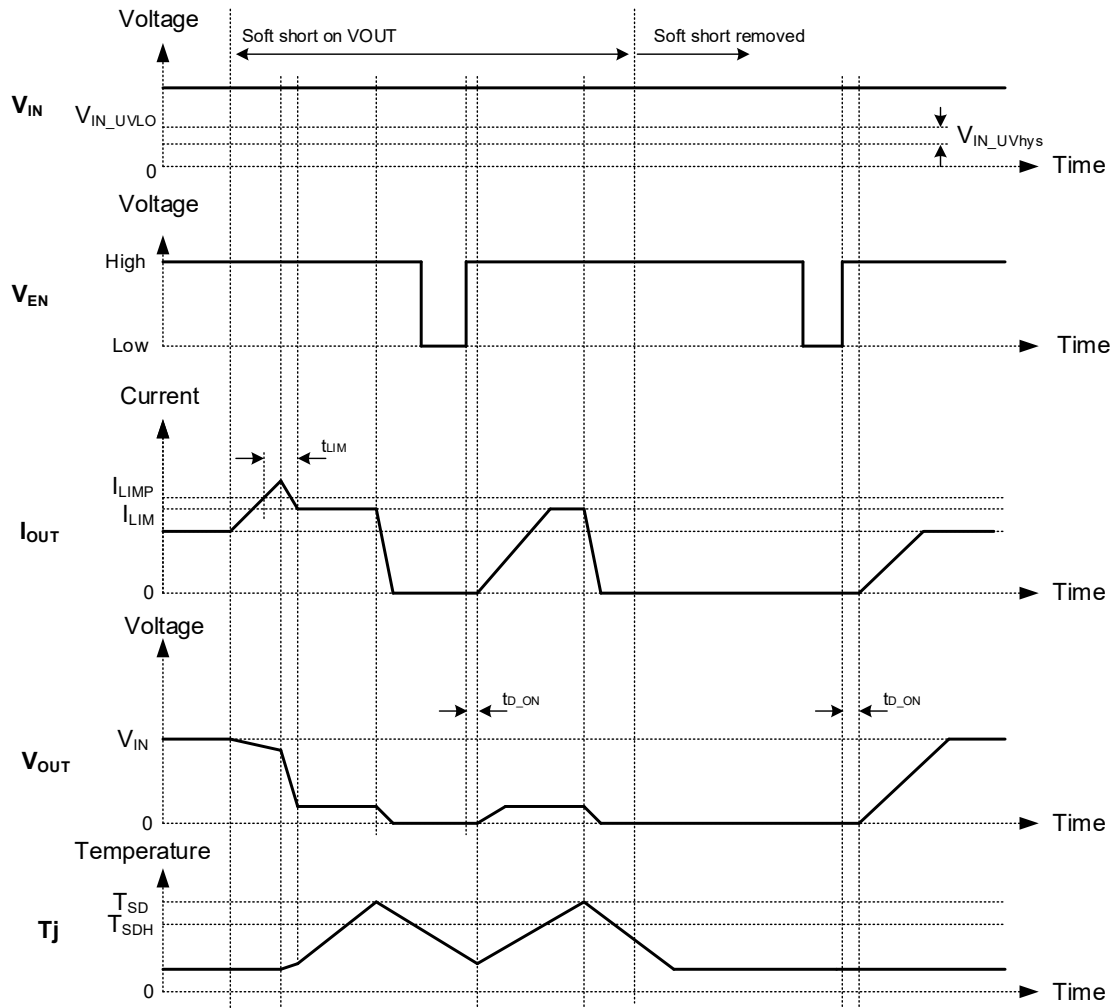

Figure 9.2.2.2 Timing chart for overcurrent protection operation (TCKE603RL)

9.2.3. Configuring the overcurrent protection feature

TCKE6 series has an adjustable the output detection current I_{LIMP} , and by appropriately selecting the external resistor R_{ILIM} for the ILIM pin, the output detection current can be set to the optimal value for the application. The calculation formula for I_{LIMP} is common to the TCKE6 series and is shown below. However, since the following is a theoretical formula, please be sure to verify the resistor value with the actual device. Also, please ensure that R_{ILIM} does not fall below 5 k Ω .

$$R_{ILIM} (\Omega) = \frac{29275}{I_{LIMP} (A) + 0.0374}$$

R_{ILIM} : External resistor for ILIM pin (Ω)

I_{LIMP} : Output limit current (A)

Below is the circuit diagram around the ILIM pin and the graph showing the relationship between R_{ILIM} and I_{LIMP} .

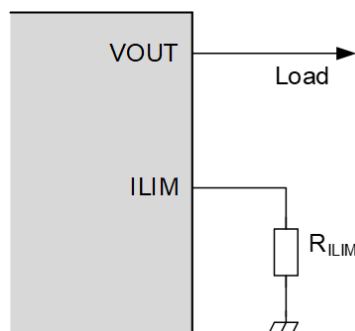

Figure 9.2.3.1 External Circuit Around the ILIM Pin

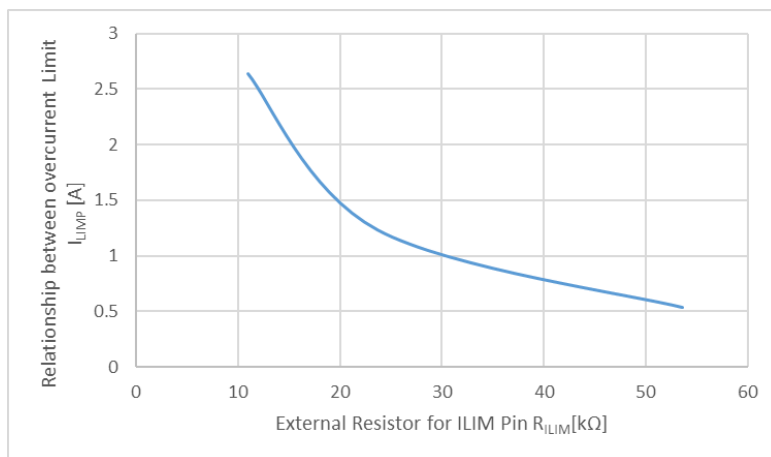

Figure 9.2.3.2 Relationship between overcurrent Limit (I_{LIMP}) and External Resistor for ILIM Pin R_{ILIM}

9.2.4. Open protection for ILIM Pin

When the ILIM pin is open, the output limit current is set to 60 mA (typ.).

9.2.5. Short-circuit protection for R_{ILIM} resistor

When the ILIM pin is shorted (below 5 k Ω), V_{OUT} remains in the OFF state.

9.3. Short-circuit protection operation for VOUT (Fast trip)

Short-circuit protection (Fast trip) is a function that stops operation when the power line or load is short-circuited due to some abnormality, preventing excessive current from flowing. In the TCKE6 series, if the output current exceeds 1.9 times (typ.) the output limit current I_{LIM} for a very short period, it is judged as a short circuit, and this function is activated.

9.3.1. Auto-retry type VOUT short-circuit protection operation

When the output current reaches 1.9 times the output limit current I_{LIM} , it is judged as a VOUT short circuit, and the output is stopped. After a certain period, it will start with a soft start, but if the VOUT voltage continues to be below the short-circuit judgement voltage (1.7 V (typ.)), it is determined to be a VOUT short-circuit and transitions to a shutdown state. After a certain period, the operation starts again, but if the VOUT short-circuit is not resolved, it will shut down again. The auto-retry type repeats this recovery attempt.

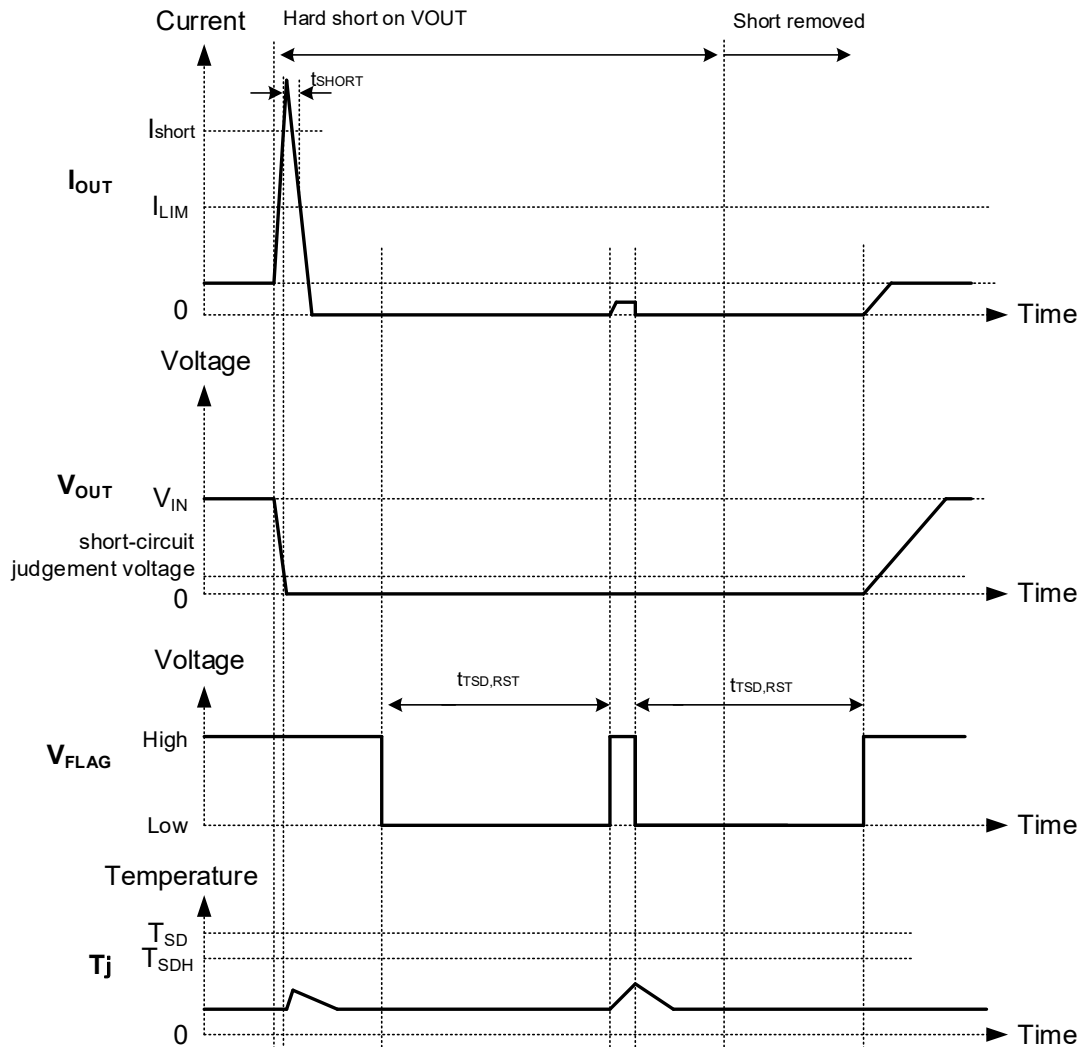

Figure 9.3.1.1 Timing chart of VOUT short circuit protection operation (auto retry type)

9.3.2. Latch type VOUT short circuit protection operation

When the output current reaches 1.9 times the output limit current I_{LIM} , it is judged as a VOUT short circuit, and the output is stopped. After a certain period, it will start with a soft start, but if the VOUT voltage continues to be below the short-circuit judgment voltage (1.7 V (typ.)), it is determined to be a VOUT short-circuit and transitions to a shutdown state. To recover, it is necessary to restart by either controlling the EN pin signal or reapplying VIN pin.

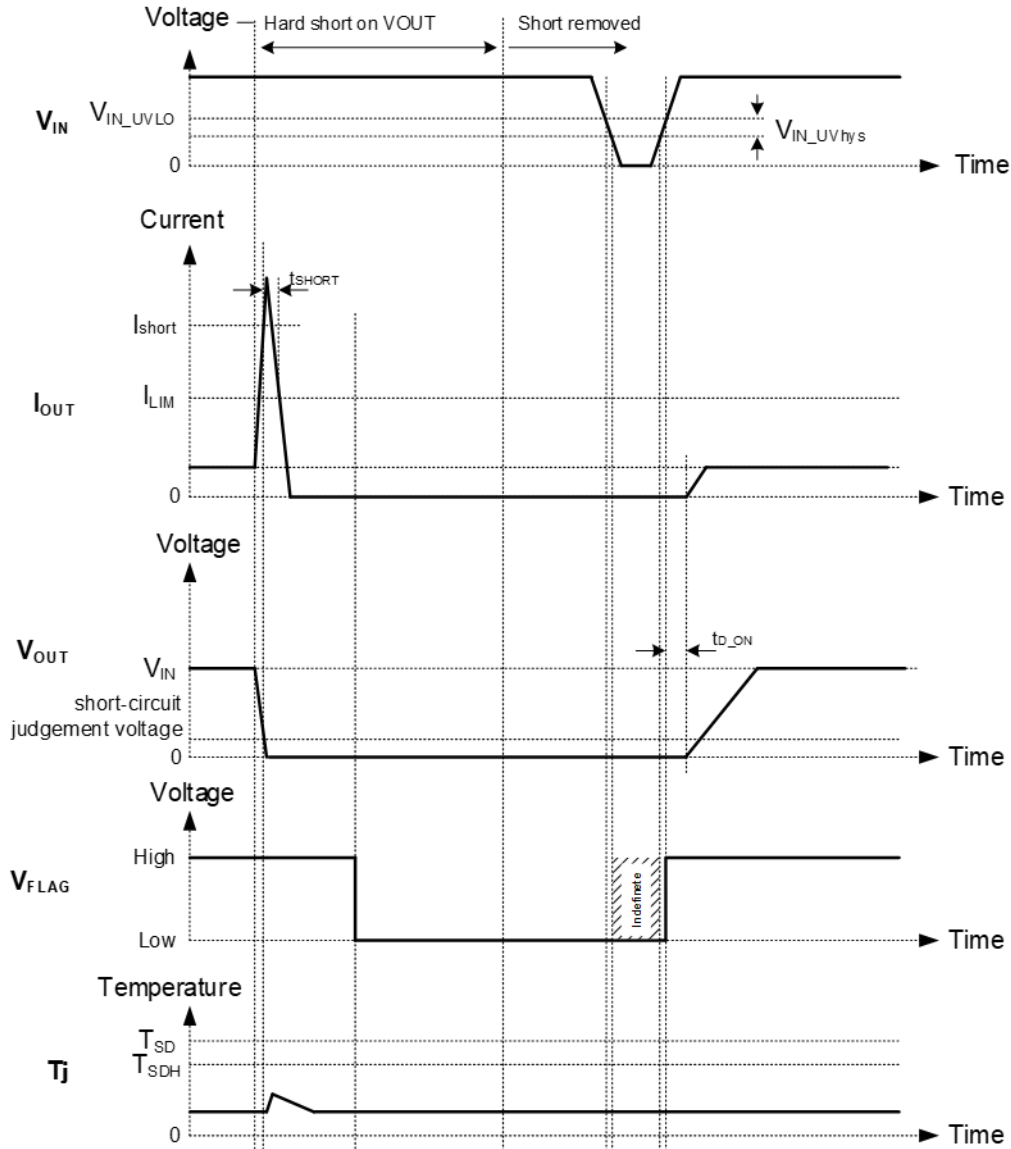

Figure 9.3.2.1 Timing chart of short circuit protection operation (TCKE601RL)

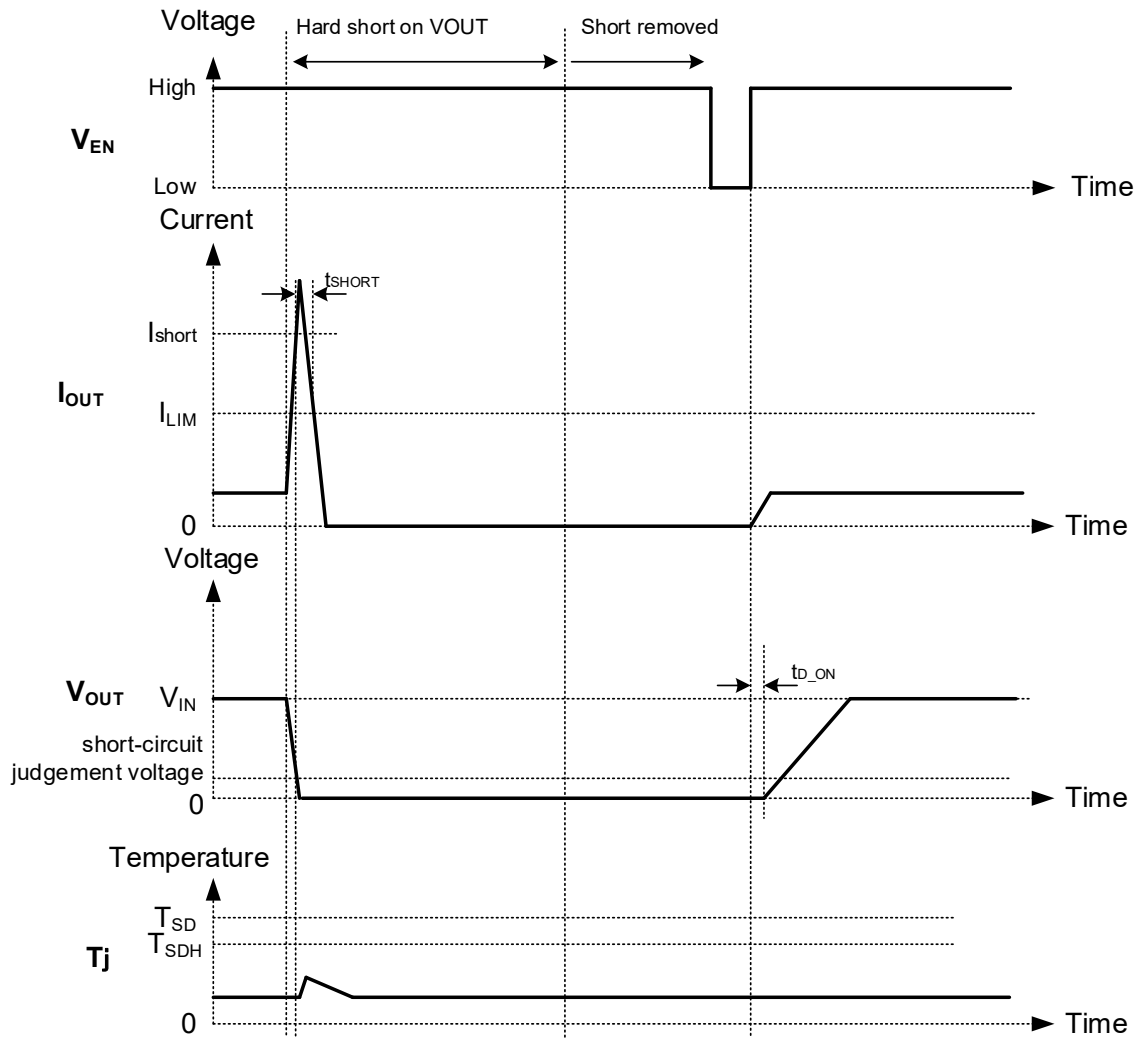

Figure 9.3.2.2 Timing chart of short circuit protection operation (TCKE603RL)

9.4. VIN Overvoltage lockout operation (OVLO)

Overvoltage lockout operation is a function that stops the output when the input voltage exceeds the OVLO voltage, preventing overvoltage from being applied to the load. When the input voltage V_{IN} exceeds a certain voltage, the IC operation stops. This voltage has hysteresis V_{IN_OVhys} during both rising and falling edges. Regardless of whether it is an auto-retry or latch type, the IC operation resumes when the voltage drops below a certain level.”

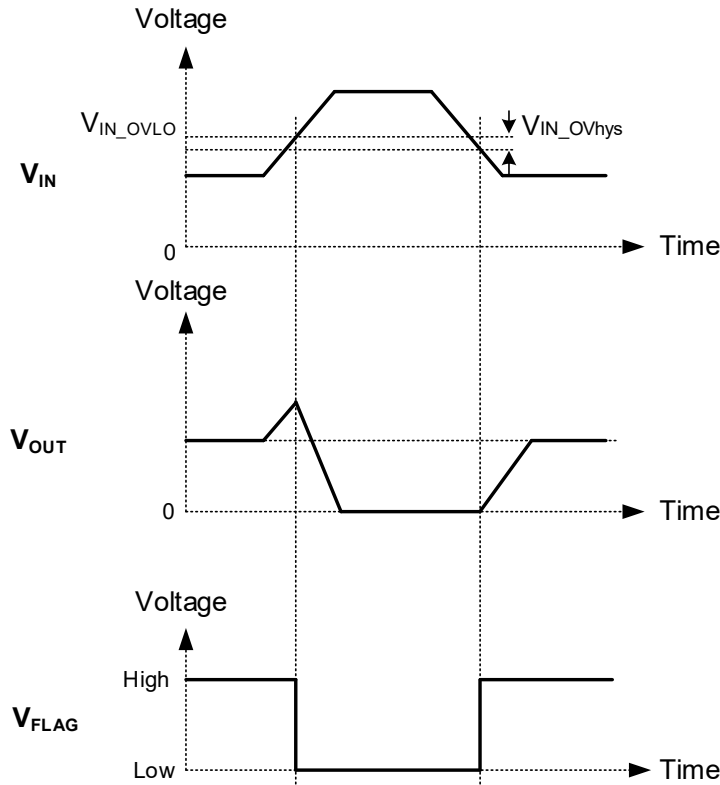

Figure 9.4.1 VIN Overvoltage lockout operation

9.5. Thermal shutdown operation (TSD)

The overheat protection function (thermal shutdown) stops the IC operation and transitions to a shutdown state when a large current continues to flow to the output and the junction temperature of the eFuse IC exceeds the set value. “The overheat protection operating temperature and recovery temperature have hysteresis. After a certain period, when the temperature drops to the recovery temperature, the auto-retry type returns to normal operation. If the overcurrent abnormality is not resolved, it will enter protection mode again and will repeatedly alternate between overheat protection and recovery. On the other hand, for the latching type, after the overheat protection function operates and transitions to a shutdown state, it is necessary to return to normal operation by either controlling the EN pin signal or reapplying V_{IN} .

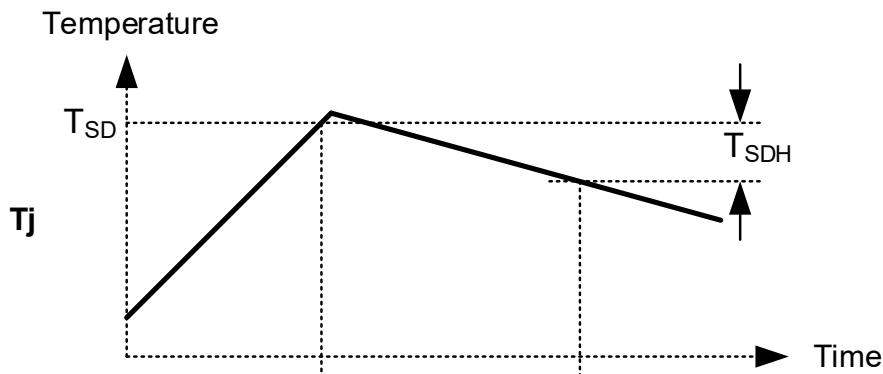

Figure 9.5.1 Thermal shutdown operation

9.6. Inrush current limiting function

When the output is turned on, inrush current flows to charge the capacitor connected to the load side. If this current is too large, the overcurrent protection circuit may malfunction, preventing startup, or causing an overshoot in the output voltage. To prevent this, this function controls the slew rate during the rise of the output voltage to suppress the inrush current. The figure below shows the rise of the output voltage V_{OUT} and the inrush current when the inrush current is suppressed by this function when $V_{IN} = 24\text{ V}$.

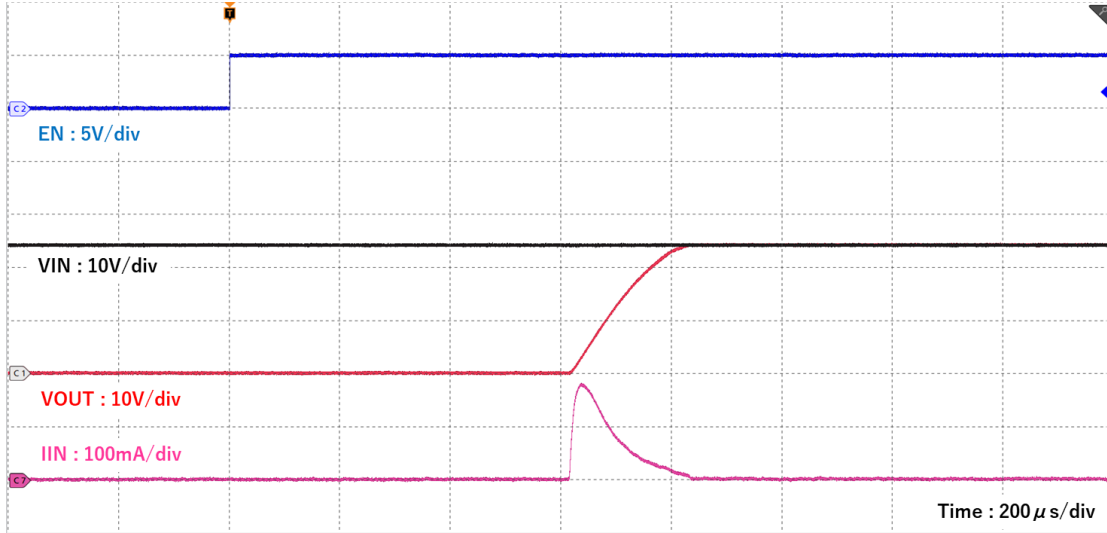

Figure 9.6.1 Waveform

9.7. VIN undervoltage malfunction prevention circuit (UVLO)

This function stops the operation of the eFuse IC during input undervoltage, preventing malfunction of ICs connected to the output side of the eFuse IC. The TCKE6 series starts operating at a certain input voltage (V_{IN}). This voltage has hysteresis (V_{IN_UVhys}) during both rising (V_{IN_UVLO}) and falling, and the operation stops when the voltage drops below a certain level.

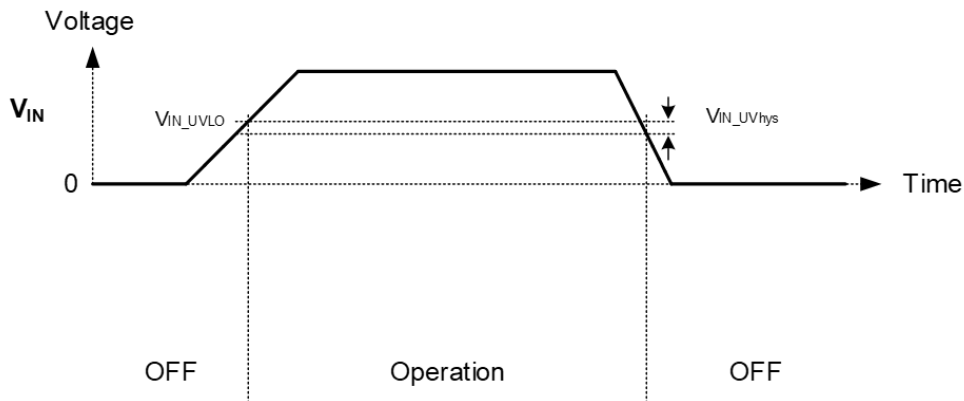
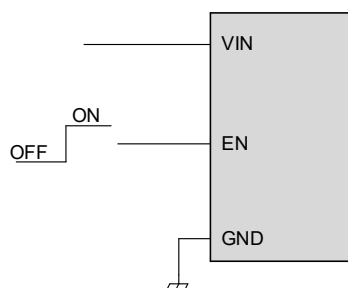

Figure 9.7.1 Waveform

9.8. EN operation

The TCKE603RL and TCKE603RA are equipped with an EN pin. You can control the overall operation of the eFuse IC using this pin. Below are examples of how to use this pin.

When controlling the operation externally.



Please input the control signal directly to the EN terminal from an external source. The EN terminal has hysteresis for the on/off threshold voltage, so set the control signal's high level to be at least 1.1 V and the low level to be 0.4 V or below. Additionally, when the EN terminal becomes open, the internal pull-down resistor R_{EN} of the IC controls the EN to a low level.

Figure 9.8.1 External Circuit Around the ILIM Pin

9.9. FLAG output function

When the TCKE601RA or TCKE601RL detects a specific abnormal condition, it outputs a low level on the FLAG terminal.

Table 9.9.1 FLAG output function

Failure mode	Symbol	IC Operation	FLAG output
Over temperature	TSD	Shutdown	Yes
V_{IN} Over voltage	OVLO	Shutdown	Yes
V_{IN} Under voltage	UVLO	Shutdown	Yes (Note7)
I_{OUT} Over current	OCL	I_{OUT} current limiting	—(Note8)
V_{OUT} Short circuit	Fast trip	Shutdown	Yes
ILM pin short	—	Shutdown	—

Note8: If the V_{IN} falls below the internal operating voltage (2.2 V (typ.)), the FLAG will no longer be output.

Note9: If the OCL (Over Current Limit) condition persists, the junction temperature of the IC will increase. If the junction temperature rises and reaches the temperature at which TSD (Thermal Shutdown) is triggered, the IC will shut down and output a FLAG.

9.10. MODE pin

TCKE602RM can change the return mode by switching the MODE pin. Please do not switch the MODE pin during IC operation.

9.11. Output discharge function

TCKE6 series has an internal discharge resistor R_{DIS} , which discharges the output capacitor when the IC is turned off. When the IC turns off, the internal discharge MOSFET turns on, bringing the output voltage to 0 V. Initially, the discharge MOSFET operates in the saturation region, performing constant current discharge. After that, when this MOSFET enters the linear region, it performs resistive discharge.

10. Application note

10.1. Peripheral circuit example

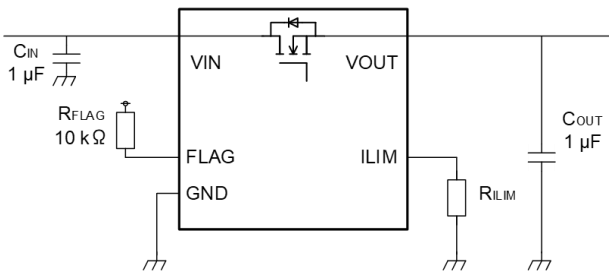

Figure 10.1.1
Peripheral circuit examples for TCKE601

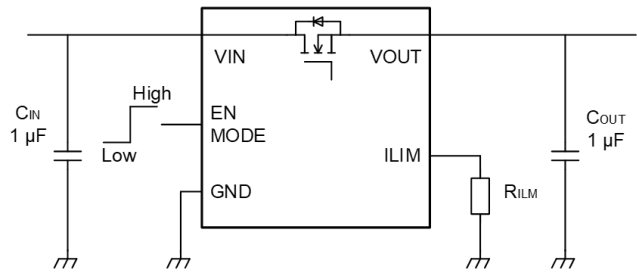

Figure 10.1.2
Peripheral circuit examples for TCKE602 and TCKE603

Peripheral circuits Connect the power supply to the VIN pin. During normal operation, almost the same voltage as the VIN voltage is output from the VOUT pin through the internal MOSFET. If the current suddenly decreases, for example, when short-circuiting or overcurrent is protected, high-spike voltages may be generated due to back electromotive force of inductance components such as wirings connected to the input/output pins of the eFuse IC, causing damage to the eFuse IC and resulting destruction. In this case, a positive spike voltage is generated on the input side and a negative spike voltage is generated on the output side. When designing boards, design patterns so that the length of the wires on the input-side and output-side of the eFuse IC is as short as possible. Also, the GND wiring area should be as wide as possible to reduce the impedance. C_{IN} functions to suppress the peak value against the positive spike voltage generated by the inputs. The peak value V_{SPIKE} of the spike voltage and the capacitance value of the C_{IN} have the following relationship. It can be understood that the spike voltage can be reduced by increasing C_{IN}.

$$V_{\text{SPIKE}} (\text{V}) = V_{\text{IN}} + I_{\text{OUT}} \times \sqrt{\frac{L_{\text{IN}}}{C_{\text{IN}}}}$$

L_{IN} : effective inductance component of the input pin (H)

I_{OUT} : output current (A)

V_{SPIKE} : peak value of spiked voltage generated (V)

V_{IN} : power supply voltage during normal operation (V)

C_{IN} is recommended to be 1 μF or more. Be sure to measure it on the actual PCB board.

If the VIN voltage is high, the VOUT voltage is also high, and the current change during short-circuit or overcurrent protection is large, causing unstable operation without stable V_{IN} and V_{OUT} and possibly leading to IC destruction.

If transient voltages exceeding the absolute maximum ratings are applied to the VIN pin, connect a TVS diode (ESD protection diode) or a Zener diode between the input pins and GND.

For negative spike voltages generated on the output side, such as during short-circuit protection operation, connect an SBD (Schottky barrier diode) between the output pin and GND. This will prevent output potential from dropping significantly below GND.

SBD is effective not only for protecting eFuse ICs, but also for protecting ICs and devices connected to the load side.

As noted above, TVS diode (Zener diode) and SBD are recommended for eFuse IC because they can provide more robust protective features. The diagram below shows the peripheral circuit diagram.

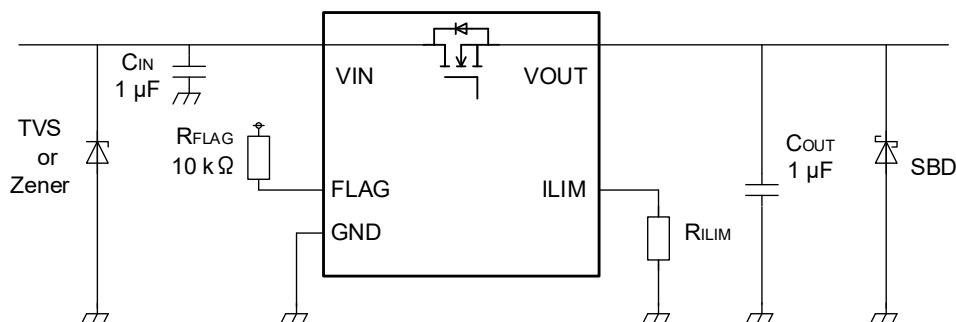

Figure 10.1.3 Peripheral circuit examples for TCKE601 (Add TVS and SBD)

10.2. allowable loss

Both unit and board-mounted power dissipation ratings for TCKE6 series are available on the Absolute Maximum Ratings table. Power dissipation is measured on the board shown below.

[The Board conditions]

FR4board: 76.2 mm × 114.3 mm × 1.6 mm (4layer)

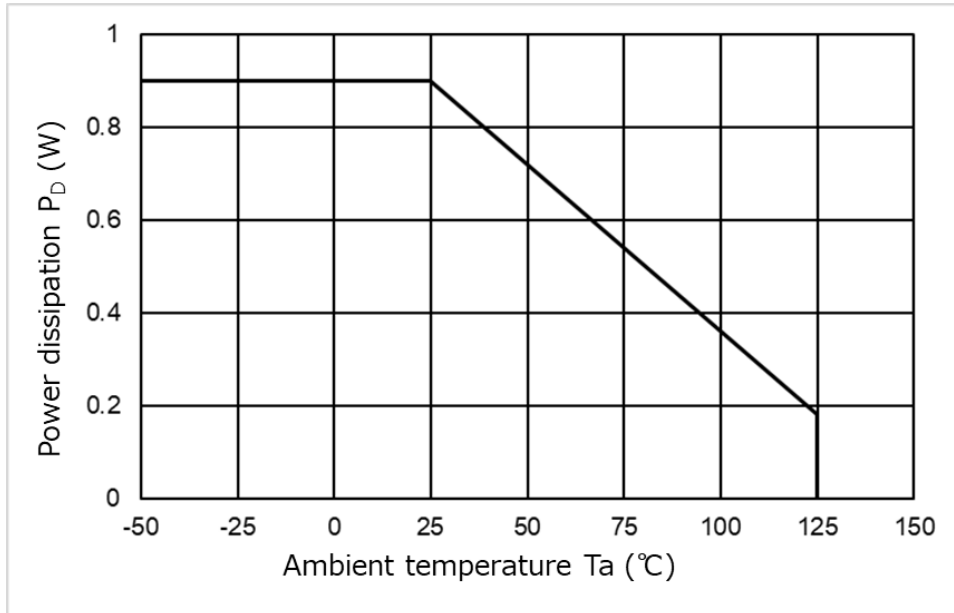

Figure 10.2.1 allowable loss

11. Attention in Use

- **Input/Output capacitors**
This product can use ceramic capacitors, but some types may have very large temperature characteristics. When selecting capacitors, please consider the usage environment carefully.
If the output capacitor is large, the overheat protection function of the IC may be activated by the heat generated by the inrush current, and the output may not start up.
- **Mounting**
The long distance between IC and output capacitors might affect phase assurance by impedance in wire and inductor. For stable power supply, output capacitors need to mount near IC as much as possible. Also, VIN and GND patterns need to be large and make the wire impedance small as possible.
- **Permissible Loss**
Please have enough design patterns for the expected maximum permissible loss. And under consideration of surrounding temperature, input voltage, and output current etc., we recommend proper dissipation ratings for maximum permissible loss; in general, maximum dissipation rating is 70 to 80 %.
- **Protection circuit**
Over current protection, over voltage protection and Thermal shut down function are designed in these products, but these are not designed to constantly ensure the suppression of the device within operation limits. Depending on the condition during actual usage, it could affect the electrical characteristic specification and reliability. Also note that if output pin and GND pin s are not completely shorted out, these products might break down.
When using these products, please read through and understand the concept of dissipation for absolute maximum ratings from the abovementioned or our 'Semiconductor Reliability Handbook'. Then use these products under absolute maximum ratings in any condition. Furthermore, Toshiba recommend inserting a failsafe system into the design.

12. Representative characteristics (Note)

Figure 12.1 Quiescent current (ON state) I_Q
 $V_{EN} = 3\text{ V}$, $R_{ILIM} = 11\text{ k}\Omega$, $I_{OUT} = 0\text{ A}$

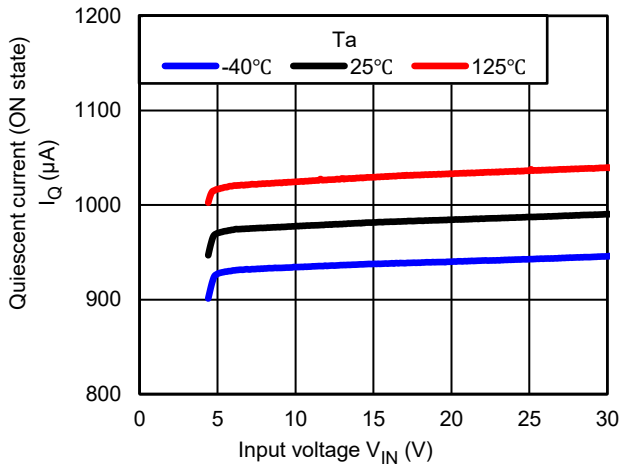

Figure 12.2 Quiescent current (OFF state) $I_{Q(OFF)}$
 $V_{EN} = 3\text{ V}$, $R_{ILIM} = 11\text{ k}\Omega$

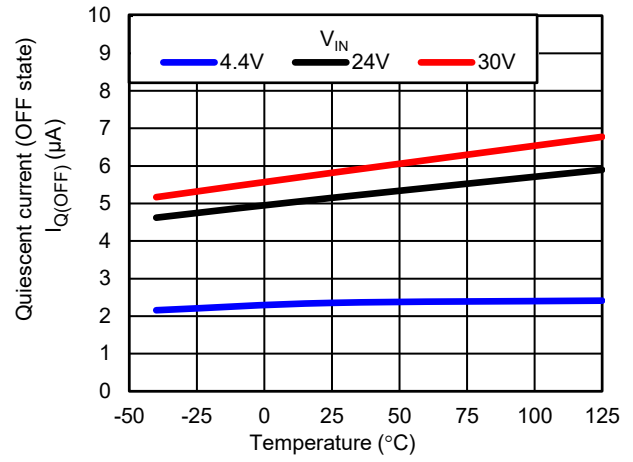

Figure 12.3 Quiescent current (ON state) I_Q
 $V_{IN} = 24\text{ V}$, $T_a = 25^\circ\text{C}$

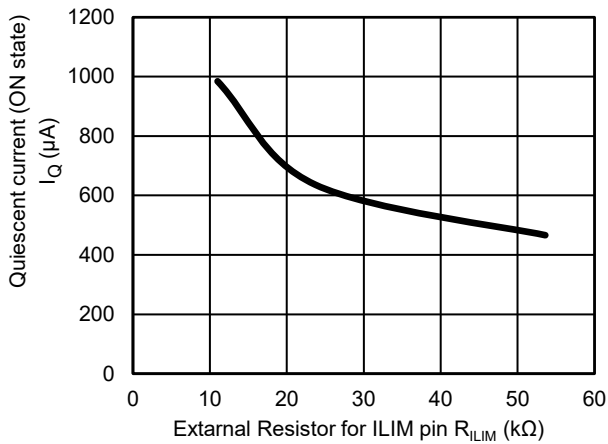

Figure 12.4 On resistance R_{ON}
 $I_{OUT} = 1.0\text{ A}$

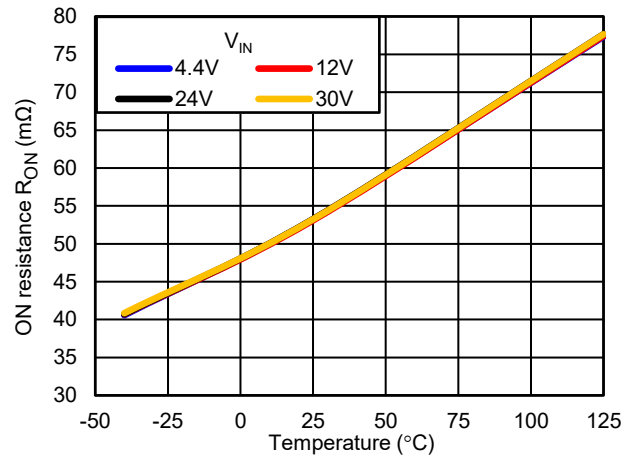

Figure 12.5 V_{IN} under voltage lockout (UVLO) threshold

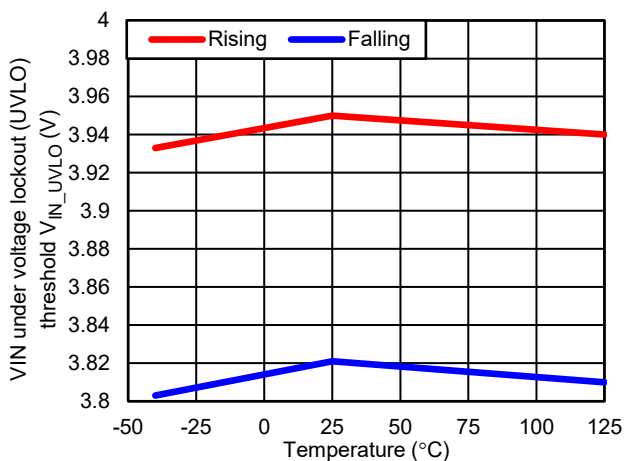

Figure 12.6 V_{IN} Overvoltage lockout (OVLO) Threshold voltage

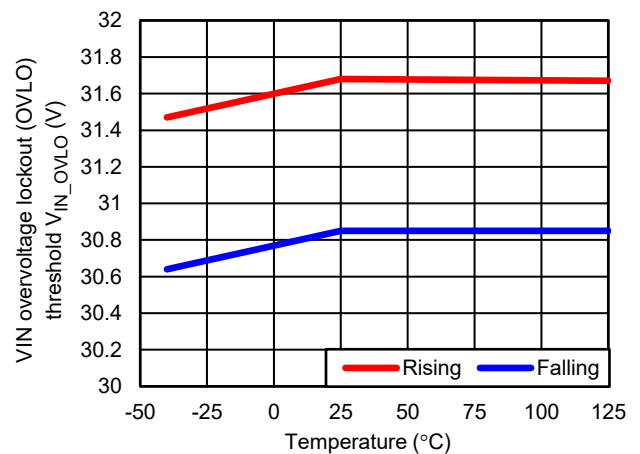

Figure 12.7 Output detection current I_{LIMP}
 $V_{IN} = 24\text{ V}$, $V_{EN} = 3\text{ V}$

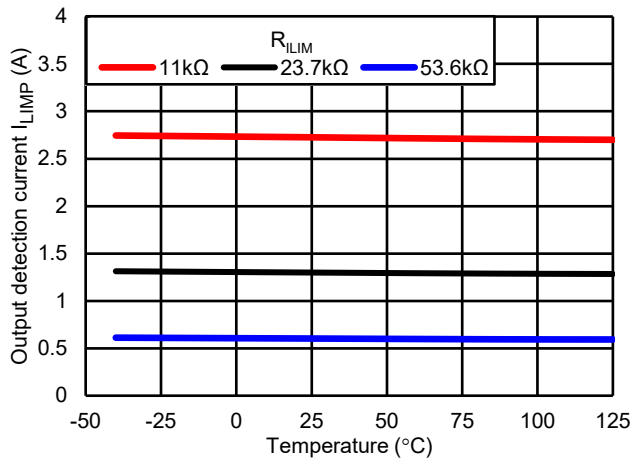

Figure 12.8 Output limit current I_{LIM}
 $V_{IN} = 24\text{ V}$, $V_{EN} = 3\text{ V}$

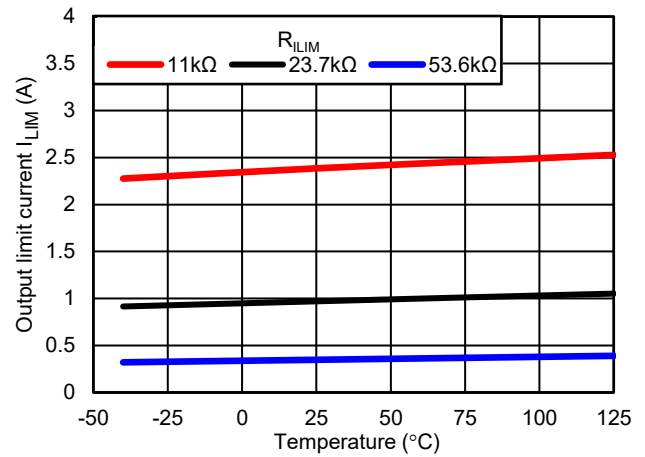

Figure 12.9 VOUT turn on
 $V_{IN} = 24\text{ V}$, $C_{OUT} = 1\text{ }\mu\text{F}$, $R_{OUT} = 200\text{ }\Omega$

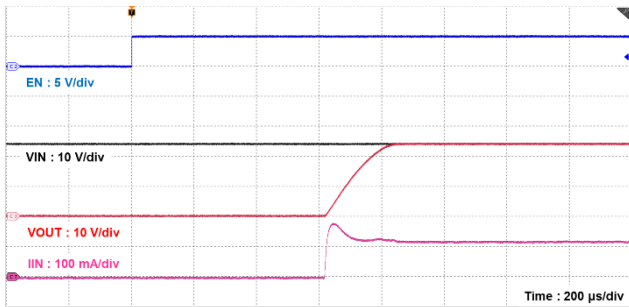

Figure 12.10 VOUT turn off
 $V_{IN} = 24\text{ V}$, $C_{OUT} = 1\text{ }\mu\text{F}$, $R_{OUT} = 200\text{ }\Omega$

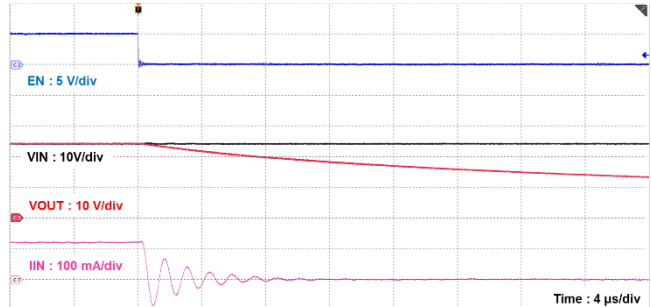

Figure 12.11 TCKE601RA Overcurrent limit Response (Auto-retry)
 $V_{IN} = 24\text{ V}$, $C_{OUT} = 1\text{ }\mu\text{F}$, $R_{LIM} = 11\text{ k}\Omega$, $R_{OUT} = \text{Open to } 8\text{ }\Omega$

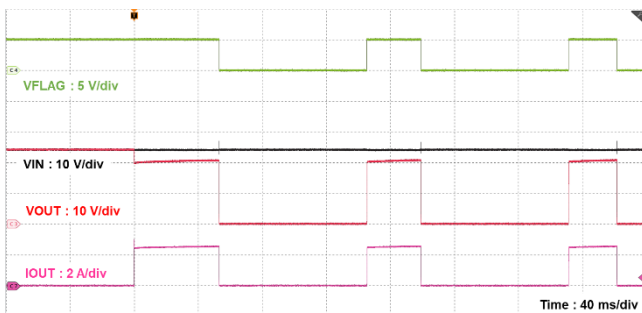

Figure 12.12 TCKE603RL Overcurrent limit Response (Latched)
 $V_{IN} = 24\text{ V}$, $C_{OUT} = 1\text{ }\mu\text{F}$, $R_{LIM} = 11\text{ k}\Omega$, $R_{OUT} = \text{Open to } 8\text{ }\Omega$

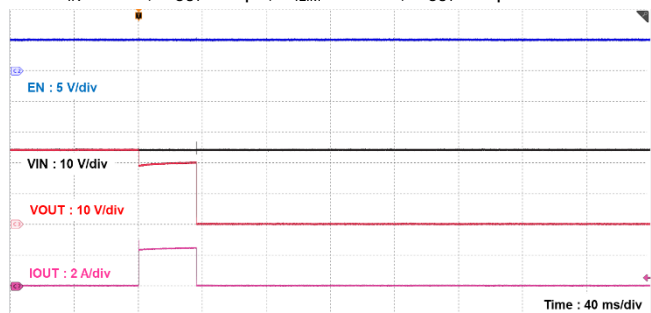

Figure 12.13 TCKE601RA Short-circuit protection (Auto-retry)
 $V_{IN} = 24\text{ V}$, $C_{OUT} = 1\text{ }\mu\text{F}$, $R_{LIM} = 11\text{ k}\Omega$, $R_{OUT} = \text{Open to short}$

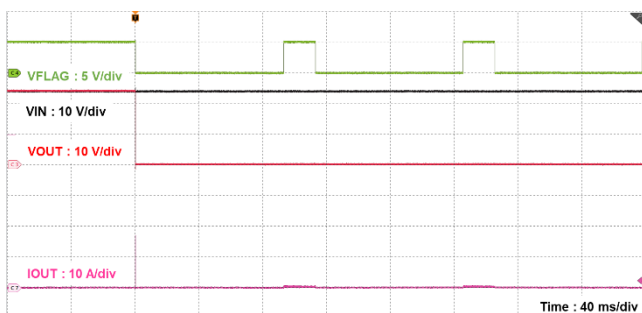

Figure 12.14 TCKE601RA Short-circuit protection (Zoom)
 $V_{IN} = 24\text{ V}$, $C_{OUT} = 1\text{ }\mu\text{F}$, $R_{LIM} = 11\text{ k}\Omega$, $R_{OUT} = \text{Open to short}$

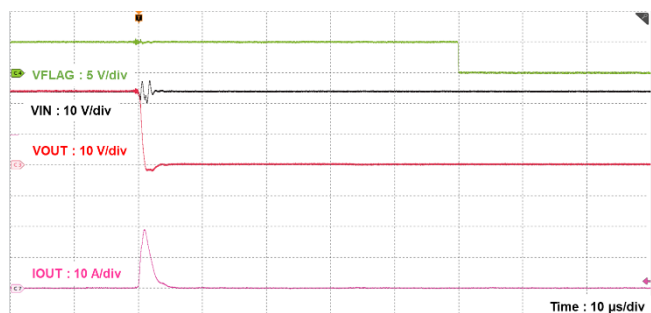

Figure 12.15 TCKE603RL Short-circuit protection (Latched)
 $V_{IN} = 24\text{ V}$, $C_{OUT} = 1\ \mu\text{F}$, $R_{ILIM} = 11\ \text{k}\Omega$, $R_{OUT} = \text{Open to short}$

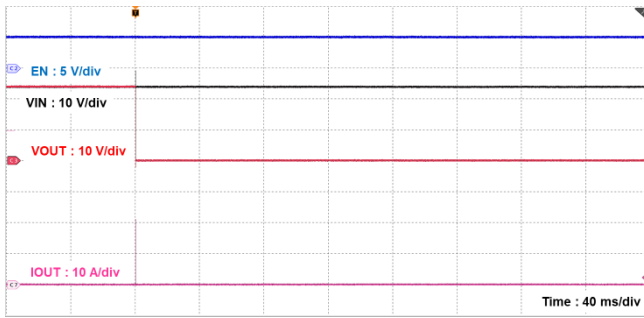

Figure 12.16 TCKE603RL Short-circuit protection (Zoom)
 $V_{IN} = 24\text{ V}$, $C_{OUT} = 1\ \mu\text{F}$, $R_{ILIM} = 11\ \text{k}\Omega$, $R_{OUT} = \text{Open to short}$

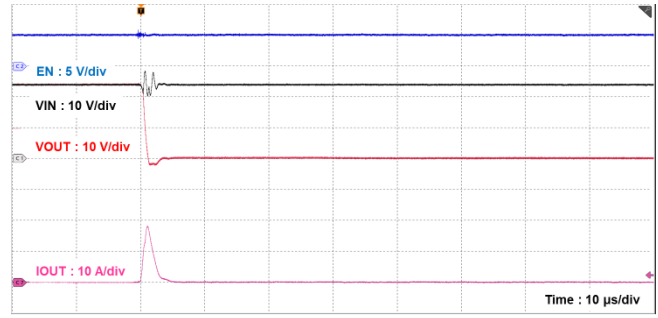
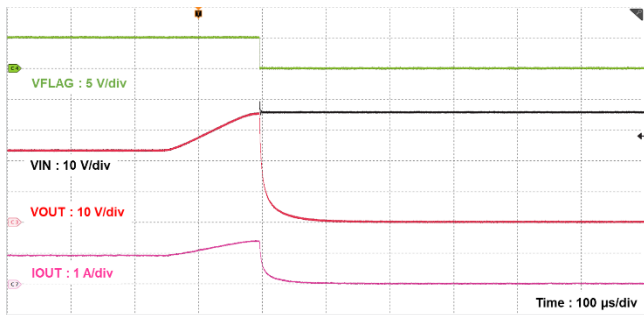

Figure 12.17 TCKE601RA Overvoltage protection (Auto-retry)
 $V_{IN} = 24\text{ V to }35\text{ V}$, $C_{OUT} = 1\ \mu\text{F}$, $R_{ILIM} = 11\ \text{k}\Omega$, $R_{OUT} = 25\ \Omega$



Note: The above characteristics curves are presented for reference only and not guaranteed by production test, unless otherwise noted.

13. Outline drawing

TSOP6F

unit: mm

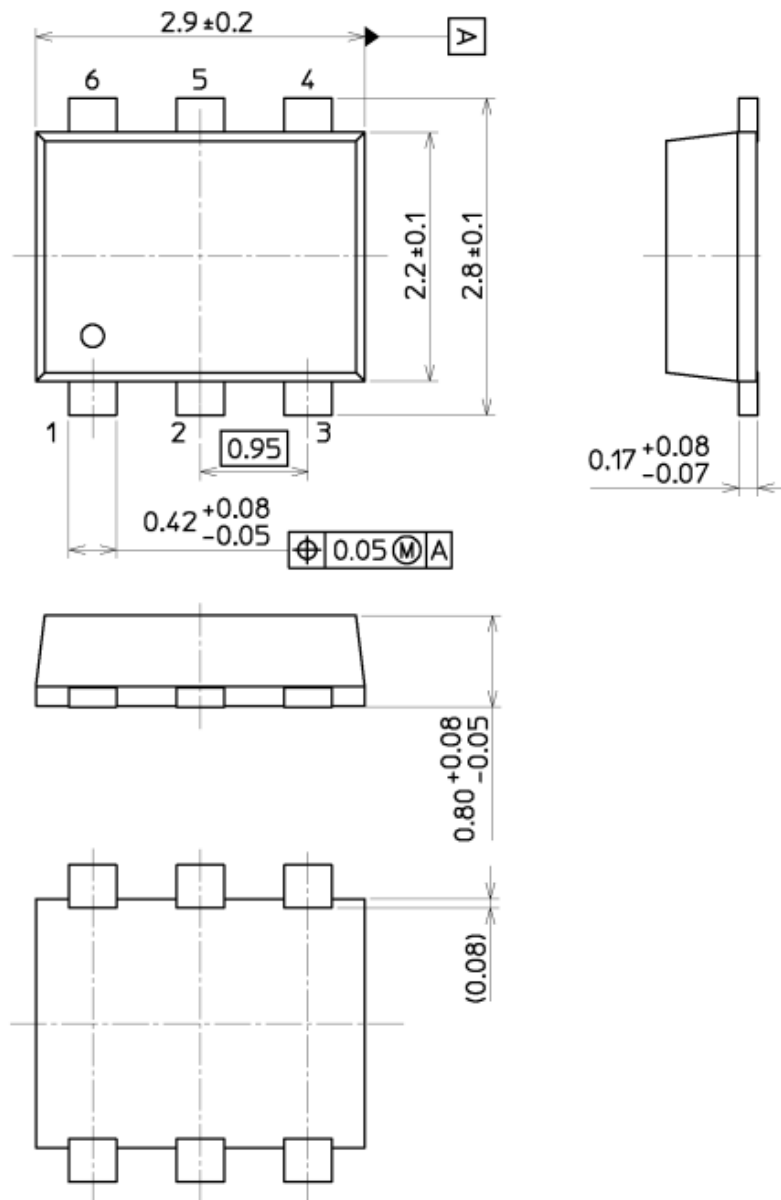

weight: 15 mg (typ.)

RESTRICTIONS ON PRODUCT USE

Toshiba Corporation and its subsidiaries and affiliates are collectively referred to as "TOSHIBA". Hardware, software and systems described in this document are collectively referred to as "Product".

- TOSHIBA reserves the right to make changes to the information in this document and related Product without notice.
- This document and any information herein may not be reproduced without prior written permission from TOSHIBA. Even with TOSHIBA's written permission, reproduction is permissible only if reproduction is without alteration/omission.
- Though TOSHIBA works continually to improve Product's quality and reliability, Product can malfunction or fail. Customers are responsible for complying with safety standards and for providing adequate designs and safeguards for their hardware, software and systems which minimize risk and avoid situations in which a malfunction or failure of Product could cause loss of human life, bodily injury or damage to property, including data loss or corruption. Before customers use the Product, create designs including the Product, or incorporate the Product into their own applications, customers must also refer to and comply with (a) the latest versions of all relevant TOSHIBA information, including without limitation, this document, the specifications, the data sheets and application notes for Product and the precautions and conditions set forth in the "TOSHIBA Semiconductor Reliability Handbook" and (b) the instructions for the application with which the Product will be used with or for. Customers are solely responsible for all aspects of their own product design or applications, including but not limited to (a) determining the appropriateness of the use of this Product in such design or applications; (b) evaluating and determining the applicability of any information contained in this document, or in charts, diagrams, programs, algorithms, sample application circuits, or any other referenced documents; and (c) validating all operating parameters for such designs and applications. **TOSHIBA ASSUMES NO LIABILITY FOR CUSTOMERS' PRODUCT DESIGN OR APPLICATIONS.**
- **PRODUCT IS NEITHER INTENDED NOR WARRANTED FOR USE IN EQUIPMENTS OR SYSTEMS THAT REQUIRE EXTRAORDINARILY HIGH LEVELS OF QUALITY AND/OR RELIABILITY, AND/OR A MALFUNCTION OR FAILURE OF WHICH MAY CAUSE LOSS OF HUMAN LIFE, BODILY INJURY, SERIOUS PROPERTY DAMAGE AND/OR SERIOUS PUBLIC IMPACT ("UNINTENDED USE").** Except for specific applications as expressly stated in this document, Unintended Use includes, without limitation, equipment used in nuclear facilities, equipment used in the aerospace industry, Class 3 medical devices, equipment used for automobiles, and military vehicles and munitions. **IF YOU USE PRODUCT FOR UNINTENDED USE, TOSHIBA ASSUMES NO LIABILITY FOR PRODUCT.** For details, please contact your TOSHIBA sales representative or contact us via our website.
- Do not disassemble, analyze, reverse-engineer, alter, modify, translate or copy Product, whether in whole or in part.
- Product shall not be used for or incorporated into any products or systems whose manufacture, use, or sale is prohibited under any applicable laws or regulations.
- The information contained herein is presented only as guidance for Product use. No responsibility is assumed by TOSHIBA for any infringement of patents or any other intellectual property rights of third parties that may result from the use of Product. No license to any intellectual property right is granted by this document, whether express or implied, by estoppel or otherwise.
- **ABSENT A WRITTEN SIGNED AGREEMENT, EXCEPT AS PROVIDED IN THE RELEVANT TERMS AND CONDITIONS OF SALE FOR PRODUCT, AND TO THE MAXIMUM EXTENT ALLOWABLE BY LAW, TOSHIBA (1) ASSUMES NO LIABILITY WHATSOEVER, INCLUDING WITHOUT LIMITATION, INDIRECT, CONSEQUENTIAL, SPECIAL, OR INCIDENTAL DAMAGES OR LOSS, INCLUDING WITHOUT LIMITATION, LOSS OF PROFITS, LOSS OF OPPORTUNITIES, BUSINESS INTERRUPTION AND LOSS OF DATA, AND (2) DISCLAIMS ANY AND ALL EXPRESS OR IMPLIED WARRANTIES AND CONDITIONS RELATED TO SALE, USE OF PRODUCT, OR INFORMATION, INCLUDING WARRANTIES OR CONDITIONS OF MERCHANTABILITY, FITNESS FOR A PARTICULAR PURPOSE, ACCURACY OF INFORMATION, OR NONINFRINGEMENT.**
- Do not use or otherwise make available Product or related software or technology for any military purposes, including without limitation, for the design, development, use, stockpiling or manufacturing of nuclear, chemical, or biological weapons or missile technology products (mass destruction weapons). Product and related software and technology may be controlled under the applicable export laws and regulations including, without limitation, the Japanese Foreign Exchange and Foreign Trade Law and the U.S. Export Administration Regulations. Export and re-export of Product or related software or technology are strictly prohibited except in compliance with all applicable export laws and regulations.
- Please contact your TOSHIBA sales representative for details as to environmental matters such as the RoHS compatibility of Product. Please use Product in compliance with all applicable laws and regulations that regulate the inclusion or use of controlled substances, including without limitation, the EU RoHS Directive. **TOSHIBA ASSUMES NO LIABILITY FOR DAMAGES OR LOSSES OCCURRING AS A RESULT OF NONCOMPLIANCE WITH APPLICABLE LAWS AND REGULATIONS.**

Toshiba Electronic Devices & Storage Corporation

<https://toshiba.semicon-storage.com/>