

# **Automotive Brushed DC Motor Control Circuit Using TB9103FTG Reference Guide**

## **RD245-RGUIDE-01**

---

**Toshiba Electronic Devices & Storage Corporation**

## Table of Contents

<b>1. Introduction</b>	<b>4</b>
<b>2. Specifications</b>	<b>5</b>
2.1. Block Diagram	6
2.2. PCB Appearance and Component Layout	7
<b>3. Schematic, Bill of Material, and PCB Pattern</b>	<b>11</b>
3.1. Schematic	11
3.2. Bill of Material	11
3.3. PCB Pattern	11
<b>4. Description of This Design</b>	<b>14</b>
4.1. Connectors	14
4.1.1. Input Power Supply Connector (CN1)	14
4.1.2. Motor Connector (CN3)	14
4.1.3. External MCU Control Connector (CN2)	15
4.1.4. External MCU Power Supply Connector (CN4)	16
4.2. Switches	18
4.2.1. Sleep Signal Switch (SW1)	18
4.2.2. Mode Selection Switch (SW6)	19
4.2.3. Motor Control Switches (SW2 to SW5)	20
4.2.4. VDS Threshold Setting Switch (SW7)	21
4.3. LEDs	22
<b>5. Operation</b>	<b>23</b>
5.1. H-Bridge Mode Operation	23
5.1.1. Starting Procedure	23

5.1.2. Stopping Procedure .....	24
5.2. Half-Bridge Mode Operation .....	25
5.2.1. Starting Procedure.....	25
5.2.2. Stopping Procedure .....	26
6. Precautions for Evaluation.....	27

## 1. Introduction

This Reference Guide (hereafter referred to as this guide) describes the reference design (hereafter referred to as this design) of Automotive Brushed DC Motor Control Circuit Using TB9103FTG.

Brushed DC motors are extensively used in actuators for doors, windows, seats, etc. of the modern automobiles. Toshiba's automotive 2-channel half-bridge gate driver IC [TB9103FTG](#) provides many features for better motor control. It can be used to control two motors in half-bridge mode or one motor in H-bridge mode. Its Dead time control, various fault detection functions, and fault detection output signals help in the safer implementation of motor operation. Its wide input voltage range makes it suitable for various applications. It also comes in a small QFN24 package (4 x 4mm) that enables compact implementation.

This design provides an easy way to test and evaluate various features and functions of TB9103FTG. It also allows the user to control the motor in two ways, first by manually adjusting the switches on the board and second by using an external microcontroller (MCU). This design also provides an option to test two types of power MOSFETs for driving the motor. These power MOSFETs are [XPN7R104NC](#) and [XPH3R304PS](#) which support the maximum current of 10A and 20A respectively. In addition, this design also features a reverse connection protector circuit which uses [XPH1R104PS](#) power MOSFET to protect the circuit if the polarity of input power supply is not correct. This design uses a [TB9005FNG](#) voltage regulator IC to generate 5V power supply. This 5V power supply is used in this design and can also be used to supply 5V power to an external MCU. TB9005FNG also features low-voltage reset, power-on reset, and watchdog timer function for better MCU operation.

## 2. Specifications

Table 2.1 lists the main specifications of this design.

**Table 2.1 Specifications of This Design**

Item	Specifications
Input Power Supply Voltage	DC 8V to 18V
Control Signal Voltage	DC 5V
Output Current	10A (Max.) with XPN7R104NC MOSFETs 20A (Max.) with XPH3R304PS MOSFETs
Driven Motor Type	Brushed DC Motor
Motor Control Modes	Half-Bridge Mode, and H-Bridge Mode
Board Size	75mm x 75mm
Board Layer Configuration	4-Layer Through-Hole (All Layers: 35µm each)

## 2.1. Block Diagram

Fig. 2.1 shows the block diagram of this design.

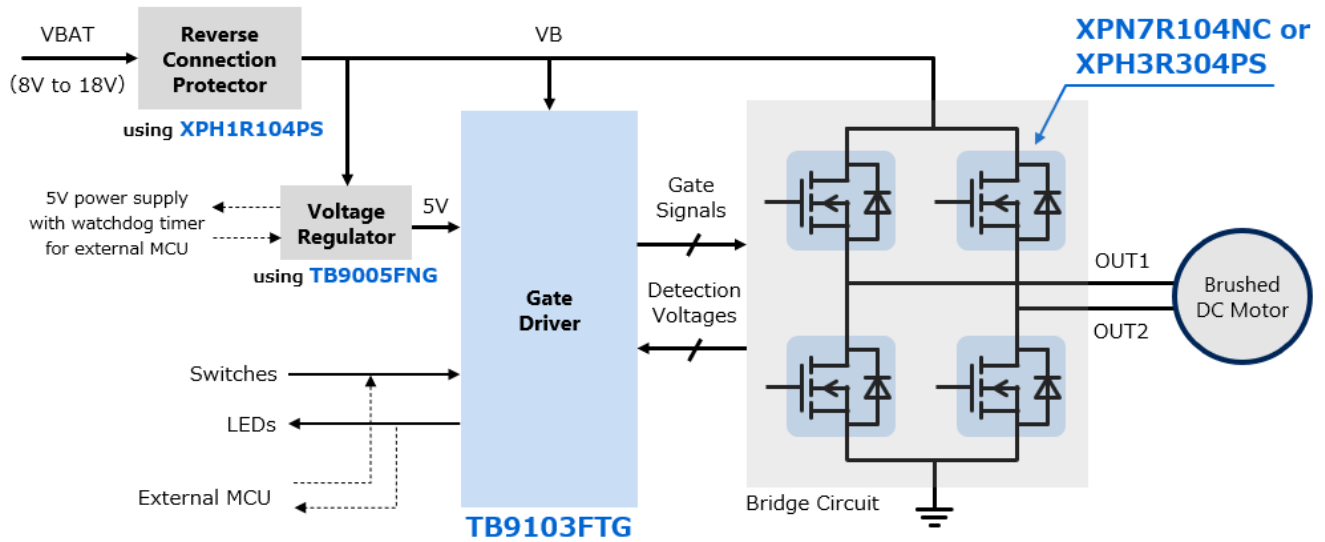

Fig. 2.1 Block Diagram of This Design

## 2.2. PCB Appearance and Component Layout

Fig. 2.2 to 2.6 show the appearance of this design, and Fig. 2.7 to 2.8 show the layout of the main components.

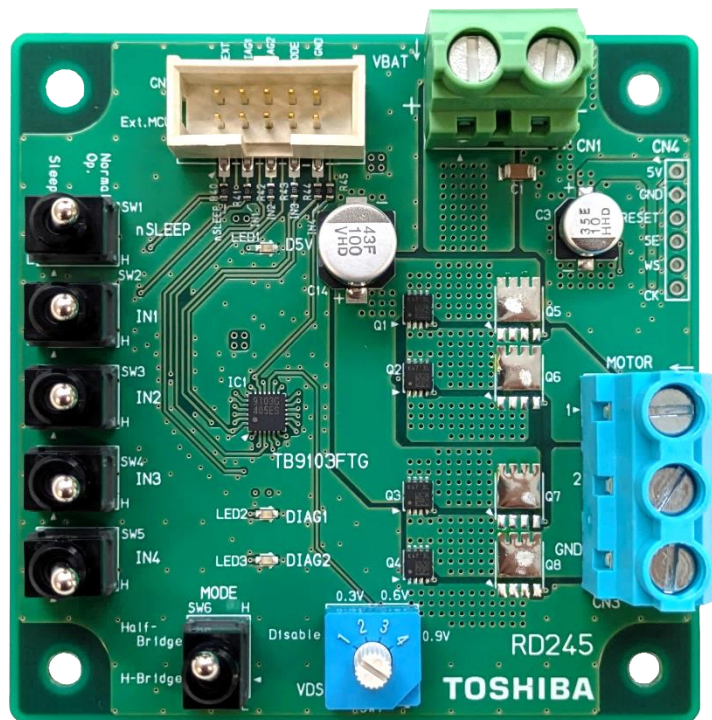

Fig. 2.2 Front View of This Design (with XPN7R104NC MOSFETs)

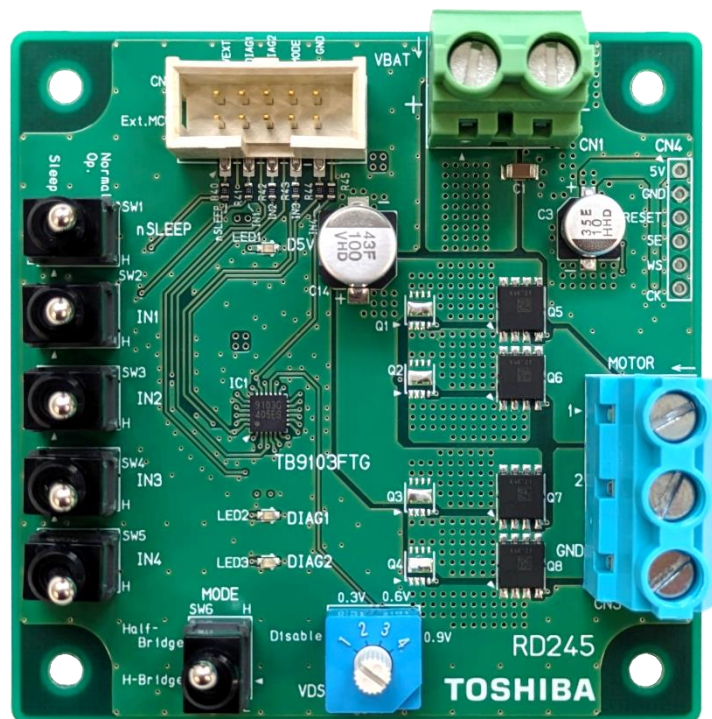

Fig. 2.3 Front View of This Design (with XPH3R304PS MOSFETs)

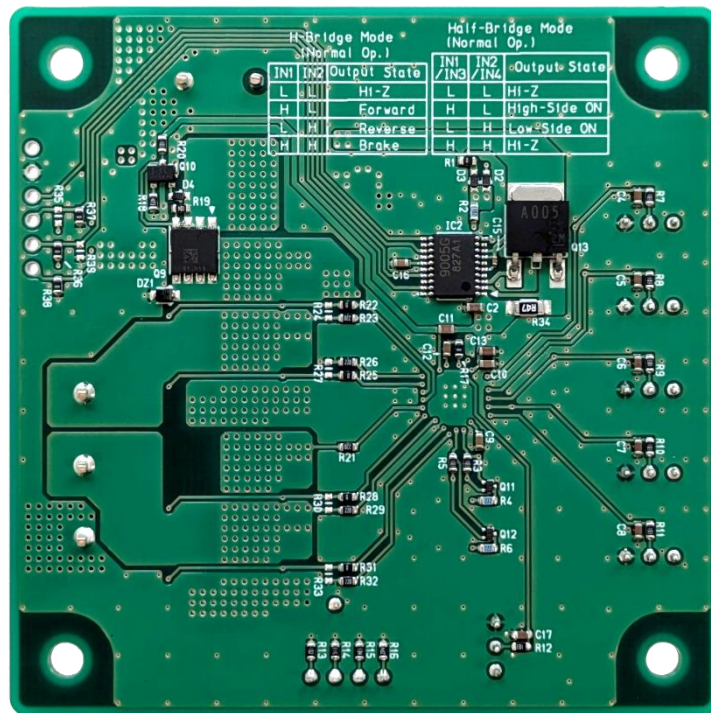

Fig. 2.4 Back View of This Design

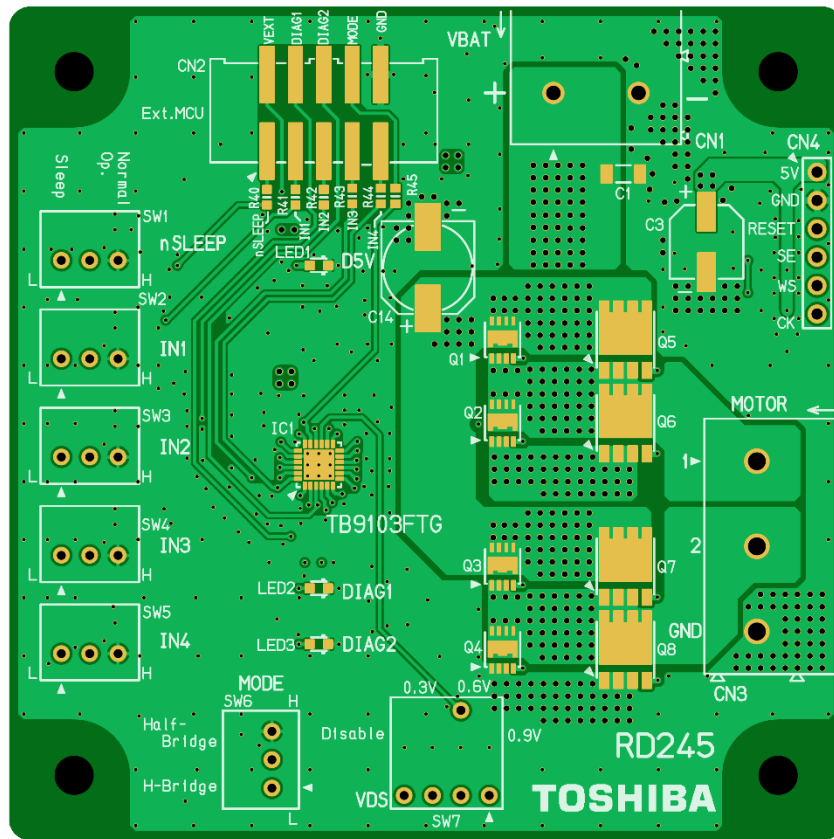



Fig. 2.5 Side View of This Design (with XPN7R104NC MOSFETs)



Fig. 2.6 Side View of This Design (with XPH3R304PS MOSFETs)



**Fig. 2.7 Main Component Layout (Front)**

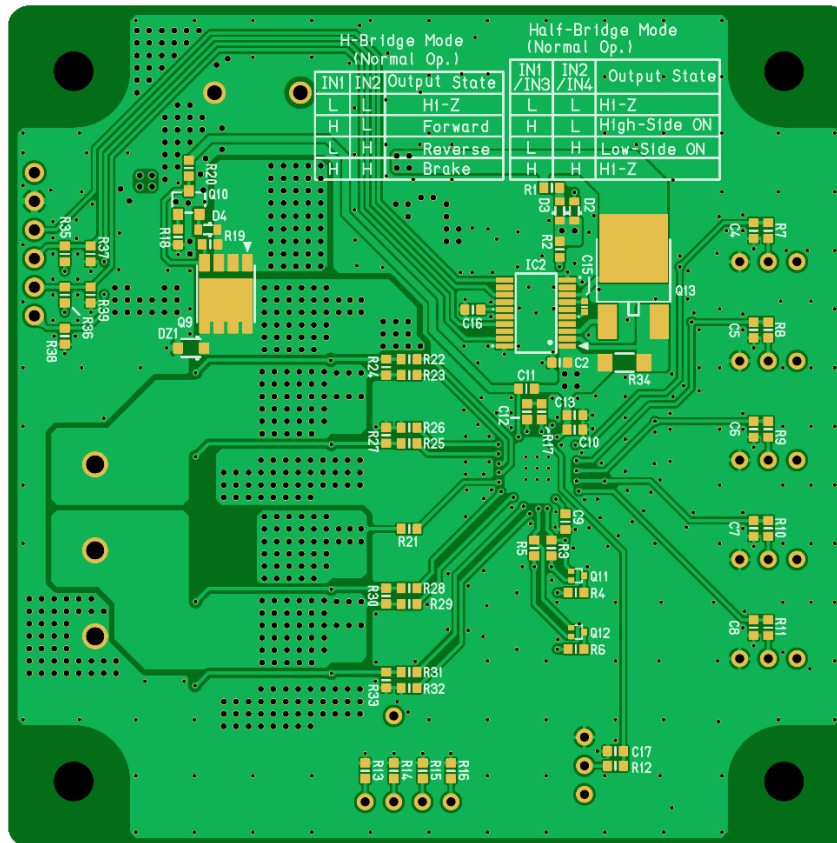

**Fig. 2.8 Main Component Layout (Back)**

## **3. Schematic, Bill of Material, and PCB Pattern**

### **3.1. Schematic**

Refer to the following file:

RD245-SCHEMATIC-xx.pdf

(xx is the revision number.)

### **3.2. Bill of Material**

Refer to the following file:

RD245-BOM-xx.pdf

(xx is the revision number.)

### **3.3. PCB Pattern**

Fig. 3.1 shows the PCB pattern of this design.

Also refer to the following file:

RD245-LAYER-xx.pdf

(xx is the revision number.)

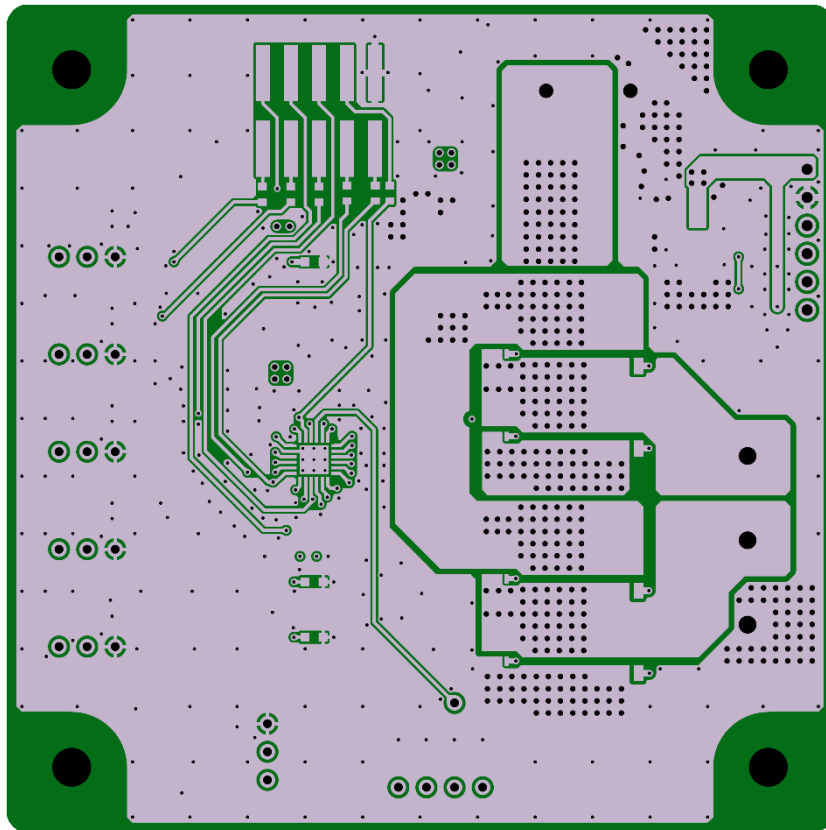

<Layer 1 Front Side>

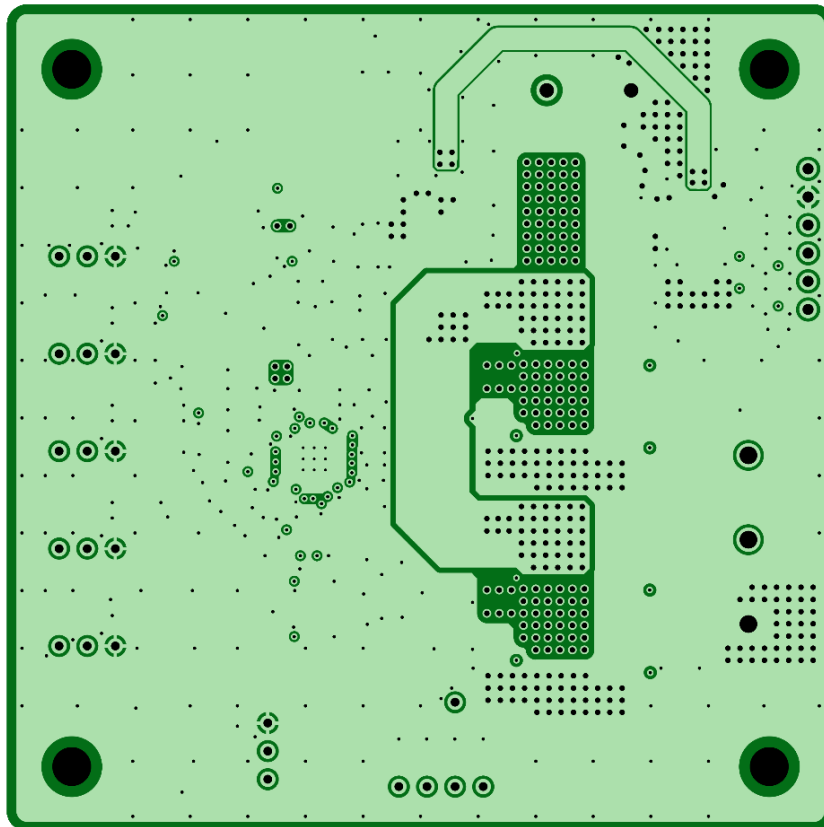

<Layer 2>

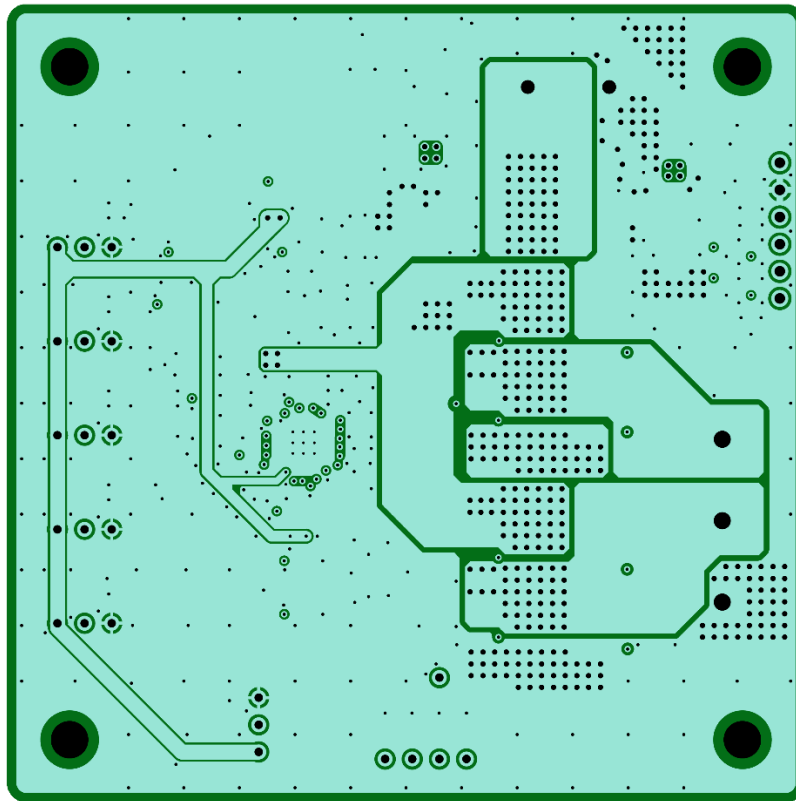

<Layer 3>

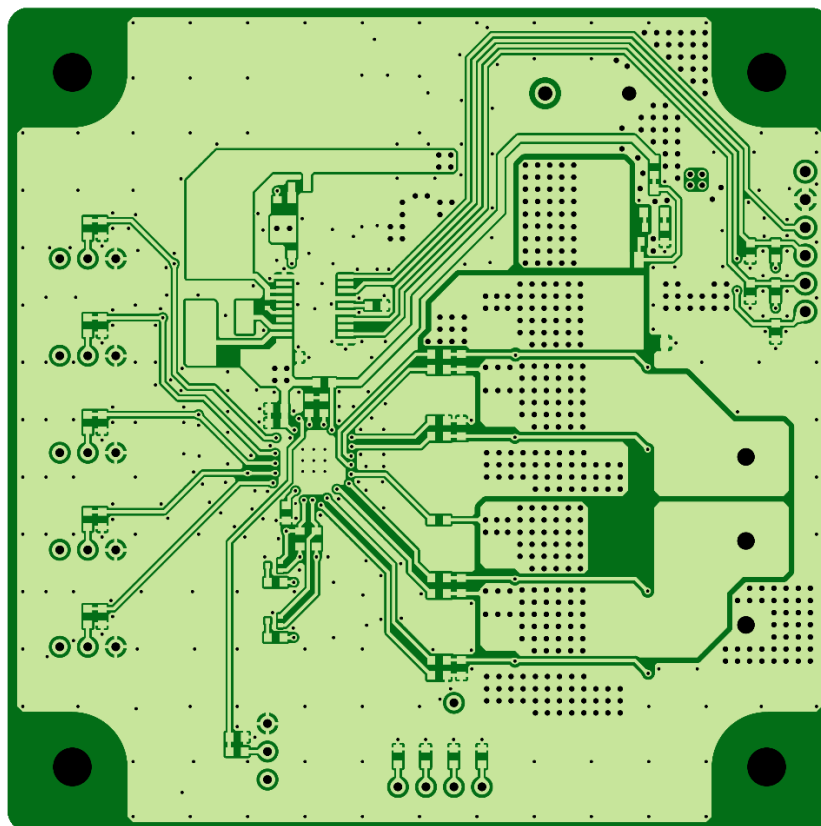

<Layer 4>

**Fig. 3.1 PCB Pattern (Top View)**

## 4. Description of This Design

Names and functions of various components of the PCB are described in this section.

### 4.1. Connectors

Connectors of this design are described in this section.

#### 4.1.1. Input Power Supply Connector (CN1)

This connector is used to supply input DC power supply (VBAT). A DC voltage between 8V and 18V can be input. 1868076 (Phoenix Contact) connector is used.

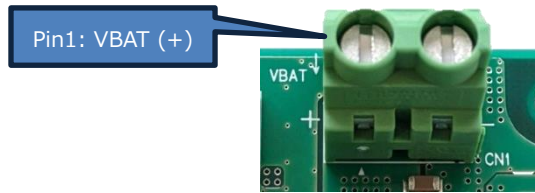

**Fig. 4.1 Input Power Supply Connector (CN1)**

**Table 4.1 Input Power Supply Connector (CN1) Specifications**

Pin	Net Name	Description
1	VBAT (+)	DC voltage (+) (8V to 18V)
2	GND (-)	DC voltage (-) (GND)

#### 4.1.2. Motor Connector (CN3)

This connector is used to connect one or two brushed DC motor(s) depending upon the selected mode via switch SW6. TB005-762-03BE (CUI Devices) connector is used.

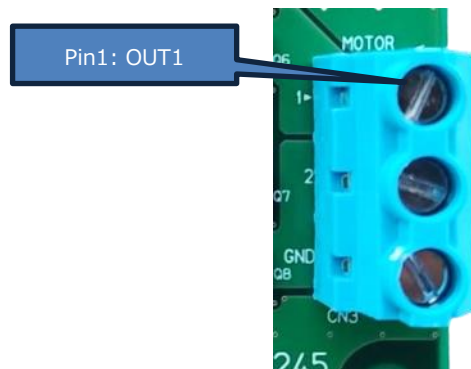

**Fig. 4.2 Motor Connector (CN3)**

**Table 4.2 Motor Connector (CN3) Specifications**

Pin	Net Name	Direction	Description
1	OUT1	Out	Motor connection
2	OUT2	Out	Motor connection
3	GND	-	GND

### 4.1.3. External MCU Control Connector (CN2)

This connector can be used to connect an external MCU for controlling the motor(s). HTST-105-01-L-DV (Samtec) connector is used.

The circuit design is such that the input signals of this connector have higher priority than the corresponding signals coming from SW1 to SW6. Therefore, if an external MCU is connected via this connector CN2, then the input signals are controlled via the MCU and cannot be controlled by switches SW1 to SW6. VEXT power supply pin allows the user to supply 5V from the external MCU board to TB9103FTG, instead of using the onboard 5V voltage regulator. This connector is for providing additional functionality and is not necessary for the operation of this design.

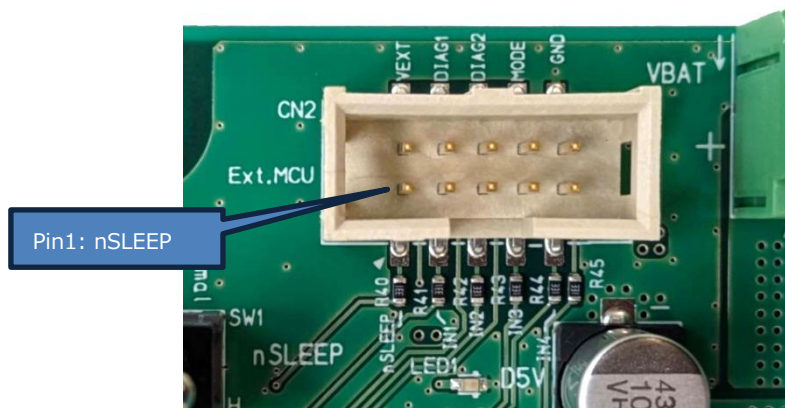

**Fig. 4.3 External MCU Control Connector (CN2)**

**Table 4.3 External MCU Control Connector (CN2) Specifications**

Pin	Net Name	Direction	Description
1	nSLEEP	In	Sleep signal
2	VEXT	In	5V power supply input for TB9103FTG (Optional)
3	IN1	In	Motor control signal
4	DIAG1	Out	Fault detection output signal
5	IN2	In	Motor control signal
6	DIAG2	Out	Fault detection output signal
7	IN3	In	Motor control signal
8	MODE	In	Operation mode control signal
9	IN4	In	Motor control signal
10	GND	-	GND

### 4.1.4. External MCU Power Supply Connector (CN4)

This connector can be used to supply 5V to an external MCU. M20-9990645 (Harwin) connector is used.

The 5V provided from this connector (CN4) is generated by the TB9005FNG voltage regulator of this design. In addition, TB9005FNG features low-voltage reset, power-on reset, and watchdog timer reset functions, and provides a RESET signal output for the external MCU. For more details refer to the datasheet of TB9005FNG. This connector is for providing additional functionality and is not necessary for the operation of this design.

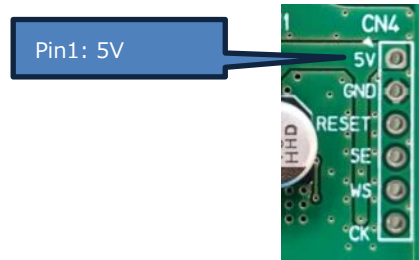
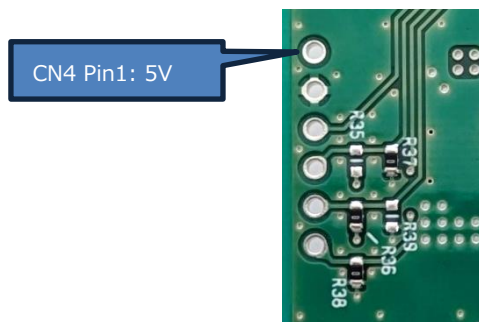

**Fig. 4.4 External MCU Power Supply Connector (CN4)**

**Table 4.4 External MCU Power Supply Connector (CN4) Specifications**

Pin	Net Name	Direction	Description
1	5V	Out	5V power supply for external MCU (Max. output current is 0.5A)
2	GND	-	GND
3	RESET	Out	RESET signal for external MCU
4	SE	In	Signal for setting threshold for low-voltage reset
5	WS	In	Signal for turning on/off the watchdog timer
6	CK	In	Clock signal input for watchdog timer operation (R38 must be removed before connecting a clock signal)

CN4 is not mounted because it provides optional features for external MCU. Therefore, in this design resistors R35 to R39 are used to configure SE, WS and CK signals of TB9005FNG. However, these resistors must be configured according to the desired use case. Please refer to the circuit diagram of this design before connecting any external signal to CN4.



**Fig. 4.5 Resistors for Setting SE, WS and CK Signals**



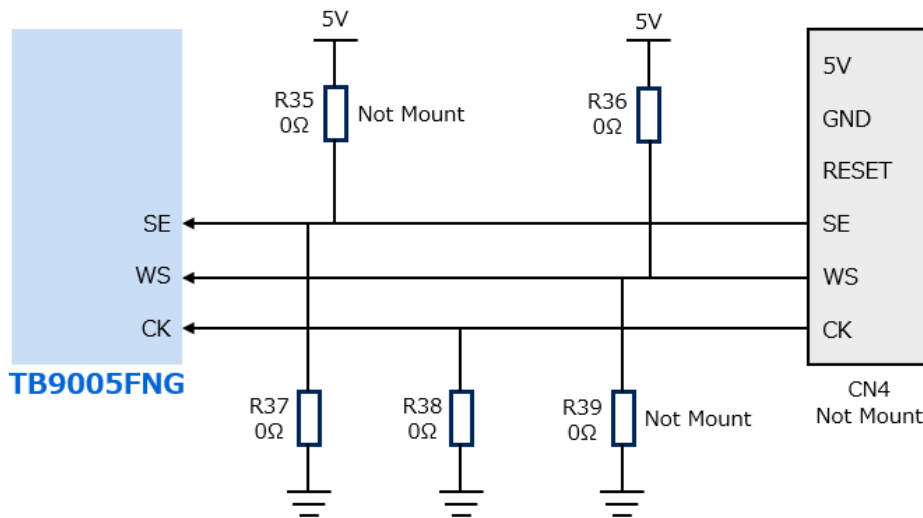

**Fig. 4.6 Block Diagram of Resistors for Setting SE, WS and CK Signals**

SE signal is used to set the threshold level for low-voltage reset function of TB9005FNG. By default, this signal is connected to ground on this board via 0Ω resistor R37. The user can use R35 or R37 to configure SE signal on this board. This signal can also be controlled from outside via pin 4 of CN4, however in this case resistors R35 and R37 must be removed.

**Table 4.5 SE Signal Specifications**

SE	Low-voltage reset function threshold level
Low	4.25V (Typ.) (Default setting using R37)
High	4.75V (Typ.)

WS signal is used to turn on or turn off the watchdog timer of TB9005FNG. By default, watchdog timer is not used, therefore this signal is connected to 5V on this board via 0Ω resistor R36. The user can use R36 or R39 to configure WS signal on this board. This signal can also be controlled from outside via pin 5 of CN4, however in this case resistors R35 and R37 must be removed. In addition, R38 must be removed before connecting a clock signal on CK (pin 6) of CN4.

**Table 4.6 WS Signal Specifications**

WS	Watchdog Timer
Low	On
High	Off (Default setting using R36)

## 4.2. Switches

Switches of this design are described in this section.

### 4.2.1. Sleep Signal Switch (SW1)

This switch is used to control sleep signal (nSLEEP) of TB9103FTG. B12AP (NKK) switch is used. Table 4.7 shows the function of the nSLEEP signal.

If an external MCU is connected via CN2, then this switch won't be able to control the signal.

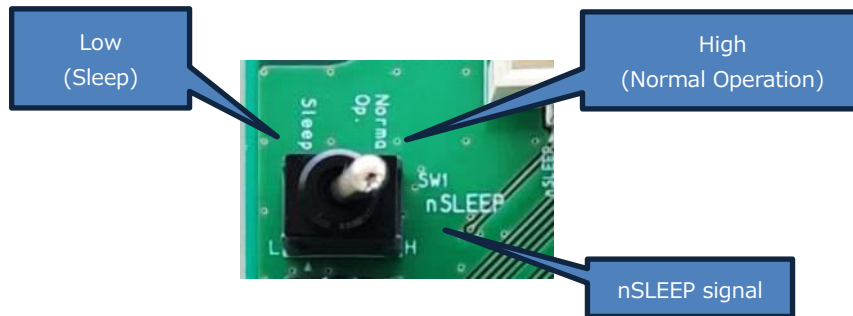

Fig. 4.7 Sleep Signal Switch (SW1)

Table 4.7 Sleep Signal Setting Using SW1

nSLEEP (SW1)	TB9103FTG State
Low	Sleep
High	Normal Operation

## 4.2.2. Mode Selection Switch (SW6)

This switch is used to set the operation mode selection signal (MODE) of TB9103FTG. B12AP (NKK) switch is used. Table 4.8 shows the function of the MODE signal.

If an external MCU is connected via CN2, then this switch won't be able to control the signal.

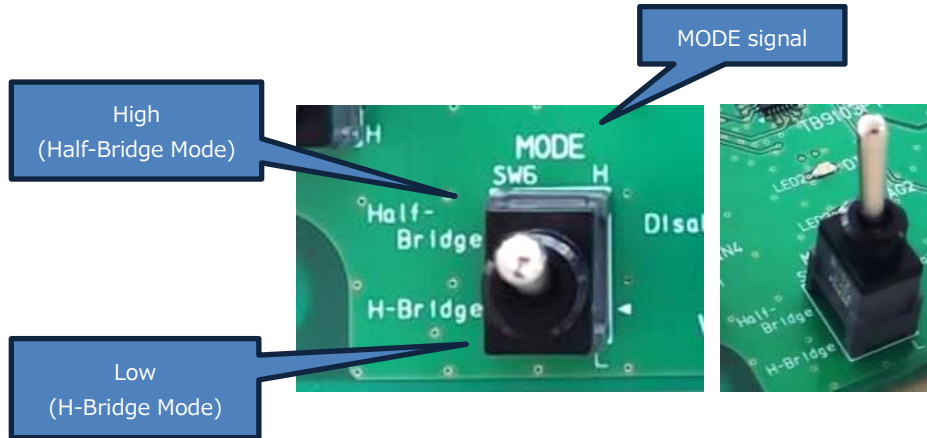

**Fig. 4.8 Mode Selection Switch (SW6)**

**Table 4.8 MODE Selection Setting Using SW6**

MODE (SW6)	Operation Mode
Low	H-Bridge Mode
High	Half-Bridge Mode

### 4.2.3. Motor Control Switches (SW2 to SW5)

These switches are used to control the connected motor(s) using signals IN1, IN2, IN3, and IN4. B12AP (NKK) switches are used.

If an external MCU is connected via CN2, then these switches won't be able to control their corresponding signals.

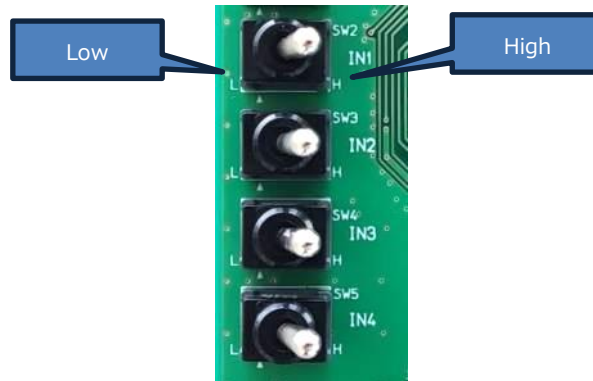

**Fig. 4.9 Motor Control Switches (SW2 to SW5)**

The use of these signals change based on the operation mode selected using MODE signal (SW6). The use of these signals in H-bridge mode is shown in Table 4.9. Signals IN3 and IN4 are not used in H-bridge mode.

**Table 4.9 Motor Control Setting in H-Bridge Mode Using SW2 and SW3**

IN1 (SW2)	IN2 (SW3)	Output State
Low	Low	Hi-Z
High	Low	Forward Drive (OUT1-OUT2: positive voltage)
Low	High	Reverse Drive (OUT1-OUT2: negative voltage)
High	High	Brake

In half-bridge mode two motor can be driven by channels CH1 and CH2 of TB9103FTG. The use of these signals in half-bridge mode is shown in Table 4.10 and 4.11.

**Table 4.10 Motor Control Setting in Half-Bridge Mode (CH1) Using SW2 and SW3**

IN1 (SW2)	IN2 (SW3)	Output State
Low	Low	Hi-Z
High	Low	High-Side ON (OUT1: VBAT)
Low	High	Low-Side ON (OUT1: GND)
High	High	Hi-Z

**Table 4.11 Motor Control Setting in Half-Bridge Mode (CH2) Using SW4 and SW5**

IN3 (SW4)	IN4 (SW5)	Output State
Low	Low	Hi-Z
High	Low	High-Side ON (OUT2: VBAT)
Low	High	Low-Side ON (OUT2: GND)
High	High	Hi-Z

**4.2.4. VDS Threshold Setting Switch (SW7)**

This switch is used to set VDS threshold voltage for detection. S-2150 (Nidec Copal) switch is used. Description of the VDS threshold setting is shown in Table 4.12. For more details refer to the datasheet of TB9103FTG.



**Fig. 4.10 VDS Threshold Setting Switch (SW7)**

**Table 4.12 VDS Threshold Setting Using SW7**

SW7 Switch Position	Detection Level
1	Disable
2	0.3V
3	0.6V
4	0.9V

### 4.3. LEDs

D5V LED (Yellow Green) turns on when D5V voltage is available. This LED is shown in Fig. 4.11. D5V is the 5V power supply used in this design.



**Fig. 4.11 D5V LED (LED1, Yellow Green)**

One or both DIAG1 LED (Red) and DIAG2 LED (Yellow) turn on when a fault is detected by TB9103FTG. These LEDs are shown in Fig. 4.12. These LEDs turn on when corresponding DIAG signal is Low. Overview of fault detection is shown in Table 4.13. For more details regarding fault detection refer to the datasheet of TB9103FTG.



**Fig. 4.12 DIAG1 LED (LED2, Red) and DIAG2 LED (LED3, Yellow)**

**Table 4.13 Fault Detection Overview**

LED2 (DIAG1)	LED3 (DIAG2)	DIAG1 Level Status	DIAG2 Level Status	Detected Fault
On	Off	Low	High	Fault on CH1
Off	On	High	Low	Fault on CH2
On	On	Low	Low	Fault common to both channels
Off	Off	High	High	-

## 5. Operation

### 5.1. H-Bridge Mode Operation

In H-bridge mode, a single brushed DC motor can be driven in both directions.

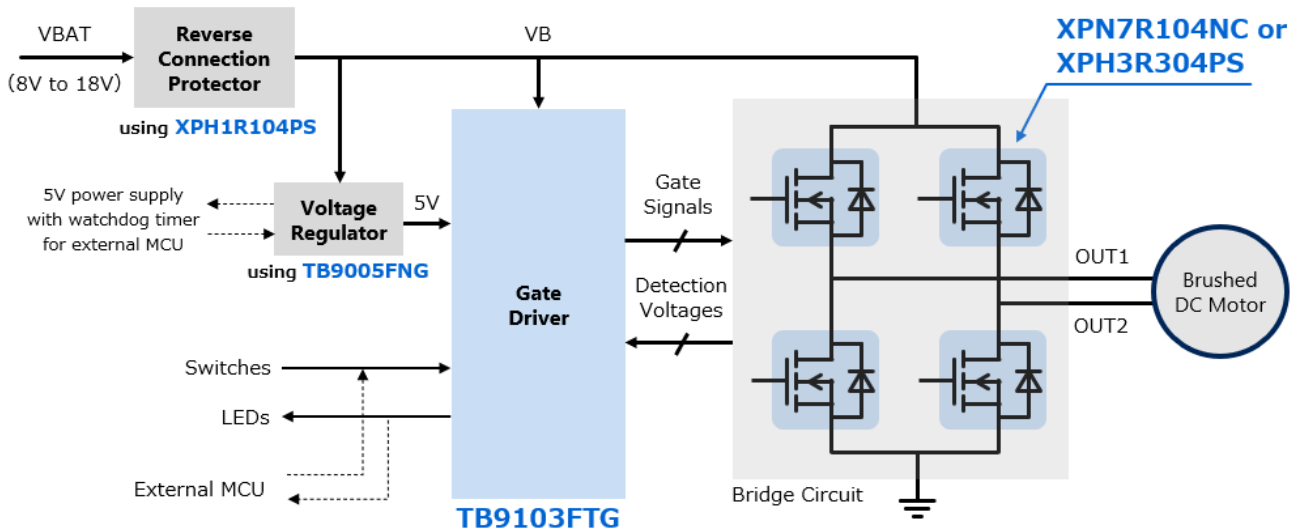

**Fig. 5.1 Motor Connection for H-Bridge Mode Operation**

#### 5.1.1. Starting Procedure

This section describes the procedure for starting this design in H-bridge mode.

Connection:

- Connect a brushed DC motor to OUT1 and OUT2 of CN3
- Connect input power supply VBAT wires to CN1

Board Configuration:

- Set nSLEEP to Low (Sleep) via SW1
- Set MODE to Low (H-Bridge Mode) via SW6
- Set IN1 to Low via SW2
- Set IN2 to Low via SW3
- Set VDS according to the requirement via SW7

Startup:

- Turn on the input power supply VBAT (8V to 18V) connected to CN1
- Switch nSLEEP to High (Normal Operation) via SW1
- Switch IN1 (or IN2) to High via SW2 (or SW3) to start the motor  
(Refer to Table 4.9 for more details)

Note: If an external MCU is connected via CN2, then switches SW1 to SW6 cannot control their corresponding signals. Therefore, corresponding signal must be controlled via external MCU according to the procedure described above.

### 5.1.2. Stopping Procedure

This section describes the procedure for stopping this design.

- Stop the motor by setting the output to Hi-Z state (by setting both SW2 and SW3 to Low) or Brake state (by setting both SW2 and SW3 to High) according to Table 4.9
- Set nSLEEP to Low (Sleep) via SW1
- Turn off the input power supply VBAT connected to CN1



### 5.2. Half-Bridge Mode Operation

In half-bridge mode, a brushed DC motor can be driven in one direction. TB9103FTG can drive two brushed DC motors via its two channels. Fig. 5.2 shows the motor connection for driving a single motor in half-bridge mode using channel CH1. For reference other motor connection configurations are shown in Fig. 5.3.

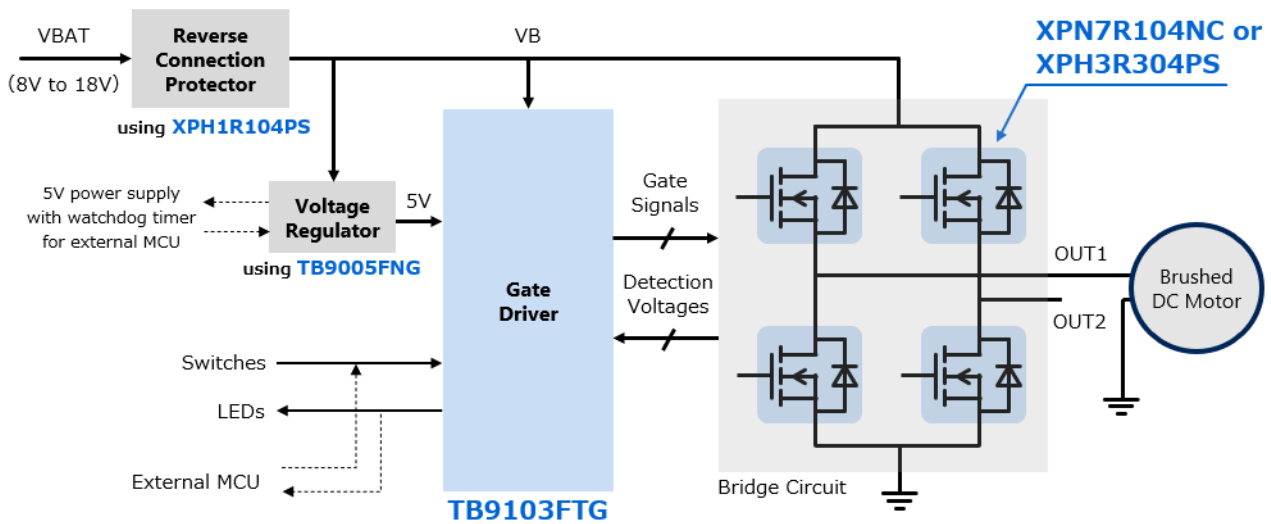

**Fig. 5.2 Motor Connection for Half-Bridge Motor Operation (using CH1)**

#### 5.2.1. Starting Procedure

This section describes the procedure for starting this design in half-bridge mode using CH1 as shown in Fig. 5.2.

Connection:

- Connect a brushed DC motor to OUT1 and GND of CN3
- Connect input power supply VBAT wires to CN1

Board Configuration:

- Set nSLEEP to Low (Sleep) via SW1
- Set MODE to High (Half-Bridge Mode) via SW6
- Set IN1 to Low via SW2
- Set IN2 to Low via SW3
- Set VDS according to the requirement via SW7

Startup:

- Turn on the input power supply VBAT (8V to 18V) connected to CN1
- Switch nSLEEP to High (Normal Operation) via SW1
- Switch IN1 to High via SW2 to start the motor  
(Refer to Table 4.10 for more details)

Note: If an external MCU is connected via CN2, then switches SW1 to SW6 cannot control their corresponding signals. Therefore, corresponding signal must be controlled via external MCU according to the procedure described above.

### 5.2.2. Stopping Procedure

This section describes the procedure for stopping this design.

- Stop the motor by setting the output to Hi-Z state (by setting both SW2 and SW3 to Low or by setting both SW2 and SW3 to High) or Brake state (by setting SW2 to Low and SW3 to High) according to Table 4.10
- Set nSLEEP to Low (sleep) via SW1
- Turn off the input power supply VBAT connected to CN1

Note: In Half-bridge mode, the motor can be connected in multiple configurations as shown in Figure 5.3. The method for starting and stopping the motor is different in each configuration. Refer to Table 4.10 and Table 4.11 for more details about controlling the motor in half-bridge mode.

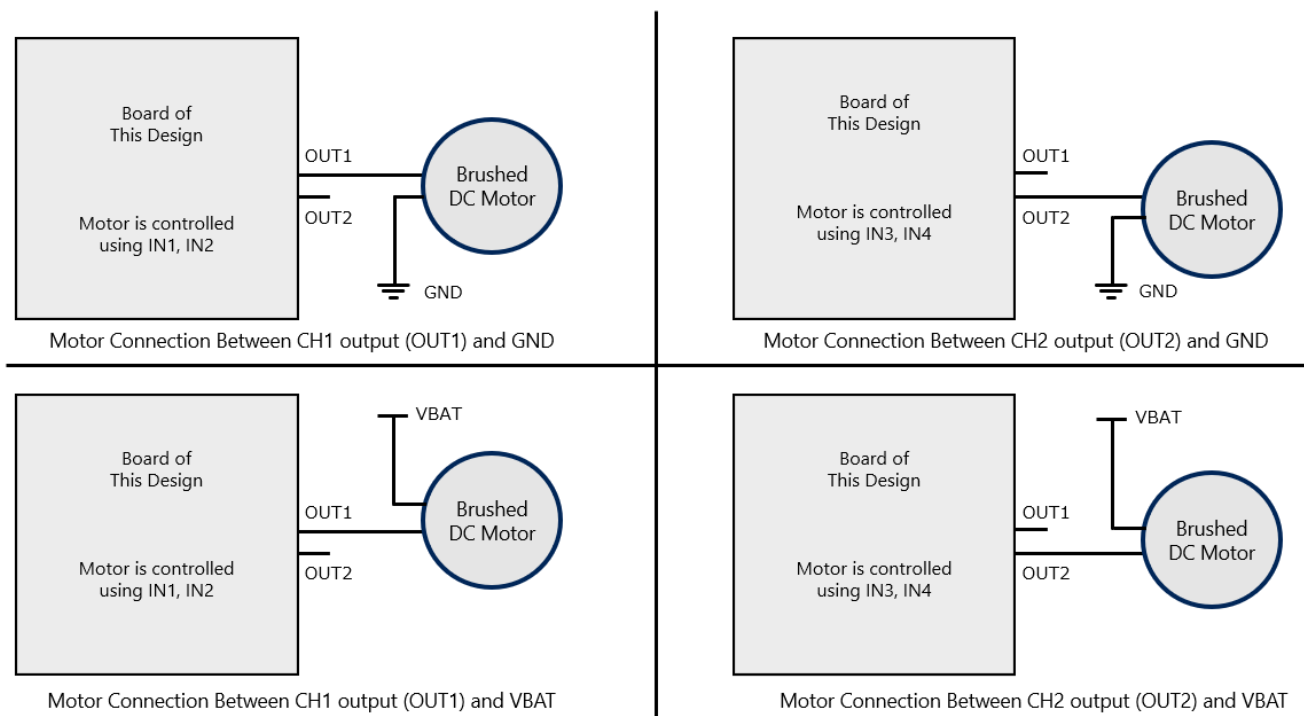

**Fig. 5.3 Various Motor Connection Configurations for Driving a Motor in Half-Bridge Mode**

## 6. Precautions for Evaluation

Pay special attention to the following when using this design:

- Make sure that the polarities of all connections are correct before supplying electricity.
- Make sure that the capacitors are sufficiently discharged before touching the BOARD.
- When checking the operation, cover the BOARD and motor with an acrylic case for safety.
- MOSFET and other components may generate heat during operation. Be careful not to get burned while handling them.

## Terms of Use

This terms of use is made between Toshiba Electronic Devices and Storage Corporation ("We") and Customer who downloads or uses this Reference Design. Customer shall comply with this terms of use. This Reference Design means all documents and data in order to design electronics applications on which our semiconductor device is embedded.

### **Section 1. Restrictions on usage**

1. This Reference Design is provided solely as reference data for designing electronics applications. Customer shall not use this Reference Design for any other purpose, including without limitation, verification of reliability.
2. Customer shall not use this Reference Design for sale, lease or other transfer.
3. Customer shall not use this Reference Design for evaluation in high or low temperature, high humidity, or high electromagnetic environments.
4. This Reference Design shall not be used for or incorporated into any product or system whose manufacture, use, or sale is prohibited under any applicable laws or regulations.

### **Section 2. Limitations**

1. We reserve the right to make changes to this Reference Design without notice.
2. This Reference Design should be treated as a reference only. WE ARE NOT RESPONSIBLE FOR ANY INCORRECT OR INCOMPLETE DATA AND INFORMATION.
3. Semiconductor devices can malfunction or fail. When designing electronics applications by referring to this Reference Design, Customer is responsible for complying with safety standards and for providing adequate designs and safeguards for their hardware, software and systems which minimize risk and avoid situations in which a malfunction or failure of semiconductor devices could cause loss of human life, bodily injury or damage to property, including data loss or corruption. Customer must also refer to and comply with the latest versions of all relevant our information, including without limitation, specifications, data sheets and application notes for semiconductor devices, as well as the precautions and conditions set forth in the "Semiconductor Reliability Handbook".
4. Designing electronics applications by referring to this Reference Design, Customer must evaluate the whole system sufficiently. Customer is solely responsible for applying this Reference Design to Customer's own product design or applications. WE ASSUME NO LIABILITY FOR CUSTOMER'S PRODUCT DESIGN OR APPLICATIONS.
5. WE SHALL NOT BE RESPONSIBLE FOR ANY INFRINGEMENT OF PATENTS OR ANY OTHER INTELLECTUAL PROPERTY RIGHTS OF THIRD PARTIES THAT MAY RESULT FROM THE USE OF THIS REFERENCE DESIGN. NO LICENSE TO ANY INTELLECTUAL PROPERTY RIGHT IS GRANTED BY THIS TERMS OF USE, WHETHER EXPRESS OR IMPLIED, BY ESTOPPEL OR OTHERWISE.
6. THIS REFERENCE DESIGN IS PROVIDED "AS IS". WE (a) ASSUME NO LIABILITY WHATSOEVER, INCLUDING WITHOUT LIMITATION, INDIRECT, CONSEQUENTIAL, SPECIAL, OR INCIDENTAL DAMAGES OR LOSS, INCLUDING WITHOUT LIMITATION, LOSS OF PROFITS, LOSS OF OPPORTUNITIES, BUSINESS INTERRUPTION AND LOSS OF DATA, AND (b) DISCLAIM ANY AND ALL EXPRESS OR IMPLIED WARRANTIES AND CONDITIONS RELATED TO THIS REFERENCE DESIGN, INCLUDING WITHOUT LIMITATION, WARRANTIES OR CONDITIONS OF FUNCTION AND WORKING, WARRANTIES OF MERCHANTABILITY, FITNESS FOR A PARTICULAR PURPOSE, ACCURACY OF INFORMATION, OR NONINFRINGEMENT.

### **Section 3. Terms and Termination**

It is assumed that Customer agrees to any and all this terms of use if Customer downloads or uses this Reference Design. We may, at its sole and exclusive discretion, change, alter, modify, add, and/or remove any part of this terms of use at any time without any prior notice. We may terminate this terms of use at any time and without any cause. Upon termination of this terms of use, Customer shall eliminate this Reference Design. Furthermore, upon our request, Customer shall submit to us a written confirmation to prove elimination of this Reference Design.

### **Section 4. Export Control**

Customer shall not use or otherwise make available this Reference Design for any military purposes, including without limitation, for the design, development, use, stockpiling or manufacturing of nuclear, chemical, or biological weapons or missile technology products (mass destruction weapons). This Reference Design may be controlled under the applicable export laws and regulations including, without limitation, the Japanese Foreign Exchange and Foreign Trade Act and the U.S. Export Administration Regulations. Export and re-export of this Reference Design is strictly prohibited except in compliance with all applicable export laws and regulations.

### **Section 5. Governing Laws**

This terms of use shall be governed and construed by laws of Japan, without reference to conflict of law principle.

### **Section 6. Jurisdiction**

Unless otherwise specified, Tokyo District Court in Tokyo, Japan shall be exclusively the court of first jurisdiction for all disputes under this terms of use.