

**DC 300 V Input BLDC Motor
Sensorless Control Circuit
Using TPD4165K**

Reference Guide

RD179d-RGUIDE-01

Toshiba Electronic Devices & Storage Corporation

Table of Contents

1. Introduction	3
2. Specifications	4
2.1. Circuit Block Diagrams	4
2.2. External View and Component Layout	5
3. Circuit Diagram, Bills of Material, and PCB Pattern Diagram	7
3.1. Circuit Diagram	7
3.2. Component List	7
3.3. PCB Pattern Diagram	7
4. Description of Circuit Operation	9
4.1. Name and Function of Components	9
4.1.1. Shunt Method Setting Solder Jumper (SJP1, SJP2, SJP3, SJP4)	9
4.1.2. Motor Power Input Connector (J1)	9
4.1.3. Motor Connector (J2)	10
4.1.4. Control Power Input Connectors (J3, J10)	10
4.1.5. Switches and LEDs (S_SW1 to 4, LED1 to 3, LEDP1 to 2)	11
4.1.6. Potentiometer (VR1)	12
4.1.7. External MCU Connector (J7)	13
4.1.8. External DAC Connector (J4)	13
4.1.9. Debugger Connector (J5)	14
4.2. Operation Check	15
4.2.1. Preparation	15
4.2.2. Operation Method	15
4.2.3. Operation when Abnormality is Detected	15
4.3. Precautions for Use	15

1. Introduction

This reference guide (hereinafter referred to as "this guide") explains the specifications and steps of operation of DC 300 V Input BLDC Motor Sensorless Control Circuit (hereinafter referred to as "this reference design").

The fan of indoor unit of air conditioners is run using a brushless motor generally driven at a DC 300 V level. Previously, motors were driven mainly by square-wave energization using Hall sensors, etc., but in recent years, in response to demands for lower system costs, higher efficiency, and quieter motors, motors have been driven by sinusoidal energization without the use of Hall sensors and with vector control.

In this reference design, a microcontroller [TMPM374FWUG](#) is used for controlling the motor, and for implementing sensorless vector control.

An intelligent power device consisting of a switch for a three-phase inverter and a gate driver in a compact package is used for driving the motor. This reference design (RD179-4) uses a [TPD4165K](#) (IGBT built-in type, withstanding voltage of 600 V, maximum output current of 3.0 A, and HDIP30 package). This device help in achieving a high-efficiency motor drive with a compact board mounting area.

2. Specifications

Table 2.1 lists the main specifications of this reference design.

Table 2.1 DC 300 V Input BLDC Motor Sensorless Control Circuit Specifications

Item	Specifications
Motor Power Input	DC 120 V to 340 V
Control Power Input	DC 15 V, DC 5 V
Motor Drive Maximum Current (per Phase)	3.0 A
Motor Drive System	Sensorless Vector Control (Speed Control)
Switching Frequency	15.625 kHz (changeable by software)
MCU Control Method	Single MCU Control or External MCU Control
Cooling System	Natural Air Cooling
Protective Function	Overcurrent of Motor Power Input (10 A by Fuse) Overcurrent of Motor Output (Approx. 2.9A each phase)
Board Size (Including the Accessory Board Part)	130 x 85 x 53.4 mm
Board Configuration	2 layers, 70μm copper thickness
I/O Interface (Mounted on Accessory Board)	Red LED for Status Display x 3 DIP Switches for Status Setting x 4 Potentiometer for Speed Setting x 1 SWD Input/Output x 1

2.1. Circuit Block Diagrams

Fig. 2.1 shows the block diagram of this reference design.

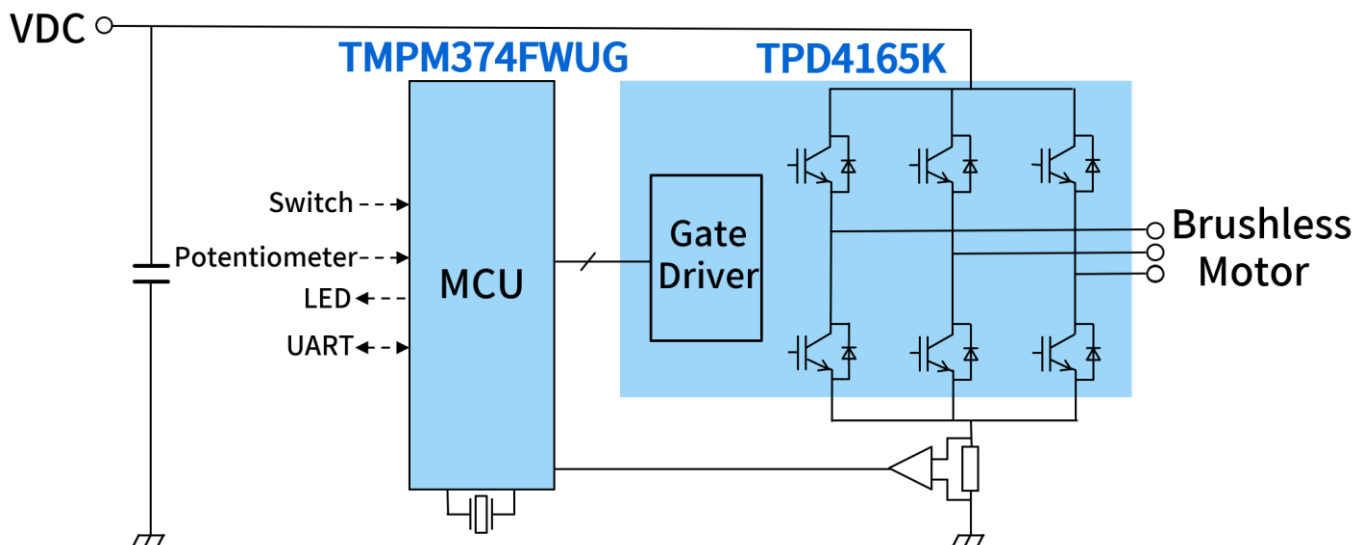

Fig. 2.1 DC 300 V Input BLDC Motor Sensorless Control Circuit Block Diagram

2.2. External View and Component Layout

Fig. 2.2 shows the external appearance of this reference design, and Fig. 2.3 and Fig. 2.4 show the layout of main components.

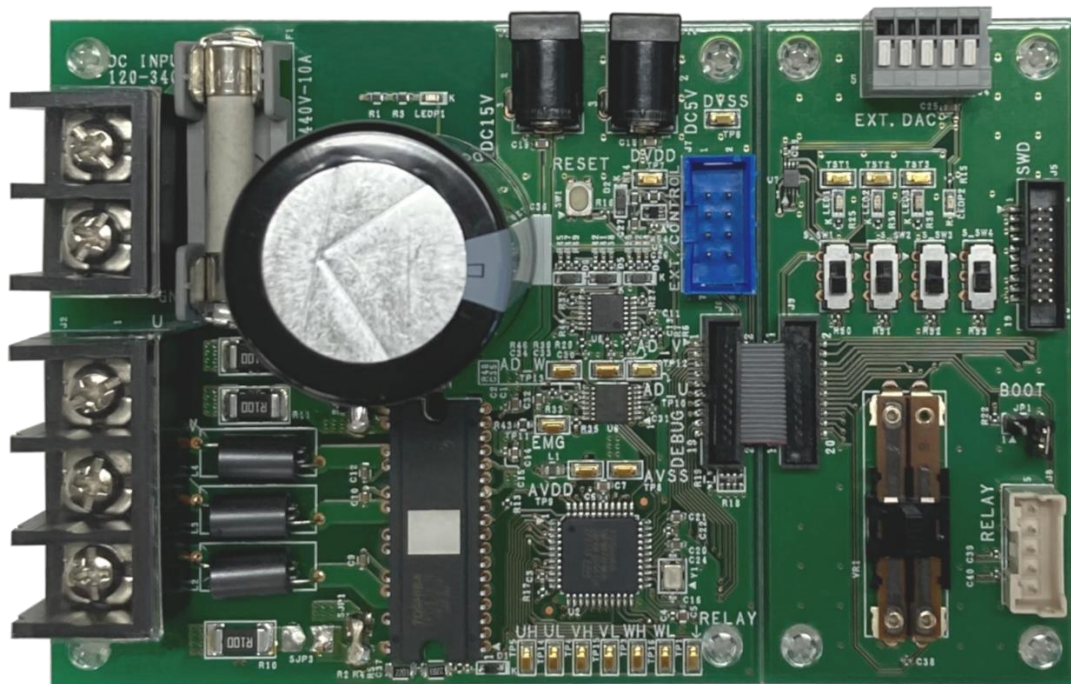

Fig. 2.2 DC 300 V Input BLDC Motor Sensorless Control Circuit Board Front View (For RD179-4)

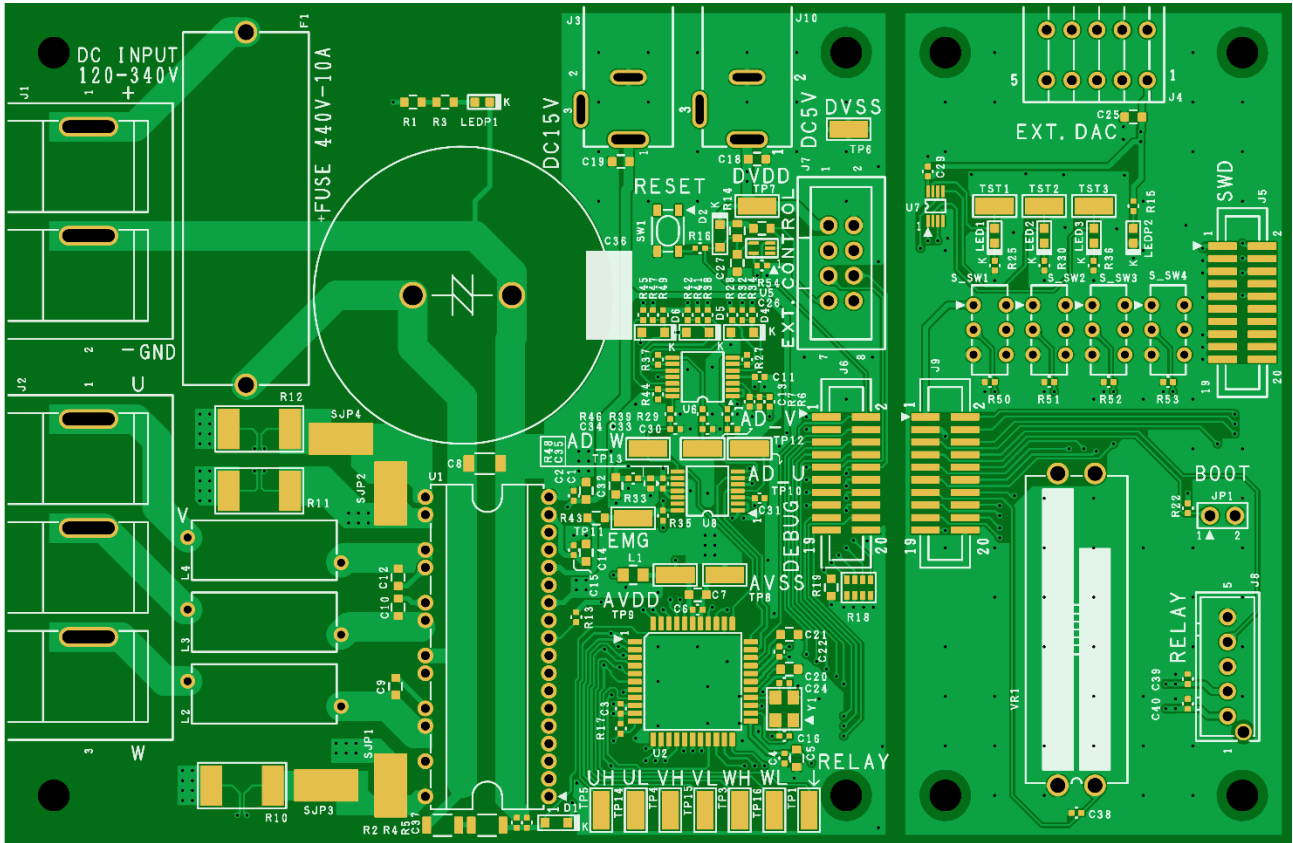

Fig. 2.3 Component Layout (for RD179-4, Front side)

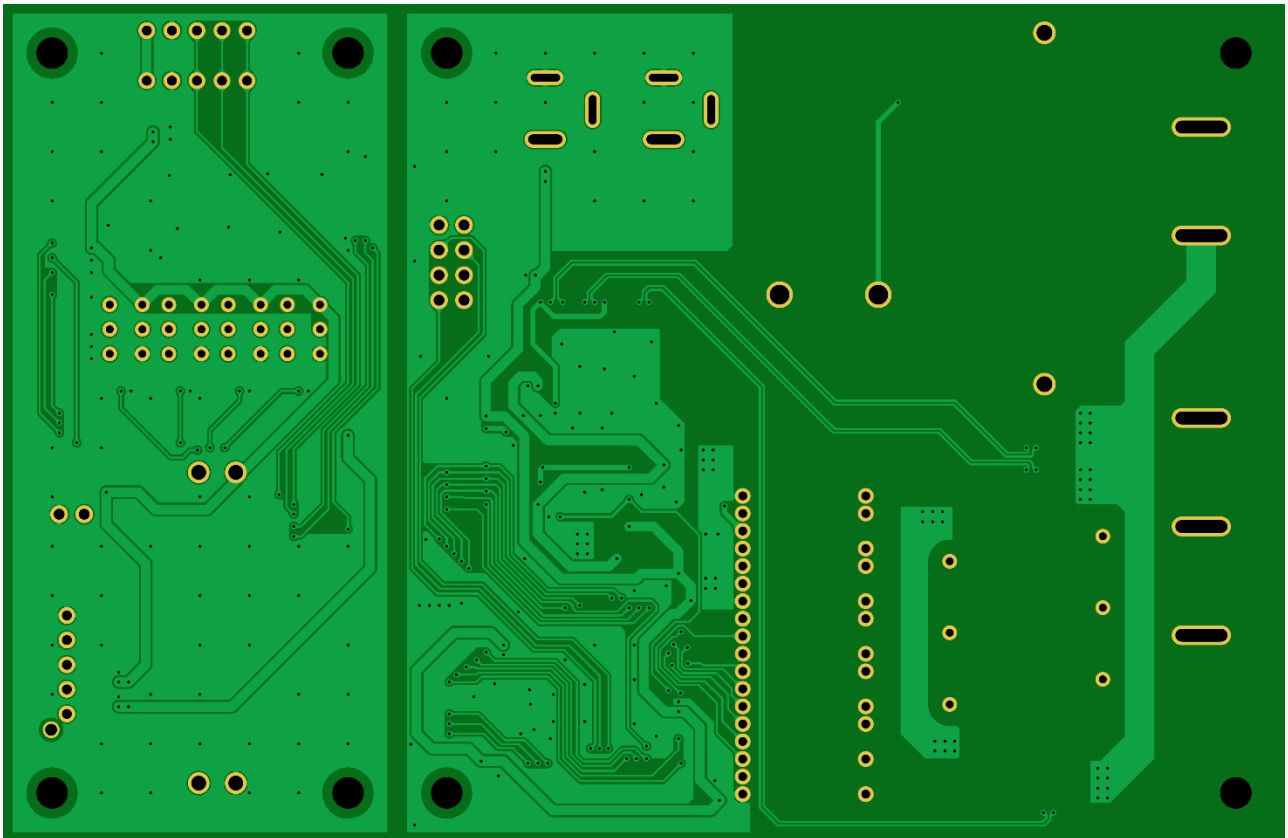

Fig. 2.4 Component Layout (for RD179-4, Back side)

3. Circuit Diagram, Bills of Material, and PCB Pattern Diagram

3.1. Circuit Diagram

Refer the following file:

RD179-4 (equipped with TPD4165K): RD179-SCHEMATIC4-xx.pdf
(xx is the revision number)

3.2. Component List

Refer the following file:

RD179-4 (equipped with TPD4165K): RD179-BOM4-xx.pdf
(xx is the revision number)

3.3. PCB Pattern Diagram

Fig. 3.1 shows the PCB pattern diagrams of this reference design.

Also refer to the following file:

RD179-4 (equipped with TPD4165K): RD179-LAYER4-xx.pdf
(xx is the revision number)

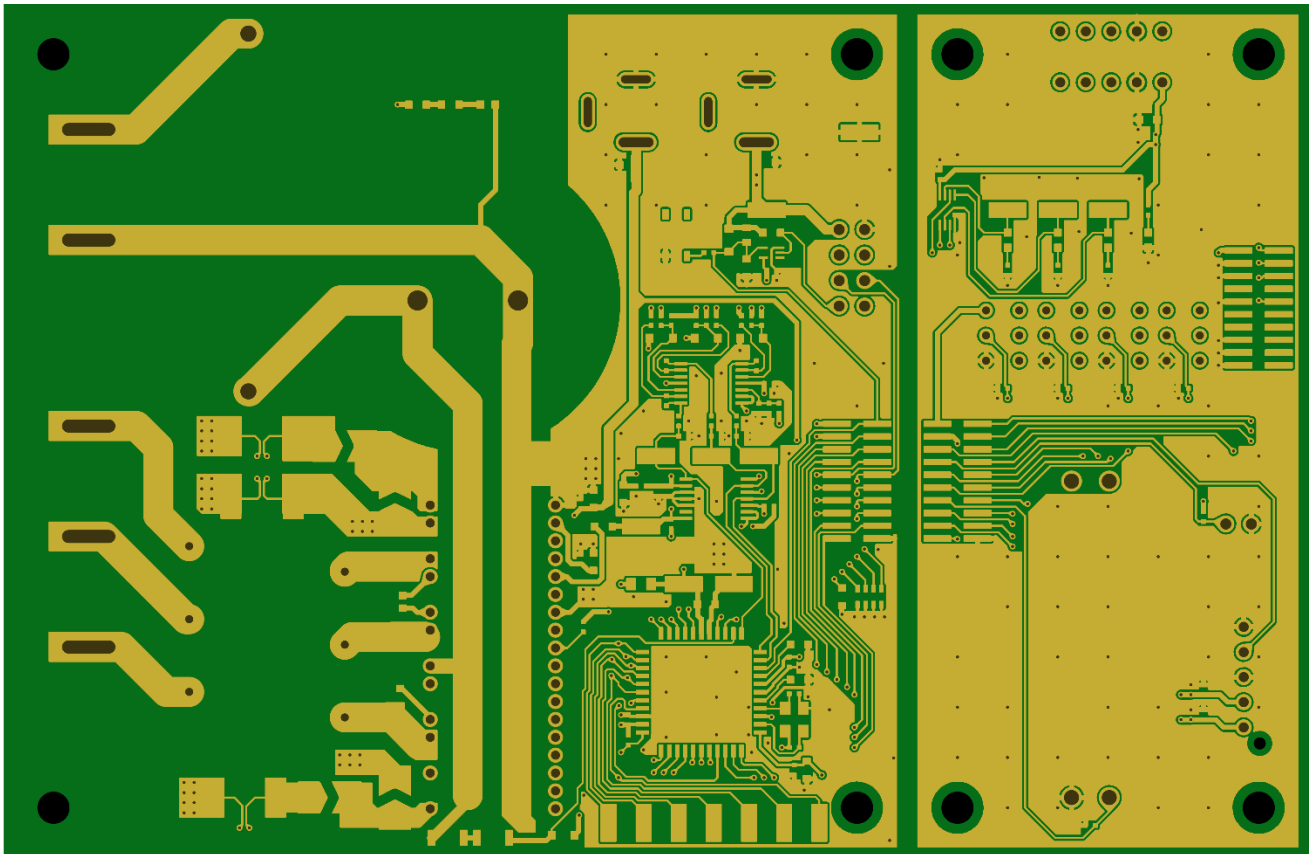

<Layer 1, Front side>

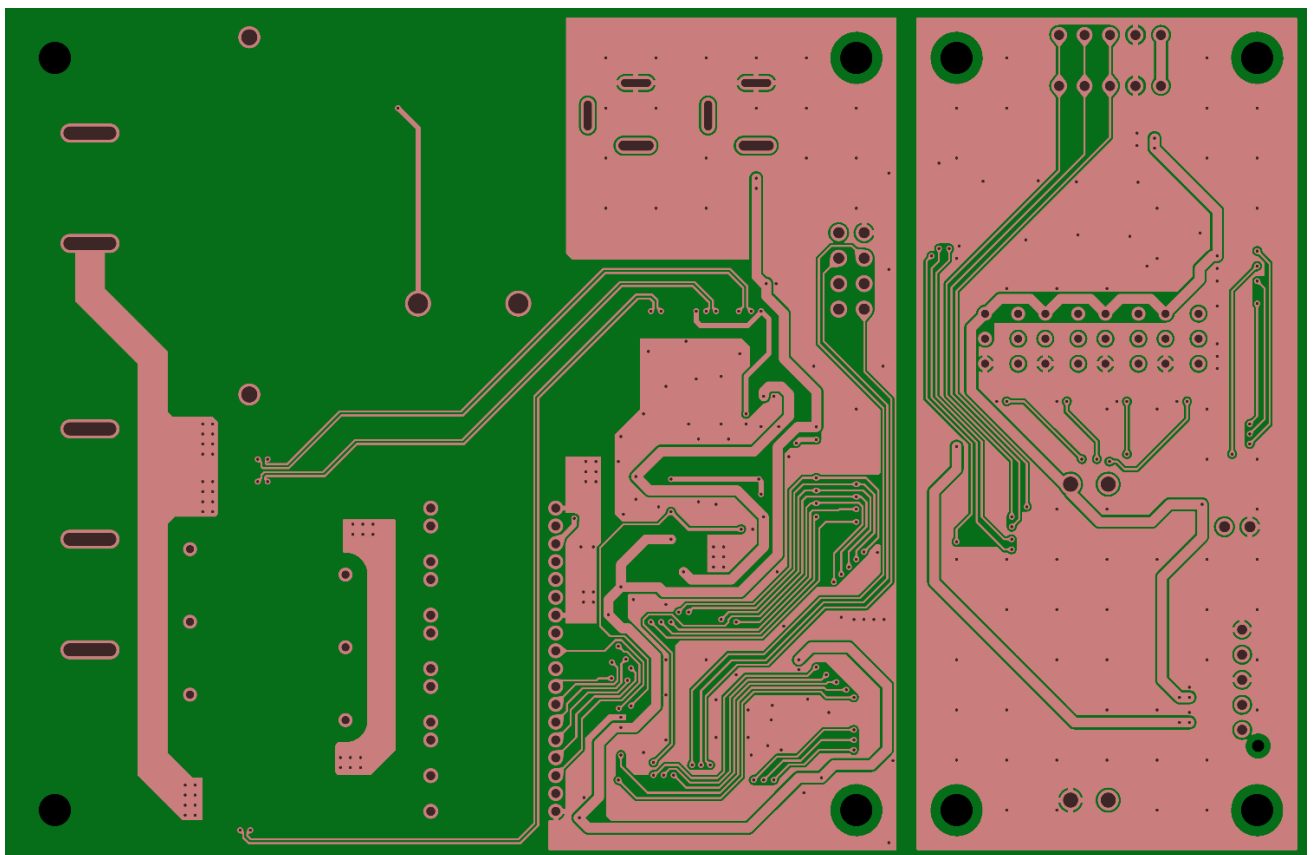

<Layer 2, Back side>

Fig. 3.1 Board Pattern Diagram (for RD179-4, Front View)

4. Description of Circuit Operation

4.1. Name and Function of Components

4.1.1. Shunt Method Setting Solder Jumper (SJP1, SJP2, SJP3, SJP4)

To switch the current detection method, set four solder jumpers as described below.

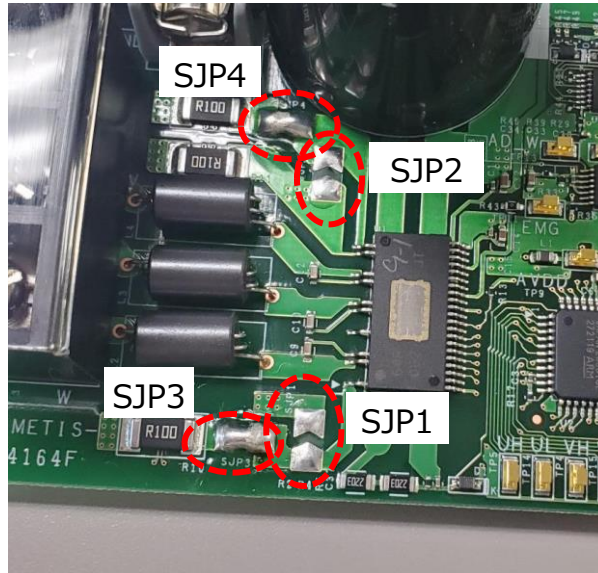

Fig. 4.1 Solder Jumpers on the Board

Table 4.1 Solder Jumper Settings

Current Detection System	SJP1	SJP2	SJP3	SJP4
3-shunt system	Open	Open	Short	Short
1-shunt system	Short	Short	Open	Open

4.1.2. Motor Power Input Connector (J1)

Used for input DC power to drive the motor.



Fig. 4.2 Motor Power Input Connector on Board (J1)

4.1.3. Motor Connector (J2)

Used for connecting a 3-phase BLDC motor.

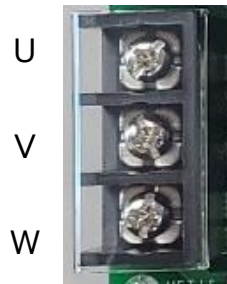

Fig. 4.3 Motor Connector on Board (J2)

4.1.4. Control Power Input Connectors (J3, J10)

Used for supplying Input power for control. The connector is a jack-type connector (inner positive polarity) so that it can be supplied using an AC adapter, etc. J3 is for 15 V input and is used to operate Intelligent Power Device (TPD4165K). And, J10 is for 5 V input and is used as a power supply for MCU, peripheral IC, etc. Since both Connectors are of same type, be careful not to connect them incorrectly.

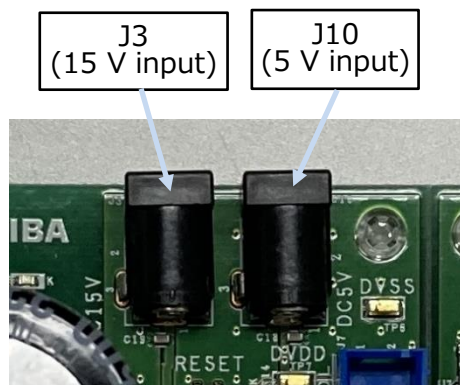

Fig. 4.4 Control Power Input Connectors (J3, J10) on the Board

4.1.5. Switches and LEDs (S_SW1 to 4, LED1 to 3, LEDP1 to 2)

Switches and LEDs operate as follows.

S_SW1, S_SW2, S_SW3, S_SW4, LED1, LED2, LED3 are connected to the GPIO pins of the MCU and are controlled by software.

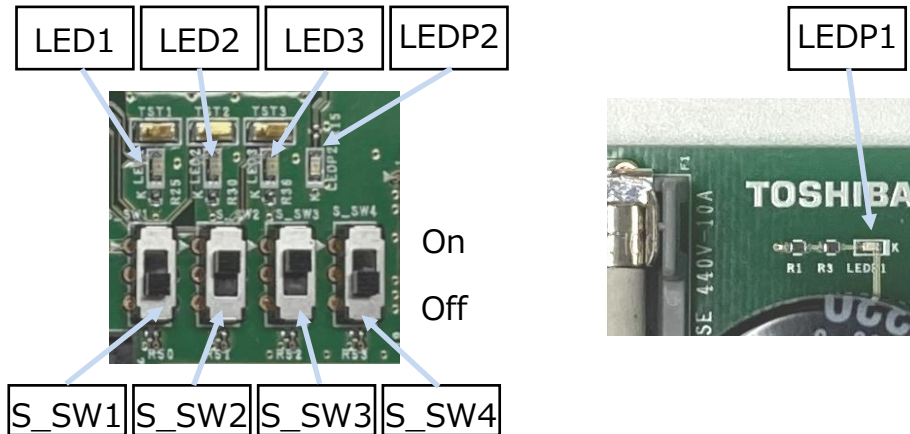

Fig. 4.5 Switches and LEDs on the Board

Table 4.2 Switch and LED Specifications

Component	Function	Remark
S_SW1	(not used)	
S_SW2	MCU Control Method	On: External MCU control, Off: Single MCU control (It should be set to Off in this reference design.)
S_SW3	Motor Rotation Direction	On: CW (clockwise), Off: CCW (counterclockwise)
S_SW4	(Not used)	
LED1	Error Indicator	No Error: Off Error: On or Blink
LED2	Vector Engine Indicator	VE Interrupt in progress: On
LED3	Communication Indicator	Communicating: On Communication stopped due to error: Blinks every 0.5 seconds
LEDP1	Motor Power ON Indicator	When motor power is ON: On (yellow) LEDP1 also On while the capacitor is charged. Be careful not to touch the board while it is On.
LEDP2	Control Power Supply Energization Indicator	Control power (5 V) energized: On (green)

4.1.6. Potentiometer (VR1)

The potentiometer can be used to set the motor speed (cHZ_MIN to 60 Hz range).

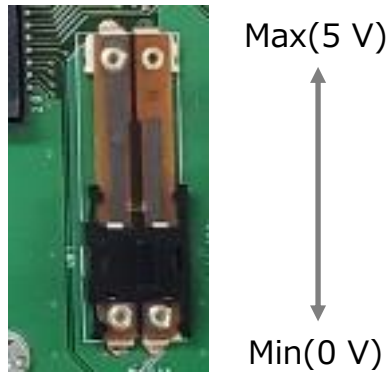

Fig. 4.6 Potentiometer on Board (VR1)

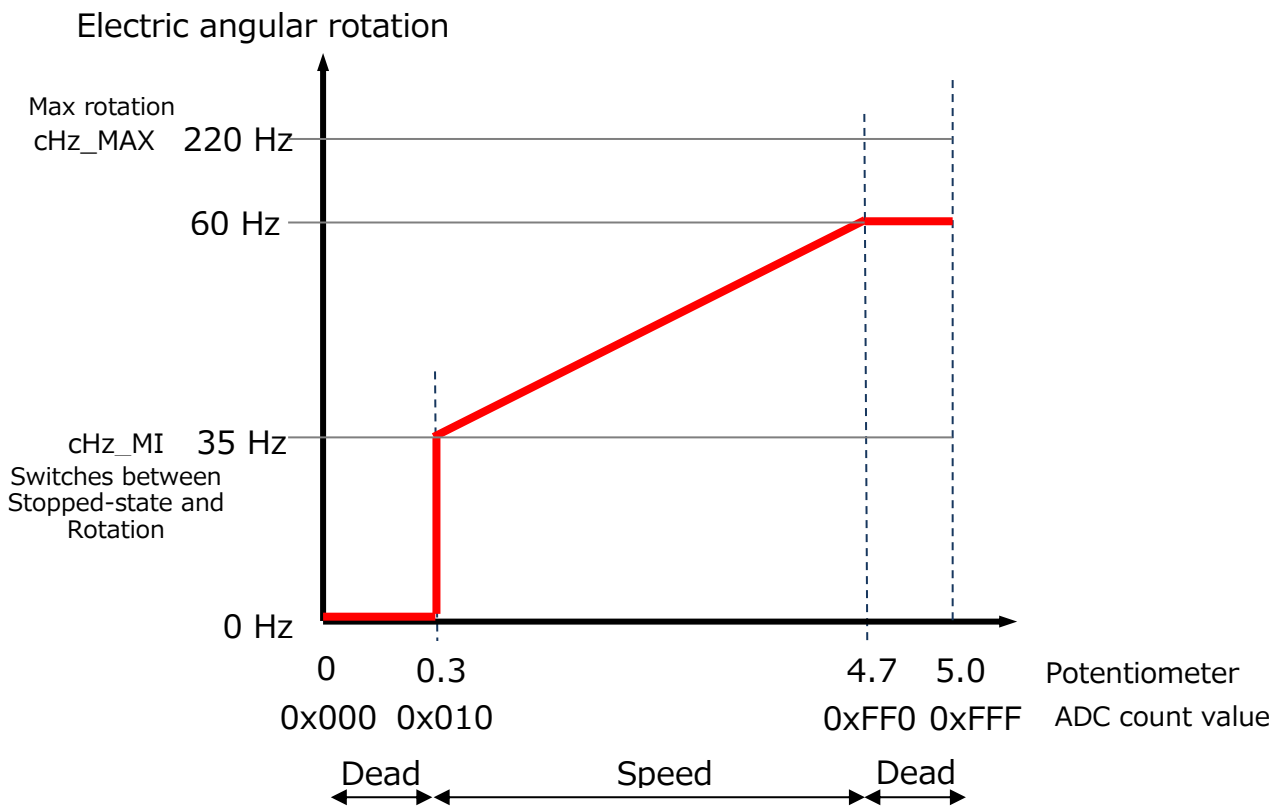

Fig. 4.7 Relationship between potentiometer setting value and rotational speed

4.1.7. External MCU Connector (J7)

Connector for connecting to an external (host) MCU. Not used in this reference design.

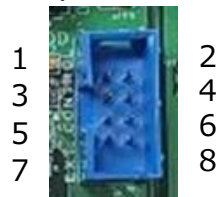

Fig. 4.8 External MCU Connector (J7)

Table 4.3 External MCU Connector Specifications

Pin		Function	Remark
1	DVDD	Digital power supply (5 V)	
2	DVS	Digital power supply (GND)	
3	UART_RX	UART Reception	
4	UART_TX	UART Transmission	
5	GPIO connection	Reserved (not used)	Same as S_SW1
6	GPIO connection	Control mode	Same as S_SW2
7	RESET#	Reset input	To MCU reset
8	GPIO connection	Reserved (not used)	GPIO connection

4.1.8. External DAC Connector (J4)

The data to be processed inside the MCU is output as serial data. By connecting an external DAC, the processing data can be checked as a waveform using an oscilloscope, etc.



Fig. 4-9 External DAC Connector (J4)

Table 4.4 External DAC Connector Specifications

Pin		Function	Remarks
1	DVDD	5 V power output	
2	GND	GND	
3	SYNC	DAC sync signal	Uses GPIO
4	SDO	DAC data	Uses SIO
5	SCLK	DAC clock	Uses SIO

4.1.9. Debugger Connector (J5)

20-pin connector for connecting to the emulator/debugger probe. It conforms to MIPI-20 connector standard and supports only SWD interface.

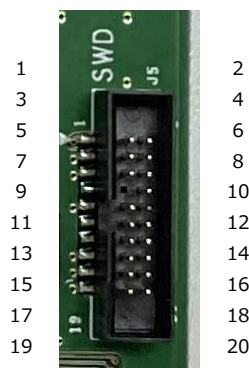

Fig. 4.10. Debugger Connector (J5)

Table 4.5 Debugger Connector Specifications

Pin	Function	Pin	Function
1	VDD(5 V)	2	SWDIO
3	GND	4	SWCLK
5	GND	6	SWV
7	(n.c.)	8	(n.c.)
9	GND	10	RESET
11	(n.c.)	12	(n.c.)
13	(n.c.)	14	(n.c.)
15	GND	16	(n.c.)
17	GND	18	(n.c.)
19	GND	20	(n.c.)

4.2. Operation Check

4.2.1. Preparation

Connect a 3-phase BLDC motor to the motor connector (J2). Connect the DC power supply to the motor power input connector (J1). Set switch S_SW2 (MCU control method) on the board to Off (single MCU control). Turn on the power in following order: control power (5 V) input connector (J10) → control power (15 V) input connector (J13) → motor power input connector (J1).

4.2.2. Operation Method

The motor is in stopped state when the potentiometer (VR1) is in Min-position (0 Hz). The motor can be started by raising the potentiometer (VR1) setting from the Min-position (0 Hz). If the motor is stopped when the potentiometer is not in the MIN position, change VR1 to the Min position once. While in stopped state, LED1, LED2, LED3 are turned off.

After motor operation starts, the speed can be varied by using VR1. The closer VR1 is to the Max position (60 Hz), the faster the rotational speed. The closer it is to the Min position, the slower the rotational speed. When S_SW3 (rotation direction) is On, the motor rotates in CW (clockwise) direction and when it is Off, the motor rotates in CCW (counterclockwise) direction.

4.2.3. Operation when Abnormality is Detected

If following error is detected, the system enters in EMG (Emergency) state, the motor stops and the LED1 either blinks or turns on.

(1) Abnormal voltage detection: When abnormal voltage is detected, LED1 blinks in 250 ms cycles.

(2) Abnormal current detection: When abnormal current is detected, LED1 blinks in 500 ms cycles.

(3) Software overcurrent detection: When overcurrent is detected using software processing, LED1 blinks in 1 s cycles.

(4) Hardware overcurrent detection: When overcurrent is detected using MCU hardware function, LED1 turns on.

The EMG status is canceled by lowering VR1 to the MIN-position.

4.3. Precautions for Use

Pay special attention to the following when operating.

- Jumper setting before energizing must be confirmed. Especially the 3-shunt/1-shunt solder jumper setting must be checked.
- Polarity of connectors and terminals must be correct.
- The smoothing capacitor on the motor power supply takes approximately 10 minutes to get fully discharged. Even after the power is turned off, the board must not be touched until LEDP1 turns off.
- During the operation, the BOARD must be covered with an acrylic case for safety.

Terms of Use

This terms of use is made between Toshiba Electronic Devices and Storage Corporation ("We") and Customer who downloads or uses this Reference Design. Customer shall comply with this terms of use. This Reference Design means all documents and data in order to design electronics applications on which our semiconductor device is embedded.

Section 1. Restrictions on usage

1. This Reference Design is provided solely as reference data for designing electronics applications. Customer shall not use this Reference Design for any other purpose, including without limitation, verification of reliability.
2. Customer shall not use this Reference Design for sale, lease or other transfer.
3. Customer shall not use this Reference Design for evaluation in high or low temperature, high humidity, or high electromagnetic environments.
4. This Reference Design shall not be used for or incorporated into any product or system whose manufacture, use, or sale is prohibited under any applicable laws or regulations.

Section 2. Limitations

1. We reserve the right to make changes to this Reference Design without notice.
2. This Reference Design should be treated as a reference only. WE ARE NOT RESPONSIBLE FOR ANY INCORRECT OR INCOMPLETE DATA AND INFORMATION.
3. Semiconductor devices can malfunction or fail. When designing electronics applications by referring to this Reference Design, Customer is responsible for complying with safety standards and for providing adequate designs and safeguards for their hardware, software and systems which minimize risk and avoid situations in which a malfunction or failure of semiconductor devices could cause loss of human life, bodily injury or damage to property, including data loss or corruption. Customer must also refer to and comply with the latest versions of all relevant our information, including without limitation, specifications, data sheets and application notes for semiconductor devices, as well as the precautions and conditions set forth in the "Semiconductor Reliability Handbook".
4. Designing electronics applications by referring to this Reference Design, Customer must evaluate the whole system sufficiently. Customer is solely responsible for applying this Reference Design to Customer's own product design or applications. WE ASSUME NO LIABILITY FOR CUSTOMER'S PRODUCT DESIGN OR APPLICATIONS.
5. WE SHALL NOT BE RESPONSIBLE FOR ANY INFRINGEMENT OF PATENTS OR ANY OTHER INTELLECTUAL PROPERTY RIGHTS OF THIRD PARTIES THAT MAY RESULT FROM THE USE OF THIS REFERENCE DESIGN. NO LICENSE TO ANY INTELLECTUAL PROPERTY RIGHT IS GRANTED BY THIS TERMS OF USE, WHETHER EXPRESS OR IMPLIED, BY ESTOPPEL OR OTHERWISE.
6. THIS REFERENCE DESIGN IS PROVIDED "AS IS". WE (a) ASSUME NO LIABILITY WHATSOEVER, INCLUDING WITHOUT LIMITATION, INDIRECT, CONSEQUENTIAL, SPECIAL, OR INCIDENTAL DAMAGES OR LOSS, INCLUDING WITHOUT LIMITATION, LOSS OF PROFITS, LOSS OF OPPORTUNITIES, BUSINESS INTERRUPTION AND LOSS OF DATA, AND (b) DISCLAIM ANY AND ALL EXPRESS OR IMPLIED WARRANTIES AND CONDITIONS RELATED TO THIS REFERENCE DESIGN, INCLUDING WITHOUT LIMITATION, WARRANTIES OR CONDITIONS OF FUNCTION AND WORKING, WARRANTIES OF MERCHANTABILITY, FITNESS FOR A PARTICULAR PURPOSE, ACCURACY OF INFORMATION, OR NONINFRINGEMENT.

Section 3. Terms and Termination

It is assumed that Customer agrees to any and all this terms of use if Customer downloads or uses this Reference Design. We may, at its sole and exclusive discretion, change, alter, modify, add, and/or remove any part of this terms of use at any time without any prior notice. We may terminate this terms of use at any time and without any cause. Upon termination of this terms of use, Customer shall eliminate this Reference Design. Furthermore, upon our request, Customer shall submit to us a written confirmation to prove elimination of this Reference Design.

Section 4. Export Control

Customer shall not use or otherwise make available this Reference Design for any military purposes, including without limitation, for the design, development, use, stockpiling or manufacturing of nuclear, chemical, or biological weapons or missile technology products (mass destruction weapons). This Reference Design may be controlled under the applicable export laws and regulations including, without limitation, the Japanese Foreign Exchange and Foreign Trade Act and the U.S. Export Administration Regulations. Export and re-export of this Reference Design is strictly prohibited except in compliance with all applicable export laws and regulations.

Section 5. Governing Laws

This terms of use shall be governed and construed by laws of Japan, without reference to conflict of law principle.

Section 6. Jurisdiction

Unless otherwise specified, Tokyo District Court in Tokyo, Japan shall be exclusively the court of first jurisdiction for all disputes under this terms of use.