

TOSHIBA CMOS Linear Integrated Circuit Silicon Monolithic

TCWA1225G

1. RF SPDT Switch

High power antenna Switch

2. Features

TarfSOI™

GPIO Control I/F

Wide band (0.7-5.0 GHz)

Low Insertion Loss

WCSP package (1.9 mm×1.9 mm)

3. Pad Assignment

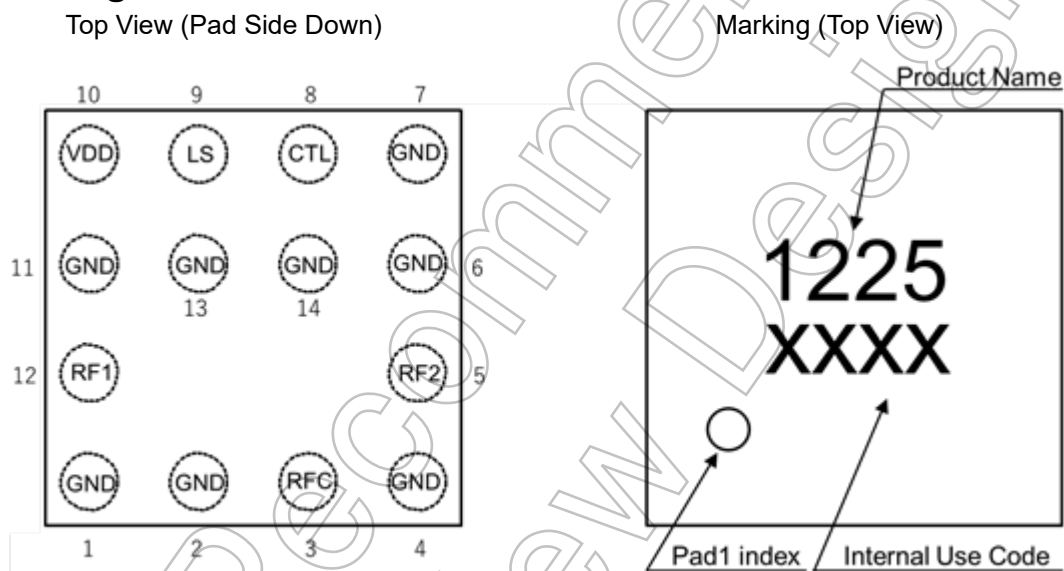

Figure 1 Pad Assignment

Figure 2 Marking

4. Notice

This device is sensitive to electrostatic discharge. Please ensure equipment and tools are adequately earthed when handling.

TarfSOI™ (Toshiba advanced RF SOI) is a trademark of TOSHIBA CORPORATION

Start of commercial production
2024-04

5. Block Diagram

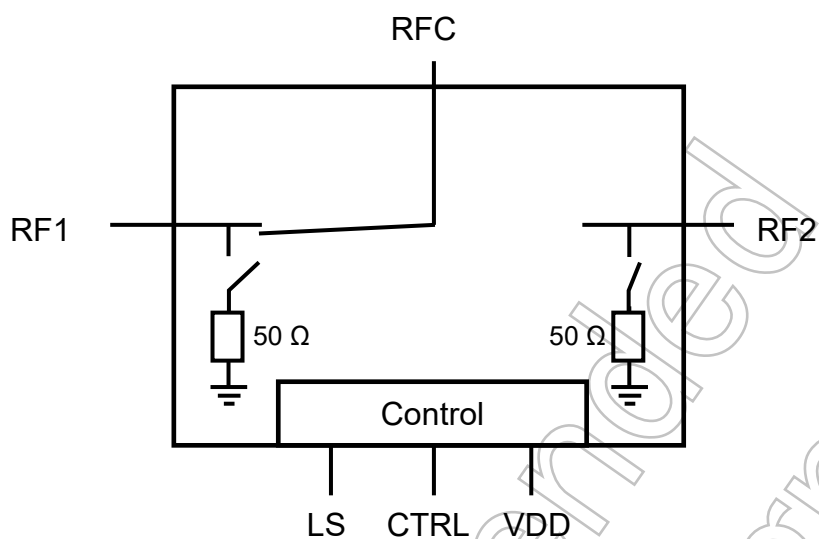

Figure 3 Function Block Diagram

6. Control Logic

Table 1 Control Logic

LS	CTRL	RFC-RF1	RFC-RF2
0	0	OFF	ON
0	1	ON	OFF
1	0	ON	OFF
1	1	OFF	ON

7. Pad Description

Table 2 Pad Description

Pad No.	Symbol	Description
1	GND	Ground
2	GND	Ground
3	RFC	RF common port
4	GND	Ground
5	RF2	RF port2
6	GND	Ground
7	GND	Ground
8	CTRL	Control
9	LS	Logic select
10	VDD	Voltage Supply
11	GND	Ground
12	RF1	RF port1
13	GND	Ground
14	GND	Ground

8. Absolute Maximum Ratings (Note)

Ta = +25 °C, otherwise noted.

Table 3 Absolute Maximum Ratings

Item	Symbol	Rating	Unit	
Supply Voltage Range	V _{DD}	-0.3 to 3.9	V	
Logic Input (LS, CTRL Pad)	V _I	-0.3 to 3.9	V	
Peak Power Handling (8 dB PAR)	P _{pk}	46	dBm	
50 Ω Termed Port Power Handling (CW)	P _{TP}	24	dBm	
Power Disipation	Tc = +25 °C	PD ₂₅	1.015	W
	Tc = +95 °C	PD ₉₅	0.305	W
Storage Temperature Range	T _{stg}	-40 to 150	°C	
Junction Temperature	T _j	125	°C	

Note1: Exceeding any of the absolute maximum ratings, even briefly, lead to deterioration in IC performance or even destruction.

Note 2: Using continuously under heavy loads (e.g. the application of high temperature/ current/ voltage and the significant change in temperature, etc.) may cause this product to decrease in the reliability significantly even if the operating conditions (i.e. operating temperature/ current/ voltage, etc.) are within the absolute maximum ratings and the operating ranges.

Please design the appropriate reliability upon reviewing the Toshiba Semiconductors Reliability Handbook (“Handling Precautions”/ “Derating Concept and Methods”) and individual reliability data (i.e. reliability test Report and estimated failure rate, etc.).

9. Operating Ranges (Note)

Table 4 Operating Ranges

Item	Symbol	Min	Typ.	Max	Unit	
Supply Voltage	V _{DD}	3.0	3.3	3.6	V	
Logic Input Voltage	High Level	V _{IH}	1.65	-	3.6	V
	Low Level	V _{IL}	-0.3	-	0.4	V
Operation Temperature	T _{opr}	-40	25	95	°C	

Note 3: The operating ranges should be maintained to ensure the normal operation of the device.

10. Electrical Characteristics

10.1. DC Characteristics

Ta = +25 °C

Table 5 DC Characteristics

Item	Symbol	Test Condition	Min	Typ.	Max	Unit
Power Consumption Current	I _{DC}	V _{DD} = 3.6 V	-	50	200	μA

10.2. AC Characteristics

Ta = +25 °C, V_{DD} = 3.0 to 3.6 V, V_{IH} = 3.3 V, V_{IL} = 0 V

Table 6 AC Characteristics

Item	Symbol	Test Condition	Min	Typ.	Max	Unit
Switching time	T _{sw}	50 % CTRL to 10 % or 90 % of final value of RF signal	-	750	1500	ns

Not Recommended for New Design

11. RF Characteristics1

T_a = +25 °C, V_{DD} = 3.0 to 3.6 V, V_{IH} = 3.3 V, V_{IL} = 0 V, Z_s = Z_l = 50 Ω, CW signal

Table 7 RF Characteristics1

Item	Symbol	Path	Test Condition	Min	Typ.	Max	Unit
Insertion loss	IL	RFC to RFX	0.7 to 3 GHz	-	0.5	0.7	dB
		RFC to RFX	3 to 5 GHz	-	0.6	0.9	dB
Isolation	ISO	RFC to RFX	0.7 to 3 GHz	45	50	-	dB
		RFC to RFX	3 to 5 GHz	41	46	-	dB
VSWR	VSWR	VSWR of RFX	0.7 to 5 GHz, RF1/2 ON-State	-	1.2	1.4	-
Input 1dB compression	IP1dB	RFC to RFX	at 2.6 GHz, Duty ratio 5 %	38.5	47.0	-	dBm
Input IP3	IIP3	RFC to RFX	2.6 GHz, 24 dBm	66.5	74.0	-	dBm
Input IP2	IIP2	RFC to RFX	2.6 GHz, 24 dBm	119	128	-	dBm

12. RF Characteristics2

T_c = -40 to +95 °C, V_{DD} = 3.0 to 3.6 V, V_{IH} = 3.3 V, V_{IL} = 0 V, Z_s = Z_l = 50 Ω, CW signal

Table 8 RF Characteristics2

Item	Symbol	Path	Test Condition	Min	Typ.	Max	Unit
Insertion loss	IL	RFC to RFX	0.7 to 3 GHz	-	-	0.8	dB
		RFC to RFX	3 to 5 GHz	-	-	1.0	dB
Isolation	ISO	RFC to RFX	0.7 to 3 GHz	43	-	-	dB
		RFC to RFX	3 to 5 GHz	39	-	-	dB
VSWR	VSWR	VSWR of RFX	0.7 to 5 GHz, RF1/2 ON-State	-	-	1.5	-
Input 1dB compression	IP1dB	RFC to RFX	at 2.6 GHz, Duty ratio 5 %	38	-	-	dBm
Input IP3	IIP3	RFC to RFX	2.6 GHz, 24 dBm	65	-	-	dBm
Input IP2	IIP2	RFC to RFX	2.6 GHz, 24 dBm	116	-	-	dBm

13. Packaging Dimensions

Unit : mm

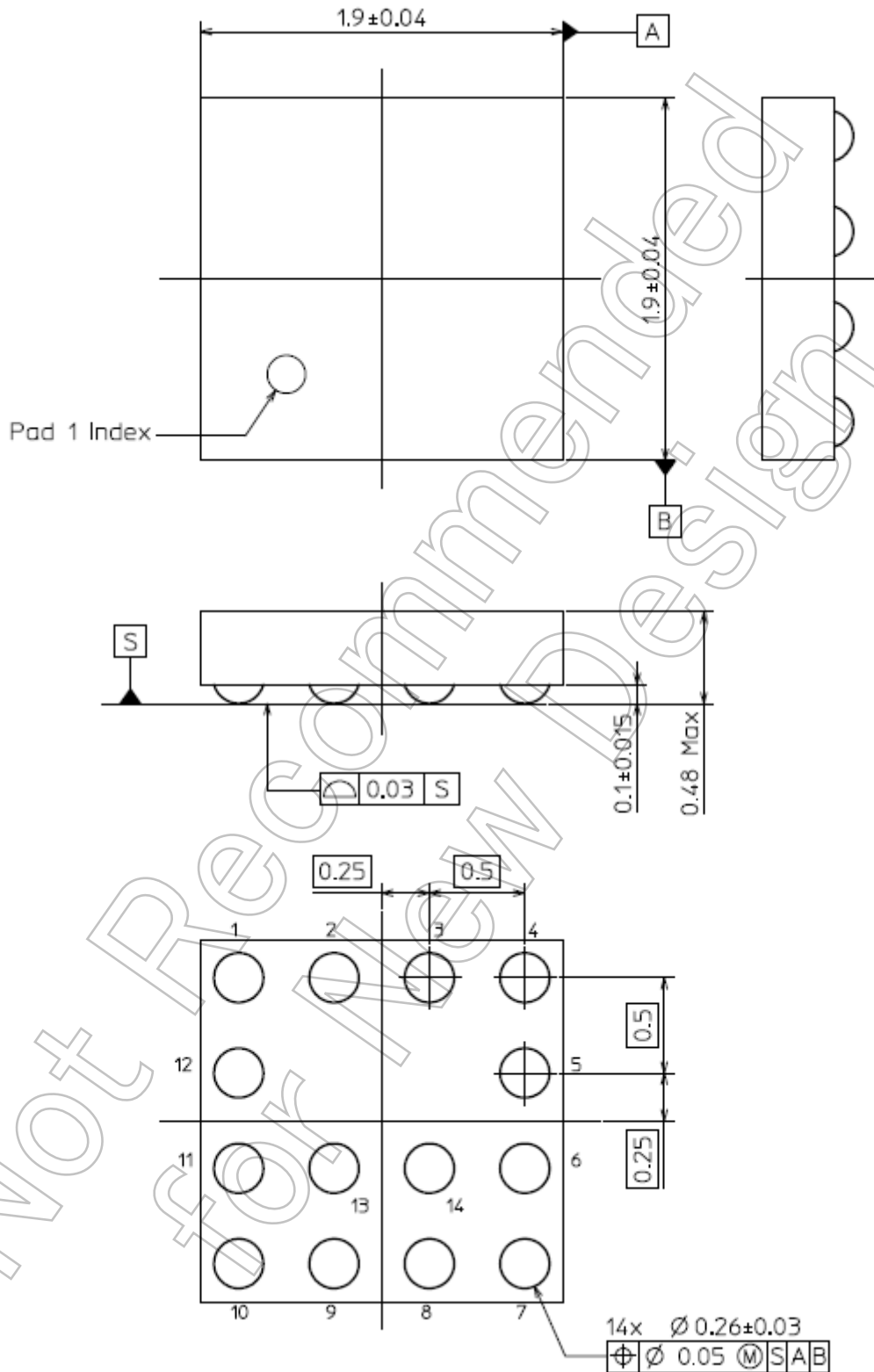

Weight: 3.3 mg (typ.)

14. Land pattern dimensions for reference only

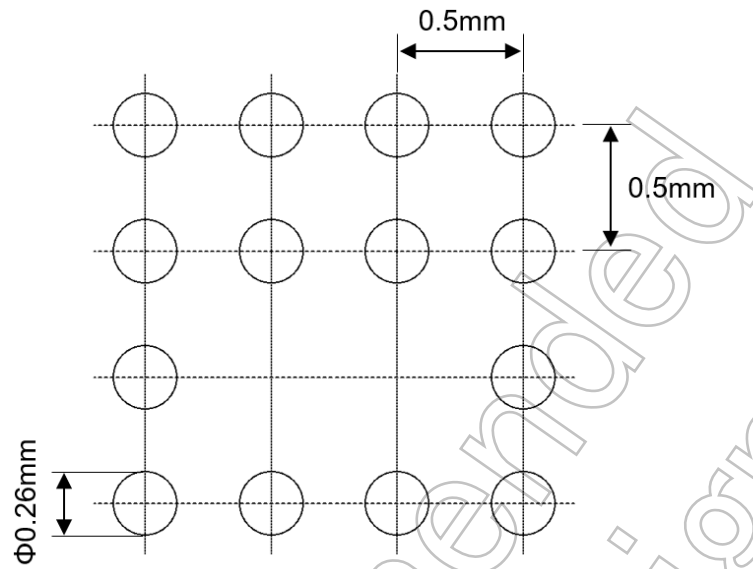

Not Recommended for New Design

RESTRICTIONS ON PRODUCT USE

Toshiba Corporation and its subsidiaries and affiliates are collectively referred to as "TOSHIBA". Hardware, software and systems described in this document are collectively referred to as "Product".

- TOSHIBA reserves the right to make changes to the information in this document and related Product without notice.
- This document and any information herein may not be reproduced without prior written permission from TOSHIBA. Even with TOSHIBA's written permission, reproduction is permissible only if reproduction is without alteration/omission.
- Though TOSHIBA works continually to improve Product's quality and reliability, Product can malfunction or fail. Customers are responsible for complying with safety standards and for providing adequate designs and safeguards for their hardware, software and systems which minimize risk and avoid situations in which a malfunction or failure of Product could cause loss of human life, bodily injury or damage to property, including data loss or corruption. Before customers use the Product, create designs including the Product, or incorporate the Product into their own applications, customers must also refer to and comply with (a) the latest versions of all relevant TOSHIBA information, including without limitation, this document, the specifications, the data sheets and application notes for Product and the precautions and conditions set forth in the "TOSHIBA Semiconductor Reliability Handbook" and (b) the instructions for the application with which the Product will be used with or for. Customers are solely responsible for all aspects of their own product design or applications, including but not limited to (a) determining the appropriateness of the use of this Product in such design or applications; (b) evaluating and determining the applicability of any information contained in this document, or in charts, diagrams, programs, algorithms, sample application circuits, or any other referenced documents; and (c) validating all operating parameters for such designs and applications. **TOSHIBA ASSUMES NO LIABILITY FOR CUSTOMERS' PRODUCT DESIGN OR APPLICATIONS.**
- **PRODUCT IS NEITHER INTENDED NOR WARRANTED FOR USE IN EQUIPMENTS OR SYSTEMS THAT REQUIRE EXTRAORDINARILY HIGH LEVELS OF QUALITY AND/OR RELIABILITY, AND/OR A MALFUNCTION OR FAILURE OF WHICH MAY CAUSE LOSS OF HUMAN LIFE, BODILY INJURY, SERIOUS PROPERTY DAMAGE AND/OR SERIOUS PUBLIC IMPACT ("UNINTENDED USE").** Except for specific applications as expressly stated in this document, Unintended Use includes, without limitation, equipment used in nuclear facilities, equipment used in the aerospace industry, Class 3 medical devices, equipment used for automobiles, and military vehicles and munitions. **IF YOU USE PRODUCT FOR UNINTENDED USE, TOSHIBA ASSUMES NO LIABILITY FOR PRODUCT.** For details, please contact your TOSHIBA sales representative or contact us via our website.
- Do not disassemble, analyze, reverse-engineer, alter, modify, translate or copy Product, whether in whole or in part.
- Product shall not be used for or incorporated into any products or systems whose manufacture, use, or sale is prohibited under any applicable laws or regulations.
- The information contained herein is presented only as guidance for Product use. No responsibility is assumed by TOSHIBA for any infringement of patents or any other intellectual property rights of third parties that may result from the use of Product. No license to any intellectual property right is granted by this document, whether express or implied, by estoppel or otherwise.
- **ABSENT A WRITTEN SIGNED AGREEMENT, EXCEPT AS PROVIDED IN THE RELEVANT TERMS AND CONDITIONS OF SALE FOR PRODUCT, AND TO THE MAXIMUM EXTENT ALLOWABLE BY LAW, TOSHIBA (1) ASSUMES NO LIABILITY WHATSOEVER, INCLUDING WITHOUT LIMITATION, INDIRECT, CONSEQUENTIAL, SPECIAL, OR INCIDENTAL DAMAGES OR LOSS, INCLUDING WITHOUT LIMITATION, LOSS OF PROFITS, LOSS OF OPPORTUNITIES, BUSINESS INTERRUPTION AND LOSS OF DATA, AND (2) DISCLAIMS ANY AND ALL EXPRESS OR IMPLIED WARRANTIES AND CONDITIONS RELATED TO SALE, USE OF PRODUCT, OR INFORMATION, INCLUDING WARRANTIES OR CONDITIONS OF MERCHANTABILITY, FITNESS FOR A PARTICULAR PURPOSE, ACCURACY OF INFORMATION, OR NONINFRINGEMENT.**
- Do not use or otherwise make available Product or related software or technology for any military purposes, including without limitation, for the design, development, use, stockpiling or manufacturing of nuclear, chemical, or biological weapons or missile technology products (mass destruction weapons). Product and related software and technology may be controlled under the applicable export laws and regulations including, without limitation, the Japanese Foreign Exchange and Foreign Trade Law and the U.S. Export Administration Regulations. Export and re-export of Product or related software or technology are strictly prohibited except in compliance with all applicable export laws and regulations.
- Please contact your TOSHIBA sales representative for details as to environmental matters such as the RoHS compatibility of Product. Please use Product in compliance with all applicable laws and regulations that regulate the inclusion or use of controlled substances, including without limitation, the EU RoHS Directive. **TOSHIBA ASSUMES NO LIABILITY FOR DAMAGES OR LOSSES OCCURRING AS A RESULT OF NONCOMPLIANCE WITH APPLICABLE LAWS AND REGULATIONS.**

Toshiba Electronic Devices & Storage Corporation

<https://toshiba.semicon-storage.com/>