

Air Conditioner

Solution Proposal by Toshiba

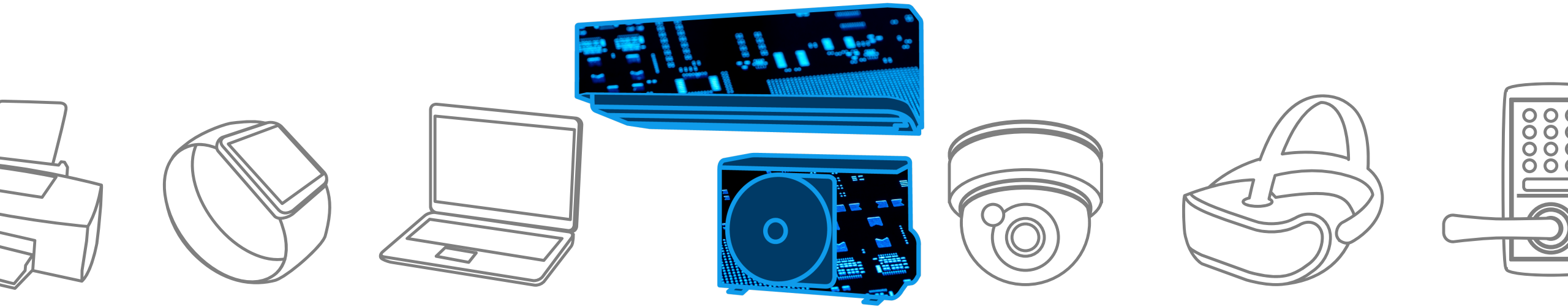

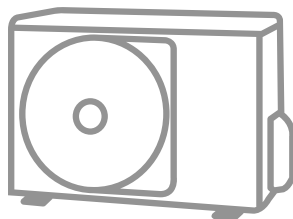
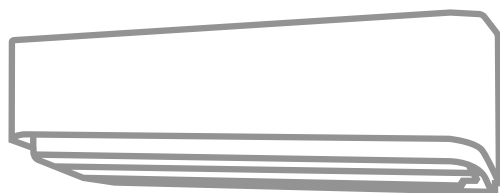

Toshiba Electronic Devices & Storage Corporation provides comprehensive device solutions to customers developing new products by applying its thorough understanding of the systems acquired through the analysis of basic product designs.

Block Diagram

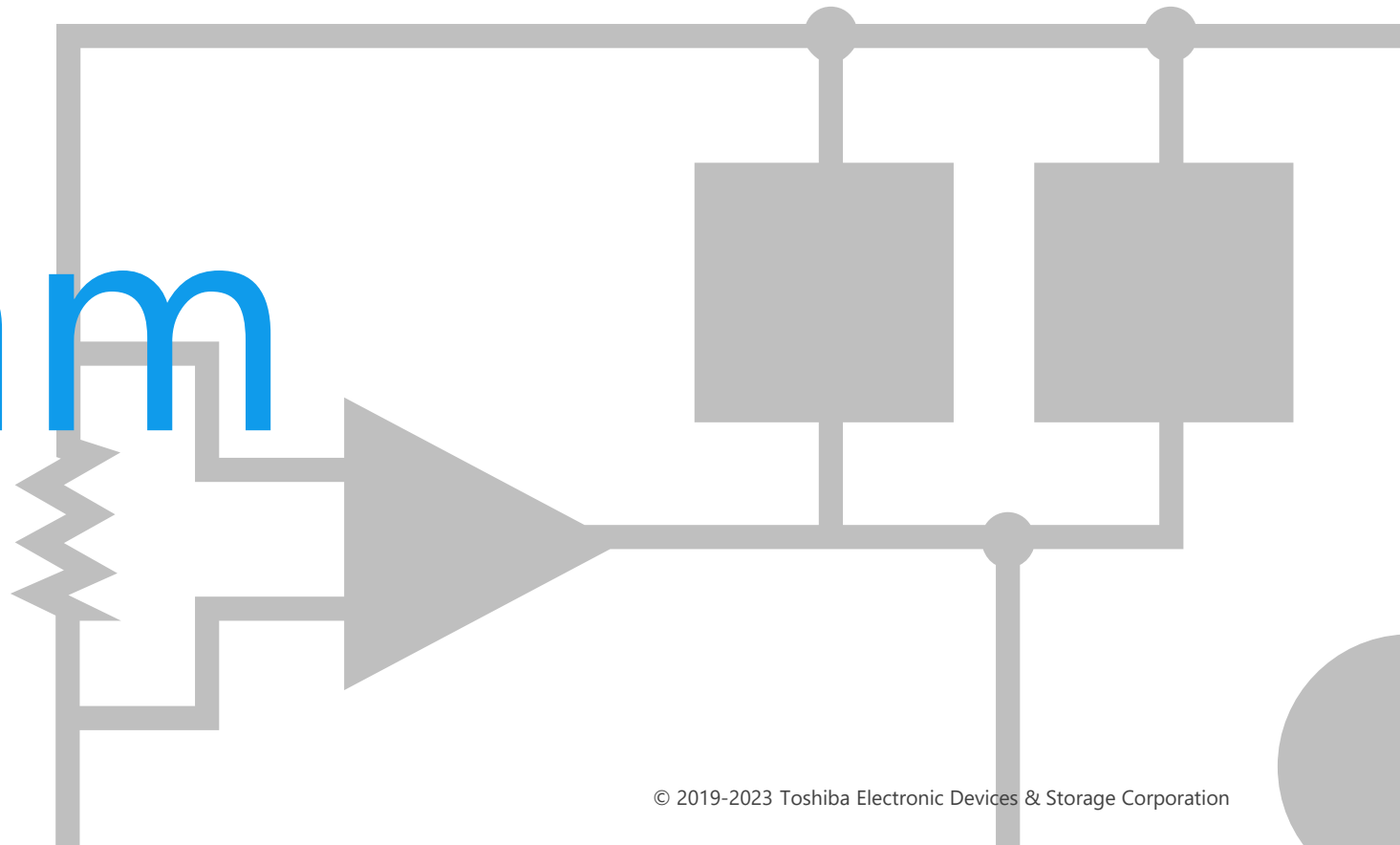

Air Conditioner Overall Block Diagram

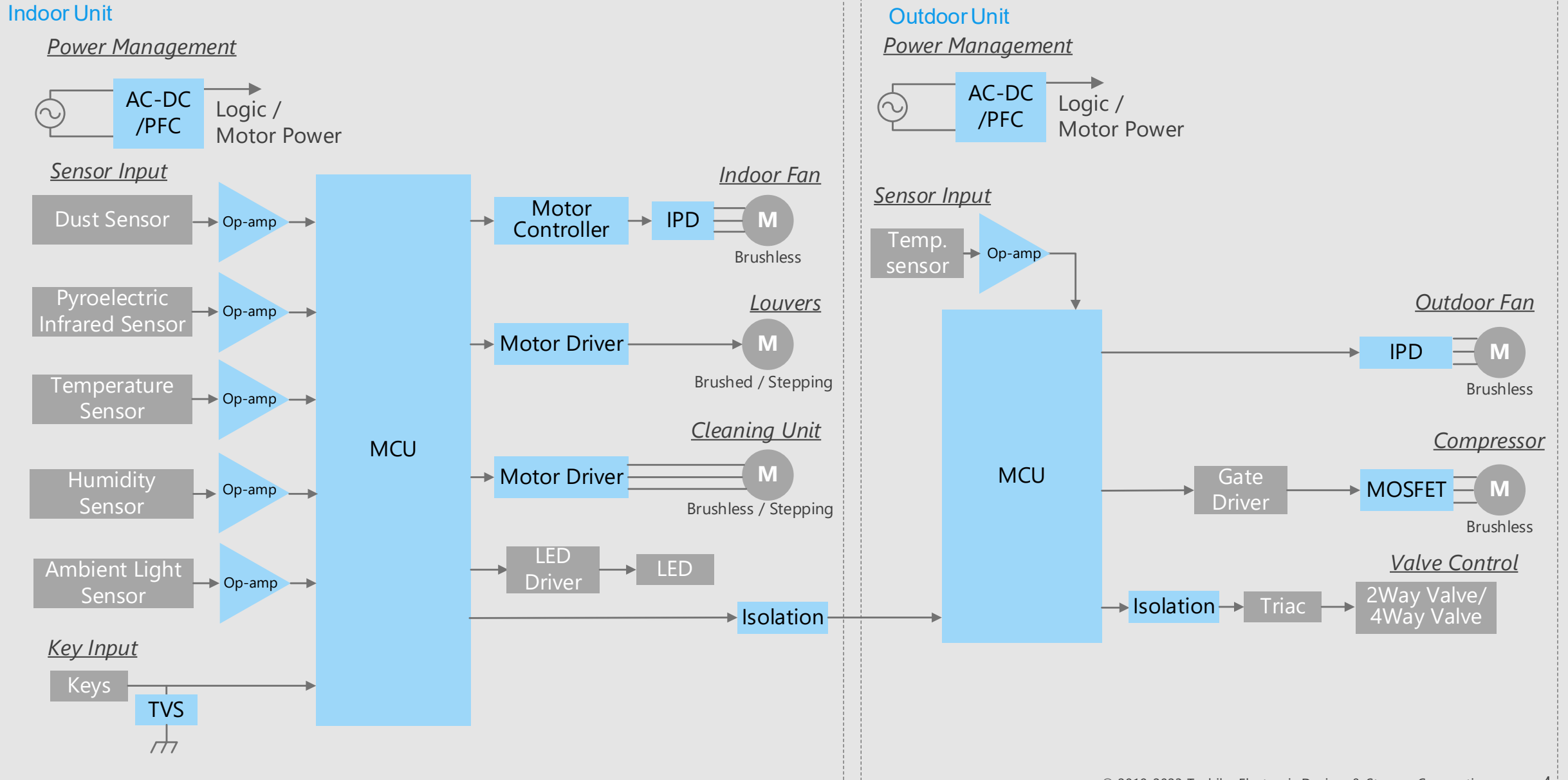

Air Conditioner Details of AC-DC converter unit

AC-DC converter circuit

Outdoor unit

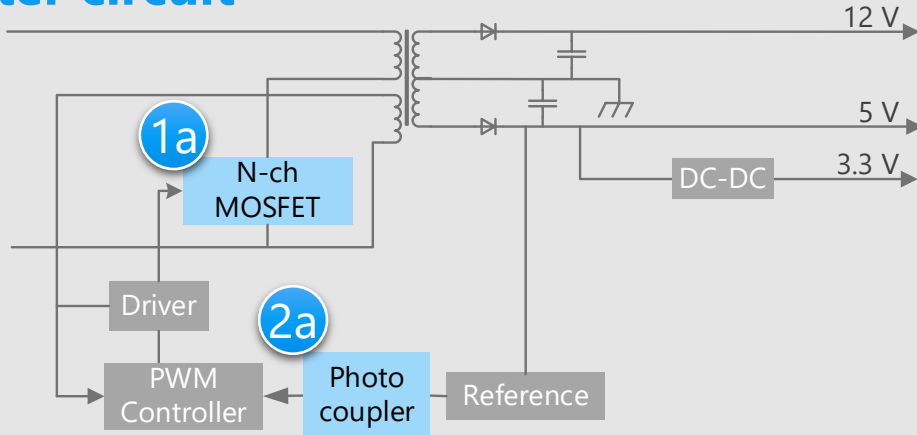

AC-DC converter circuit

Indoor unit

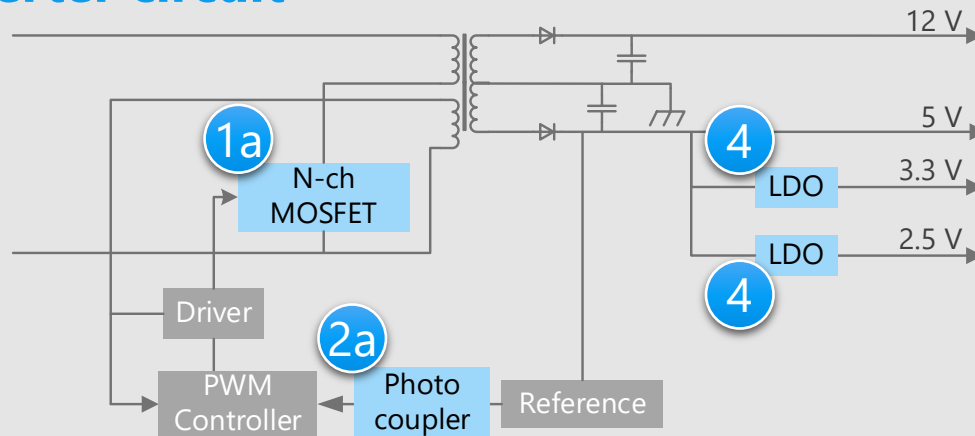

Criteria for device selection

- High voltage MOSFETs are suitable for primary switching of AC-DC converters.
- The transistor output photocoupler is for signal isolation.

Proposals from Toshiba

- **Suitable for high efficiency voltage switching**
 π -MOSVIII Series MOSFET 1a
- **High current transfer ratio and high temperature operation have been achieved**
Transistor output photocoupler 2a
- **Supply the power with low noise**
Small surface mount LDO regulator 4

* [Click on the numbers in the circuit diagram to jump to the detailed descriptions page](#)

Air Conditioner Details of PFC unit

PFC circuit

Active type

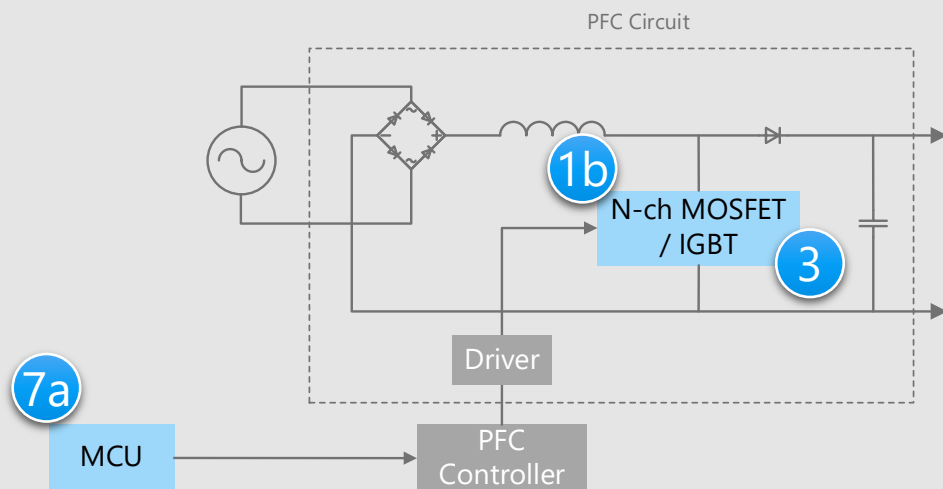

PFC circuit

Partial switching type

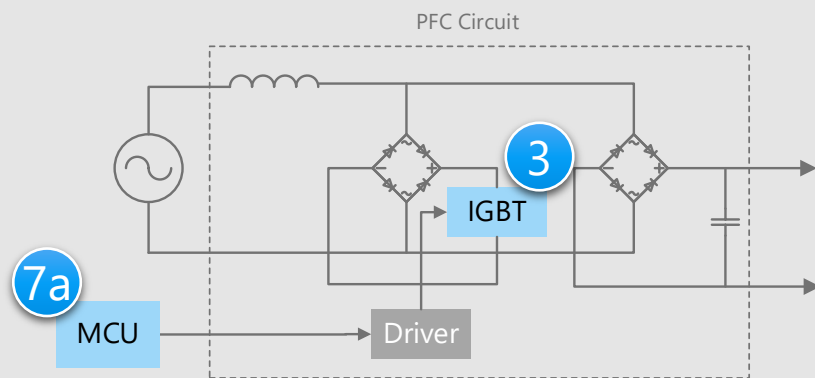

Criteria for device selection

- MOSFETs with high speed switching and low on-resistance are suitable for active type PFC circuit.
- IGBTs with low collector-emitter saturation voltage are suitable for partial switching type PFC circuit.

Proposals from Toshiba

- **Suitable for high efficiency power supply switching**
DTMOSVI Series MOSFET 1b
- **IGBT which is suitable for high voltage and high current system**
Discrete IGBT 3
- **Suitable for PFC and motor control**
MCU M4K Group / M470 Group / M370 Group 7a

* [Click on the numbers in the circuit diagram to jump to the detailed descriptions page](#)

Air Conditioner Details of fan (indoor/outdoor) and compressor unit

Fan section (indoor/outdoor units)

High voltage IPD

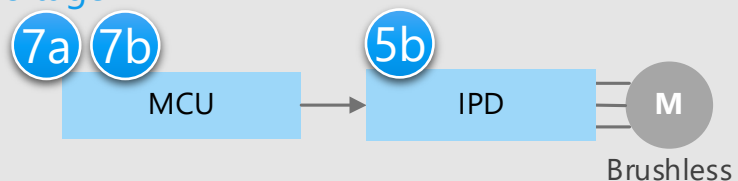

MCD (controller) + high voltage IPD

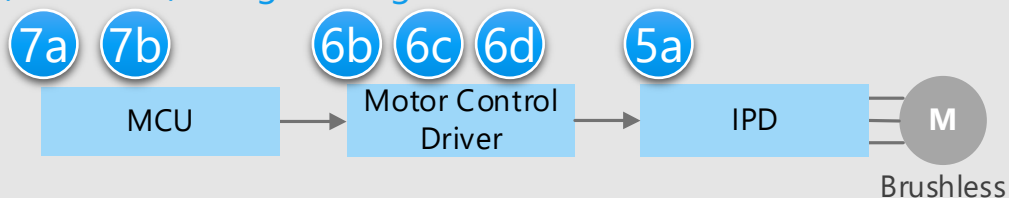

MCU (Three-phase motor controller) + high voltage IPD

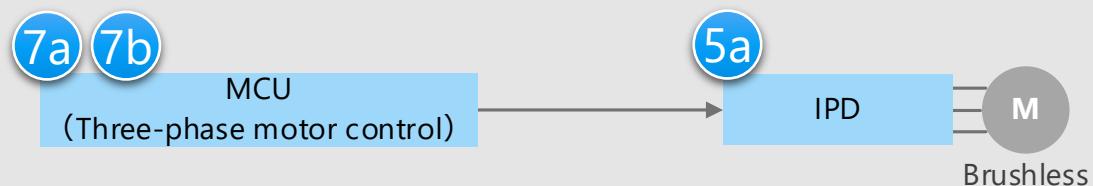

Compressor section

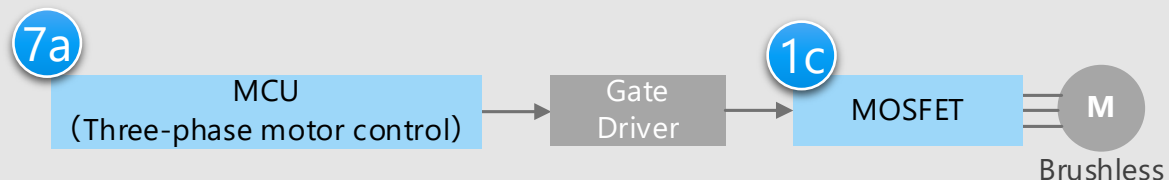

Criteria for device selection

- IPDs are suitable for fan motor drive in indoor and outdoor units.
- MOSFET with short reverse recovery time is suitable for motor drive in compressors.
- By using brushless motor drivers, three-phase brushless DC motors can be controlled easily.

Proposals from Toshiba

- **Suitable for inverter** DTMOSIV(HSD) [Note] Series MOSFET 1c
- **High voltage motor driver circuit** High voltage IPD 5a 5b
- **Easy motor drive** Motor driver 6b 6c 6d
- **Suitable for PFC and motor control** MCU M4K Group / M470 Group / M370 Group 7a
- **Easy software development using general purpose CPU cores** MCU M3H Group 7b

[Note] 4th generation DTMOS with high speed diode

* [Click on the numbers in the circuit diagram to jump to the detailed descriptions page](#)

Air Conditioner Details of cleaning, louver and valve control unit

Cleaning section

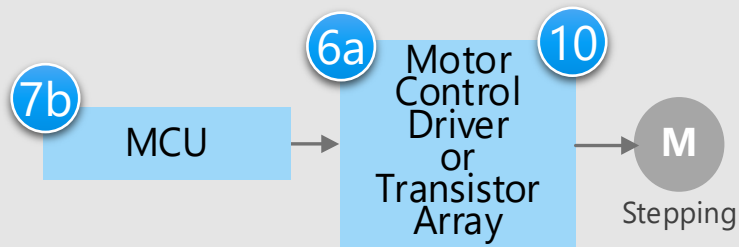

Louver section

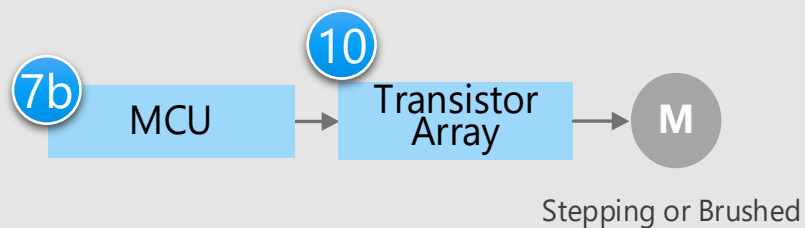

Valve control section

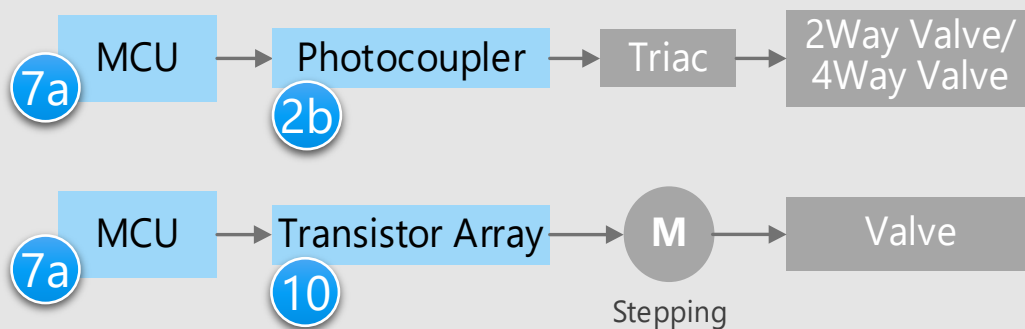

Criteria for device selection

- By using brushless DC motor drivers, three-phase brushless DC motors can be controlled easily.
- Stepping motor driver enables efficient motor control by optimizing real-time current to the motor.
- Brushed DC motor driver allows motor driving with low power consumption.

Proposals from Toshiba

- **Easy motor drive**
Motor driver (6a)
- **Triac driver for high dv/dt**
Triac output photocoupler (2b)
- **Suitable for PFC and motor control**
MCU M4K Group / M470 Group / M370 Group (7a)
- **Easy software development using general purpose CPU cores**
MCU M3H Group (7b)
- **High efficiency and high current driver with built-in low loss DMOS FET**
Transistor array (10)

* [Click on the numbers in the circuit diagram to jump to the detailed descriptions page](#)

Microcontroller section

Power control block for outdoor unit

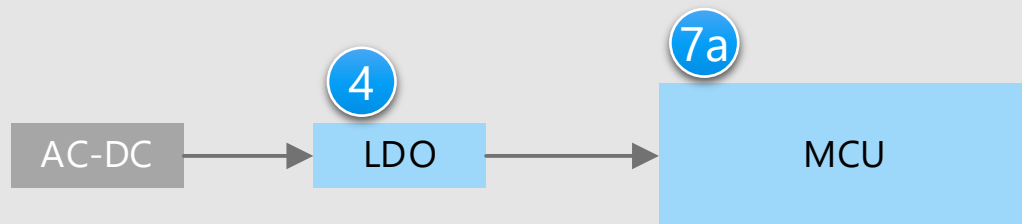

Isolation circuit

Between outdoor and indoor units

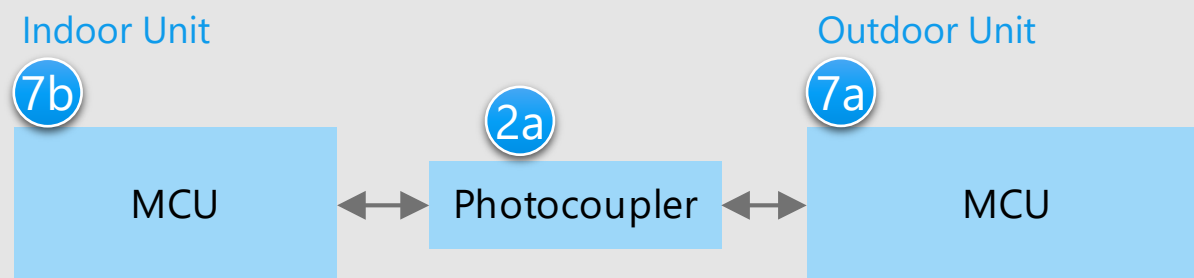

Criteria for device selection

- Isolation devices such as transistor output photocouplers are effective when voltage difference exists between outdoor and indoor GNDs.
- MCUs are suitable for system monitoring and control.

Proposals from Toshiba

- **High current transfer ratio and high temperature operation have been achieved**
Transistor output photocoupler
- **Supply the power with low noise**
Small surface mount LDO regulator
- **Suitable for PFC and motor control**
MCU M4K Group / M470 Group / M370 Group
- **Easy software development using general purpose CPU cores**
MCU M3H Group

2a

4

7a

7b

* [Click on the numbers in the circuit diagram to jump to the detailed descriptions page](#)

Air Conditioner Details of sensor input unit (1)

Dust sensor circuit

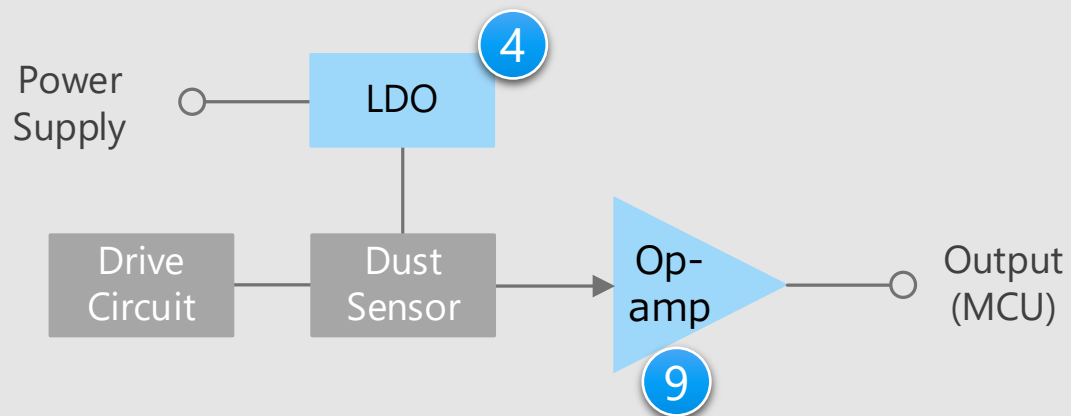

Human sensor circuit

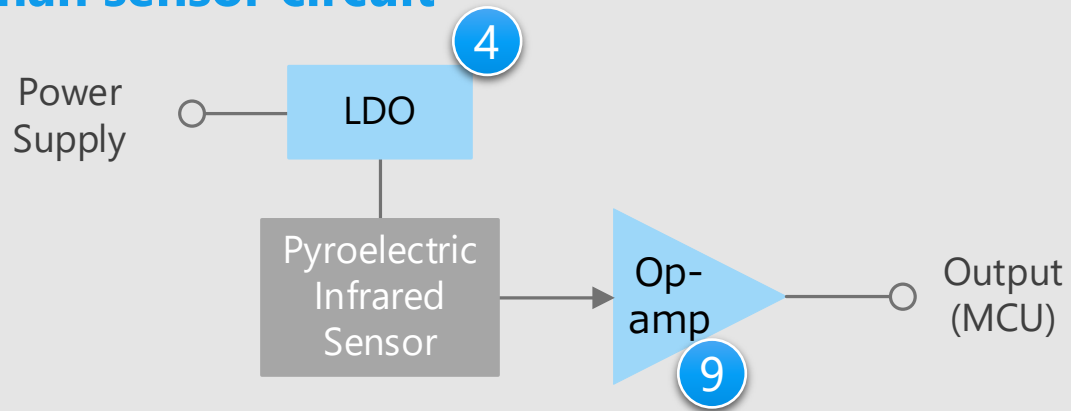

Criteria for device selection

- PSRR (Power Supply Rejection Ratio) of LDO regulator is an important parameter for sensor modules.
- The operational amplifier should be low current consumption or low noise device.
- Small package products contribute to the reduction of circuit board area.

Proposals from Toshiba

- **Supply the power with low noise**
Small surface mount LDO regulator 4
- **Amplification of detected very small signal with low noise**
Low current consumption op-amp / Low noise op-amp 9

* [Click on the numbers in the circuit diagram to jump to the detailed descriptions page](#)

Air Conditioner Details of sensor input unit (2)

Temperature sensor circuit

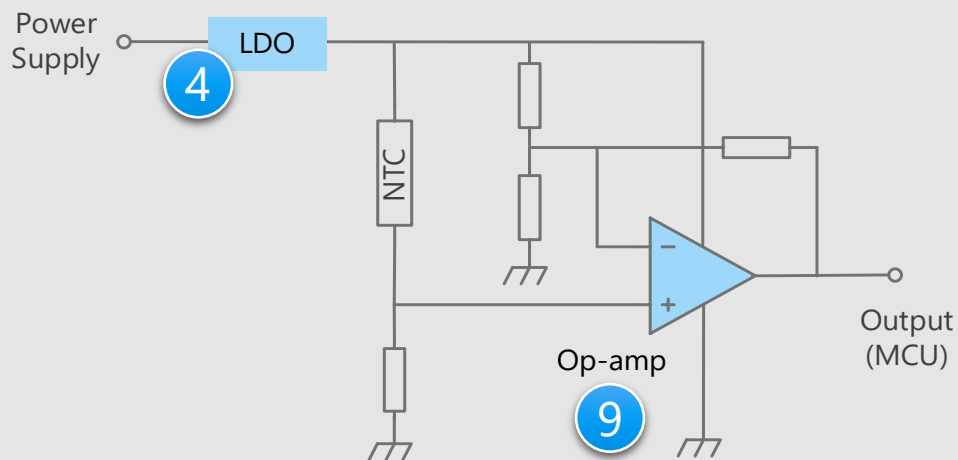

Humidity sensor circuit

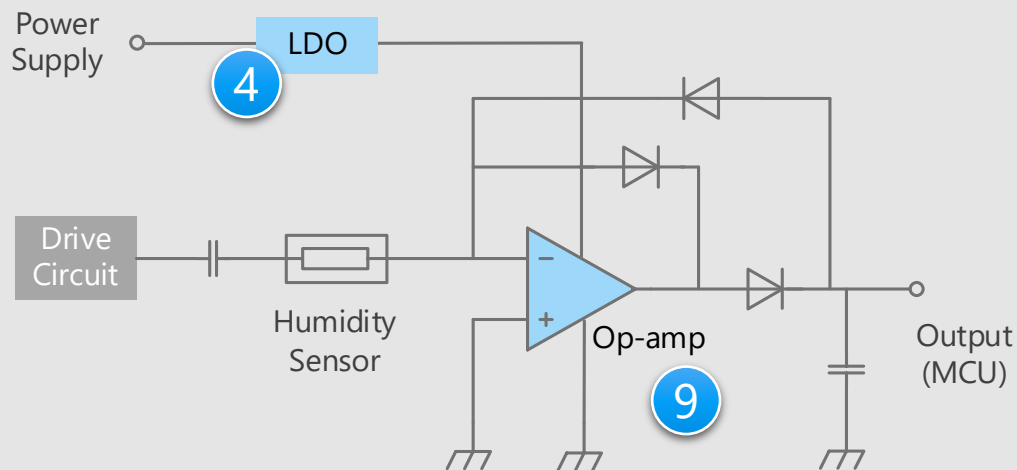

Criteria for device selection

- PSRR (Power Supply Rejection Ratio) of LDO regulator is an important parameter for sensor modules.
- The operational amplifier should be low current consumption or low noise device.
- Small package products contribute to the reduction of circuit board area.

Proposals from Toshiba

- **Supply the power with low noise**
Small surface mount LDO regulator 4
- **Amplification of detected very small signal with low noise**
Low current consumption op-amp / Low noise op-amp 9

* Click on the numbers in the circuit diagram to jump to the detailed descriptions page

Ambient light sensor circuit

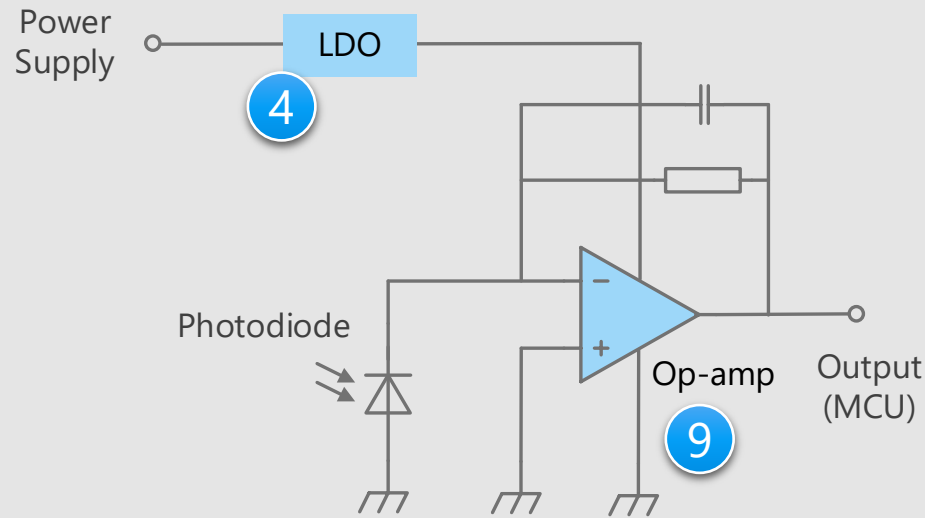

Criteria for device selection

- PSRR (Power Supply Rejection Ratio) of LDO regulator is an important parameter for sensor modules.
- The operational amplifier should be low current consumption or low noise device.
- Small package products contribute to the reduction of circuit board area.

Proposals from Toshiba

- **Supply the power with low noise**
Small surface mount LDO regulator 4
- **Amplification of detected very small signal with low noise**
Low current consumption op-amp
/ Low noise op-amp 9

* [Click on the numbers in the circuit diagram to jump to the detailed descriptions page](#)

Key input circuit

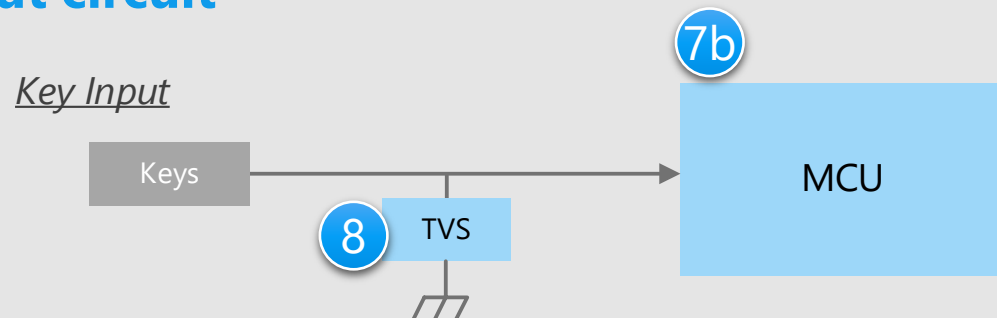

Criteria for device selection

- TVS diodes are suitable for protection from ESD pulses coming in key input unit.
- Small package products contribute to the reduction of circuit board area.

Proposals from Toshiba

- **Easy software development using general purpose CPU cores**
MCU M3H Group 7b
- **Absorb static electricity to prevent malfunction of the circuit**
TVS diode 8

* [Click on the numbers in the circuit diagram to jump to the detailed descriptions page](#)

Recommended Devices

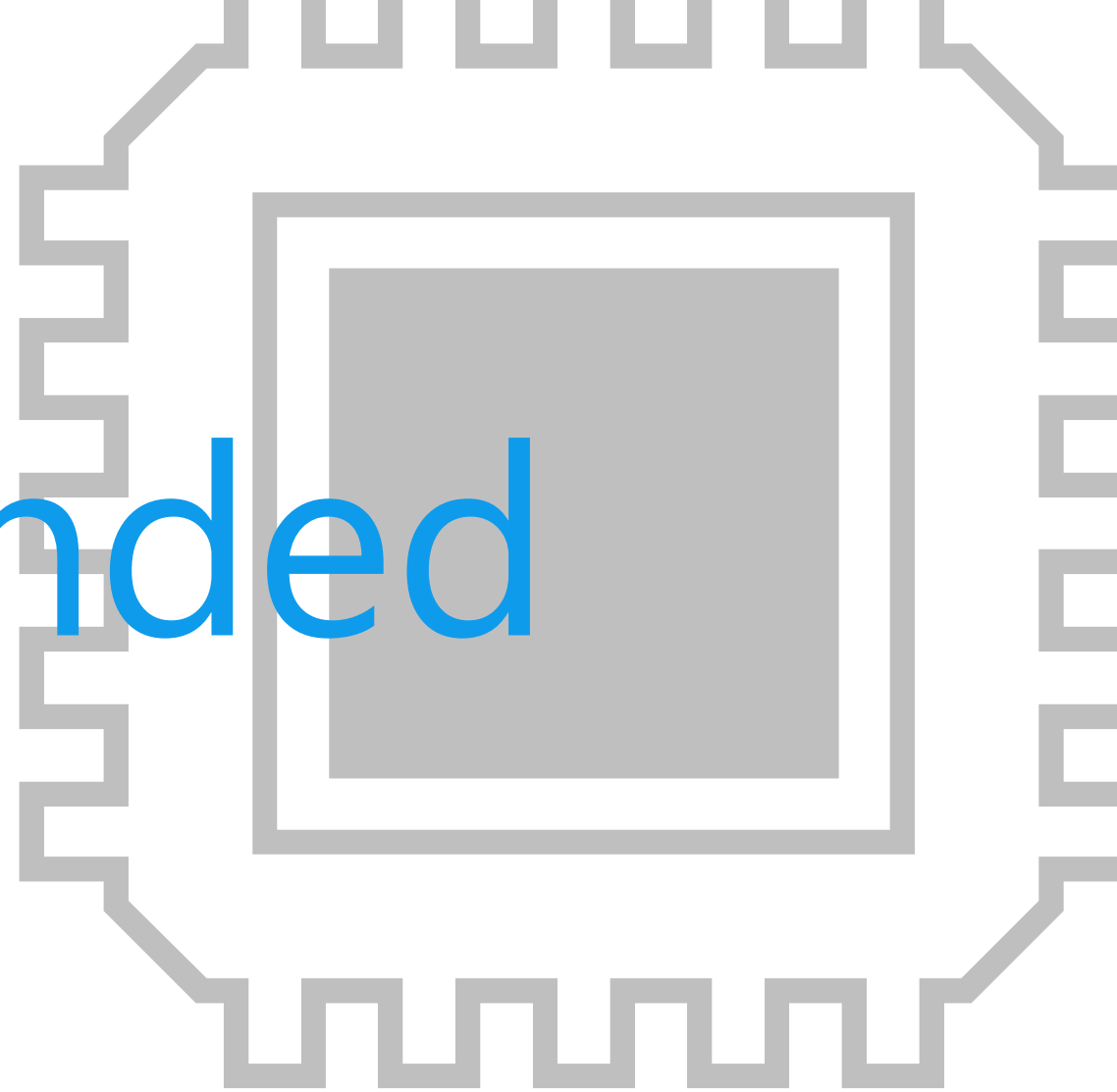

Device solutions to address customer needs

As described above, in the design of air conditioner, “**Quietness/efficiency of motors**”, “**Low power consumption of set**” and “**Miniaturization of circuit boards**” are important factors. Toshiba’s proposals are based on these three solution perspectives.

Quietness/efficiency of motors



Low power consumption
of set



Miniaturization of
circuit boards



Device solutions to address customer needs

	Brushless DC motor drive	High efficiency - low loss	Small size packages
1 π-MOS^{III} / DTMOS^{VI} / DTMOS^{IV}(HSD) Series MOSFET	●	●	●
2 Transistor output photocoupler / Triac output photocoupler		●	●
3 Discrete IGBT	●	●	●
4 Small surface mount LDO regulator		●	●
5 High voltage IPD	●	●	●
6 Motor driver	●	●	●
7 MCU M4K Group / M470 Group / M370 Group / M3H Group	●	●	●
8 TVS diode			●
9 Low current consumption op-amp / Low noise op-amp		●	●
10 Transistor array		●	●

Value provided

Realizes improvement of power supply efficiency by reduction of RonA by 24 % (comparison of Toshiba's conventional products) and contributes miniaturization of set.

1 RonA reduced by 24 %

By using π -MOS^{III} chip design, figure of merit RonA is reduced by 24 % (comparison of Toshiba's π -MOS^{IV} products).

2 Q_g reduced by 23 %

By using π -MOS^{III} chip design, Q_g is reduced by 23 % (comparison of Toshiba's π -MOS^{IV} products).
Reduction of switching loss is expected.

3 C_{oss} reduced by 18 %

By using π -MOS^{III} chip design, C_{oss} is reduced by 18 % (comparison of Toshiba's π -MOS^{IV} products).
Improvement for light load conditions is expected.

Turn-off waveform

Toshiba's conventional product

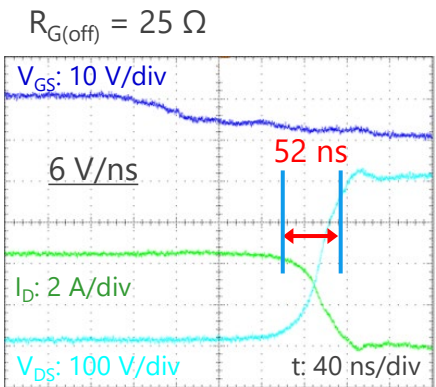

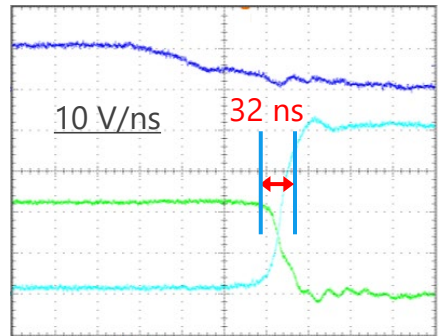

TK9J90E

$R_{G(off)} = 25 \Omega$ [condition]
 $V_{DD} = 400 \text{ V}, I_D = 4.5 \text{ A}, T_c = 25 \text{ }^\circ\text{C}$



(Note) Toshiba internal comparison

Lineup

Part number	TK6A80E	TK10A80E	TK9J90E
Package	TO-220SIS		TO-3P(N) 
V_{DSS} [V]	800	800	900
I_D [A]	6	10	9
$R_{DS(on)}$ [Ω] @ $V_{GS} = 10 \text{ V}$	Typ.	1.35	0.7
	Max	1.7	1
Polarity	N-ch	N-ch	N-ch

[Return to Block Diagram TOP](#)

Value provided

Realizes improvement of power supply efficiency by 40 % reduction of $R_{DS(ON)} \times Q_{gd}$ (comparison of Toshiba's conventional products).

1 $R_{DS(ON)} \times Q_{gd}$ reduced by 40 %

Using a single epitaxial process, the figure of merit $R_{DS(ON)} \times Q_{gd}$ was reduced by 40 % by optimizing the structure (comparison of Toshiba's DTMOSIV-H 600 V products). By realizing low $R_{DS(ON)} \times Q_{gd}$, device switching loss was reduced contributing to improvement in power supply efficiency of equipment.

2 RonA reduced by 18 %

The figure of merit RonA of the latest generation [Note1] DTMOSVI has been reduced by 18 % compared with the previous generation (Toshiba's DTMOSIV 650 V products). Achieving low on-resistance while maintaining high voltage contributes to high efficiency of equipment.

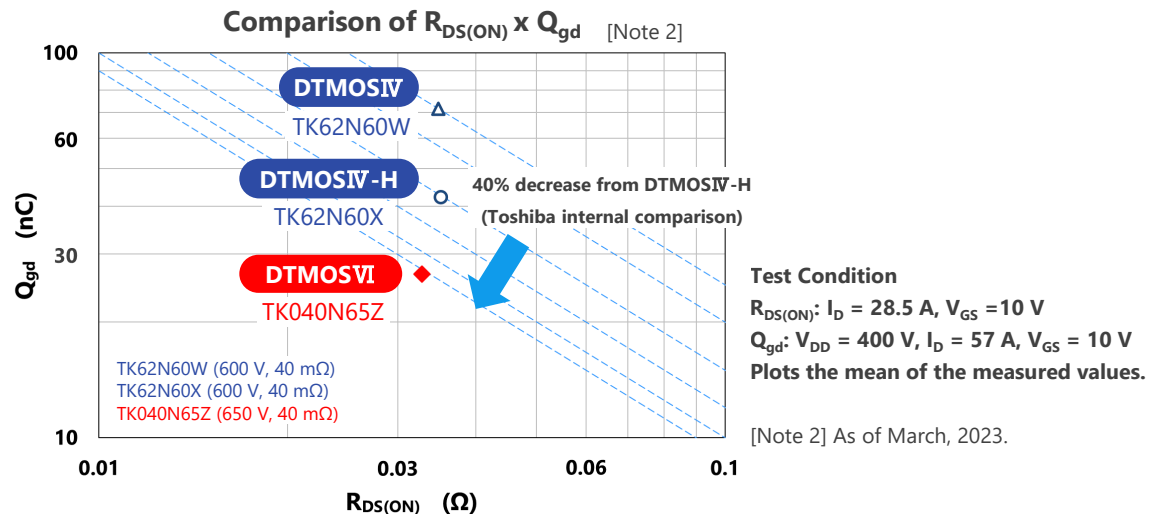

[Note1] As of March 2023

Lineup			TK065U65Z	TK040N65Z
Part number			TK065U65Z	TK040N65Z
Package			TOLL	TO-247
V_{DSS} [V]			650	650
I_D [A]			38	57
$R_{DS(ON)}$ [Ω] @ $V_{GS} = 10 \text{ V}$	Typ.		0.051	0.033
	Max		0.065	0.040
Polarity			N-ch	N-ch

[Return to Block Diagram TOP](#)

Value provided

The figure of merit R_{onA} has been reduced by 30 % (compared with Toshiba conventional products), then contribute to improve efficiency of power supply.

1 RonA 30 % reduction

Adoption of newly developed single epitaxial process to reduce the figure of merit R_{onA} by 30 %.
(Compared with Toshiba DTMOSIII products)

2 Reduction of on-resistance increase at high temperature

The single epitaxial process reduces the on-resistance increase at high temperature.

3 Optimization of switching speed

Optimization of switching speed has been achieved by reduction of C_{OSS} (by 12 %, compared with Toshiba conventional products) and other factors.

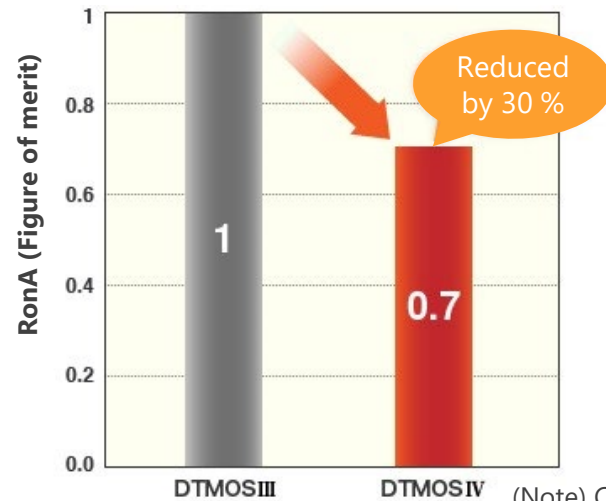

Lineup

Part number	TK20A60W5	
Package	TO-220SIS	
V_{DSS} [V]	600	
I_D [A]	20	
$R_{DS(ON)}$ [Ω] @ $V_{GS} = 10$ V	Typ.	0.15
	Max	0.175
Polarity	N-ch	

[◆Return to Block Diagram TOP](#)

Value provided

High CTR (Current Transfer Ratio) is realized even in low input current range ($I_F = 0.5 \text{ mA}$).

1 High current transfer ratio

The TLP383 and TLP293 is a high isolation photocoupler that optically couples a phototransistor and high output infrared LED. Compared to Toshiba's conventional products (TLP385), higher CTR (Current Transfer Ratio) in low input current range (@ $I_F = 0.5 \text{ mA}$) is realized.

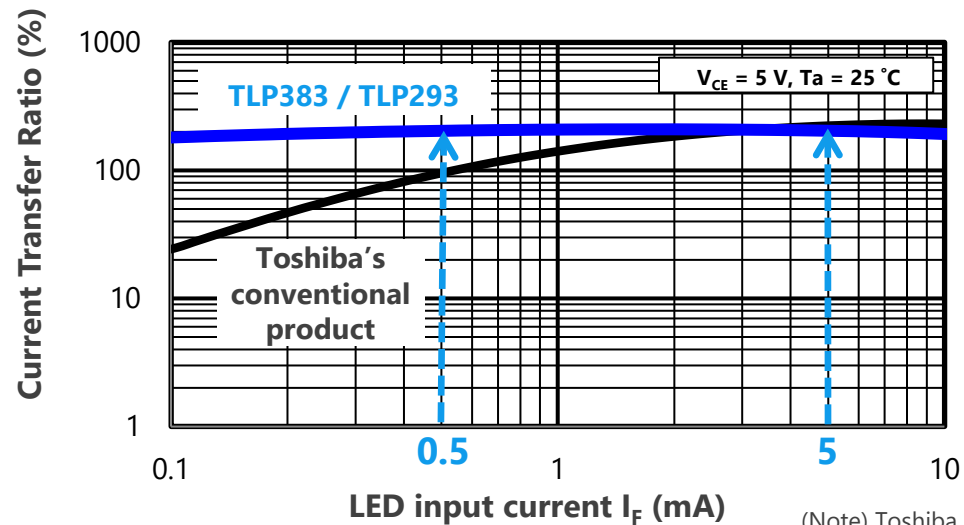

(Note) Toshiba internal comparison

2 High temperature operation

The TLP383 and TLP293 are designed to operate even under severe ambient temperature conditions.

Lineup

Part number	TLP383	TLP293	TLP385
Package	4pin SO6L 	SO4 	4pin SO6L 
BV_S [Vrms]	5000	3750	5000
T_{opr} [$^\circ\text{C}$]	-55 to 125	-55 to 125	-55 to 110

[◆Return to Block Diagram TOP](#)

Value provided

Using a triac with high dv/dt pre-driver for solenoid valve control suppresses false turn-on.

1 Low input and zero crossing input control

This device optically couples a photo triac and a high power infrared LED, providing high isolation equivalent to an electromagnetic relay. Capable of low input operation, the photo coupler can be directly controlled by a microcontroller.

■ Example of AC switch using triac output photocoupler

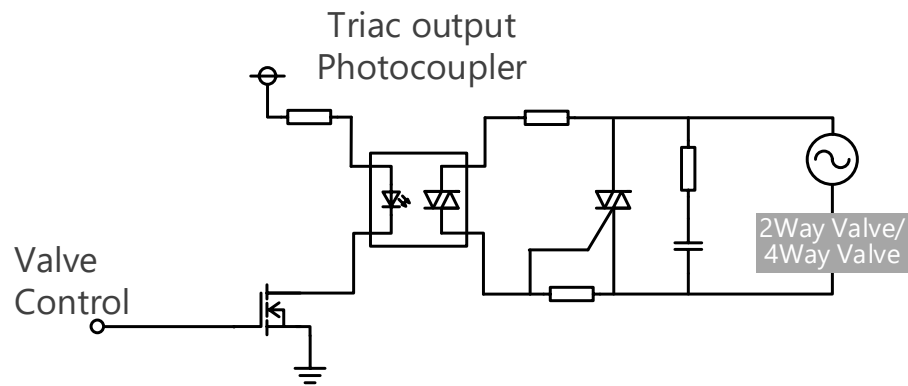

2 High dv/dt

The TLP3083 is a triac having a high dv/dt of 2000 V/μs (Typ.). With a high OFF-state voltage of 800 V, it can work with various AC power supplies.

Lineup		
Part number	TLP3083	TLP3073
Package	5pin DIP6 	
Output type	Zero crossing functionary (ZC)	Non zero crossing functionary (NZC)
BV _S [Vrms]	5000	
T _{opr} [°C]	-40 to 100	

[◆Return to Block Diagram TOP](#)

Value provided

Switching devices for high voltage (600 V or more) and high current (30 A or more) application. Lineup of low $V_{CE(sat)}$ products are effective in reducing conduction loss.

1 High speed, low saturation voltage

By adopting a thin wafer punch-through structure, high speed turn-off characteristics and low $V_{CE(sat)}$ characteristics are realized.

2 High breakdown tolerance

Toshiba has a lineup of products with high breakdown tolerance (short circuit withstand time t_{sc} and reverse bias safe operating area RBSOA).

3 Enhancement type

Since collector current does not flow when gate voltage is not applied for enhancement devices, handling is easy.

■ Active type PFC circuit example using discrete IGBT (GT50JR22)

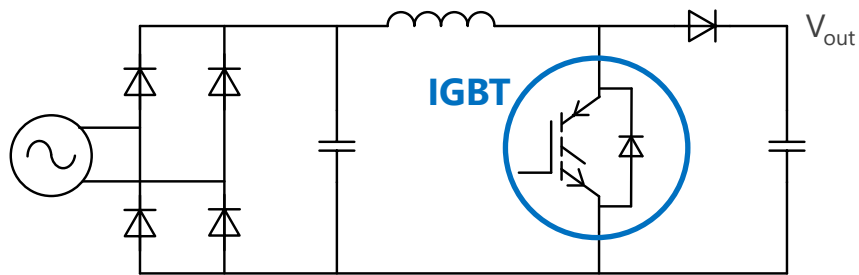
 $f_{sw} = 20 \text{ to } 35 \text{ kHz}$

Lineup

Part number	GT50JR22	GT30J122A	GT50J123	GT30J65MRB	
Package	TO-3P(N) 				
Built-in FWD	✓ (RC structure)	-	-	✓ (RC structure)	
V_{CES} [V]	600	600	600	650	
I_C [A]	50	30	59	60	
$V_{CE(sat)}$ [V] @ $I_C = 50 \text{ A}$, $V_{GE} = 15 \text{ V}$, $T_a = 25^\circ\text{C}$	Typ.	1.55	1.7	1.90	1.40 @ $I_C = 30 \text{ A}$
	Max	2.20	2.8	2.50	1.80 @ $I_C = 30 \text{ A}$
Breakdown tolerance	t_{sc} [μs]	-	-	5	-
	RBSOA	-	-	120 A, 600 V (full square)	-

[◆Return to Block Diagram TOP](#)

Value provided

Wide lineup from general purpose type to small package type are provided.
Contribute to realize a stable power supply not affected by fluctuation of battery.

1 Low dropout voltage

The originally developed latest process significantly improved the dropout voltage characteristics.

2 High PSRR Low output noise voltage

Many product series that realize both high PSRR (Power Supply Rejection Ratio) and low output noise voltage characteristics are provided. They are suitable for stable power supply for analog circuit.

3 Low current consumption

0.34 μA of $I_{B(ON)}$ is realized by utilizing CMOS process and unique circuit technology.
(TCR3U Series)

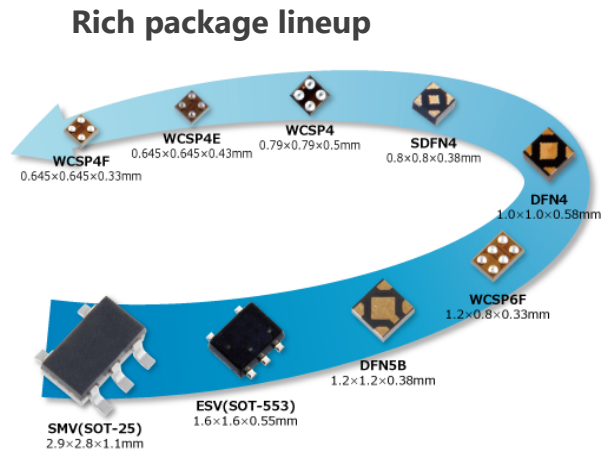
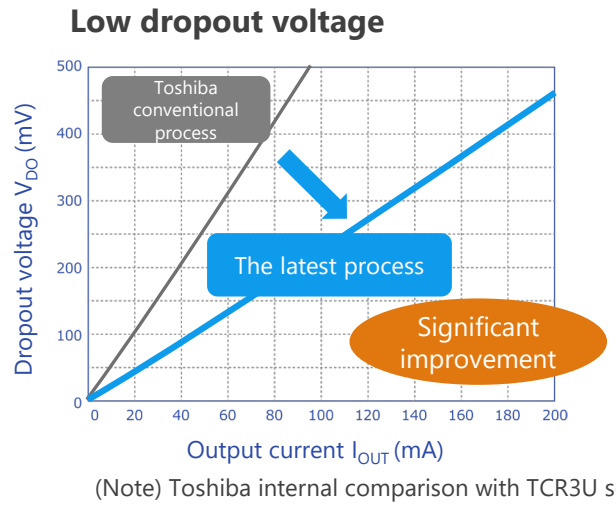

Lineup

Part number	TCR15AG Series	TCR13AG Series	TCR8BM Series	TCR5BM Series	TCR5RG Series	TCR3RM Series	TCR3U Series	TCR2L Series	TAR5 Series
Features	Low dropout voltage High PSRR				High PSRR Low noise Low current consumption		Low current consumption		15 V Input voltage Bipolar type
I_{OUT} (Max) [A]	1.5	1.3	0.8	0.5		0.3		0.2	
PSRR (Typ.) [dB] @f = 1 kHz	95	90	98	98	100	100	70	-	70
I_B (Typ.) [μA]	25	56	20	19	7	7	0.34	1	170

[Return to Block Diagram TOP](#)

Value provided

It is a brushless DC motor driver with built-in MOSFETs or IGBTs and can be driven at a variable speed by control signals from the MCU.

1 Built-in circuit required to drive the motor

It contains a level shifting high side driver, low side driver and MOSFETs or IGBTs.
 TPD4204F: MOSFET output
 TPD4163F/TPD4163K/TPD4164F/TPD4164K: IGBT output

2 Motor drive terminals and control terminals are separated

High voltage and large current terminals and the control terminals are separated on both sides of the package, thereby eliminating the complexity of wiring.



3 Various protection functions

Over current and under voltage protection, shutdown and thermal shutdown functions are available.

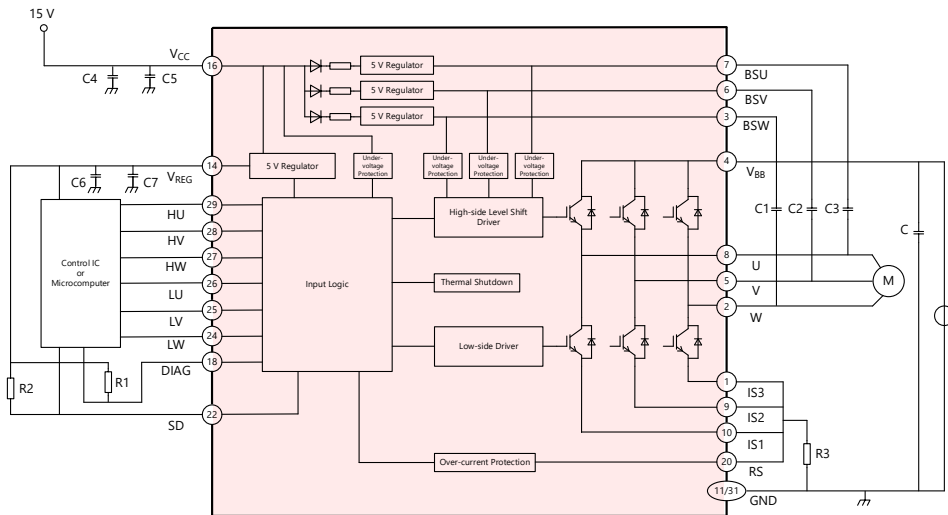
TPD4163F Application Circuit Example

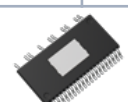

Lineup

Part number	TPD4204F	TPD4163F	TPD4164F	TPD4163K	TPD4164K
Package	 P-SSOP30-1120-1.00-001	 P-HSSOP31-0918-0.80-002		 P-HDIP30-1233-1.78-001	
V _{BB} [V]	600				
I _{out} [A]	2.5	1.0	2.0	1.0	2.0
V _{CC} [V]	13.5 to 16.5				

[Return to Block Diagram TOP](#)

Value provided

This product optimizes for brushless DC motor driving and has the functions required for motor driving into one package.

1 Contributing to low power consumption

The power consumption can be reduced by replacing from the AC motor to a brushless DC motor.

2 Contributing to reducing the number of parts

Built-in functions and protection functions required for inverter operation can reduce the number of parts.

3 Contributing to reduction of circuit board area

The use of small surface mount packages contributes to the reduction of circuit board area.

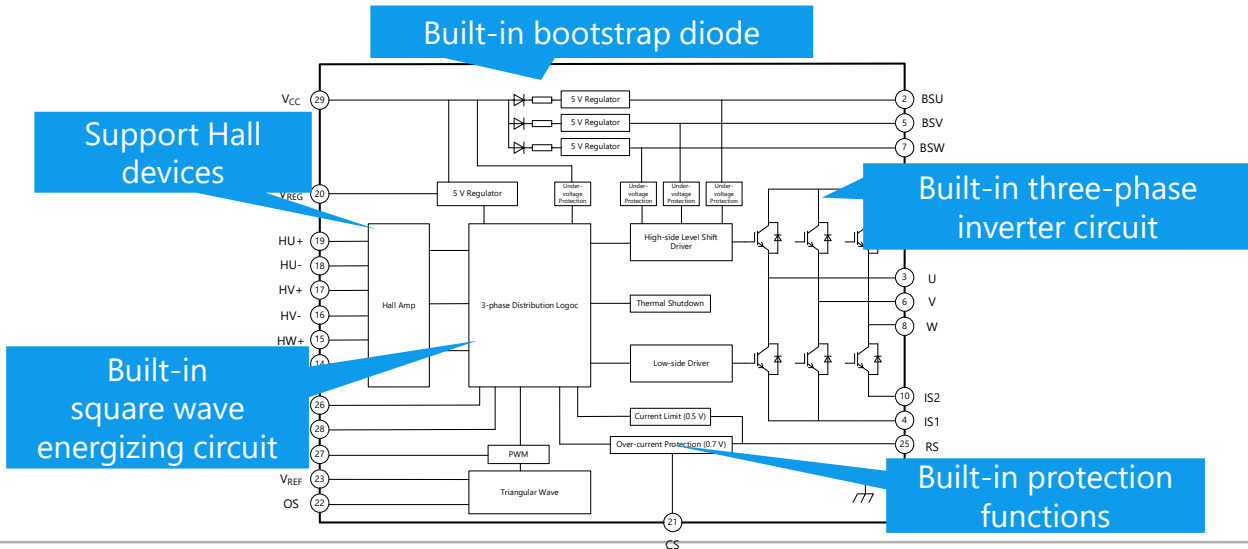

Lineup

Part number	TPD4162F	
Package	P-HSSOP31-0918-0.80-002	
V_{BB} [V]	600	
I_{out} [A]	0.7	
V_{CC} (Max) [V]	17.5	
Protective function	Current limitation, overcurrent protection, thermal shutdown, under voltage protection	

[Return to Block Diagram TOP](#)

Value provided

Support low voltage motor drive (2.5 V (Min)) and contributes to the power saving of set.

1 Low voltage operation

Motor power supply voltage is 2.5 V (Min) for low voltage applications such as battery operation devices.

2 Low current consumption

Standby current is 2 μ A or less (IC total) for power saving of devices.

3 Error detection functions

Over current detection (ISD), thermal shutdown (TSD) and under voltage lockout (UVLO) are available.

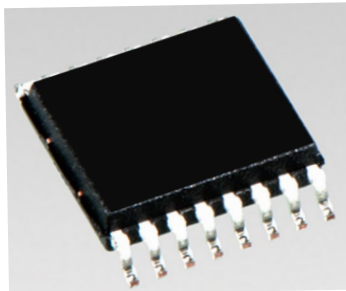

P-TSSOP16-0505-0.65-001 Package
(5.0 x 6.4 x 1.2 mm)

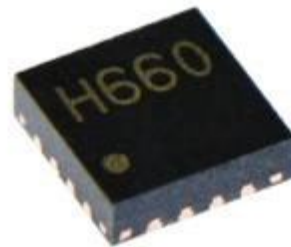

P-VQFN16-0303-0.50-001 Package
(3.0 x 3.0 x 0.9 mm)

Lineup

Part number	TC78H621FNG	TC78H660FNG	TC78H660FTG
V_M [V]	18	18	18
I_{OUT} [A]	1.1	2.0	2.0
R_{on} (upper and lower sum) (Typ.) [Ω]	0.8	0.48	0.48
Control interface	PHASE input	IN/PHASE inputs	IN/PHASE inputs
Step	2phase/1-2phase excitation	2phase/1-2phase excitation	2phase/1-2phase excitation
Motor power supply voltage	2.5 V (Min)	2.5 V (Min) RS resistor less	2.5 V (Min) RS resistor less
Error detection function	ISD, TSD, UVLO	ISD, TSD, UVLO	ISD, TSD, UVLO
Package	P-TSSOP16-0505-0.65-001	P-TSSOP16-0505-0.65-001	P-VQFN16-0303-0.50-001

[◆Return to Block Diagram TOP](#)

Value provided

Toshiba's proprietary technology eliminates the need for phase adjustment and achieves high efficiency for a wide range of rotation speeds.

1 High efficiency in a wide range of rotation speeds

Toshiba's automatic lead angle control technology realizes a high efficiency drive regardless of motor speed, load torque or power supply voltage.

2 Motor control with low noise and low vibration

Sine wave drive system with smooth current waveforms contributes to lower motor noise and vibration compared to conventional square wave drive system ^[Note].

3 Small package

VQFN32 package is adopted for TC78B042FTG, which requires small space. SSOP30 package is adopted for TC78B041FNG as conventional type.

[Note] Comparison with Toshiba products



SSOP30-P-300-0.65 Package
(10.2 x 7.6 x 1.6 mm)



P-VQFN32-0505-0.50-005 Package
(5 x 5 x 1 mm)

Lineup

Part number	TC78B041FNG	TC78B042FTG
Power supply voltage	6 to 16.5 V (operating range)	
Drive type	Sine wave drive	
Features	Auto lead angle control for optimizing voltage and current phases	
	Hall element or hall IC input	
	Forward/reverse rotation switch	
	Motor lock detection	
	Selectable pulse number of rotation pulse signal output	
	Built-in 5 V regulator (VREF pin)	Built-in 5 V regulators (VREF/VREF2 pin)
	Error detection positive input	Error detection positive/negative input
Package	SSOP30-P-300-0.65	P-VQFN32-0505-0.50-005

[◆Return to Block Diagram TOP](#)

Value provided

High voltage and high current brushless DC motor driving can be implemented by external IPD.

1 High efficient motor control by automatic phase control

Automatic phase controller by current feedback is integrated adding conventional fixed phase voltage input (32 steps).

2 Motor control with low noise and low vibration

Sine wave drive system with smooth current waveforms contributes to lower motor noise and vibration compared to conventional square wave drive system ^[Note].

3 Sufficient development support

Various supports such as third party evaluation board and PSpice[®] data for development and design are prepared.

[Note] Comparison with Toshiba products

TB6584FNG, TB6584AFNG
TB6634FNG

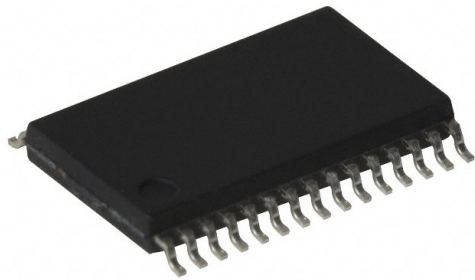

SSOP30-P-300-0.65 Package (10.2 x 7.6 x 1.6 mm)

Lineup

Part number	TB6584FNG	TB6584AFNG	TB6634FNG
Supply voltage	6 to 16.5 V (operating range)		
Output current	0.002 A (for MOSFET driver)		
Drive mode	Sine wave drive		
Features	Lead angle control: Auto phase control (current feedback) Sensor input: Hall device/Hall IC compatible Internal regulator: 5 V, 30 mA (Max) Error detection: overcurrent protection, abnormal position signal protection, undervoltage lockout, motor restrained detection (TB6634FNG)		

[◆Return to Block Diagram TOP](#)

Value provided

A motor control IC and IGBTs are integrated into one package, contributing to the miniaturization of circuit boards.

1 A motor control IC and IGBTs

A motor control IC with sine wave PWM drive function and IGBTs with 600 V and 2 A characteristics are integrated into one package.

2 Motor control with low noise and low vibration

Sine wave drive system with smooth current waveforms contributes to lower motor noise and vibration compared to conventional square wave drive system ^[Note].

3 High heat dissipation

HDIP30 package is adopted for TB67B000AHG, which has high heat dissipation. HSSOP34 package is adopted for TB67B000AFG, which is smaller than HDIP30.

[Note] Comparison with Toshiba products



P-HDIP30-1233-1.78-001
(32.8 x 13.5 x 3.525 mm)



P-HSSOP34-0918-0.80-001
(17.5 x 11.93 x 2.2 mm)

Lineup

Part number	TB67B000AHG	TB67B000AFG
Operating voltage range	Power supply for control: 13.5 to 16.5 V	
	Power supply for motor drive: 50 to 450 V	
Output current	2 A	
Drive type	Sine wave PWM drive / Wide angle commutation	
Lead angle control	0 to 58 degrees 32 steps / 0 to 28 degrees 16 steps	
Speed command input voltage	Motor operation: 2.1 to 5.4 V	
Features	IGBT three-phase bridge, oscillator circuit, built-in bootstrap diode, overcurrent protection, thermal shutdown, undervoltage lockout, motor lock detection	
Package	P-HDIP30-1233-1.78-001	P-HSSOP34-0918-0.80-001

[◆Return to Block Diagram TOP](#)

Value provided

System cost reduction, higher efficiency and less development work.

1 Equipped with motor control co-processor

Toshiba's original co-processor vector engine (VE) for motor control reduces CPU load and allows control of multiple motors and peripherals.

2 Equipped with motor control circuit

A variety of three-phase PWM [Note 1] waveforms and AD converters enable highly efficient, low noise control. The Advanced Encoder (A-ENC) reduces the load of CPU process in detecting the position performed for each PWM.

3 Provide development support tools

Third party evaluation boards and sample programs that can be used to shorten the development time are provided. Toshiba has begun offering a new, simple, versatile motor control software development kit (MCU Motor Studio). [Note 2]

[Note 1] Pulse Width Modulation

[Note 2] For M4K Group and will gradually expand for TXZ+™ Series products

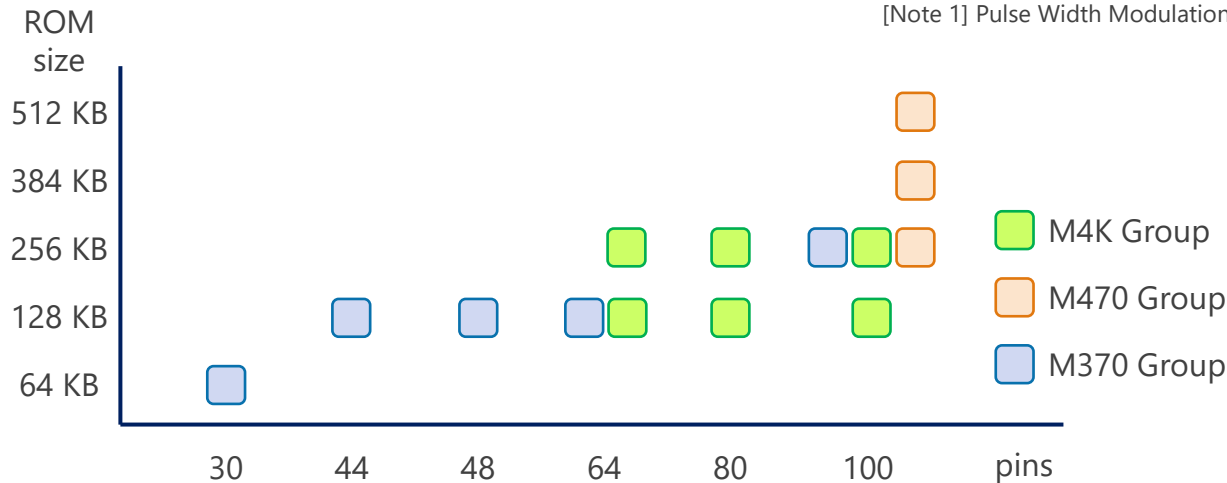

Lineup		
Series	Group	Function
TXZ+™4A Series	M4K Group	Arm® Cortex®-M4, 160 MHz operation 4.5 to 5.5 V, three motor control (Max), Data Flash
TX04 Series	M470 Group	Arm® Cortex®-M4, 120 MHz operation 4.5 to 5.5 V, two motor control (Max)
TX03 Series	M370 Group	Arm® Cortex®-M3, 80 MHz operation 4.5 to 5.5 V, two motor control (Max)

[Return to Block Diagram TOP](#)

Value provided

MCU is equipped with many peripheral functions. MCU contributes to higher functionality as a system control MCU.

1 Built-in Arm® Cortex®-M3 CPU core

MCU is equipped with Arm Cortex-M3 core. Maximum operation frequency is 120 MHz.

2 Various lineup of built-in memories and packages

M3H group integrates both 512 KB (Max) code and 32 KB data flash memories which support 100,000 write cycle endurance, and has a wide lineup of package from 64 to 144 pins.

3 Equipped with many peripheral functions

M3H Group have many peripheral functions such as UART, SPI, I²C, 12bit AD converter, 8bit DA converter, three-phase PWM [Note1] output, ENC and digital LCD driver [Note2], etc.

[Note 1] Pulse Width Modulation

[Note2] 64 pin products aren't equipped with digital LCD driver.

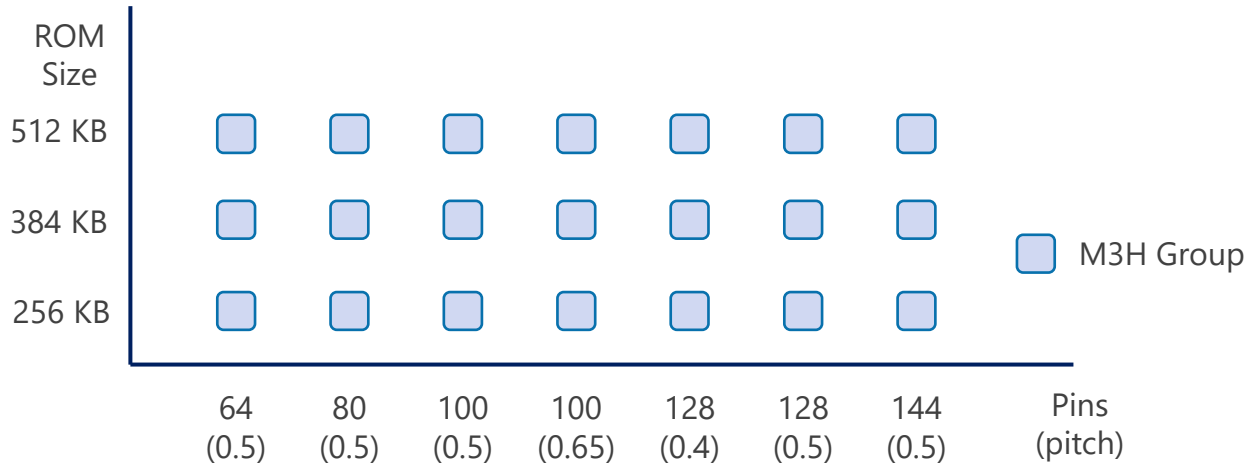

Lineup		
Series	Group	Function
TXZ+™M3A Series	M3H Group	Arm® Cortex®-M3, 120 MHz, 2.7 to 5.5 V operation

[Return to Block Diagram TOP](#)

Value provided

Absorbs static electricity from external terminals, prevents circuit malfunction and protects devices.

1 High ESD pulse absorption performance

Improved ESD absorption compared to Toshiba's conventional products. (50 % reduction in operating resistance) For some products, both low operating resistance and low capacitance are realized and ensures high signal protection performance and signal quality.

2 Suppress ESD energy by low clamp voltage

Protect the connected circuits and devices using Toshiba own technology.

3 Suitable for high density mounting

A variety of small packages are available.

ESD Pulse Absorption Performance (Toshiba internal comparison)

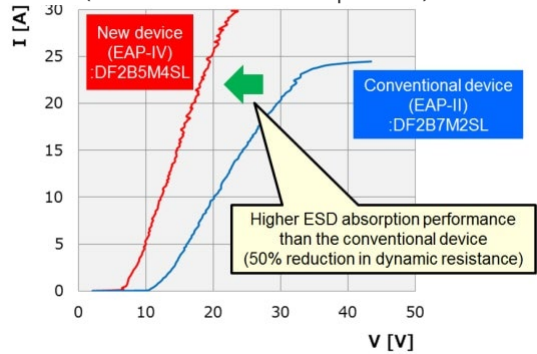

Unidirectional

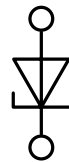



Suitable for paths such as logic signals. There are lineups of 1in1, 2in1, 4in1, 5in1, 7in1.

Bidirectional



Suitable for paths with both polar signals such as audio signals

Lineup

Part number	DF2B7BSL	DF2B5M4SL	DF2B6M4SL
Package	SL2 	SL2 	SL2 
V_{ESD} [kV]	±30	±20	±20
V_{RWM} (Max) [V]	5.5	3.6	5.5
C_t (Typ.) [pF]	12	0.2	0.2
R_{DYN} (Typ.) [Ω]	0.2	0.5	0.5

(Note) This product is an ESD protection diode and cannot be used for purposes other than ESD protection.

[Return to Block Diagram TOP](#)

Value provided

Lineup includes low current consumption type that contributes to low power consumption and a low noise type that maximizes the performance of high performance sensors.

1 Low voltage operation

We have a lineup of low power supply voltage-driven operational amplifiers using CMOS process for low power supply voltage-driven wearable equipment.

2 Low current consumption (TC75S102F) $I_{DD} = 0.27$ [μA] (Typ.)

CMOS processes have been used to achieve lower current consumption. This contributes to lower power consumption and longer life of wearable equipment.

3 Low noise (TC75S67TU) $V_{NI} = 6.0$ [$\text{nV}/\sqrt{\text{Hz}}$] (Typ.) @ $f = 1$ kHz

This CMOS operational amplifier can amplify minute signals detected by various sensors [Note] with low noises. By optimizing the process, the equivalent input noise voltage has been reduced.

[Note] Sensor types: vibration, shock, acceleration, pressure, infrared, temperature, etc.

TC75S102F

Current Consumption Characteristic
(Toshiba internal comparison)

Low current consumption product TC75S102F

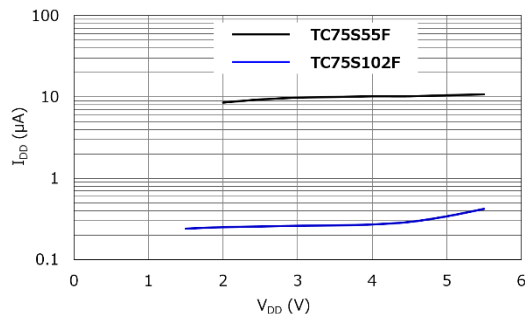

TC75S67TU



Noise Characteristic
(Toshiba internal comparison)

Reduce 1/f noise (10 Hz) by 86 % from our normal products

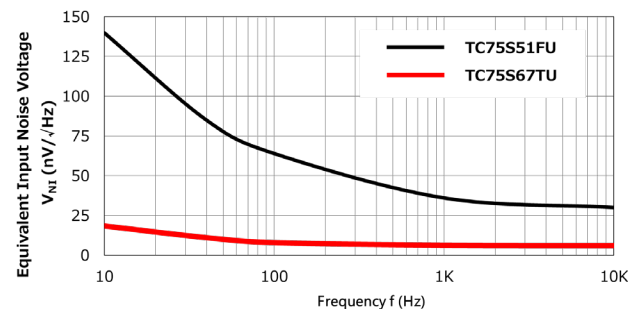
$V_{NI} - f$ @ $T_a = 25$ °C, $V_{DD} = 3.3$ V



Lineup

Part number	TC75S102F	TC75S67TU
Package	SMV 	UFV 
$V_{DD} - V_{SS}$ [V]	1.5 to 5.5	2.2 to 5.5
V_{IO} (Max) [mV]	1.3	3
CMV_{IN} (Max) [V]	V_{DD}	1.4 (@ $V_{DD} = 2.5$ V)
I_{DD} (Typ. / Max) [μA]	0.27 / 0.46 (@ $V_{DD} = 1.5$ V)	430 / 700 (@ $V_{DD} = 2.5$ V)
V_{NI} (Typ.) [$\text{nV}/\sqrt{\text{Hz}}$] @ $f = 1$ kHz	-	6

[Return to Block Diagram TOP](#)

Value provided

DMOS FET is used for the output of drive circuit and realizes low loss. And CMOS input can control directly from controller's I/O, etc.

1 Rich product lineup

In addition to the listed products, we have lineup of various packaged products (such as DIP, SOL, SOP, SSOP, etc.) and source output type products.

2 Built-in output clamp diode

Built-in output clamp diode regenerates the back electromotive force generated by switching of an inductive.

3 Higher current drive is possible

The load can be driven with higher current by connecting multiple outputs in parallel.

Equivalent circuit

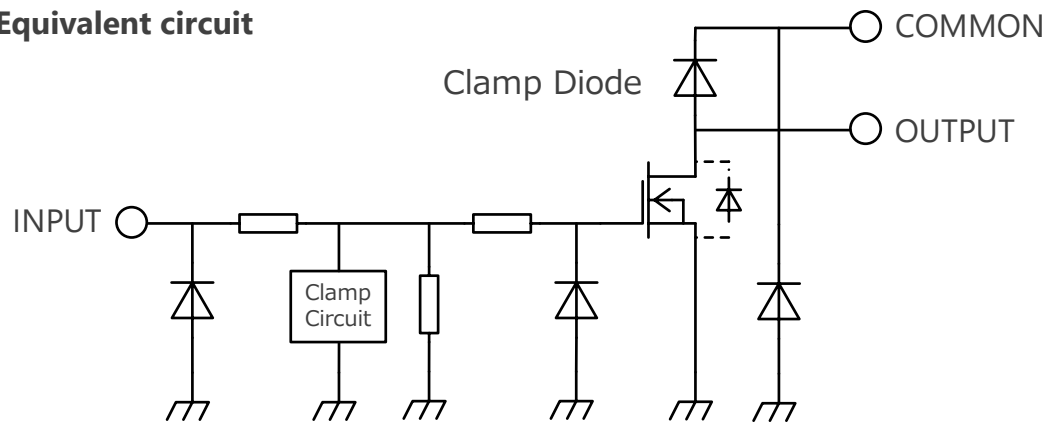

(Note) Equivalent circuit may be simplified for explanatory purpose.

Lineup

Part number	TBD62003AFWG	TBD62083AFG	TBD62064AFAG
Package	P-SOP16-0410-1.27-002	SOP18-P-375-1.27	P-SSOP24-0613-1.00-001
Output type	Sink	Sink	Sink
Number of channels	7ch	8ch	4ch
Input level	H	H	H
I_{OUT} [mA/ch]	500	500	1500
V_{OUT} [V]	50	50	50

[◆Return to Block Diagram TOP](#)

If you are interested in these products and have questions or comments about any of them, please do not hesitate to contact us below:

Contact address: <https://toshiba.semicon-storage.com/ap-en/contact.html>



Terms of use

This terms of use is made between Toshiba Electronic Devices and Storage Corporation (“We”) and Customer who downloads or uses this Reference Design. Customer shall comply with this terms of use. This Reference Design means all documents and data in order to design electronics applications on which our semiconductor device is embedded.

Section 1. Restrictions on usage

1. This Reference Design is provided solely as reference data for designing electronics applications. Customer shall not use this Reference Design for any other purpose, including without limitation, verification of reliability.
2. Customer shall not use this Reference Design for sale, lease or other transfer.
3. Customer shall not use this Reference Design for evaluation in high or low temperature, high humidity, or high electromagnetic environments.
4. This Reference Design shall not be used for or incorporated into any product or system whose manufacture, use, or sale is prohibited under any applicable laws or regulations.

Section 2. Limitations

1. We reserve the right to make changes to this Reference Design without notice.
2. This Reference Design should be treated as a reference only. WE ARE NOT RESPONSIBLE FOR ANY INCORRECT OR INCOMPLETE DATA AND INFORMATION.
3. Semiconductor devices can malfunction or fail. When designing electronics applications by referring to this Reference Design, Customer is responsible for complying with safety standards and for providing adequate designs and safeguards for their hardware, software and systems which minimize risk and avoid situations in which a malfunction or failure of semiconductor devices could cause loss of human life, bodily injury or damage to property, including data loss or corruption. Customer must also refer to and comply with the latest versions of all relevant our information, including without limitation, specifications, data sheets and application notes for semiconductor devices, as well as the precautions and conditions set forth in the "Semiconductor Reliability Handbook".
4. Designing electronics applications by referring to this Reference Design, Customer must evaluate the whole system sufficiently. Customer is solely responsible for applying this Reference Design to Customer's own product design or applications. WE ASSUME NO LIABILITY FOR CUSTOMER'S PRODUCT DESIGN OR APPLICATIONS.
5. WE SHALL NOT BE RESPONSIBLE FOR ANY INFRINGEMENT OF PATENTS OR ANY OTHER INTELLECTUAL PROPERTY RIGHTS OF THIRD PARTIES THAT MAY RESULT FROM THE USE OF THIS REFERENCE DESIGN. NO LICENSE TO ANY INTELLECTUAL PROPERTY RIGHT IS GRANTED BY THIS TERMS OF USE, WHETHER EXPRESS OR IMPLIED, BY ESTOPPEL OR OTHERWISE.
6. THIS REFERENCE DESIGN IS PROVIDED "AS IS". WE (a) ASSUME NO LIABILITY WHATSOEVER, INCLUDING WITHOUT LIMITATION, INDIRECT, CONSEQUENTIAL, SPECIAL, OR INCIDENTAL DAMAGES OR LOSS, INCLUDING WITHOUT LIMITATION, LOSS OF PROFITS, LOSS OF OPPORTUNITIES, BUSINESS INTERRUPTION AND LOSS OF DATA, AND (b) DISCLAIM ANY AND ALL EXPRESS OR IMPLIED WARRANTIES AND CONDITIONS RELATED TO THIS REFERENCE DESIGN, INCLUDING WITHOUT LIMITATION, WARRANTIES OR CONDITIONS OF FUNCTION AND WORKING, WARRANTIES OF MERCHANTABILITY, FITNESS FOR A PARTICULAR PURPOSE, ACCURACY OF INFORMATION, OR NONINFRINGEMENT.

Section 3. Terms and Termination

It is assumed that Customer agrees to any and all this terms of use if Customer downloads or uses this Reference Design. We may, at its sole and exclusive discretion, change, alter, modify, add, and/or remove any part of this terms of use at any time without any prior notice. We may terminate this terms of use at any time and without any cause. Upon termination of this terms of use, Customer shall eliminate this Reference Design. Furthermore, upon our request, Customer shall submit to us a written confirmation to prove elimination of this Reference Design.

Section 4. Export Control

Customer shall not use or otherwise make available this Reference Design for any military purposes, including without limitation, for the design, development, use, stockpiling or manufacturing of nuclear, chemical, or biological weapons or missile technology products (mass destruction weapons). This Reference Design may be controlled under the applicable export laws and regulations including, without limitation, the Japanese Foreign Exchange and Foreign Trade Act and the U.S. Export Administration Regulations. Export and re-export of this Reference Design is strictly prohibited except in compliance with all applicable export laws and regulations.

Section 5. Governing Laws

This terms of use shall be governed and construed by laws of Japan, without reference to conflict of law principle.

Section 6. Jurisdiction

Unless otherwise specified, Tokyo District Court in Tokyo, Japan shall be exclusively the court of first jurisdiction for all disputes under this terms of use.

RESTRICTIONS ON PRODUCT USE

- Toshiba Electronic Devices & Storage Corporation, and its subsidiaries and affiliates (collectively "TOSHIBA"), reserve the right to make changes to the information in this document, and related hardware, software and systems (collectively "Product") without notice.
- This document and any information herein may not be reproduced without prior written permission from TOSHIBA. Even with TOSHIBA's written permission, reproduction is permissible only if reproduction is without alteration/omission.
- Though TOSHIBA works continually to improve Product's quality and reliability, Product can malfunction or fail. Customers are responsible for complying with safety standards and for providing adequate designs and safeguards for their hardware, software and systems which minimize risk and avoid situations in which a malfunction or failure of Product could cause loss of human life, bodily injury or damage to property, including data loss or corruption. Before customers use the Product, create designs including the Product, or incorporate the Product into their own applications, customers must also refer to and comply with (a) the latest versions of all relevant TOSHIBA information, including without limitation, this document, the specifications, the data sheets and application notes for Product and the precautions and conditions set forth in the "TOSHIBA Semiconductor Reliability Handbook" and (b) the instructions for the application with which the Product will be used with or for. Customers are solely responsible for all aspects of their own product design or applications, including but not limited to (a) determining the appropriateness of the use of this Product in such design or applications; (b) evaluating and determining the applicability of any information contained in this document, or in charts, diagrams, programs, algorithms, sample application circuits, or any other referenced documents; and (c) validating all operating parameters for such designs and applications. **TOSHIBA ASSUMES NO LIABILITY FOR CUSTOMERS' PRODUCT DESIGN OR APPLICATIONS.**
- **PRODUCT IS NEITHER INTENDED NOR WARRANTED FOR USE IN EQUIPMENTS OR SYSTEMS THAT REQUIRE EXTRAORDINARILY HIGH LEVELS OF QUALITY AND/OR RELIABILITY, AND/OR A MALFUNCTION OR FAILURE OF WHICH MAY CAUSE LOSS OF HUMAN LIFE, BODILY INJURY, SERIOUS PROPERTY DAMAGE AND/OR SERIOUS PUBLIC IMPACT ("UNINTENDED USE").** Except for specific applications as expressly stated in this document, Unintended Use includes, without limitation, equipment used in nuclear facilities, equipment used in the aerospace industry, lifesaving and/or life supporting medical equipment, equipment used for automobiles, trains, ships and other transportation, traffic signaling equipment, equipment used to control combustions or explosions, safety devices, elevators and escalators, and devices related to power plant. **IF YOU USE PRODUCT FOR UNINTENDED USE, TOSHIBA ASSUMES NO LIABILITY FOR PRODUCT.** For details, please contact your TOSHIBA sales representative or contact us via our website.
- Do not disassemble, analyze, reverse-engineer, alter, modify, translate or copy Product, whether in whole or in part.
- Product shall not be used for or incorporated into any products or systems whose manufacture, use, or sale is prohibited under any applicable laws or regulations.
- The information contained herein is presented only as guidance for Product use. No responsibility is assumed by TOSHIBA for any infringement of patents or any other intellectual property rights of third parties that may result from the use of Product. No license to any intellectual property right is granted by this document, whether express or implied, by estoppel or otherwise.
- **ABSENT A WRITTEN SIGNED AGREEMENT, EXCEPT AS PROVIDED IN THE RELEVANT TERMS AND CONDITIONS OF SALE FOR PRODUCT, AND TO THE MAXIMUM EXTENT ALLOWABLE BY LAW, TOSHIBA (1) ASSUMES NO LIABILITY WHATSOEVER, INCLUDING WITHOUT LIMITATION, INDIRECT, CONSEQUENTIAL, SPECIAL, OR INCIDENTAL DAMAGES OR LOSS, INCLUDING WITHOUT LIMITATION, LOSS OF PROFITS, LOSS OF OPPORTUNITIES, BUSINESS INTERRUPTION AND LOSS OF DATA, AND (2) DISCLAIMS ANY AND ALL EXPRESS OR IMPLIED WARRANTIES AND CONDITIONS RELATED TO SALE, USE OF PRODUCT, OR INFORMATION, INCLUDING WARRANTIES OR CONDITIONS OF MERCHANTABILITY, FITNESS FOR A PARTICULAR PURPOSE, ACCURACY OF INFORMATION, OR NONINFRINGEMENT.**
- Product may include products using GaAs (Gallium Arsenide). GaAs is harmful to humans if consumed or absorbed, whether in the form of dust or vapor. Handle with care and do not break, cut, crush, grind, dissolve chemically or otherwise expose GaAs in Product.
- Do not use or otherwise make available Product or related software or technology for any military purposes, including without limitation, for the design, development, use, stockpiling or manufacturing of nuclear, chemical, or biological weapons or missile technology products (mass destruction weapons). Product and related software and technology may be controlled under the applicable export laws and regulations including, without limitation, the Japanese Foreign Exchange and Foreign Trade Law and the U.S. Export Administration Regulations. Export and re-export of Product or related software or technology are strictly prohibited except in compliance with all applicable export laws and regulations.
- Please contact your TOSHIBA sales representative for details as to environmental matters such as the RoHS compatibility of Product. Please use Product in compliance with all applicable laws and regulations that regulate the inclusion or use of controlled substances, including without limitation, the EU RoHS Directive. **TOSHIBA ASSUMES NO LIABILITY FOR DAMAGES OR LOSSES OCCURRING AS A RESULT OF NONCOMPLIANCE WITH APPLICABLE LAWS AND REGULATIONS.**

TOSHIBA

* PSpice® is a registered trademark of Cadence Design Systems, Inc.

* Arm and Cortex are registered trademarks of Arm Limited (or its subsidiaries) in the US and/or elsewhere.

* TXZ+™ is a trademark of Toshiba Electronic Devices & Storage Corporation

* All other company names, product names, and service names may be trademarks of their respective companies.