

TCR3EM series

300 mA CMOS Low Dropout Regulator

1. Description

The TCR3EM series are CMOS general-purpose single-output voltage regulators with an on/off control input, featuring low dropout voltage and fast load transient response.

These voltage regulators are available in fixed output voltages between 0.8 V and 5.0 V and capable of driving up to 300 mA. They feature Overcurrent protection, Thermal shutdown and Auto-discharge.

The TCR3EM series is offered in the ultra small plastic mold package DFN4D (1.0 mm x 1.0 mm; t 0.37 mm (typ.)) and has a low dropout voltage of 160 mV (2.5 V output, $I_{OUT} = 150$ mA). As small ceramic input and output capacitors 1.0 μ F can be used with the TCR3EM series, these devices are ideal for portable applications that require high-density board assembly such as cellular phones.

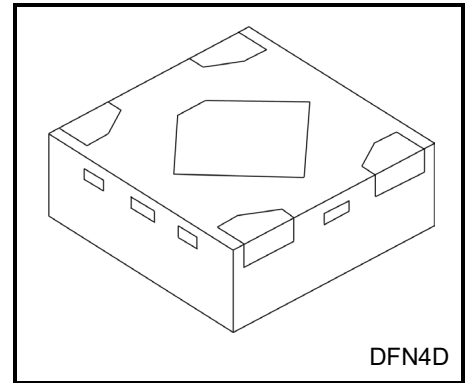

Weight: 1.1 mg (typ.)

2. Applications

Power IC developed for portable applications

3. Features

- Ultra small package DFN4D (1.0 mm x 1.0 mm; t 0.37 mm (typ.)).
- Wide range output voltage line up ($V_{OUT} = 0.8$ to 5.0 V)
- Wide input voltage range ($V_{IN} = 1.3$ to 5.5 V)
- Low control voltage (HIGH) ($V_{CTH} = 0.8$ V (min))
- Low dropout voltage
 $V_{DO} = 160$ mV (typ.) at 2.5 V output, $I_{OUT} = 150$ mA
- High ripple rejection ratio (68 dB (typ.) at 2.5 V output, $I_{OUT} = 10$ mA, $f = 1$ kHz)
- Fast load transient response (-57/+55 mV (typ.) at 2.5 V output, $I_{OUT} = 1$ mA \leftrightarrow 150 mA)
- Overcurrent protection
- Thermal shutdown
- Auto-discharge
- Inrush current protection circuit
- Pull down connection between CONTROL and GND
- Ceramic capacitors can be used ($C_{IN} = 1.0$ μ F, $C_{OUT} = 1.0$ μ F)

Start of commercial production
2024-08

4. Absolute Maximum Ratings (Note) (Ta = 25°C)

Characteristics	Symbol	Rating	Unit
Input voltage	V _{IN}	-0.3 to 6.0	V
Control voltage	V _{CT}	-0.3 to 6.0	V
Output voltage	V _{OUT}	-0.3 to V _{IN} + 0.3 ≤ 6.0	V
Power dissipation	P _D	420 (Note1)	mW
Junction temperature	T _j	150	°C
Storage temperature range	T _{stg}	-55 to 150	°C

Note: Using continuously under heavy loads (e.g. the application of high temperature/current/voltage and the significant change in temperature, etc.) may cause this product to decrease in the reliability significantly even if the operating conditions (i.e. operating temperature/current/voltage, etc.) are within the absolute maximum ratings and the operating ranges.

Please design the appropriate reliability upon reviewing the Toshiba Semiconductor Reliability Handbook (“Handling Precautions”/“Derating Concept and Methods”) and individual reliability data (i.e. reliability test report and estimated failure rate, etc).

Note1: Rating at mounting on a board

Glass epoxy(FR4) board dimension: 40mm x 40mm x 1.6mm, both sides of board.

Metal pattern ratio: a surface approximately 50%, the reverse side approximately 50%

Through hole: diameter 0.5 mm x 24 pcs

5. Pin Assignment (top view)

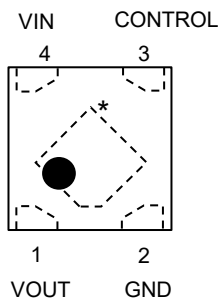

*Center electrode should be connected to GND or Open

6. Operating Ranges

Characteristics	Symbol	Rating	Unit
Input voltage	V _{IN}	1.3 to 5.5 (Note 2)	V
Control voltage	V _{CT}	0 to 5.5	V
Output voltage	V _{OUT}	0.8 to 5.0	V
Output current	I _{OUT}	DC 300	mA
Operation Temperature	T _{opr}	-40 to 85	°C
Output Capacitance	C _{OUT}	≥ 1.0	μF
Input Capacitance	C _{IN}	≥ 1.0	μF

Note 2: Please refer to Dropout Voltage and use it within Absolute Maximum Ratings Junction temperature and Operation Temperature Ranges.

7. List of Products Number, Output voltage and Marking

Product No.	Output voltage(V)	Marking	Product No.	Output voltage(V)	Marking
TCR3EM08A	0.8	0E8	TCR3EM27A*	2.7	2E7
TCR3EM085A*	0.85	0EJ	TCR3EM275A*	2.75	2EM
TCR3EM09A	0.9	0E9	TCR3EM28A	2.8	2E8
TCR3EM095A*	0.95	0EK	TCR3EM285A*	2.85	2ED
TCR3EM10A*	1.0	1E0	TCR3EM29A*	2.9	2E9
TCR3EM105A*	1.05	1EA	TCR3EM295A*	2.95	2EK
TCR3EM11A	1.1	1E1	TCR3EM30A*	3.0	3E0
TCR3EM115A*	1.15	1EB	TCR3EM305A*	3.05	3EA
TCR3EM12A	1.2	1E2	TCR3EM31A*	3.1	3E1
TCR3EM125A*	1.25	1EC	TCR3EM32A*	3.2	3E2
TCR3EM13A*	1.3	1E3	TCR3EM33A	3.3	3E3
TCR3EM135A*	1.35	1ED	TCR3EM335A*	3.35	3ED
TCR3EM14A*	1.4	1E4	TCR3EM34A	3.4	3E4
TCR3EM145A*	1.45	1EL	TCR3EM35A*	3.5	3E5
TCR3EM15A*	1.5	1E5	TCR3EM36A*	3.6	3E6
TCR3EM17A	1.7	1E7	TCR3EM39A*	3.9	3E9
TCR3EM18A	1.8	1E8	TCR3EM40A*	4.0	4E0
TCR3EM185A*	1.85	1EG	TCR3EM41A*	4.1	4E1
TCR3EM19A*	1.9	1E9	TCR3EM42A*	4.2	4E2
TCR3EM20A	2.0	2E0	TCR3EM45A*	4.5	4E5
TCR3EM24A*	2.4	2E4	TCR3EM48A*	4.8	4E8
TCR3EM25A	2.5	2E5	TCR3EM50A	5.0	5E0

* Please contact your local Toshiba representative if you are interested in products with * sign.

Top Marking (top view)

Example: TCR3EM25A (2.5 V output)

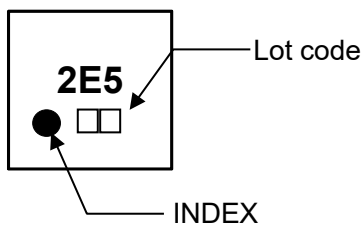

8. Block Diagram

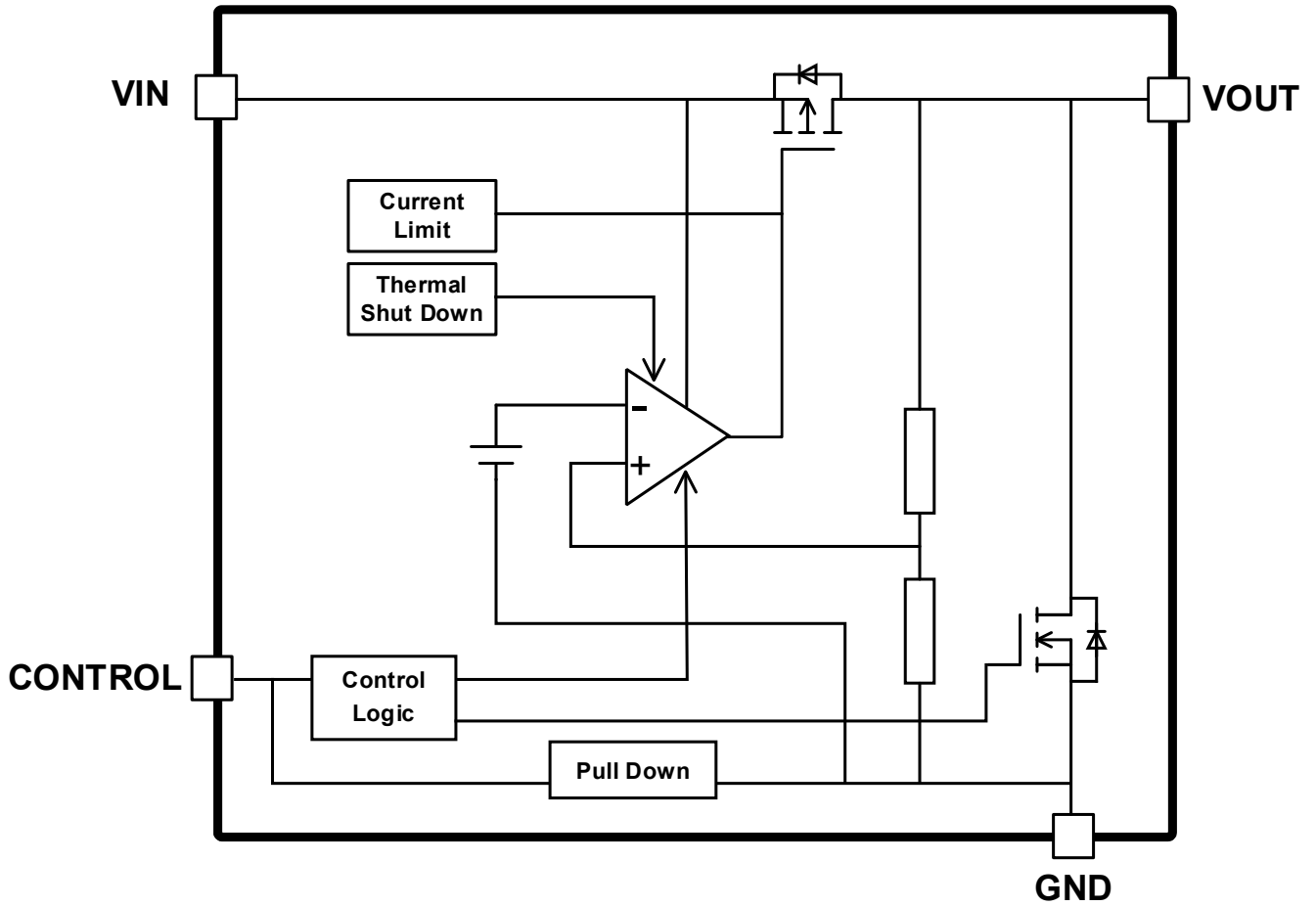

9. Electrical Characteristics

(Unless otherwise specified, $V_{IN} = 2.5\text{ V}$ or $V_{OUT} + 1\text{ V}$ (whichever is greater), $V_{IN} = 5.5\text{ V}$ ($V_{OUT} > 4.5\text{ V}$), $C_{IN} = C_{OUT} = 1.0\text{ }\mu\text{F}$)

Characteristics	Symbol	Test Condition	$T_j = 25^\circ\text{C}$			$T_j = -40\text{ to }85^\circ\text{C}$ (Note 8)		Unit	
			Min	Typ.	Max	Min	Max		
Output voltage accuracy	V_{OUT}	$I_{OUT} = 50\text{ mA}$ $V_{IN} = V_{OUT} + 1\text{ V}$ (Note 3)	$V_{OUT} < 1.8\text{ V}$	-18	—	+18	—	—	mV
			$1.8\text{ V} \leq V_{OUT}$	-1	—	+1	—	—	%
Line regulation	Reg·line	$V_{OUT} + 0.5\text{ V} \leq V_{IN} \leq 5.5\text{ V}$ $I_{OUT} = 1\text{ mA}$	—	1	—	—	10	mV	
Load regulation	Reg·load	$1\text{ mA} \leq I_{OUT} \leq 300\text{ mA}$	—	17	—	—	59	mV	
Quiescent current	$I_{B(ON)}$	$I_{OUT} = 0\text{ mA}$, $V_{IN} = 5.5\text{ V}$ (Note 5)	—	35	—	—	55	μA	
Stand-by current	$I_{B(OFF)}$	$V_{CT} = 0\text{ V}$, $V_{IN} = 5.5\text{ V}$ (Note 5)	—	0.1	—	—	1.0	μA	
Control pull down current	I_{CT}	—	—	0.1	—	—	0.2	μA	
Drop-out voltage (Note 9)	V_{DO}	$I_{OUT} = 150\text{ mA}$ (Note 4)	—	160	—	—	218	mV	
		$I_{OUT} = 300\text{ mA}$ (Note 4)	—	330	—	—	417	mV	
Output noise voltage	V_{NO}	$I_{OUT} = 10\text{ mA}$ $10\text{ Hz} \leq f \leq 100\text{ kHz}$, $T_a = 25^\circ\text{C}$ (Note 4)	—	50	—	—	—	μV_{rms}	
Ripple rejection ratio	R.R.	$V_{IN} = 3.5\text{ V}$ $V_{OUT} = 2.5\text{ V}$ $I_{OUT} = 10\text{ mA}$, $V_{Ripple} = 500\text{ mV}_{p-p}$, $T_a = 25^\circ\text{C}$ (Note 4)	$f = 100\text{ Hz}$	—	80	—	—	—	dB
			$f = 1\text{ kHz}$	—	68	—	—	—	
			$f = 10\text{ kHz}$	—	55	—	—	—	
			$f = 100\text{ kHz}$	—	43	—	—	—	
			$f = 1\text{ MHz}$	—	43	—	—	—	
Load transient response	ΔV_{OUT}	$I_{OUT} = 1\text{ mA} \rightarrow 150\text{ mA}$ (Note 4) (Note 6)	—	-57	—	—	—	mV	
		$I_{OUT} = 150\text{ mA} \rightarrow 1\text{ mA}$ (Note 4) (Note 6)	—	+55	—	—	—		
		$I_{OUT} = 1\text{ mA} \rightarrow 300\text{ mA}$ (Note 4) (Note 6)	—	-95	—	—	—		
		$I_{OUT} = 300\text{ mA} \rightarrow 1\text{ mA}$ (Note 4) (Note 6)	—	+100	—	—	—		
Output current limit	I_{CL}	$V_{OUT} = V_{OUT(NOM)} * 90\%$ (Note 7)	—	—	—	310	550	mA	
Thermal shutdown threshold	T_{SDH}	T_j rising	—	160	—	—	—	$^\circ\text{C}$	
	T_{SDL}	T_j falling	—	140	—	—	—	$^\circ\text{C}$	
Control voltage (HIGH)	V_{CTH}	Control pin input voltage "HIGH"	—	—	—	0.8	5.5	V	
Control voltage (LOW)	V_{CTL}	Control pin input voltage "LOW"	—	—	—	—	0.4	V	
Discharge on resistance	RSD	(Note 4)	—	25	—	—	—	Ω	

Note 3: stable state with fixed I_{OUT} condition

Note 4: $V_{OUT} = 2.5\text{ V}$

Note 5: except Control pull down current (I_{CT})

Note 6: $t_r = t_f = 1.5\text{ }\mu\text{s}$

Note 7: Pulse measurement

Note 8: This parameter is warranted by design.

Note 9: $V_{DO} = V_{IN1} - (V_{OUT1} \times 0.97)$

V_{OUT1} is the output voltage when $V_{IN} = V_{OUT}$ (nominal voltage) + 1.0 V

V_{IN1} is the input voltage at which the output voltage becomes 97% of V_{OUT1} after gradually decreasing the input voltage.

10. Drop-out voltage table

($C_{IN} = 1.0 \mu\text{F}$, $C_{OUT} = 1.0 \mu\text{F}$)

Output voltages	Symbol	$I_{OUT} = 150 \text{ mA}$					$I_{OUT} = 300 \text{ mA}$					Unit
		$T_j = 25^\circ\text{C}$			$T_j = -40 \text{ to } 85^\circ\text{C}$ (Note 10)		$T_j = 25^\circ\text{C}$			$T_j = -40 \text{ to } 85^\circ\text{C}$ (Note 10)		
		Min	Typ.	Max	Min	Max	Min	Typ.	Max	Min	Max	
$0.8 \text{ V} \leq V_{OUT} \leq 1.15 \text{ V}$	VIN-VOUT	—	687	—	—	773	—	1050 (Note 11)	—	—	1165 (Note 11)	mV
$1.2 \text{ V} \leq V_{OUT} \leq 1.45 \text{ V}$		—	434	—	—	505	—	755 (Note 11)	—	—	858 (Note 11)	
$1.5 \text{ V} \leq V_{OUT} \leq 1.7 \text{ V}$		—	371	—	—	439	—	655	—	—	756	
$1.8 \text{ V} \leq V_{OUT} \leq 1.9 \text{ V}$		—	309	—	—	373	—	559	—	—	655	
$2.0 \text{ V} \leq V_{OUT} \leq 2.4 \text{ V}$		—	267	—	—	328	—	493	—	—	587	
$2.5 \text{ V} \leq V_{OUT} \leq 2.75 \text{ V}$		—	160	—	—	218	—	330	—	—	417	
$2.8 \text{ V} \leq V_{OUT} \leq 2.95 \text{ V}$		—	156	—	—	210	—	315	—	—	401	
$3.0 \text{ V} \leq V_{OUT} \leq 3.2 \text{ V}$		—	151	—	—	205	—	305	—	—	390	
$3.3 \text{ V} \leq V_{OUT} \leq 3.5 \text{ V}$		—	144	—	—	198	—	290	—	—	373	
$3.6 \text{ V} \leq V_{OUT} \leq 4.1 \text{ V}$		—	137	—	—	190	—	275	—	—	357	
$4.2 \text{ V} \leq V_{OUT} \leq 5.0 \text{ V}$		—	122	—	—	174	—	245	—	—	324	

Note 10: This parameter is warranted by design.

Note 11: Operating Voltage of V_{IN} should be over 2.5 V.

11. Application Note

11.1. Recommended Application Circuit

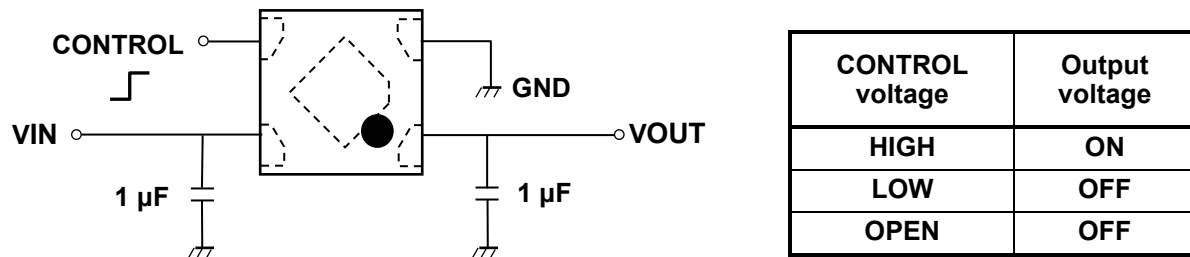

The figure above shows the recommended configuration for using a Low-Dropout regulator. Insert a capacitor at VOUT and VIN pins for stable input/output operation. (Ceramic capacitors can be used).

11.2. Power Dissipation

Board-mounted power dissipation ratings for TCR3EM series are available in the Absolute Maximum Ratings table. Power dissipation is measured on the board condition shown below.

[The Board Condition]

Board material: Glass epoxy (FR4)

Board dimension: 40 mm x 40 mm (both sides of board), t= 1.6 mm

Metal pattern ratio: a surface approximately 50%, the reverse side approximately 50%

Through hole: diameter 0.5 mm x 24 pcs

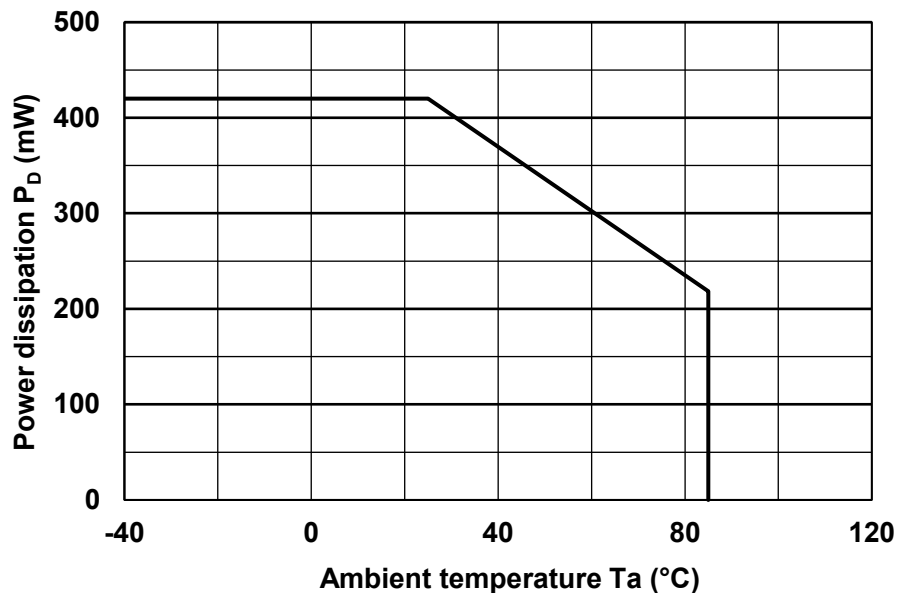

11.3. Attention in Use

- **Output Capacitors**
Ceramic capacitors can be used for these devices. However, because of the type of the capacitors, there might be unexpected thermal features. Please consider application condition for selecting capacitors. And Toshiba recommend ceramic capacitor.
- **V_{OUT} rise time**
Due to the circuit for inrush current reduction, V_{OUT} rise time changes depends on usage condition, surrounding circuit, and surrounding temperature. Therefore, please design with full consideration of usage condition. For example, V_{OUT} becomes stable approximately after 200 μ s from V_{CT} apply timing in $C_{OUT} = 1.0 \mu$ F, $T_a = 25^\circ$ C condition.
- **Mounting**
The long distance between IC and output capacitor might affect phase assurance by impedance in wire and inductor. For stable power supply, output capacitor need to mount near IC as much as possible. Also VIN and GND pattern need to be large and make the wire impedance small as possible.
- **Permissible Loss**
Please have enough design patterns for expected maximum permissible loss. And under consideration of surrounding temperature, input voltage, and output current etc., we recommend proper dissipation ratings for maximum permissible loss; in general maximum dissipation rating is 70 to 80 %.
- **Over current Protection and Thermal shut down function**
Over current protection and Thermal shut down function are designed in these products, but these are not designed to constantly ensure the suppression of the device within operation limits. Depending on the condition during actual usage, it could affect the electrical characteristic specification and reliability. Also note that if output pins and GND pins are not completely shorted out, these products might be break down. When using these products, please read through and understand the concept of dissipation for absolute maximum ratings from the above mention or our 'Semiconductor Reliability Handbook'. Then use these products under absolute maximum ratings in any condition. Furthermore, Toshiba recommend inserting failsafe system into the design.

12. Representation Typical Characteristics (Note)

12.1. Output Voltage vs. Output Current

($V_{IN} = 2.5\text{ V}$ ($V_{OUT} = 0.8\text{ V}$) or 3.5 V ($V_{OUT} = 2.5\text{ V}$) or 5.5 V ($V_{OUT} = 5.0\text{ V}$))

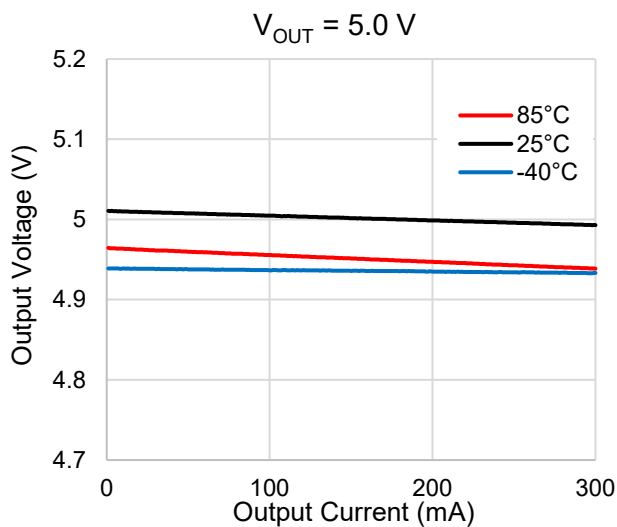
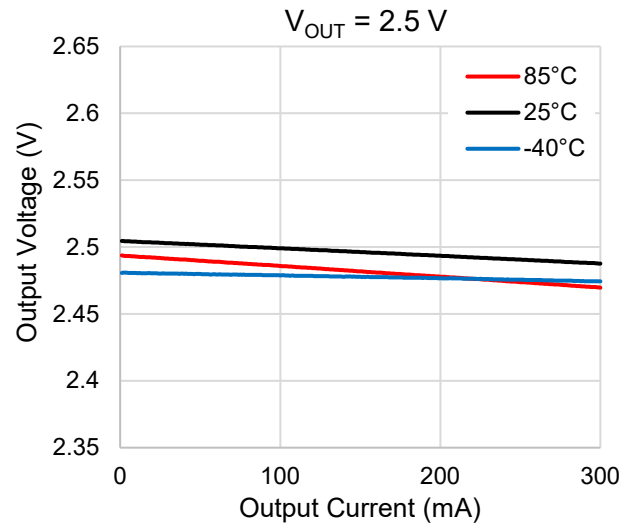
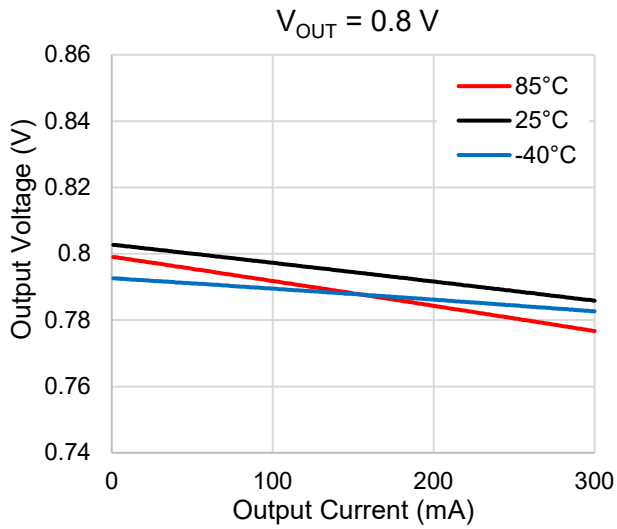

Note: The above characteristics curves are presented for reference only and not guaranteed by production test, unless otherwise noted.

12.2. Output Voltage vs. Input Voltage

($I_{OUT} = 1\text{ mA}$)

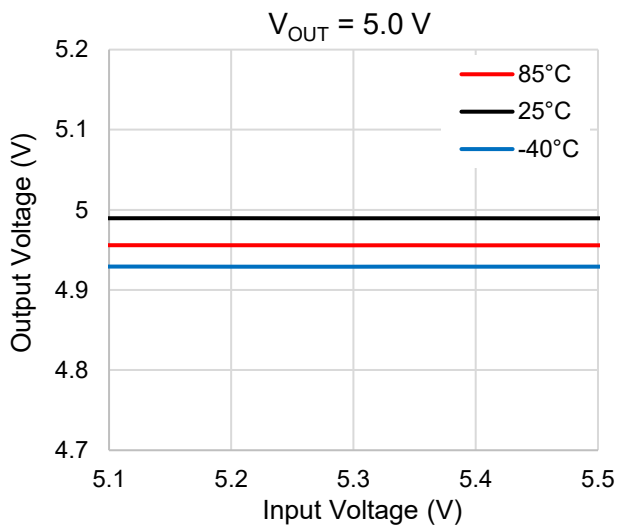
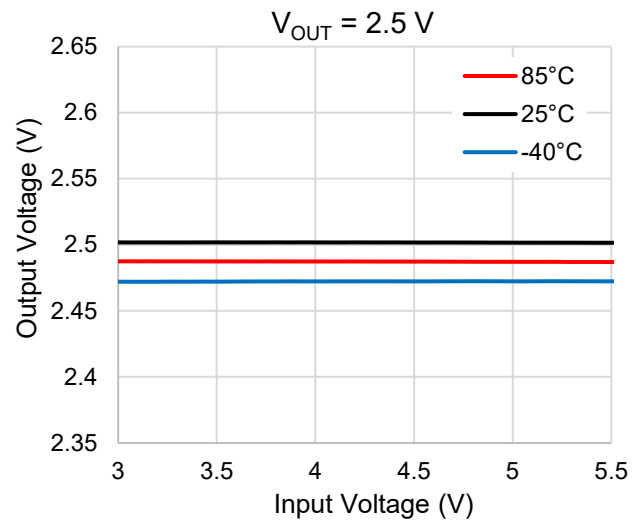
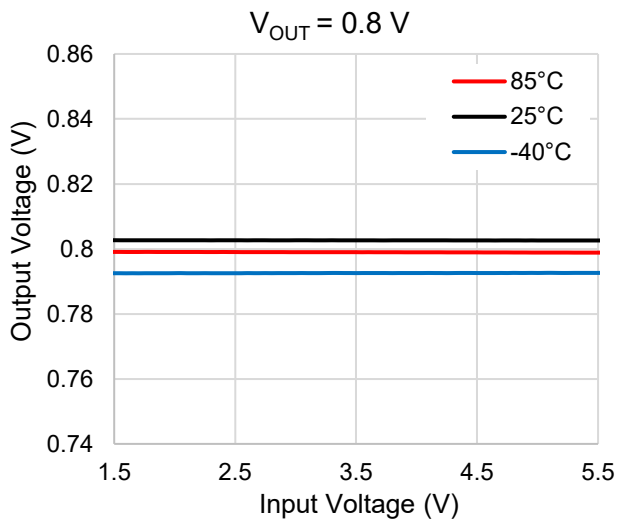

Note: The above characteristics curves are presented for reference only and not guaranteed by production test, unless otherwise noted.

12.3. Dropout Voltage vs. Output Current

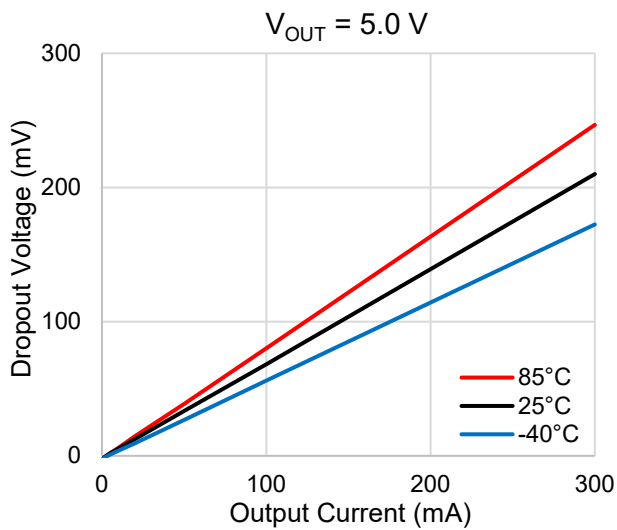
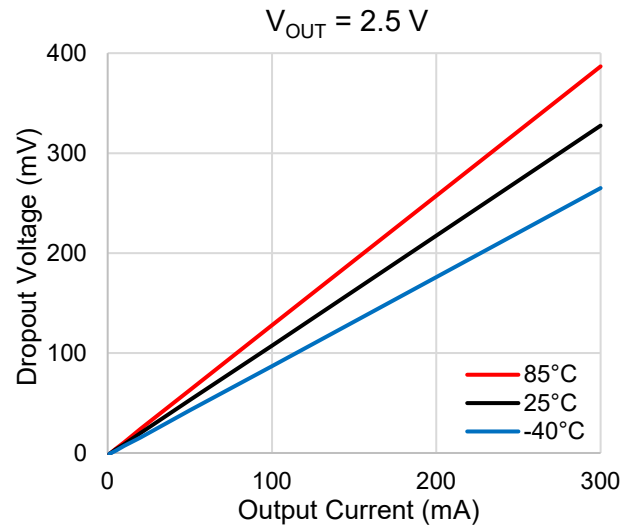
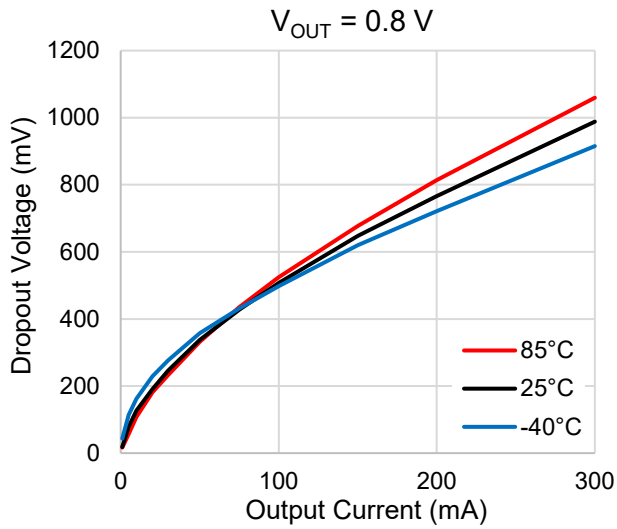

Note: The above characteristics curves are presented for reference only and not guaranteed by production test, unless otherwise noted.

12.4. Quiescent Current vs. Input Voltage

($I_{OUT} = 0 \text{ mA}$)

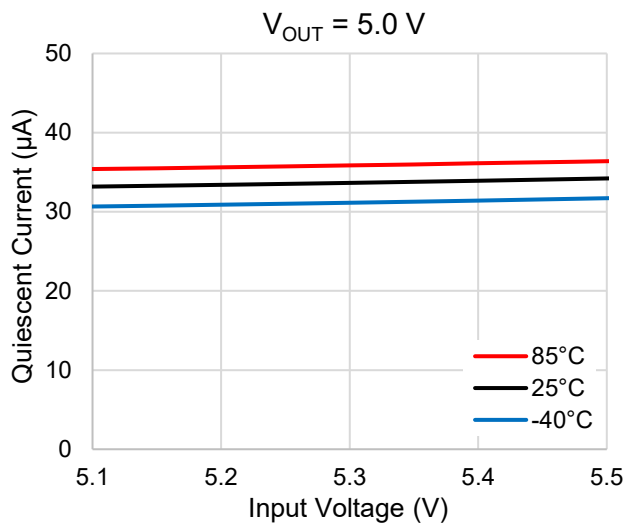
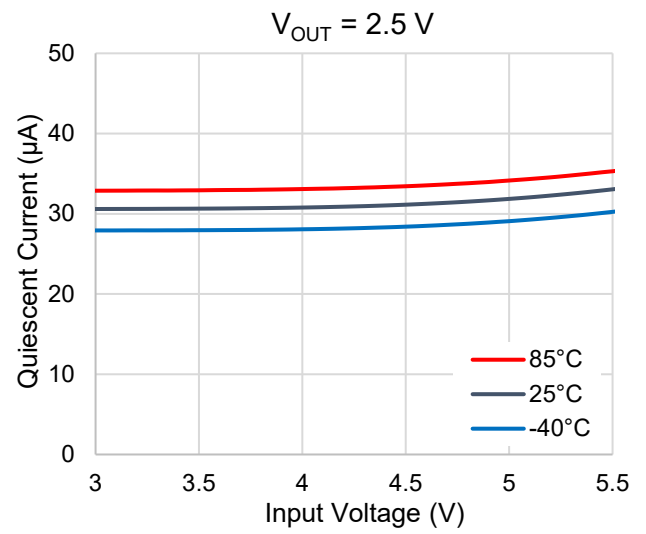
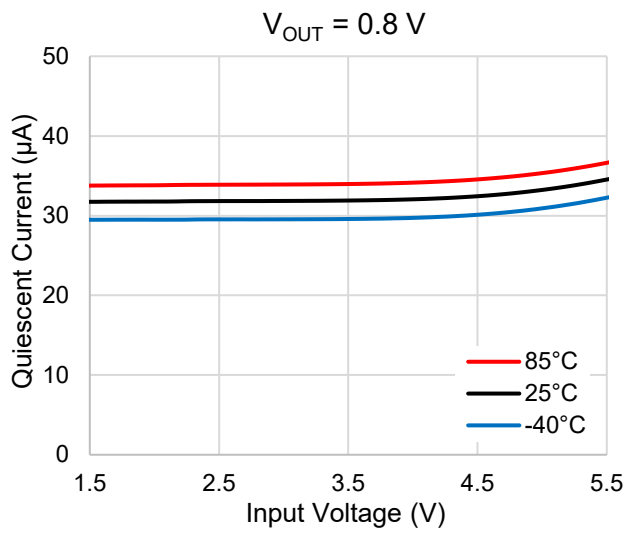

Note: The above characteristics curves are presented for reference only and not guaranteed by production test, unless otherwise noted.

12.5. Output Current Limit

($V_{IN} = 2.5\text{ V}$ ($V_{OUT} = 0.8\text{ V}$) or 3.5 V ($V_{OUT} = 2.5\text{ V}$) or 5.5 V ($V_{OUT} = 5.0\text{ V}$))

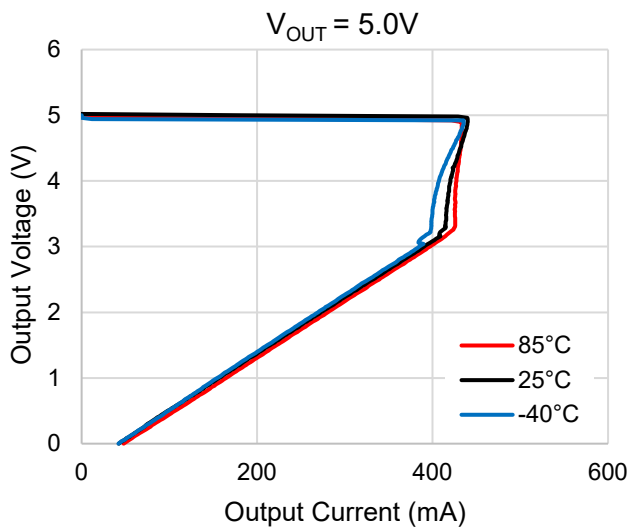
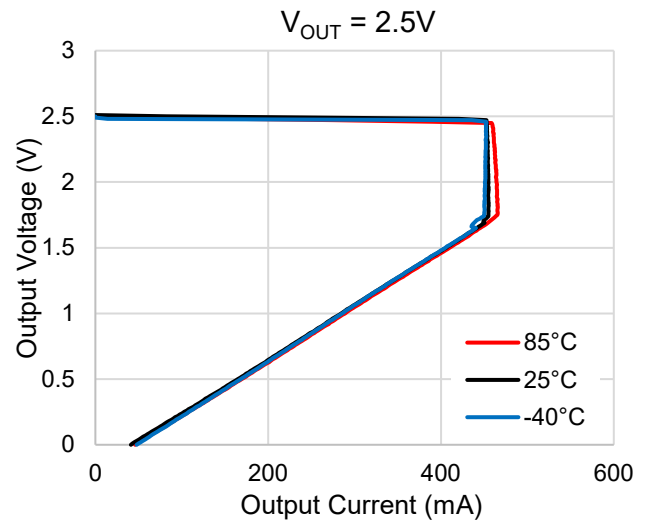
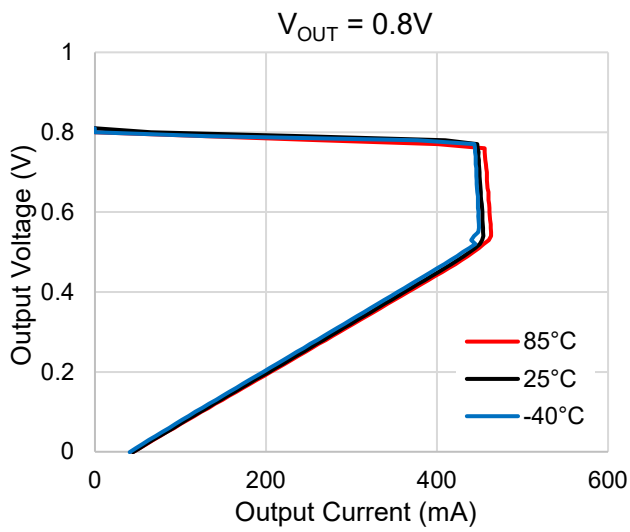

Note: The above characteristics curves are presented for reference only and not guaranteed by production test, unless otherwise noted.

12.6. Ripple rejection Ratio vs. Frequency

(C_{IN} = none, C_{OUT} = 1.0 μ F, V_{IN} = 2.5 V (V_{OUT} = 0.8 V) or 3.5 V (V_{OUT} = 2.5 V) or 5.5 V (V_{OUT} = 5.0 V), V_{IN} Ripple = 500 mV_{p-p}, I_{OUT} = 10 mA, T_a = 25°C)

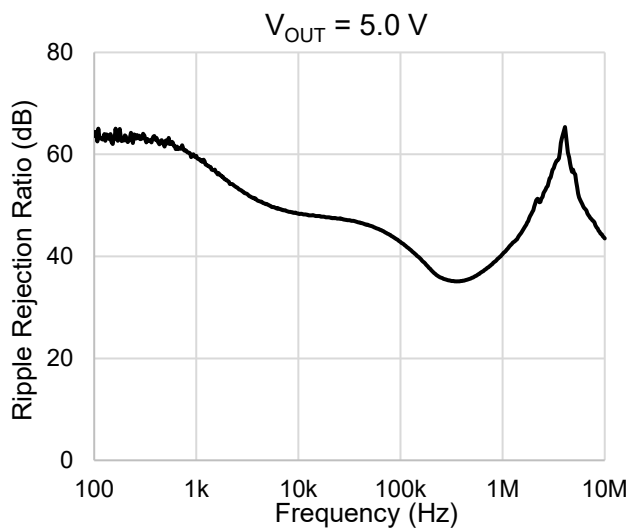
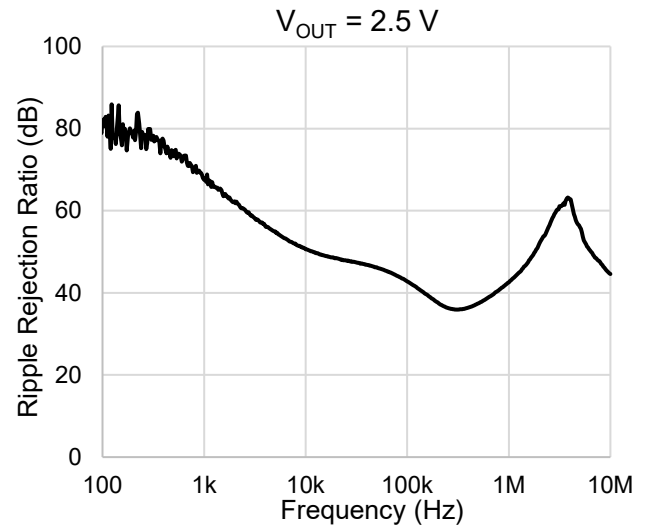
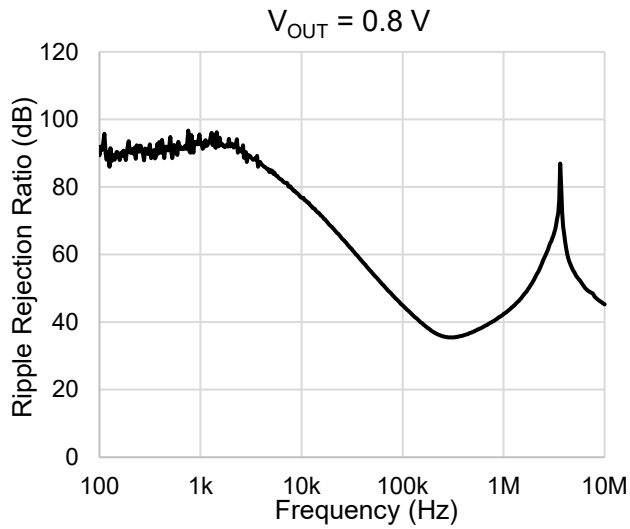

Note: The above characteristics curves are presented for reference only and not guaranteed by production test, unless otherwise noted.

12.7. Load Transient Response

($C_{IN} = 1.0 \mu F$, $C_{OUT} = 1.0 \mu F$, $V_{IN} = 2.5 V$ ($V_{OUT} = 0.8 V$) or $3.5 V$ ($V_{OUT} = 2.5 V$) or $5.5 V$ ($V_{OUT} = 5.0 V$),
 $t_r = 1.5 \mu s$, $t_f = 1.5 \mu s$, $T_a = 25^\circ C$)

- $I_{OUT} = 1 mA \Leftrightarrow 150 mA$

$V_{OUT} = 0.8 V$

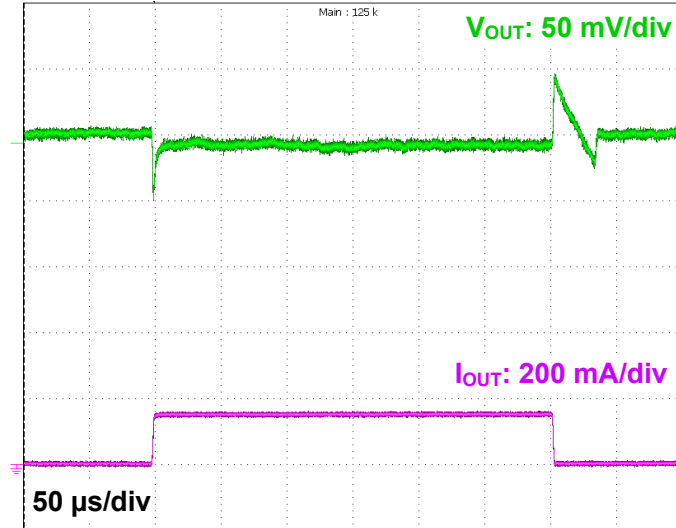

$V_{OUT} = 2.5 V$

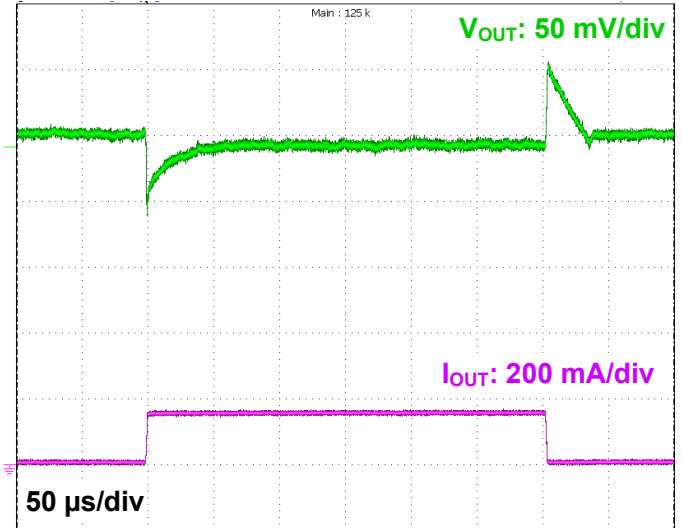

$V_{OUT} = 5.0 V$

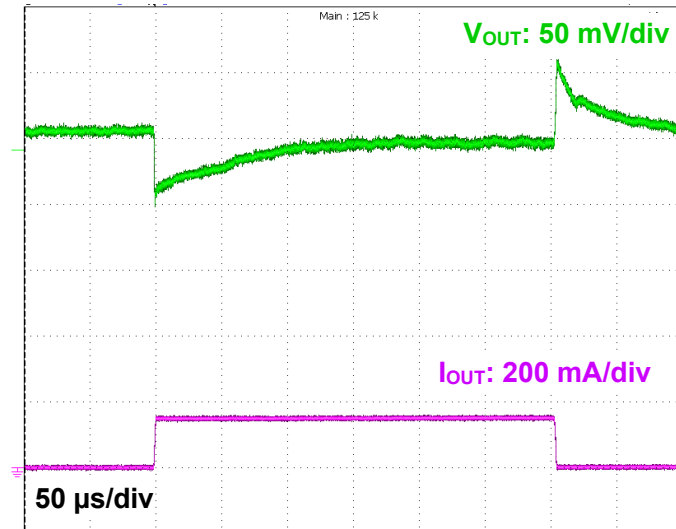

Note: The above characteristics curves are presented for reference only and not guaranteed by production test, unless otherwise noted.

- $I_{OUT} = 1\text{ mA} \leftrightarrow 300\text{ mA}$

$V_{OUT} = 0.8\text{ V}$

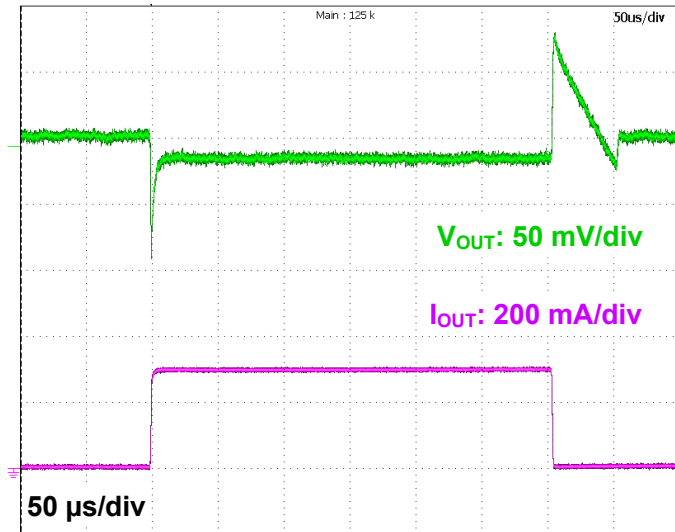

$V_{OUT} = 2.5\text{ V}$

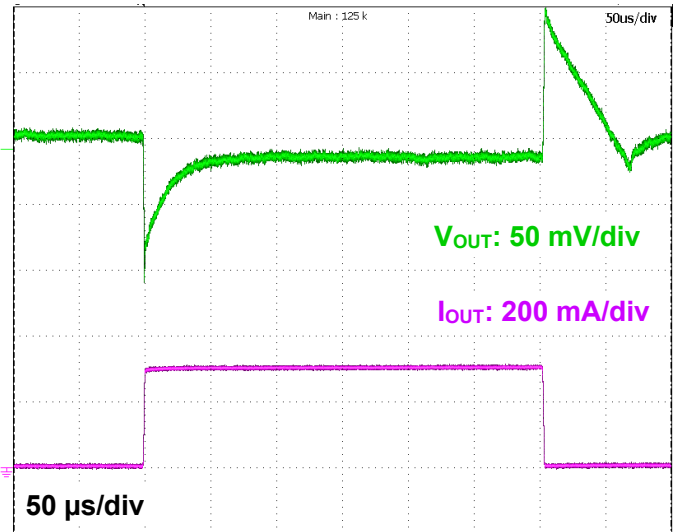

$V_{OUT} = 5.0\text{ V}$

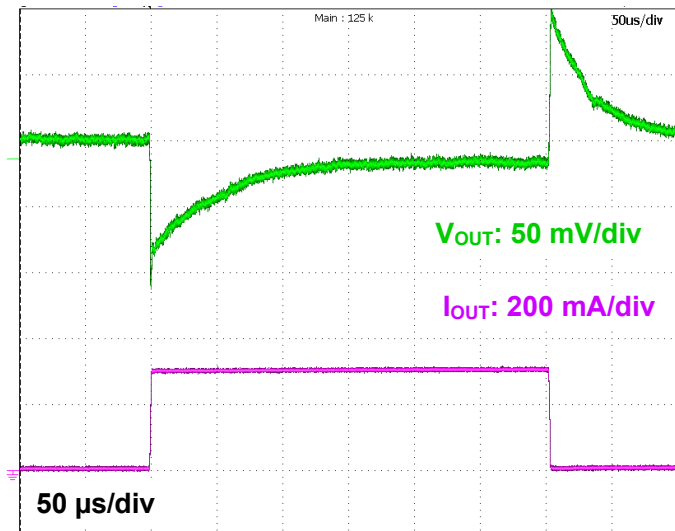

Note: The above characteristics curves are presented for reference only and not guaranteed by production test, unless otherwise noted.

12.8. t_{ON} / t_{OFF} Response

($C_{IN} = 1.0 \mu F$, $C_{OUT} = 1.0 \mu F$, $V_{IN} = 2.5 V$ ($V_{OUT} = 0.8 V$) or $3.5 V$ ($V_{OUT} = 2.5 V$) or $5.5 V$ ($V_{OUT} = 5.0 V$),
 $V_{CT} = 0 V \leftrightarrow 1.0 V$, $T_a = 25^\circ C$)

- $I_{OUT} = 0 mA$

$V_{OUT} = 0.8 V$

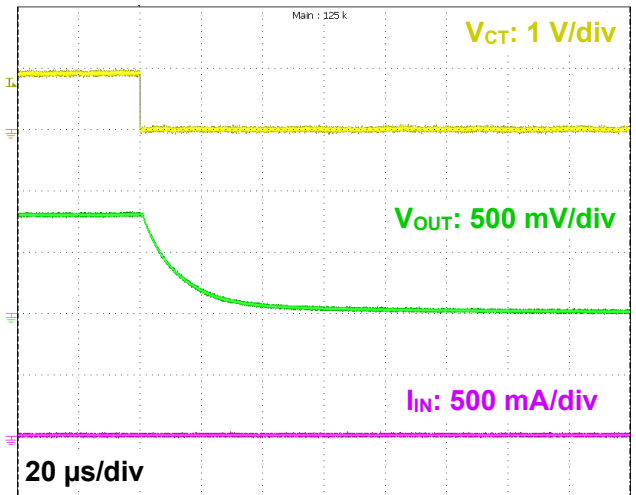
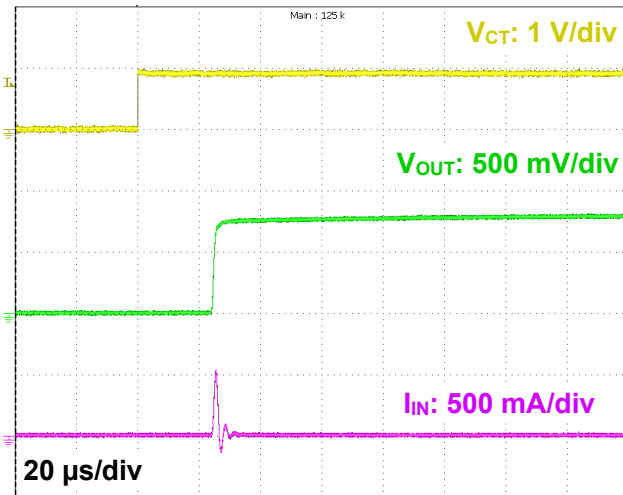

$V_{OUT} = 2.5 V$

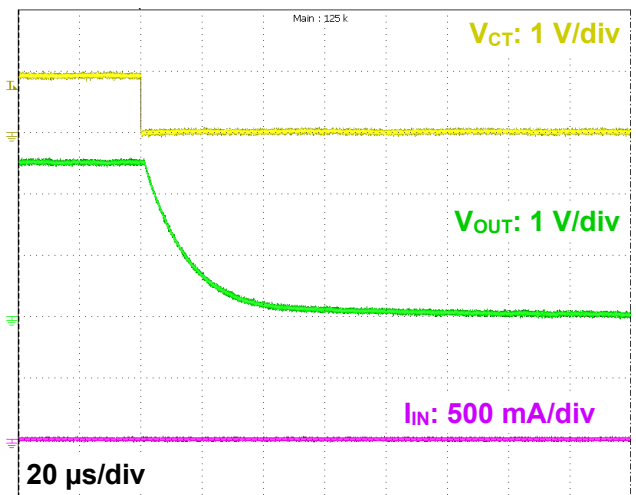
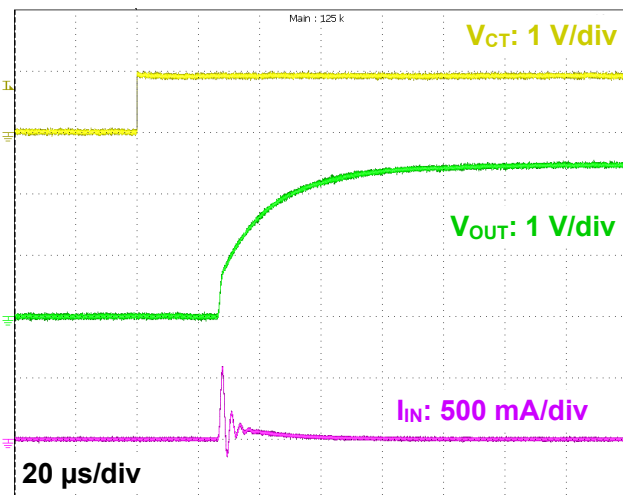

$V_{OUT} = 5.0 V$

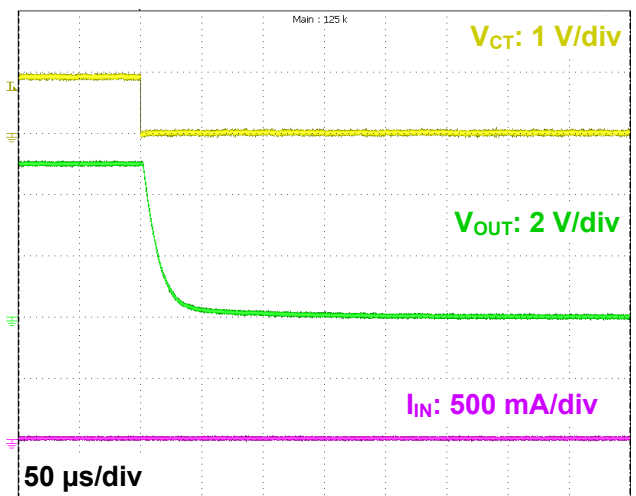
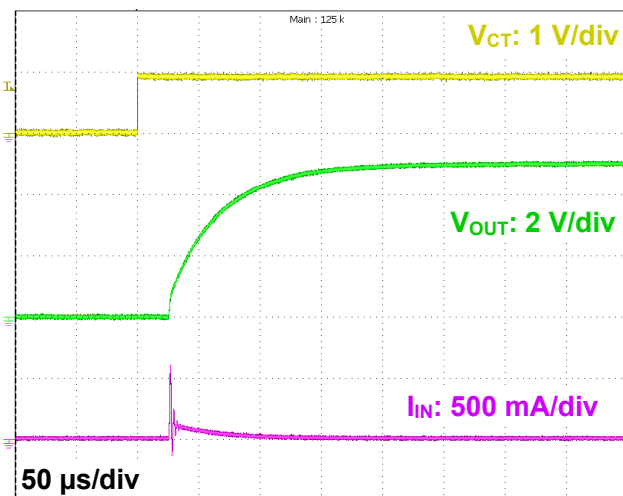

Note: The above characteristics curves are presented for reference only and not guaranteed by production test, unless otherwise noted.

● $I_{OUT} = 300\text{ mA}$

$V_{OUT} = 0.8\text{ V}$

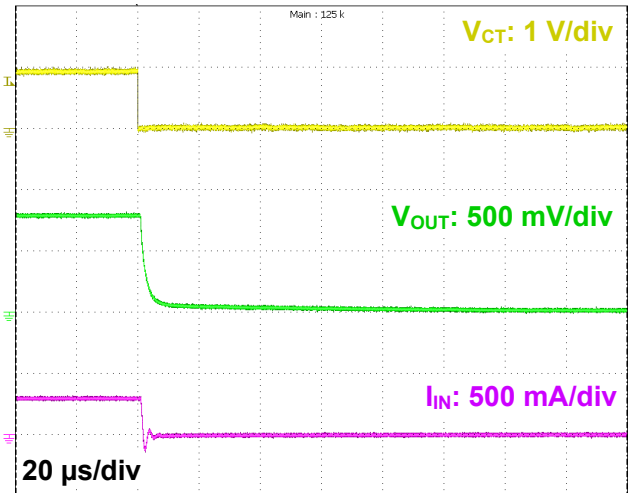
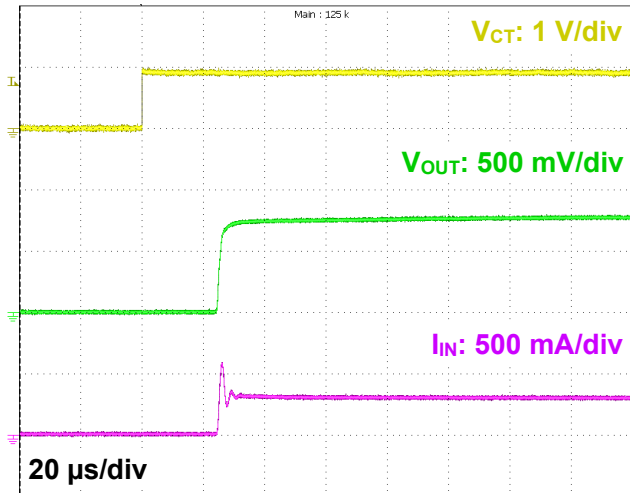

$V_{OUT} = 2.5\text{ V}$

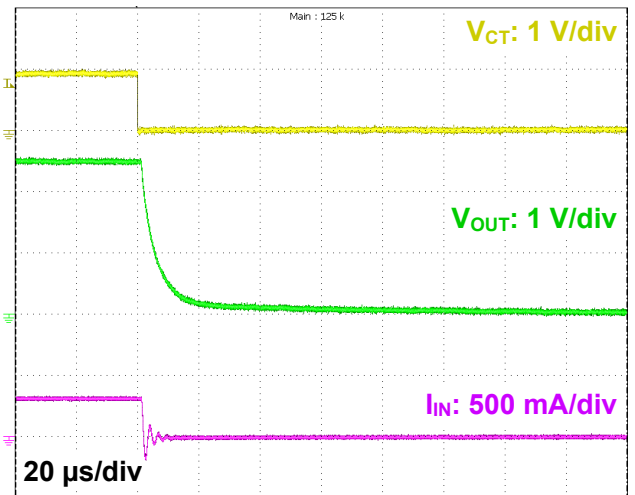
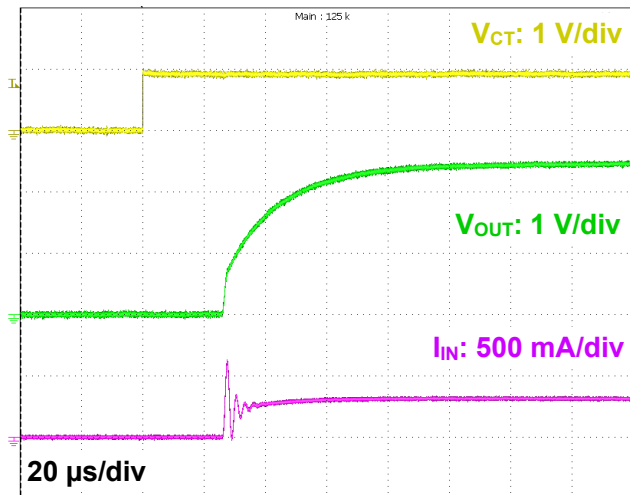

$V_{OUT} = 5.0\text{ V}$

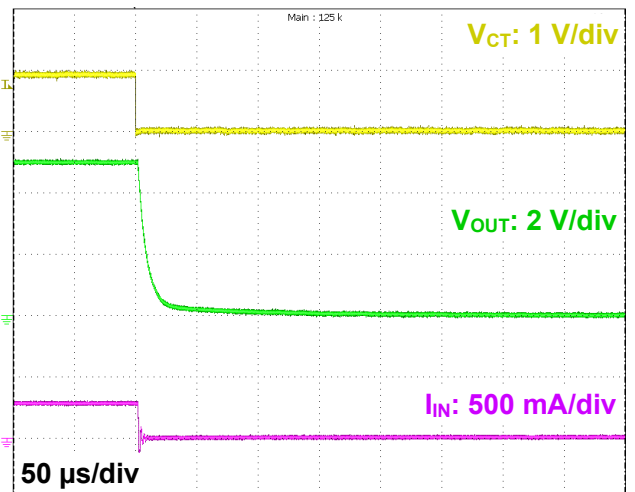
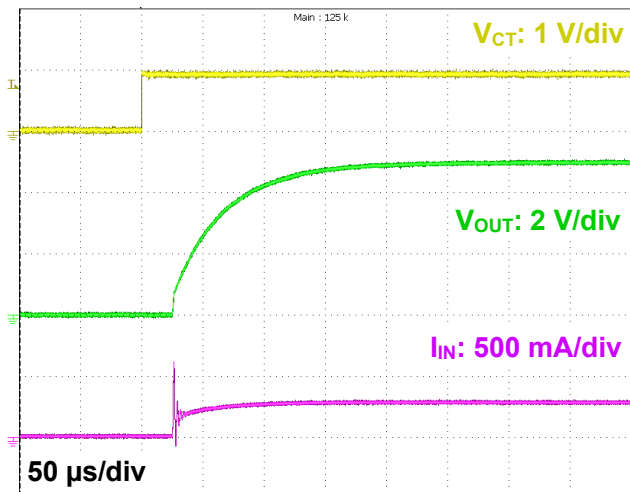

Note: The above characteristics curves are presented for reference only and not guaranteed by production test, unless otherwise noted.

13. Package Information

DFN4D

Unit: mm

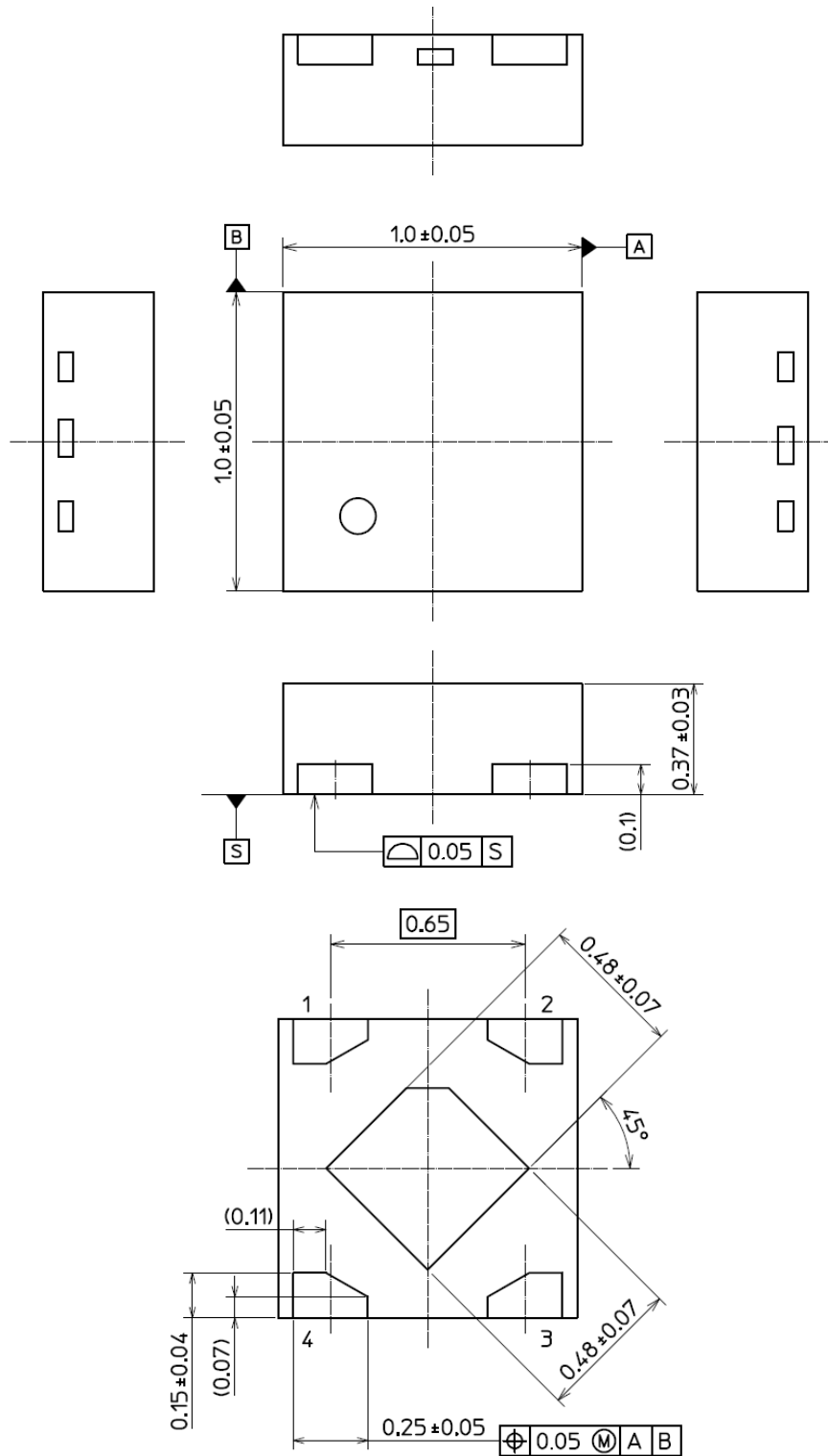

Weight: 1.1 mg (typ.)

14. Land pattern Dimensions (for reference only)

Unit: mm

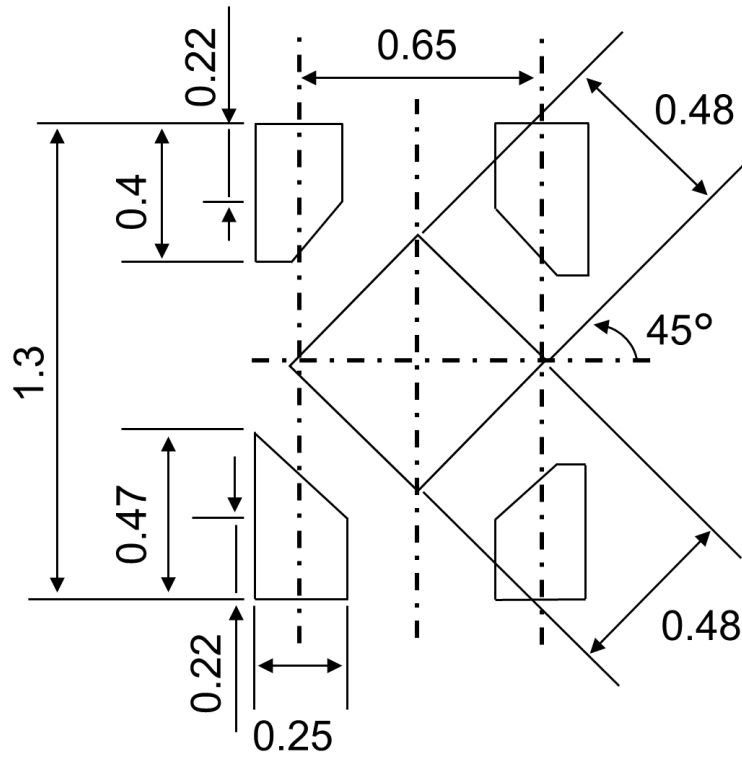

RESTRICTIONS ON PRODUCT USE

Toshiba Corporation and its subsidiaries and affiliates are collectively referred to as "TOSHIBA".

Hardware, software and systems described in this document are collectively referred to as "Product".

- TOSHIBA reserves the right to make changes to the information in this document and related Product without notice.
- This document and any information herein may not be reproduced without prior written permission from TOSHIBA. Even with TOSHIBA's written permission, reproduction is permissible only if reproduction is without alteration/omission.
- Though TOSHIBA works continually to improve Product's quality and reliability, Product can malfunction or fail. Customers are responsible for complying with safety standards and for providing adequate designs and safeguards for their hardware, software and systems which minimize risk and avoid situations in which a malfunction or failure of Product could cause loss of human life, bodily injury or damage to property, including data loss or corruption. Before customers use the Product, create designs including the Product, or incorporate the Product into their own applications, customers must also refer to and comply with (a) the latest versions of all relevant TOSHIBA information, including without limitation, this document, the specifications, the data sheets and application notes for Product and the precautions and conditions set forth in the "TOSHIBA Semiconductor Reliability Handbook" and (b) the instructions for the application with which the Product will be used with or for. Customers are solely responsible for all aspects of their own product design or applications, including but not limited to (a) determining the appropriateness of the use of this Product in such design or applications; (b) evaluating and determining the applicability of any information contained in this document, or in charts, diagrams, programs, algorithms, sample application circuits, or any other referenced documents; and (c) validating all operating parameters for such designs and applications. **TOSHIBA ASSUMES NO LIABILITY FOR CUSTOMERS' PRODUCT DESIGN OR APPLICATIONS.**
- **PRODUCT IS NEITHER INTENDED NOR WARRANTED FOR USE IN EQUIPMENTS OR SYSTEMS THAT REQUIRE EXTRAORDINARILY HIGH LEVELS OF QUALITY AND/OR RELIABILITY, AND/OR A MALFUNCTION OR FAILURE OF WHICH MAY CAUSE LOSS OF HUMAN LIFE, BODILY INJURY, SERIOUS PROPERTY DAMAGE AND/OR SERIOUS PUBLIC IMPACT ("UNINTENDED USE").** Except for specific applications as expressly stated in this document, Unintended Use includes, without limitation, equipment used in nuclear facilities, equipment used in the aerospace industry, Class 3 medical devices, equipment used for automobiles, and military vehicles and munitions. **IF YOU USE PRODUCT FOR UNINTENDED USE, TOSHIBA ASSUMES NO LIABILITY FOR PRODUCT.** For details, please contact your TOSHIBA sales representative or contact us via our website.
- Do not disassemble, analyze, reverse-engineer, alter, modify, translate or copy Product, whether in whole or in part.
- Product shall not be used for or incorporated into any products or systems whose manufacture, use, or sale is prohibited under any applicable laws or regulations.
- The information contained herein is presented only as guidance for Product use. No responsibility is assumed by TOSHIBA for any infringement of patents or any other intellectual property rights of third parties that may result from the use of Product. No license to any intellectual property right is granted by this document, whether express or implied, by estoppel or otherwise.
- **ABSENT A WRITTEN SIGNED AGREEMENT, EXCEPT AS PROVIDED IN THE RELEVANT TERMS AND CONDITIONS OF SALE FOR PRODUCT, AND TO THE MAXIMUM EXTENT ALLOWABLE BY LAW, TOSHIBA (1) ASSUMES NO LIABILITY WHATSOEVER, INCLUDING WITHOUT LIMITATION, INDIRECT, CONSEQUENTIAL, SPECIAL, OR INCIDENTAL DAMAGES OR LOSS, INCLUDING WITHOUT LIMITATION, LOSS OF PROFITS, LOSS OF OPPORTUNITIES, BUSINESS INTERRUPTION AND LOSS OF DATA, AND (2) DISCLAIMS ANY AND ALL EXPRESS OR IMPLIED WARRANTIES AND CONDITIONS RELATED TO SALE, USE OF PRODUCT, OR INFORMATION, INCLUDING WARRANTIES OR CONDITIONS OF MERCHANTABILITY, FITNESS FOR A PARTICULAR PURPOSE, ACCURACY OF INFORMATION, OR NONINFRINGEMENT.**
- Do not use or otherwise make available Product or related software or technology for any military purposes, including without limitation, for the design, development, use, stockpiling or manufacturing of nuclear, chemical, or biological weapons or missile technology products (mass destruction weapons). Product and related software and technology may be controlled under the applicable export laws and regulations including, without limitation, the Japanese Foreign Exchange and Foreign Trade Law and the U.S. Export Administration Regulations. Export and re-export of Product or related software or technology are strictly prohibited except in compliance with all applicable export laws and regulations.
- Please contact your TOSHIBA sales representative for details as to environmental matters such as the RoHS compatibility of Product. Please use Product in compliance with all applicable laws and regulations that regulate the inclusion or use of controlled substances, including without limitation, the EU RoHS Directive. **TOSHIBA ASSUMES NO LIABILITY FOR DAMAGES OR LOSSES OCCURRING AS A RESULT OF NONCOMPLIANCE WITH APPLICABLE LAWS AND REGULATIONS.**

Toshiba Electronic Devices & Storage Corporation

<https://toshiba.semicon-storage.com/>