

Intelligent Power Device

TPD4164K

High Voltage Monolithic Silicon Power IC

1. Description

The TPD4164K is a DC brush less motor driver using high voltage PWM control. It is fabricated by high voltage SOI process. It is three-shunt resistor circuit for current sensing. It contains level shift high-side driver, low-side driver, IGBT outputs, FRDs and protective functions for over-current circuit and under voltage protection circuits and thermal shutdown circuit. It is easy to control a DC brush less motor by just putting logic inputs from a MCU or motor controller to the TPD4164K.

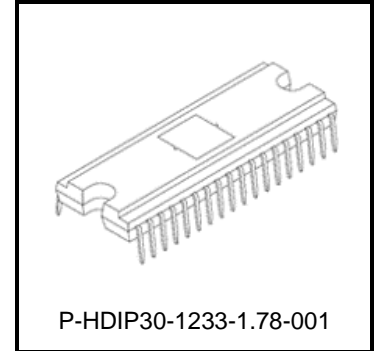

Weight: 2.59 g (typ.)

2. Applications

DC brushless motor driver IC

3. Features

- High voltage power side and low voltage signal side terminal are separated.
- It is the best for current sensing in three shunt resistance.
- Bootstrap circuit gives simple high-side supply.
- Bootstrap diodes are built in.
- A dead time can be set as a minimum of 1 μ s, and it is suitable for a Sine-wave from drive.
- 3-phase bridge output using IGBTs.
- Included over-current and under-voltage protection, shutdown function controlled by SD pin, and thermal shutdown.
- The regulator of 5 V (typ.) is built in.
- The package is a DIP type with 30 pin.

Start of commercial production
2023-05

4. Block Diagram

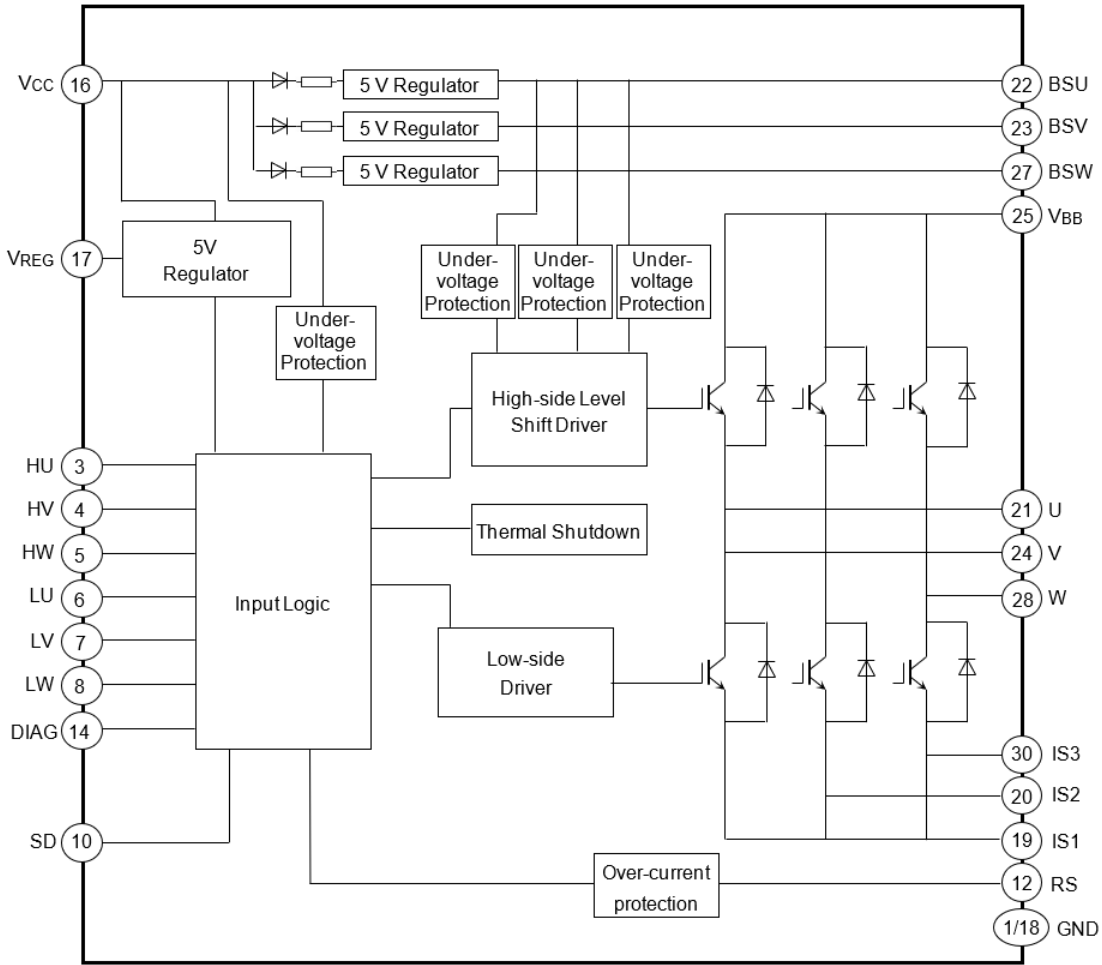

Figure 4.1 Block Diagram

5. Pin Assignments

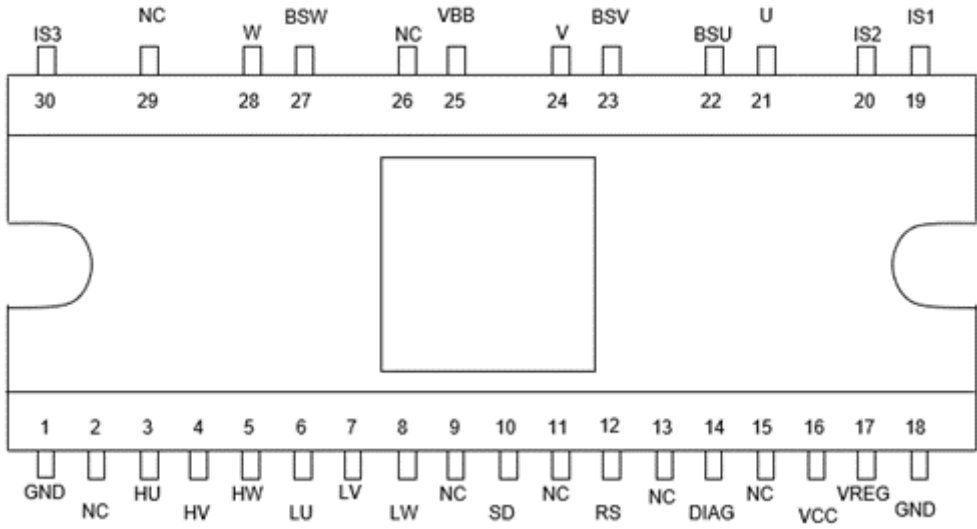

Figure 5.1 Pin Assignments

Marking

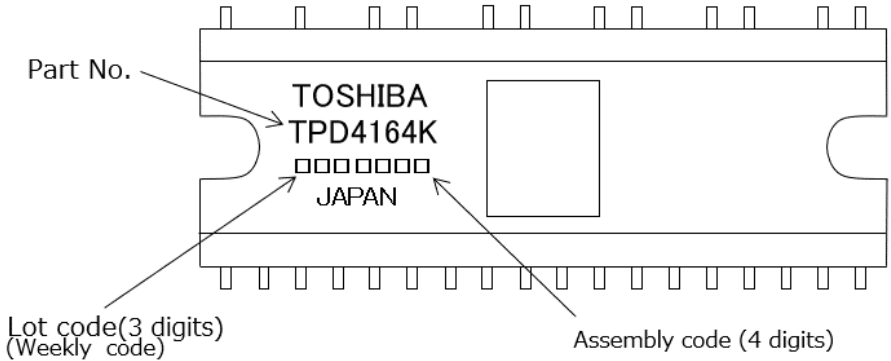

Figure 5.2 Marking

6. Pin Description

Table 6.1 Pin Description

Pin No.	Symbol	Pin Description
1	GND	Ground pin.
2	NC	Unused pin, which is not connected to the chip internally.
3	HU	The control terminal of IGBT by the high side of U. It turns off less than 1.5 V. It turns on more than 2.5 V.
4	HV	The control terminal of IGBT by the high side of V. It turns off less than 1.5 V. It turns on more than 2.5 V.
5	HW	The control terminal of IGBT by the high side of W. It turns off less than 1.5 V. It turns on more than 2.5 V.
6	LU	The control terminal of IGBT by the low side of U. It turns off less than 1.5 V. It turns on more than 2.5 V.
7	LV	The control terminal of IGBT by the low side of V. It turns off less than 1.5 V. It turns on more than 2.5 V.
8	LW	The control terminal of IGBT by the low side of W. It turns off less than 1.5 V. It turns on more than 2.5 V.
9	NC	Unused pin, which is not connected to the chip internally.
10	SD	Input pin of external protection. ("L" active, It doesn't have hysteresis.)
11	NC	Unused pin, which is not connected to the chip internally.
12	RS	Over current detection pin.
13	NC	Unused pin, which is not connected to the chip internally.
14	DIAG	With the diagnostic output terminal of open drain, a pull-up is carried out by resistance. It turns on at the time of unusual.
15	NC	Unused pin, which is not connected to the chip internally.
16	V _{CC}	Control power supply pin. (15 V typ.)
17	V _{REG}	5 V regulator output pin.
18	GND	Ground pin.
19	IS1	U-phase IGBT emitter and FRD anode pin.
20	IS2	V-phase IGBT emitter and FRD anode pin.
21	U	U-phase output pin.
22	BSU	U-phase bootstrap capacitor connecting pin.
23	BSV	V-phase bootstrap capacitor connecting pin.
24	V	V-phase output pin.
25	V _{BB}	High-voltage power supply input pin.
26	NC	Unused pin, which is not connected to the chip internally.
27	BSW	W-phase bootstrap capacitor connecting pin.
28	W	W-phase output pin.
29	NC	Unused pin, which is not connected to the chip internally.
30	IS3	W-phase IGBT emitter and FRD anode pin.

Equivalent circuit of input and output pins

HU, HV, HW, LU, LV, LW input pins

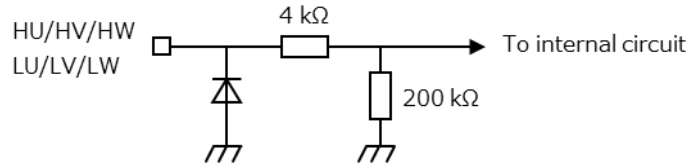

Figure 6.1 Equivalent circuit (1)

SD input pin

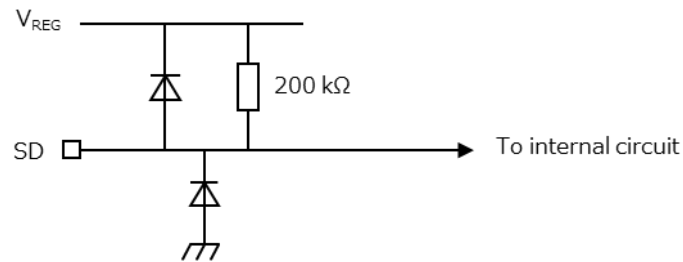

Figure 6.2 Equivalent circuit (2)

RS input pin

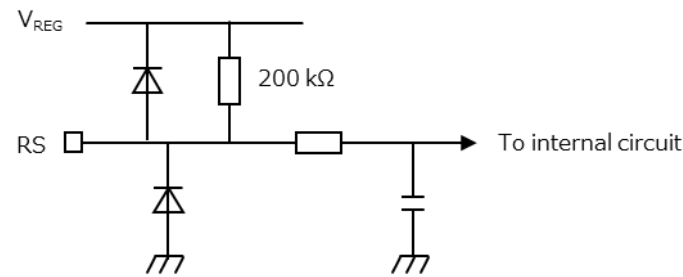

Figure 6.3 Equivalent circuit (3)

DIAG output pin

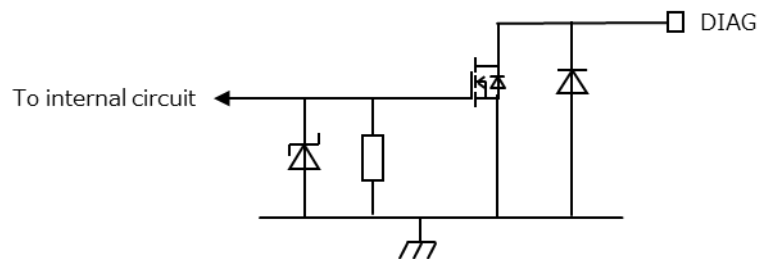

Figure 6.4 Equivalent circuit (4)

7. Functional Description

7.1. Basic Operation

7.1.1. Timing Chart

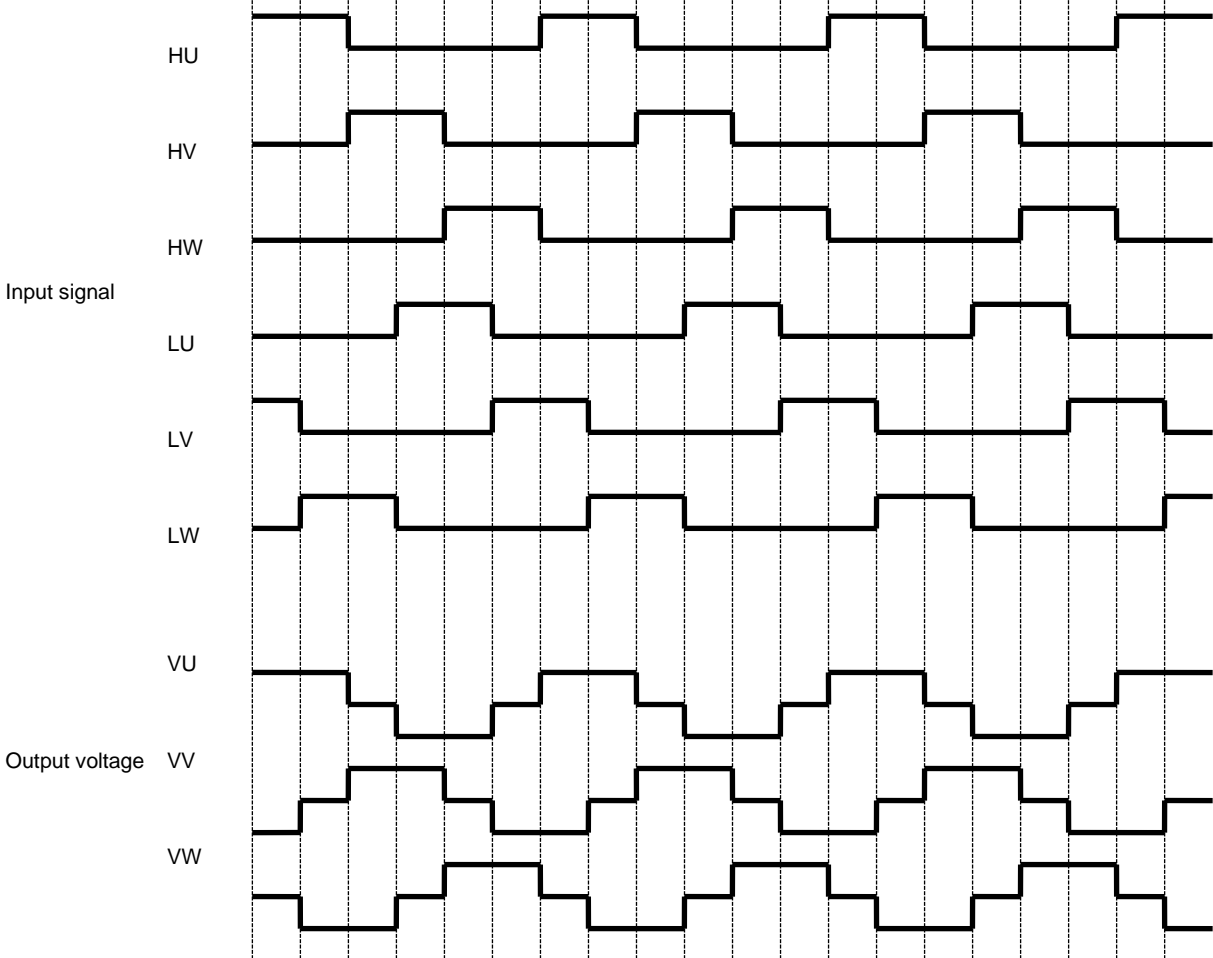

Figure 7.1.1 Timing Chart

7.1.2. Truth Table

Table 7.1.2 Truth Table

Mode	Input							High side			Low side			DIAG
	HU	HV	HW	LU	LV	LW	SD	U phase	V phase	W phase	U phase	V phase	W phase	
Normal	H	L	L	L	H	L	H	ON	OFF	OFF	OFF	ON	OFF	OFF
	H	L	L	L	L	H	H	ON	OFF	OFF	OFF	OFF	ON	OFF
	L	H	L	L	L	H	H	OFF	ON	OFF	OFF	OFF	ON	OFF
	L	H	L	H	L	L	H	OFF	ON	OFF	ON	OFF	OFF	OFF
	L	L	H	H	L	L	H	OFF	OFF	ON	ON	OFF	OFF	OFF
	L	L	H	L	H	L	H	OFF	OFF	ON	OFF	ON	OFF	OFF
Over-current	H	L	L	L	H	L	H	OFF	OFF	OFF	OFF	OFF	OFF	ON
	H	L	L	L	L	H	H	OFF	OFF	OFF	OFF	OFF	OFF	ON
	L	H	L	L	L	H	H	OFF	OFF	OFF	OFF	OFF	OFF	ON
	L	H	L	H	L	L	H	OFF	OFF	OFF	OFF	OFF	OFF	ON
	L	L	H	H	L	L	H	OFF	OFF	OFF	OFF	OFF	OFF	ON
	L	L	H	L	H	L	H	OFF	OFF	OFF	OFF	OFF	OFF	ON
Thermal shutdown	H	L	L	L	H	L	H	OFF	OFF	OFF	OFF	OFF	OFF	ON
	H	L	L	L	L	H	H	OFF	OFF	OFF	OFF	OFF	OFF	ON
	L	H	L	L	L	H	H	OFF	OFF	OFF	OFF	OFF	OFF	ON
	L	H	L	H	L	L	H	OFF	OFF	OFF	OFF	OFF	OFF	ON
	L	L	H	H	L	L	H	OFF	OFF	OFF	OFF	OFF	OFF	ON
	L	L	H	L	H	L	H	OFF	OFF	OFF	OFF	OFF	OFF	ON
Vcc Under-voltage	H	L	L	L	H	L	H	OFF	OFF	OFF	OFF	OFF	OFF	ON
	H	L	L	L	L	H	H	OFF	OFF	OFF	OFF	OFF	OFF	ON
	L	H	L	L	L	H	H	OFF	OFF	OFF	OFF	OFF	OFF	ON
	L	H	L	H	L	L	H	OFF	OFF	OFF	OFF	OFF	OFF	ON
	L	L	H	H	L	L	H	OFF	OFF	OFF	OFF	OFF	OFF	ON
	L	L	H	L	H	L	H	OFF	OFF	OFF	OFF	OFF	OFF	ON
V _{BS} Under-voltage	H	L	L	L	H	L	H	OFF	OFF	OFF	OFF	ON	OFF	OFF
	H	L	L	L	L	H	H	OFF	OFF	OFF	OFF	OFF	ON	OFF
	L	H	L	L	L	H	H	OFF	OFF	OFF	OFF	OFF	ON	OFF
	L	H	L	H	L	L	H	OFF	OFF	OFF	ON	OFF	OFF	OFF
	L	L	H	H	L	L	H	OFF	OFF	OFF	ON	OFF	OFF	OFF
	L	L	H	L	H	L	H	OFF	OFF	OFF	OFF	ON	OFF	OFF
Irregular (Note)	H	L	L	H	L	L	H	OFF	OFF	OFF	OFF	OFF	OFF	OFF
	L	H	L	L	H	L	H	OFF	OFF	OFF	OFF	OFF	OFF	OFF
	L	L	H	L	L	H	H	OFF	OFF	OFF	OFF	OFF	OFF	OFF
SD	X	X	X	X	X	X	L	OFF	OFF	OFF	OFF	OFF	OFF	ON

X: Don't care

Note: Each phases of U, V and W turns OFF when the control signals of both high side and low side are "H" at the same time.

(HU = "H" and LU = "H", HV = "H" and LV = "H", or HW = "H" and LW = "H")

7.2. Description of Protection Function

- (1) Under voltage protection
This product incorporates under voltage protection circuits to prevent the IGBT from operating in unsaturated mode when the VCC voltage or the VBS voltage drops.
When the VCC power supply falls to this product internal setting VCCUVD (=11 V typ.), all IGBT outputs shut down regardless of the input. This protection function has hysteresis. When the VCC power supply reaches 0.5 V higher than the shutdown voltage (VCCUVR (=11.5 V typ.)), this product is automatically restored and the IGBT is turned on again by the input. DIAG output is reversed at the time of VCC under-voltage protection. When the VCC power supply is less than 7 V, DIAG output isn't sometimes reversed. When the VBS supply voltage drops VBSUVD (=3 V typ.), the high-side IGBT output shuts down. When the VBS supply voltage reaches 0.5 V higher than the shutdown voltage (VBSUVR (=3.5V typ.)), the IGBT is turned on again by the input signal.
- (2) Over-current protection
This product incorporates a over-current protection circuit to protect itself against over-current at startup or when a motor is locked. This protection function detects voltage generated in the current detection resistor connected to the RS pin. When this voltage exceeds VR (=0.5 V typ.), the IGBT output, which is on, temporarily shuts down after a delay time, preventing any additional current from flowing to this product. The next all "L" signal releases the shutdown state.
- (3) Thermal shutdown
This product incorporates a thermal shutdown circuit to protect itself against the abnormal state when its temperature rises excessively.
When the temperature of this chip rises to the internal setting TSD due to external causes or internal heat generation, all IGBT outputs shut down regardless of the input. This protection function has hysteresis ΔTSD (= 50°C typ.). When the chip temperature falls to $TSD - \Delta TSD$, the chip is automatically restored and the IGBT is turned on again by the input.
Because the chip contains just one temperature detection location, when the chip heats up due to the IGBT, for example, the differences in distance from the detection location in the IGBT (the source of the heat) cause differences in the time taken for shutdown to occur. Therefore, the temperature of the chip may rise higher than the thermal shutdown temperature when the circuit started to operate.
- (4) SD function
SD pin is the input signal pin to shut down the internal output IGBT. Output of all IGBT is shut down after delay times (2 μ s (typ.)) when "L" signal is input to the SD pin from external circuit (MCU etc.). It is possible to shut down IC when overcurrent and others is detected by external circuit. Shut down state is released by all of IC input signal "L". At open state of SD pin, shut down function can not operate.

8. Absolute Maximum Ratings

Table 8.1 Absolute Maximum Ratings
($T_a = 25^{\circ}\text{C}$ unless otherwise specified)

Characteristics	Symbol	Rating	Unit
Power supply voltage	V_{BB}	600	V
	V_{CC}	20	V
Output current (DC)	I_{out}	2	A
Output current (pulse 1ms)	I_{outp}	3	A
Bootstrap pin voltage (Note1)	V_{BSX}	600	V
	V_{BSX-X}	- 0.5 to 6	V
Input voltage (Note2)	V_{IN}	- 0.5 to 6	V
V_{REG} current	I_{REG}	50	mA
DIAG voltage	V_{DIAG}	20	V
DIAG current	I_{DIAG}	20	mA
SD pin voltage	V_{SD}	- 0.5 to $V_{REG} + 0.5$	V
RS pin voltage	V_{RS}	- 0.5 to $V_{REG} + 0.5$	V
IS pin voltage (Note3)	V_{IS}	± 0.7	V
Power dissipation (IGBT 1-phase ($T_c = 25^{\circ}\text{C}$))	$P_{C(IGBT)}$	27	W
Power dissipation (FRD 1-phase ($T_c = 25^{\circ}\text{C}$))	$P_{C(FRD)}$	9	W
Operating junction temperature	T_{jopr}	- 40 to 135	$^{\circ}\text{C}$
Junction temperature	T_j	150	$^{\circ}\text{C}$
Storage temperature	T_{stg}	- 55 to 150	$^{\circ}\text{C}$

Note1: V_{BSX-X} : BSU-U, BSV-V, BSW-W

Note2: V_{IN} : HU, HV, HW, LU, LV, LW

Note3: Except for the peak voltage occurred in switching outputs including within the delay time of over current protection.

The absolute maximum ratings of a semiconductor device are a set of specified parameter values, which must not be exceeded during operation, even for an instant.

If any of these rating would be exceeded during operation, the device electrical characteristics may be irreparably altered and the reliability and lifetime of the device can no longer be guaranteed. Moreover, these operations with exceeded ratings may cause break down, damage, and/or degradation to any other equipment. Applications using the device should be designed such that each maximum rating will never be exceeded in any operating conditions.

Using continuously under heavy loads (e.g. the application of high temperature/current/voltage and the significant change in temperature, etc.) may cause this product to decrease in the reliability significantly even if the operating conditions (i.e. operating temperature/current/voltage, etc.) are within the absolute maximum ratings and the operating ranges.

Please design the appropriate reliability upon reviewing the Toshiba Semiconductor Reliability Handbook ("Handling Precautions"/"Derating Concept and Methods") and individual reliability data (i.e. reliability test report and estimated failure rate, etc).

9. Operating Ranges

Table 9.1 Operating Ranges ($T_a = 25^\circ\text{C}$ unless otherwise specified)

Characteristics	Symbol	Test Condition	Min	Typ.	Max	Unit
Operating power supply voltage	V_{BB}	—	50	280	450	V
	V_{CC}	—	13.5	15	16.5	

10. Electrical Characteristics

Table 10.1 Electrical Characteristics ($T_a = 25^\circ\text{C}$ unless otherwise specified)

Characteristics	Symbol	Test Condition	Min	Typ.	Max	Unit
Current dissipation	I_{BB}	$V_{BB} = 450\text{ V}$	—	—	0.5	mA
	I_{CC}	$V_{CC} = 15\text{ V}$	—	0.8	1.5	
Bootstrap Current dissipation	$I_{BS}(\text{ON})$	$V_{BS} = 5\text{ V}$, high side ON	—	90	150	μA
	$I_{BS}(\text{OFF})$	$V_{BS} = 5\text{ V}$, high side OFF	—	80	140	
Input voltage	V_{IH}	$V_{IN} = \text{“H”}$, $V_{CC} = 15\text{ V}$	2.5	—	—	V
	V_{IL}	$V_{IN} = \text{“L”}$, $V_{CC} = 15\text{ V}$	—	—	1.5	
Input current	I_{IH}	$V_{IN} = 5\text{ V}$	—	—	50	μA
	I_{IL}	$V_{IN} = 0\text{ V}$	—	—	10	
Output saturation voltage	V_{CEsatH}	$V_{CC} = 15\text{ V}$, $I_C = 1\text{ A}$, high side	—	3.0	3.7	V
	V_{CEsatL}	$V_{CC} = 15\text{ V}$, $I_C = 1\text{ A}$, low side	—	3.0	3.7	
FRD forward voltage	V_{FH}	$I_F = 1\text{ A}$, high side	—	2.5	3.2	V
	V_{FL}	$I_F = 1\text{ A}$, low side	—	2.5	3.2	
Regulator voltage	V_{REG}	$V_{CC} = 15\text{ V}$, $I_{REG} = 30\text{ mA}$	4.5	5	5.5	V
Over current protection voltage	V_R	—	0.46	0.5	0.54	V
Over current protection delay time	D_t	—	—	2	3	μs
Thermal shutdown temperature	T_{SD}	$V_{CC} = 15\text{ V}$	135	—	165	$^\circ\text{C}$
Thermal shutdown hysteresis	ΔT_{SD}	$V_{CC} = 15\text{ V}$	—	50	—	$^\circ\text{C}$
V_{CC} under voltage protection	V_{CCUVD}	—	10	11	12	V
V_{CC} under voltage protection recovery	V_{CCUVR}	—	10.5	11.5	12.5	V
V_{BS} under voltage protection	V_{BSUVD}	—	2	3	4	V
V_{BS} under voltage protection recovery	V_{BSUVR}	—	2.5	3.5	4.5	V
DIAG saturation voltage	$V_{DIAGsat}$	$I_{DIAG} = 5\text{ mA}$	—	—	0.5	V
Minimum operating pulse width	PW_{min}	$V_{BB} = 280\text{ V}$, $V_{CC} = 15\text{ V}$	0.8	—	—	μs
SD Input voltage	V_{SD}	$V_{CC} = 15\text{ V}$	—	2.5	—	V
Output on delay time	t_{on}	$V_{BB} = 280\text{ V}$, $V_{CC} = 15\text{ V}$, $I_C = 1\text{ A}$	—	1.0	1.5	μs
Output off delay time	t_{off}	$V_{BB} = 280\text{ V}$, $V_{CC} = 15\text{ V}$, $I_C = 1\text{ A}$	—	1.2	1.7	μs
Dead time	t_{dead}	$V_{BB} = 280\text{ V}$, $V_{CC} = 15\text{ V}$, $I_C = 1\text{ A}$	1	—	—	μs
FRD reverse recovery time	t_{rr}	$V_{BB} = 280\text{ V}$, $V_{CC} = 15\text{ V}$, $I_C = 1\text{ A}$	—	200	—	ns

11. Safe Operating Area

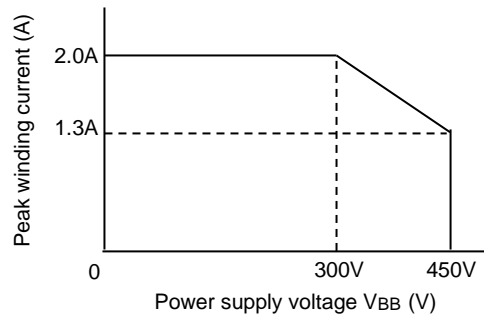

Figure 11.1 SOA at $T_j = 135\text{ }^\circ\text{C}$

12. Application Circuit Example

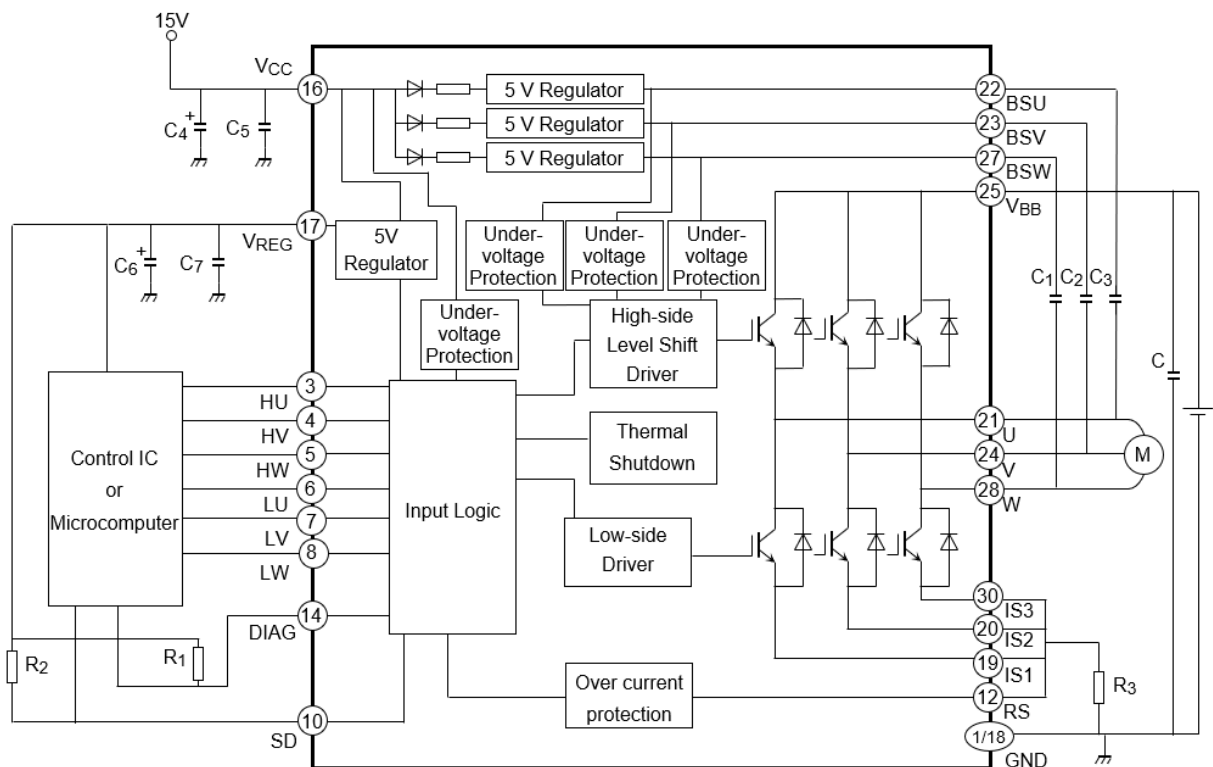

Figure 12.1 Application Circuit Example

Typical external parts are shown in the following table.

Table 12.1 Typical external parts

Part	Typical	Purpose	Remarks
C ₁ , C ₂ , C ₃	25 V/2.2 μF	Bootstrap capacitor	(Note 1)
C ₄	25 V/10 μF	V _{CC} power supply stability	(Note 2)
C ₅	25 V/0.1 μF	V _{CC} for surge absorber	(Note 2)
C ₆	25 V/10 μF	V _{REG} power supply stability	(Note 2)
C ₇	25 V/0.1 μF	V _{REG} for surge absorber	(Note 2)
R ₁	5.1 kΩ	DIAG pin pull-up resistor	(Note 3)
R ₂	10 kΩ	SD pin pull-up resistor	-
R ₃	0.35 Ω ± 1 % (1 W)	Over current detection	(Note 4)

Note 1: The required bootstrap capacitance value varies according to the motor drive conditions. The capacitor is biased by 5V(typ.) and must be sufficiently derated for it.

Note 2: When using this product, adjustment is required in accordance with the use environment. When mounting, place as close to the base of this product leads as possible to improve the ripple and noise elimination.

Note 3: The DIAG pin is open drain. If not using the DIAG pin, connect to the GND.

Note 4: The following formula shows the detection current: $I_O = V_R / R_3$ (For $V_R = 0.5$ V typ.)

13. Handling precautions

- (1) Please control the input signal in the state to which the V_{CC} voltage is steady. Both of the order of the V_{BB} power supply and the V_{CC} power supply are not cared about either. Note that if the power supply is switched off as described above, this product may be destroyed if the current regeneration route to the V_{BB} power supply is blocked when the V_{BB} line is disconnected by a relay or similar while the motor is still running.
- (2) Over voltage caused by a surge voltage over the absolute maximum ratings may destroy the circuit. Accordingly, be careful of handling the IC or of surge voltage in its application environment.

14. Package Information

14.1. Package Dimensions

P-HDIP30-1233-1.78-001

Unit: mm

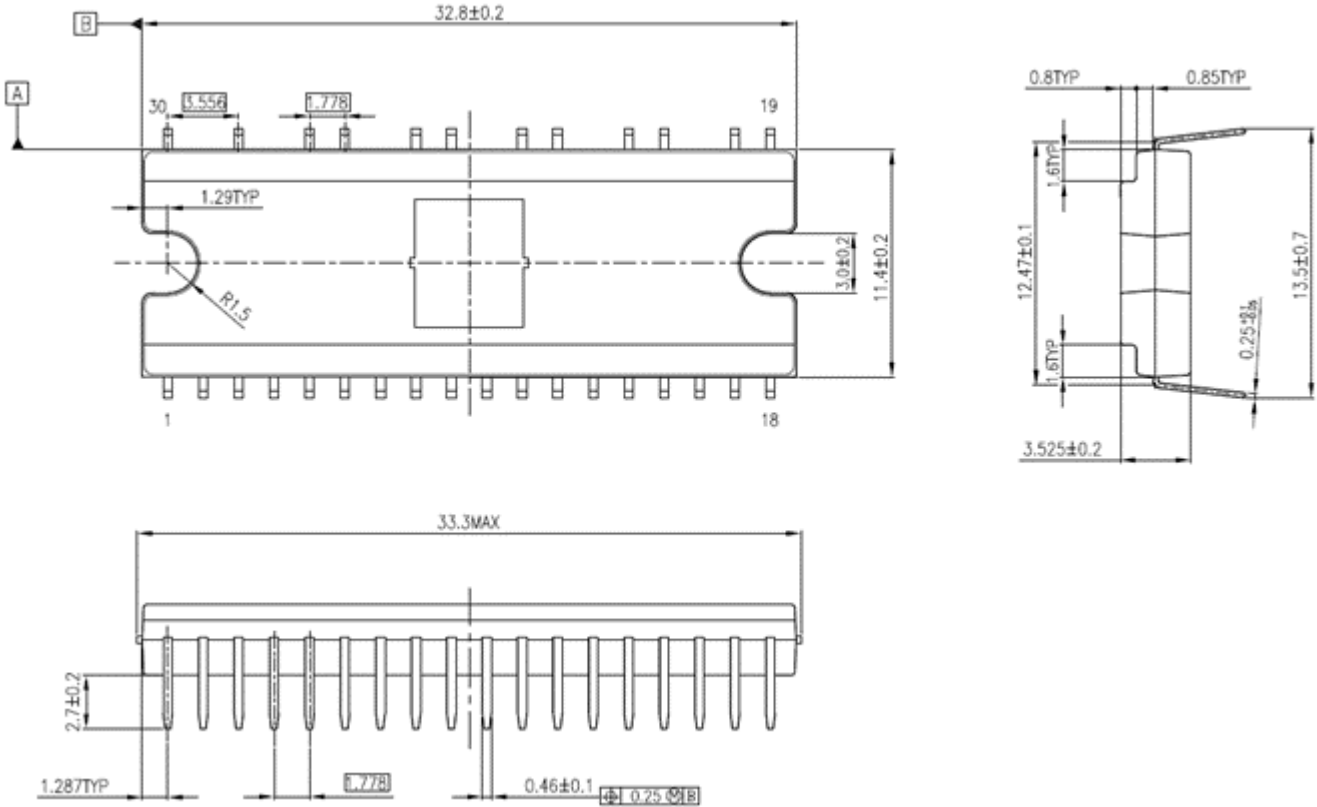

Weight: 2.59 g (typ.)

Figure 14.1 Package Dimensions

RESTRICTIONS ON PRODUCT USE

Toshiba Corporation and its subsidiaries and affiliates are collectively referred to as "TOSHIBA". Hardware, software and systems described in this document are collectively referred to as "Product".

- TOSHIBA reserves the right to make changes to the information in this document and related Product without notice.
- This document and any information herein may not be reproduced without prior written permission from TOSHIBA. Even with TOSHIBA's written permission, reproduction is permissible only if reproduction is without alteration/omission.
- Though TOSHIBA works continually to improve Product's quality and reliability, Product can malfunction or fail. Customers are responsible for complying with safety standards and for providing adequate designs and safeguards for their hardware, software and systems which minimize risk and avoid situations in which a malfunction or failure of Product could cause loss of human life, bodily injury or damage to property, including data loss or corruption. Before customers use the Product, create designs including the Product, or incorporate the Product into their own applications, customers must also refer to and comply with (a) the latest versions of all relevant TOSHIBA information, including without limitation, this document, the specifications, the data sheets and application notes for Product and the precautions and conditions set forth in the "TOSHIBA Semiconductor Reliability Handbook" and (b) the instructions for the application with which the Product will be used with or for. Customers are solely responsible for all aspects of their own product design or applications, including but not limited to (a) determining the appropriateness of the use of this Product in such design or applications; (b) evaluating and determining the applicability of any information contained in this document, or in charts, diagrams, programs, algorithms, sample application circuits, or any other referenced documents; and (c) validating all operating parameters for such designs and applications. **TOSHIBA ASSUMES NO LIABILITY FOR CUSTOMERS' PRODUCT DESIGN OR APPLICATIONS.**
- **PRODUCT IS NEITHER INTENDED NOR WARRANTED FOR USE IN EQUIPMENTS OR SYSTEMS THAT REQUIRE EXTRAORDINARILY HIGH LEVELS OF QUALITY AND/OR RELIABILITY, AND/OR A MALFUNCTION OR FAILURE OF WHICH MAY CAUSE LOSS OF HUMAN LIFE, BODILY INJURY, SERIOUS PROPERTY DAMAGE AND/OR SERIOUS PUBLIC IMPACT ("UNINTENDED USE").** Except for specific applications as expressly stated in this document, Unintended Use includes, without limitation, equipment used in nuclear facilities, equipment used in the aerospace industry, lifesaving and/or life supporting medical equipment, equipment used for automobiles, trains, ships and other transportation, traffic signaling equipment, equipment used to control combustions or explosions, safety devices, elevators and escalators, and devices related to power plant. **IF YOU USE PRODUCT FOR UNINTENDED USE, TOSHIBA ASSUMES NO LIABILITY FOR PRODUCT.** For details, please contact your TOSHIBA sales representative or contact us via our website.
- Do not disassemble, analyze, reverse-engineer, alter, modify, translate or copy Product, whether in whole or in part.
- Product shall not be used for or incorporated into any products or systems whose manufacture, use, or sale is prohibited under any applicable laws or regulations.
- The information contained herein is presented only as guidance for Product use. No responsibility is assumed by TOSHIBA for any infringement of patents or any other intellectual property rights of third parties that may result from the use of Product. No license to any intellectual property right is granted by this document, whether express or implied, by estoppel or otherwise.
- **ABSENT A WRITTEN SIGNED AGREEMENT, EXCEPT AS PROVIDED IN THE RELEVANT TERMS AND CONDITIONS OF SALE FOR PRODUCT, AND TO THE MAXIMUM EXTENT ALLOWABLE BY LAW, TOSHIBA (1) ASSUMES NO LIABILITY WHATSOEVER, INCLUDING WITHOUT LIMITATION, INDIRECT, CONSEQUENTIAL, SPECIAL, OR INCIDENTAL DAMAGES OR LOSS, INCLUDING WITHOUT LIMITATION, LOSS OF PROFITS, LOSS OF OPPORTUNITIES, BUSINESS INTERRUPTION AND LOSS OF DATA, AND (2) DISCLAIMS ANY AND ALL EXPRESS OR IMPLIED WARRANTIES AND CONDITIONS RELATED TO SALE, USE OF PRODUCT, OR INFORMATION, INCLUDING WARRANTIES OR CONDITIONS OF MERCHANTABILITY, FITNESS FOR A PARTICULAR PURPOSE, ACCURACY OF INFORMATION, OR NONINFRINGEMENT.**
- Do not use or otherwise make available Product or related software or technology for any military purposes, including without limitation, for the design, development, use, stockpiling or manufacturing of nuclear, chemical, or biological weapons or missile technology products (mass destruction weapons). Product and related software and technology may be controlled under the applicable export laws and regulations including, without limitation, the Japanese Foreign Exchange and Foreign Trade Law and the U.S. Export Administration Regulations. Export and re-export of Product or related software or technology are strictly prohibited except in compliance with all applicable export laws and regulations.
- Please contact your TOSHIBA sales representative for details as to environmental matters such as the RoHS compatibility of Product. Please use Product in compliance with all applicable laws and regulations that regulate the inclusion or use of controlled substances, including without limitation, the EU RoHS Directive. **TOSHIBA ASSUMES NO LIABILITY FOR DAMAGES OR LOSSES OCCURRING AS A RESULT OF NONCOMPLIANCE WITH APPLICABLE LAWS AND REGULATIONS.**

