

**Over Temperature Detection IC  
Thermoflagger™ Application Circuit  
(TCTH021BE version)**

# **Design Guide**

**RD225B-DGUIDE-02**

---

**Toshiba Electronic Devices & Storage Corporation**

## Table of Contents

<b>1. Introduction</b>	<b>3</b>
<b>2. Components Used</b>	<b>4</b>
2.1. Over Temperature Detection IC Thermoflagger™ TCTH021BE	4
2.1.1. Operation	5
2.2. N-ch MOSFET SSM3K35MFV	6
2.3. P-ch MOSFET SSM3J35AMFV	6
<b>3. Specifications and Block Diagram</b>	<b>7</b>
3.1. Specifications	7
<b>4. Circuit Design</b>	<b>8</b>
4.1. Circuit Diagram	8
4.1.1. PTC Thermistor Section	8
4.1.2. Over Temperature Detection IC	9
4.1.3. Alert Temperature Variation	9
4.1.4. LED Drive Circuit	10
4.1.5. Power Supply Input Circuit	11
4.1.6. Operation	11
<b>5. PCB Designs</b>	<b>11</b>
5.1. Component Layout Example	11

## 1. Introduction

This Design Guide describes the reference design (hereafter referred to as this design) of the Over Temperature Detection Circuit using the Over Temperature Detection IC Thermoflagger™. This design has a simple configuration which detects the rise of temperature above the set alert temperature.

This design uses an Over Temperature Detection IC Thermoflagger™ [TCTH021BE](#). MOSFETs [SSM3K35MFV](#) and [SSM3J35AMFV](#) are also used to drive LEDs.

## 2. Components Used

### 2.1. Over Temperature Detection IC Thermoflagger™ TCTH021BE

This design uses the over temperature detection IC Thermoflagger™ [TCTH021BE](#). TCTH021BE is used in conjunction with a PTC thermistor whose resistance changes with temperature.

TCTH021BE detects the change in resistance of PTC thermistor placed at the position where over temperature is desired to be detected, and it outputs FLAG signal when over temperature is detected i.e., when thermistor's temperature rises above its set alert temperature. Thus, helping in detecting over temperature in an electronic equipment. By connecting multiple PTC thermistors in series, over temperature can be detected at multiple points. Its package is the small-size industry standard SOT-553 (our package name: ESV) and it achieves a low current consumption of 11.3 μA (Typ.). Thermoflagger™ can be used to easily configure the over temperature detection system of the entire electronic equipment, and it contributes to miniaturization and low power dissipation.

The features of TCTH021BE are as follows.

#### Features

- PTCO output current  $I_{PTCO} = 10 \mu A$  (Typ.)
- High PTCO output current accuracy  $\pm 8 \%$  ( $V_{DD} = 3.3 V, 25 \text{ }^\circ C$ )
- Low current consumption  $I_{DD} = 11.3 \mu A$  (Typ.)
- FLAG signal output (PTCGOOD) : Open-drain type
- Standard package ESV (SOT-553) (1.6 mm x 1.6 mm x 0.55 mm)

#### Application Equipment

- Mobile equipment (e.g. Notebook PC)
- Home appliance
- Industry equipment, etc.

#### External View and Pin Arrangement (Top View)

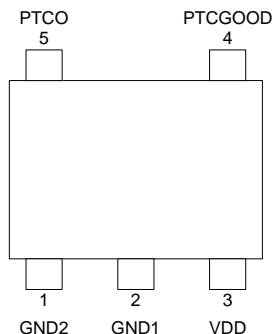

**2.1.1. Operation**

Fig. 2.1 and Fig. 2.2 show the internal circuit diagram of Thermoflagger™ TCTH021BE during normal temperature and over temperature respectively. The internal circuit sections listed below are also shown in the following figures.

- (1) Open Drain Output Section
- (2) Comparator Section
- (3) Reference Voltage (0.5 V) Section
- (4) Constant Current Source (10 μA) Section

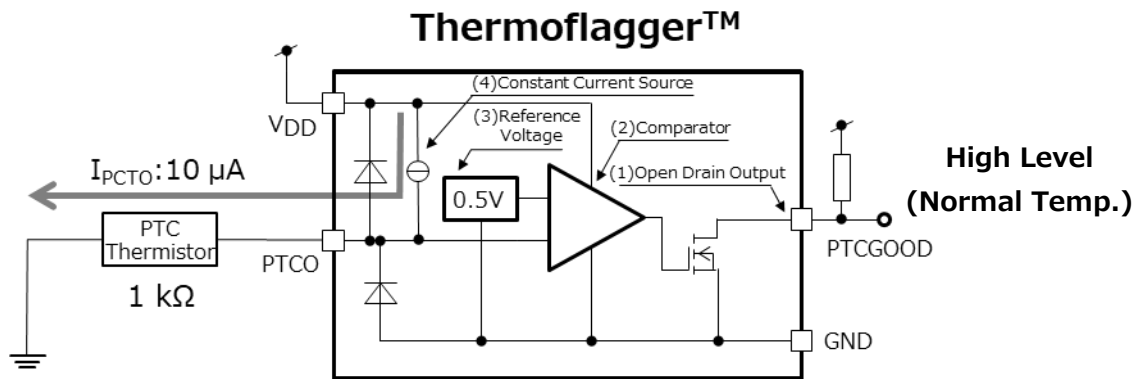

**Fig. 2.1 Internal Circuit Diagram (during Normal Temperature)**

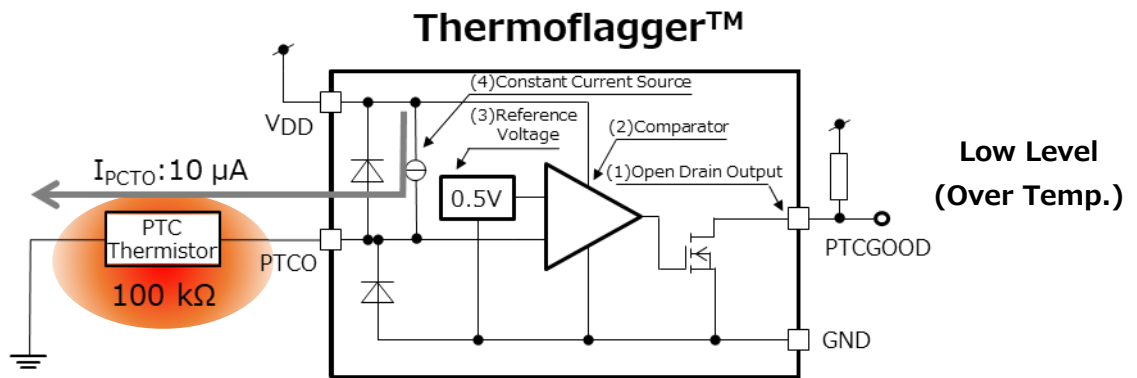

**Fig. 2.2 Internal Circuit Diagram (during Over Temperature)**

The over temperature detection IC Thermoflagger™ TCTH021BE detects over temperature and is used by connecting a PTC thermistor to PTCO pin. A constant current of 10 μA (Typ.)  $I_{PCTO}$  flows from PTCO pin to PTC thermistor. Thus:

$$\text{Voltage of PTCO pin} = (\text{resistance of PTC thermistor}) \times 10 \mu\text{A} \quad \dots (1)$$

PTC thermistor has the property that its resistance rises rapidly when the temperature exceeds a certain temperature. TCTH021BE detects the over temperature when the voltage at PTCO pin (sensing voltage) becomes more than 0.5 V (Typ.) detection voltage ( $V_{DET}$ ) which is the reference voltage of the internal comparator. And this happens when the resistance of PTC thermistor becomes 50 kΩ (Typ.) or more, since the current flowing through the thermistor is always 10 μA

( $I_{PTCO}$ ). TCTH021BE outputs FLAG signal from PTCGOOD pin according to the voltage at PTCO pin. When a voltage equal to or greater than the detection voltage  $V_{DET}$  appears on PTCO pin, over temperature is detected, and "Low" output is generated. When the voltage is lower than  $V_{DET}$ , a "High" output is generated.

Therefore, when the resistance of PTC thermistor at normal temperature is 1 k $\Omega$ , (Fig. 2.1) PTCO pin voltage is approximately 10 mV from equation (1), FLAG signal becomes "High". And when the temperature rises and the resistance of PTC thermistor becomes 100 k $\Omega$  (Fig. 2.2), the voltage at PTCO pin becomes 1 V and FLAG signal becomes "Low".

## 2.2. N-ch MOSFET SSM3K35MFV

This design uses N-ch MOSFET [SSM3K35MFV](#) in LED drive circuit. The features of SSM3K35MFV are as follows.

### Features

- Compact package (VESM, SOT-723:1.2 x 1.2 x 0.5 mm)
- Low on-resistance  $R_{DS(ON)} = 8.0 \Omega$  (Max.) @ $V_{GS} = 1.5 V$   
 $R_{DS(ON)} = 4.0 \Omega$  (Max.) @ $V_{GS} = 2.5 V$

## 2.3. P-ch MOSFET SSM3J35AMFV

This design uses P-ch MOSFET [SSM3J35AMFV](#) in LED drive circuit. The features of SSM3J35AMFV are as follows.

### Features

- Compact package (VESM, SOT-723:1.2 x 1.2 x 0.5 mm)
- Low on-resistance  $R_{DS(ON)} = 4.0 \Omega$  (Max.) @ $V_{GS} = -1.5 V$   
 $R_{DS(ON)} = 2.1 \Omega$  (Max.) @ $V_{GS} = -2.5 V$

## 3. Specifications and Block Diagram

### 3.1. Specifications

Table 3.1 lists the main specifications of this circuit, and Fig. 3.1 shows the block diagram.

**Table 3.1 Circuit Specifications**

Circuit Name	Thermoflagger™	Onboard Sensor	Power Supply	Operation
BE1	TCTH021BE (Open-drain type)	PTC thermistor	USB Type-C®	Red LED turns ON if the temperature of either PTC thermistor exceeds its alert temperature.

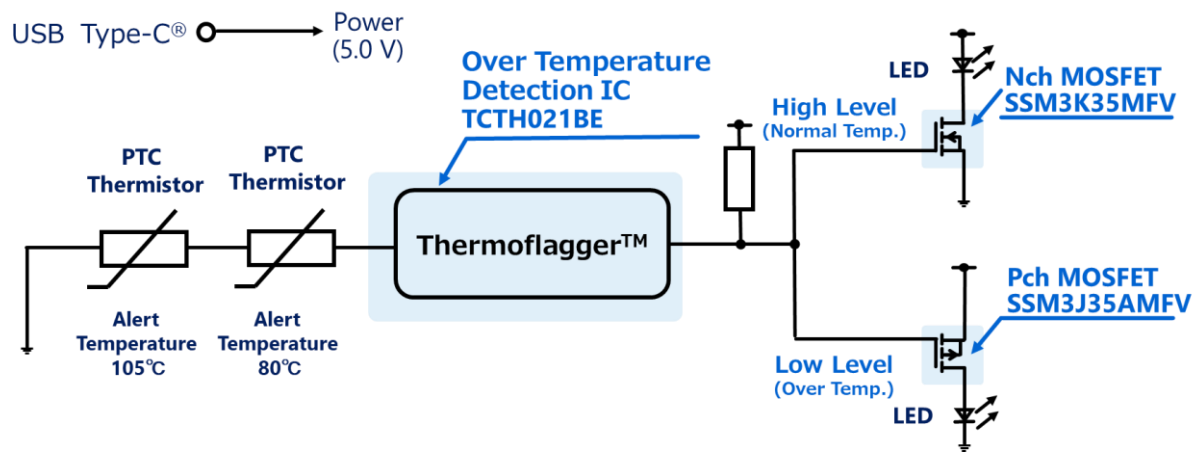

**Fig. 3.1 Block Diagram**

## 4. Circuit Design

### 4.1. Circuit Diagram

Fig. 4.1 shows the circuit diagram.

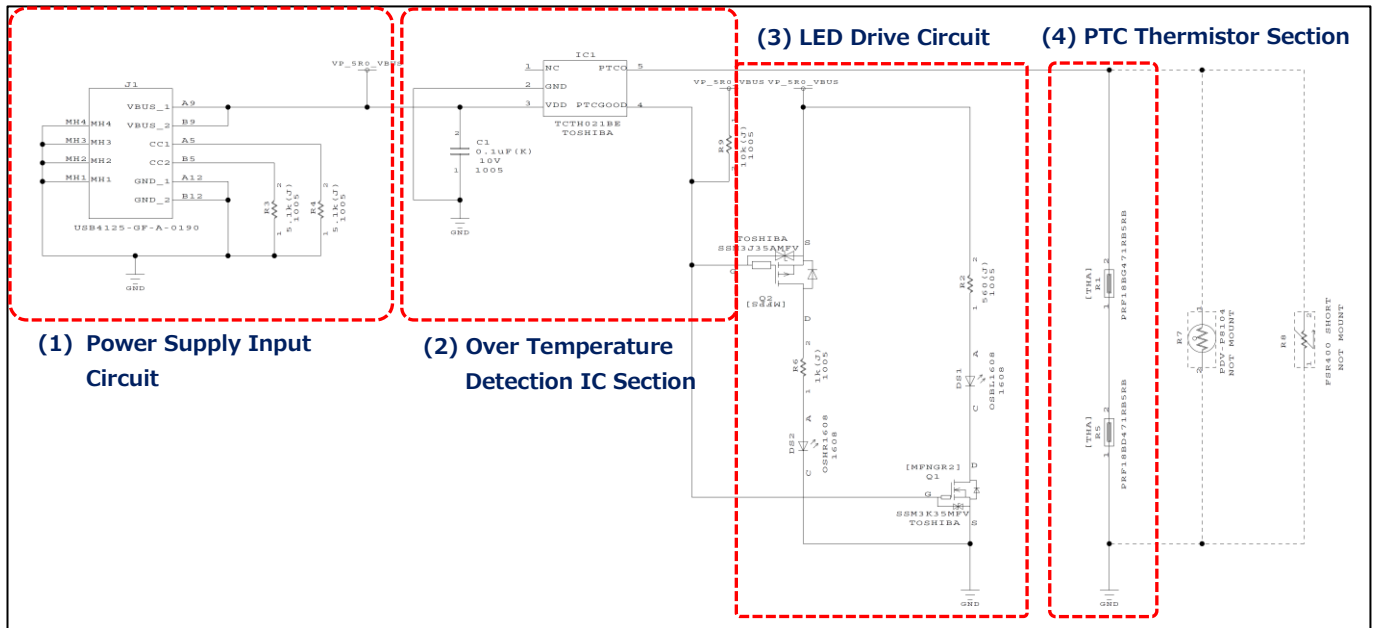

Fig. 4.1 Schematic

#### 4.1.1. PTC Thermistor Section

In this design, a circuit to detect over temperature abnormality is designed which in this design is the rise of temperature above approximately 80 °C and approximately 105 °C. In this design, over temperature detection happens when the resistance value between PTCO pin and GND becomes 50 kΩ or more. So, two thermistors with different resistance-temperature characteristics are connected in series between PTCO and GND in order to detect different temperatures which are approximately 80 °C and 105 °C. The resistance of PTC thermistor PRF18BG471RB5RB (R1, Murata) and PRF18BD471RB5RB (R5, Murata) becomes 50 kΩ at approximately 80 °C and 105 °C respectively.

Fig. 4.2 and Fig. 4.3 show the thermal characteristics of PTC thermistor PRF18BG471RB5RB and PRF18BD471RB5RB respectively. PTC thermistors have the property that their resistance increases rapidly as the temperature rises. From these figures it can be seen that PRF18BG471RB5RB will detect an over temperature between approximately 72 °C and 86 °C, and PRF18BD471RB5RB will detect over temperature between approximately 104 °C and 116 °C, because at these temperatures their resistance become 50 kΩ.



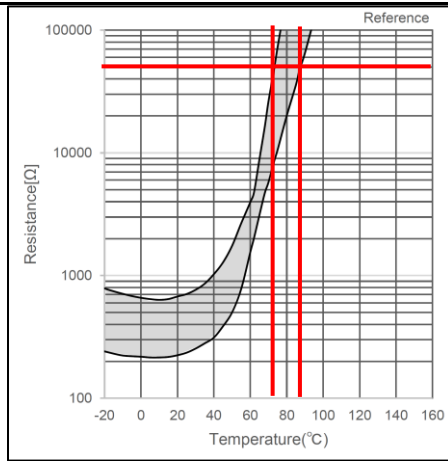

**Fig. 4.2 PRF18BG471RB5RB  
Resistance-Temperature  
Characteristic  
(Quoted from Murata Datasheet)**

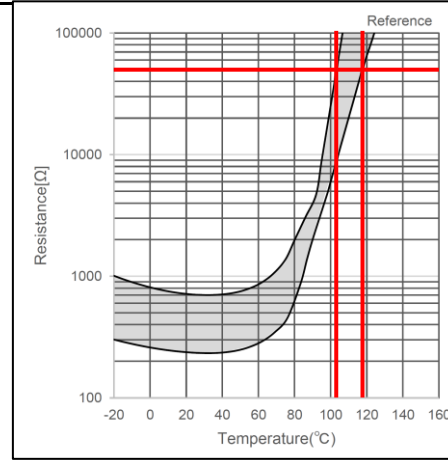

**Fig. 4.3 PRF18BD471RB5RB  
Resistance-Temperature  
Characteristic  
(Quoted from Murata Datasheet)**

### 4.1.2. Over Temperature Detection IC

This circuit is equipped with an over temperature detection IC Thermoflagger™ TCTH021BE (IC1). A constant-current  $I_{PTCO}$  of 10  $\mu\text{A}$  (Typ.) is output from PTCO pin of TCTH021BE, and a PTC thermistor is connected between this pin and GND. PTCGOOD output pin has an open-drain configuration and outputs the FLAG signal. When the voltage  $V_{PTCO}$  at PTCO pin exceeds the specified voltage  $V_{DET}$  (0.5 V (Typ.)), the FLAG output becomes Low, and when  $V_{PTCO}$  falls below  $V_{DET}$ , the FLAG output becomes high impedance. TCTH021BE's PTCGOOD pin is pulled up by 10 k $\Omega$  (R9) to 5 V, so when PTCGOOD pin is in the high-impedance state, FLAG signal output is High level of approximately 5 V.

### 4.1.3. Alert Temperature Variation

Table 4.1 shows the variations in  $I_{PTCO}$  and  $V_{DET}$  of TCTH021BE.

**Table 4.1 Properties of TCTH021BE ( $V_{DD} = 5.0\text{ V}$ ,  $V_{SS} = \text{GND}$ ,  $T_a = 25\text{ }^\circ\text{C}$ )**

Item	Symbol	Min.	Typ.	Max.	Unit
PTCO Output Current	$I_{PTCO}$	8.0	10.0	12.2	$\mu\text{A}$
Sensing Voltage	$V_{DET}$	0.42	0.50	0.58	V

Due to variations in  $I_{PTCO}$ ,  $V_{DET}$  of TCTH021BE, the resistance of PTC thermistor must be within the following limits. When designing, enough margin must be considered.

$$\frac{V_{DET}(\text{Min.})}{I_{PTCO}(\text{Max.})} < \text{Resistance of PTC thermistor at alert temperature} < \frac{V_{DET}(\text{Max.})}{I_{PTCO}(\text{Min.})}$$

$$= \frac{0.42\text{ V}}{12.2\ \mu\text{A}} < \text{Resistance of PTC thermistor at alert temperature} < \frac{0.58\text{ V}}{8\ \mu\text{A}}$$

$$= 34.4 \text{ k}\Omega < \text{Resistance of PTC thermistor at alert temperature} < 72.5 \text{ k}\Omega$$

Based on the above calculations and PTC thermistor specifications, this design detects over temperature abnormality when the temperature of PRF18BG471RB5RB (R1) is between approximately 71 °C and 90 °C (Fig. 4.4) and when the temperature of PRF18BD471RB5RB (R5) is between approximately 102 °C and 122 °C (Fig. 4.5).

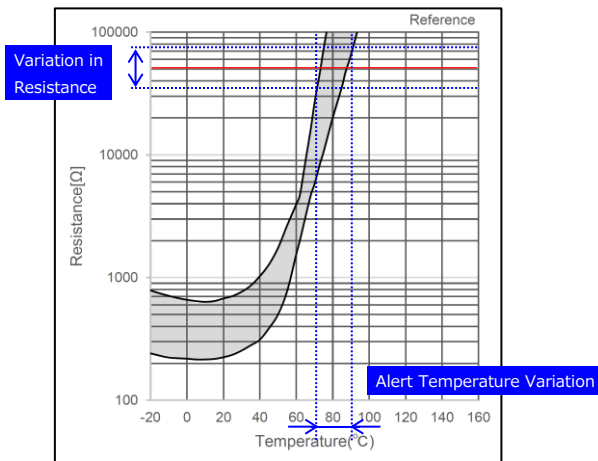

**Fig. 4.4 PRF18BG471RB5RB  
Resistance-Temperature  
Characteristic  
(Quoted from product specifications)**

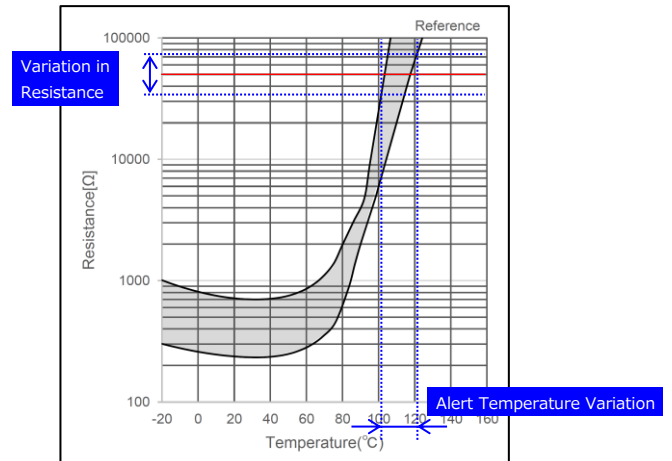

**Fig. 4.5 PRF18BD471RB5RB  
Resistance-Temperature  
Characteristic  
(Quoted from product specifications)**

### 4.1.4. LED Drive Circuit

LED drive circuit consists of a red LED (DS2) which is ON when FLAG signal is Low, a LED current limiting resistor R6, a high-side switch P-ch MOSFET (Q1) that drives the LED, a blue LED (DS1) which is ON when FLAG signal is High, a LED current limiting resistor R2, and a low-side switch N-ch MOSFET (Q2) that drives the LED.

In this circuit the power supply voltage is  $V_{DD}$ , forward current of LED is  $I_F$ , ON resistance of MOSFET is  $R_{DS(ON)}$  and the value of current limiting resistor is  $R$ , thus the forward current  $I_F$  flowing through LED is expressed by the following equation.

$$I_F = \frac{(V_{DD} - V_F)}{(R + R_{DS(ON)})} = \frac{5 - V_F}{R + R_{DS(ON)}}$$

The LED drive circuit of the red LED (DS2) is designed in order to have a forward current  $I_F$  of about 3 mA.

When FLAG output of Thermoflagger™ is Low,  $V_{GS}$  of MOSFET (Q2) becomes approximately -5 V, which turns on the MOSFET and the red LED lights up. At this time, the on-resistor  $R_{DS(ON)}$  is approximately 1.4  $\Omega$ , and since  $I_F = 3$  mA, and  $V_F = 2.2$  V, thus  $R \approx 930 \Omega$ . Therefore, the current limiting resistor R6 is set to 1 k $\Omega$ .

The LED drive circuit of the blue LED (DS1) is also designed in order to have a forward current  $I_F$  of about 3 mA.

When FLAG output of Thermoflagger™ is High,  $V_{GS}$  of MOSFET (Q1) becomes approximately 5 V, which turns on the MOSFET and the blue LED lights up. At this time, the on-resistor  $R_{DS(ON)}$  is approximately 3  $\Omega$ , and since  $I_F = 3$  mA, and  $V_F = 3.2$  V, thus  $R \approx 597$   $\Omega$ . Therefore, the current-limiting resistor R2 is set to 560  $\Omega$ .

#### 4.1.5. Power Supply Input Circuit

In this case, power is supplied by connecting a USB charger to USB Type-C® receptable (J1). In order to supply the power (VDD) to this circuit via J1, this circuit must be set as sink side, thus CC1 and CC2 pins of J1 are pulled down with 5.1 k $\Omega$  (R3, R4) according to the USB Type-C® configuration.

#### 4.1.6. Operation

[At room temperature]

The resistances of the two PTC thermistor R1, R5 are approximately 470  $\Omega$ . Since the constant current  $I_{PTCO}$  from PTCO pin of the over temperature detection IC Thermoflagger™ is 10  $\mu$ A, the voltage of PTCO pin  $V_{PTCO}$  is  $470 \Omega \times 2 \times 10 \mu A = 9.4$  mV and since it is lower than  $V_{DET}$ , the FLAG signal is High and the blue LED (DS1) is ON.

[When the temperature of PTC thermistor (R1) is approximately 80 °C or more]

When the temperature of PTC thermistor (R1) rises to approximately 80 °C, its resistance increases to approximately 50 k $\Omega$ . Therefore,  $V_{PTCO}$  becomes  $(50 \text{ k}\Omega + 470 \Omega) \times 10 \mu A \approx 0.5$  V, and since it is higher than  $V_{DET}$ , FLAG signal becomes Low and the red LED (DS2) turns on.

[When the temperature of PTC thermistor (R5) is approximately 105 °C or more]

When the temperature of PTC thermistor (R5) rises to approximately 105 °C, its resistance increases to approximately 50 k $\Omega$ . Therefore,  $V_{PTCO}$  becomes more than  $V_{DET}$ , thus FLAG signal becomes Low and the red LED (DS2) turns on.

When two or more PTC thermistors are connected to PTCO pin, and if the temperature of one of the PTC thermistors increases then its resistance also increases, and if  $V_{PTCO}$  becomes greater than or equal to  $V_{DET}$  the over temperature detection IC Thermoflagger™ detects an over temperature abnormality. If more than one PTC thermistor is used, the combined resistance of all thermistors at normal temperature (i.e., below alert temperature) must be such that  $V_{PTCO} < V_{DET}$  at normal temperature.

## 5. PCB Designs

### 5.1. Component Layout Example

Fig. 5.1 shows an example of component layout.

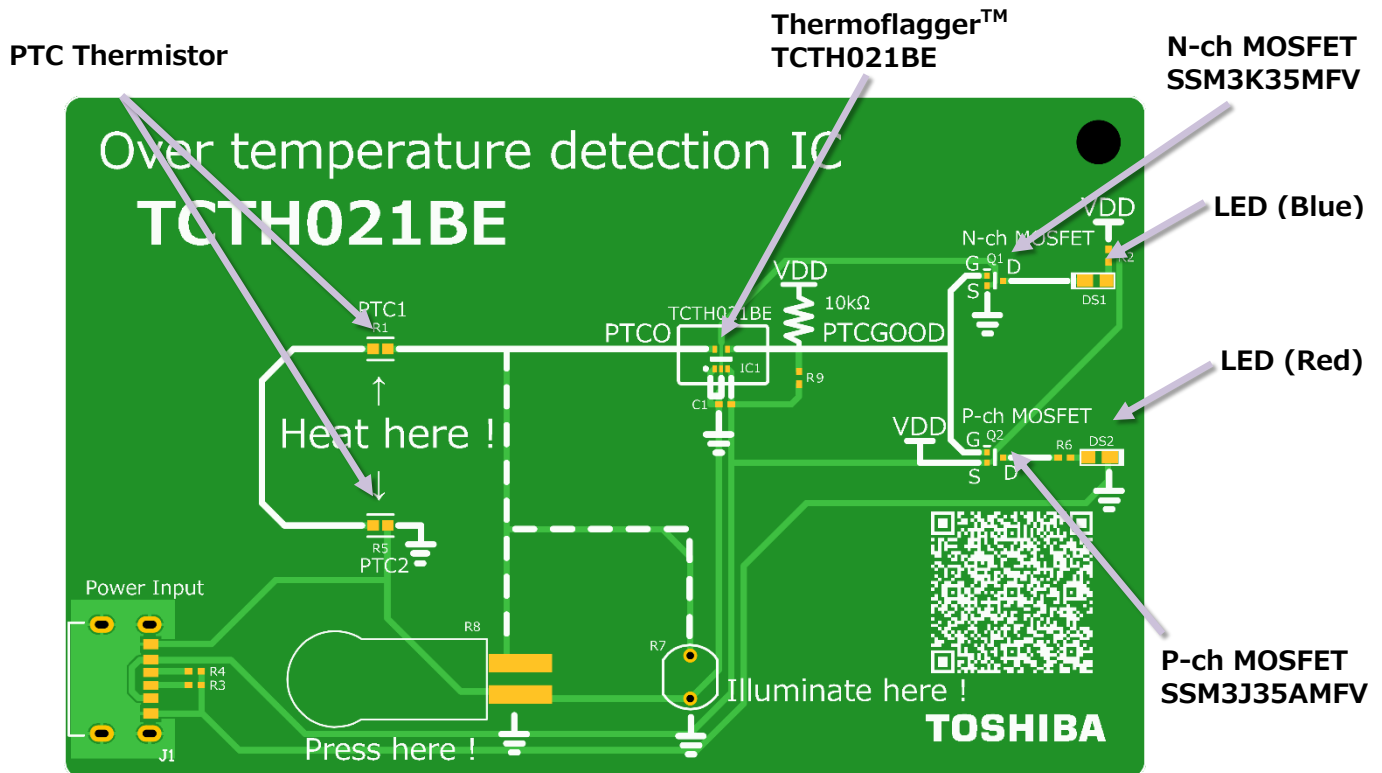

Fig. 5.1 Layout of PCB Components

- ※ Thermoflagger™ is a trademark of Toshiba Electronic Devices & Storage Corporation.
- ※ USB Type-C®, USB-C® is a registered trademark of USB Implementers Forum.
- ※ Company names, product names, and service names may be trademarks of their respective companies.

## Terms of Use

This terms of use is made between Toshiba Electronic Devices and Storage Corporation ("We") and customers who use documents and data that are consulted to design electronics applications on which our semiconductor devices are mounted ("this Reference Design"). Customers shall comply with this terms of use. Please note that it is assumed that customers agree to any and all this terms of use if customers download this Reference Design. We may, at its sole and exclusive discretion, change, alter, modify, add, and/or remove any part of this terms of use at any time without any prior notice. We may terminate this terms of use at any time and for any reason. Upon termination of this terms of use, customers shall destroy this Reference Design. In the event of any breach thereof by customers, customers shall destroy this Reference Design, and furnish us a written confirmation to prove such destruction.

### 1. Restrictions on usage

1. This Reference Design is provided solely as reference data for designing electronics applications. Customers shall not use this Reference Design for any other purpose, including without limitation, verification of reliability.
2. This Reference Design is for customer's own use and not for sale, lease or other transfer.
3. Customers shall not use this Reference Design for evaluation in high or low temperature, high humidity, or high electromagnetic environments.
4. This Reference Design shall not be used for or incorporated into any products or systems whose manufacture, use, or sale is prohibited under any applicable laws or regulations.

### 2. Limitations

1. We reserve the right to make changes to this Reference Design without notice.
2. This Reference Design should be treated as a reference only. We are not responsible for any incorrect or incomplete data and information.
3. Semiconductor devices can malfunction or fail. When designing electronics applications by referring to this Reference Design, customers are responsible for complying with safety standards and for providing adequate designs and safeguards for their hardware, software and systems which minimize risk and avoid situations in which a malfunction or failure of semiconductor devices could cause loss of human life, bodily injury or damage to property, including data loss or corruption. Customers must also refer to and comply with the latest versions of all relevant our information, including without limitation, specifications, data sheets and application notes for semiconductor devices, as well as the precautions and conditions set forth in the "Semiconductor Reliability Handbook".
4. When designing electronics applications by referring to this Reference Design, customers must evaluate the whole system adequately. Customers are solely responsible for all aspects of their own product design or applications. WE ASSUME NO LIABILITY FOR CUSTOMERS' PRODUCT DESIGN OR APPLICATIONS.
5. No responsibility is assumed by us for any infringement of patents or any other intellectual property rights of third parties that may result from the use of this Reference Design. No license to any intellectual property right is granted by this terms of use, whether express or implied, by estoppel or otherwise.
6. THIS REFERENCE DESIGN IS PROVIDED "AS IS". WE (a) ASSUME NO LIABILITY WHATSOEVER, INCLUDING WITHOUT LIMITATION, INDIRECT, CONSEQUENTIAL, SPECIAL, OR INCIDENTAL DAMAGES OR LOSS, INCLUDING WITHOUT LIMITATION, LOSS OF PROFITS, LOSS OF OPPORTUNITIES, BUSINESS INTERRUPTION AND LOSS OF DATA, AND (b) DISCLAIM ANY AND ALL EXPRESS OR IMPLIED WARRANTIES AND CONDITIONS RELATED TO THIS REFERENCE DESIGN, INCLUDING WARRANTIES OR CONDITIONS OF MERCHANTABILITY, FITNESS FOR A PARTICULAR PURPOSE, ACCURACY OF INFORMATION, OR NONINFRINGEMENT.

### 3. Export Control

Customers shall not use or otherwise make available this Reference Design for any military purposes, including without limitation, for the design, development, use, stockpiling or manufacturing of nuclear, chemical, or biological weapons or missile technology products (mass destruction weapons). This Reference Design may be controlled under the applicable export laws and regulations including, without limitation, the Japanese Foreign Exchange and Foreign Trade Law and the U.S. Export Administration Regulations. Export and re-export of this Reference Design are strictly prohibited except in compliance with all applicable export laws and regulations.

### 4. Governing Laws

This terms of use shall be governed and construed by laws of Japan.