

Inverter Circuit for IH Cooker

Design Guide

RD206-DGUIDE-01

TOSHIBA ELECTRONIC DEVICES & STORAGE CORPORATION

Contents

1. Introduction	3
1.1. IGBT Used	3
2. Circuit Design	4
2.1. Main Board Circuit Diagram.....	4
2.2. IGBT Circuit	5
2.2.1. Voltage-Resonant Soft Switching of the IGBT	6
2.2.2. IGBT Gate Drive.....	7
2.3. Power Supply for IGBT	8
2.3.1. Current Detection using Active Low-Pass Filter	9
2.3.2. Voltage and Overvoltage Detection	10
2.4. Temperature Detection.....	11
2.4.1. IGBT Temperature Detection.....	11
2.4.2. Cooking Pot Bottom Temperature Detection	11
2.5. MCU (HT45F0058)	12
2.5.1. MCU Pin Assignment.....	12
2.5.2. MCU Clock System Diagram.....	13
2.6. I2C Communication	13
2.6.1. I2C Communication Protocol.....	13

1. Introduction

This Design Guide describes how to design the various circuitry and layout of IH Cooker (hereafter referred to as this reference design) using GT20N135SRA IGBT designed for Home Appliances.

If a component is indicated as “Not Mount” in the bill of materials, then it is not mounted on the PCB, even if the part number is written in the circuit diagram.

Mounting locations are provided on the PCB for adjusting the value of various circuit components at the time of circuit design.

1.1. IGBT Used

GT20N135SRA

Toshiba’s IGBT (GT20N135SRA) used in this application are designed specifically to be used with home appliance applications to provide most operational and economical efficiency. High-speed switching, High maximum junction temperature and Low saturation voltage are some key features of GT20N135SRA IGBT.

Main features of GT20N135SRA IGBT are:

- High-speed switching: IGBT $t_f = 0.25 \mu s$ (typ.) ($I_C = 40 A$)
- Low saturation voltage: $V_{CE(sat)} = 1.60 V$ (typ.) ($I_C = 20 A, T_a = 25 \text{ }^\circ C$)
- High junction temperature: $T_j = 175 \text{ }^\circ C$ (max)
- Monolithically integrated freewheeling diode (FWD)

Main Applications of GT20N135SRA IGBT are:

- Voltage-Resonant Inverter Switching Applications
- Soft Switching Applications
- Induction Cooktops and Home Appliance Applications

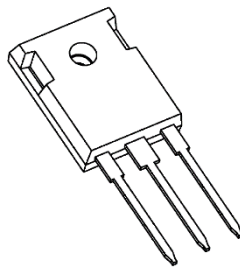

TO-247 Package

2. Circuit Design

This section describes the main points of circuit design of this power supply. Refer to RD206-SCHEMATIC-01 for the actual schematic and to RD206-BOM-01 for the bill of materials.

2.1. Main Board Circuit Diagram

Fig. 2.1 shows the circuit diagram of main board.

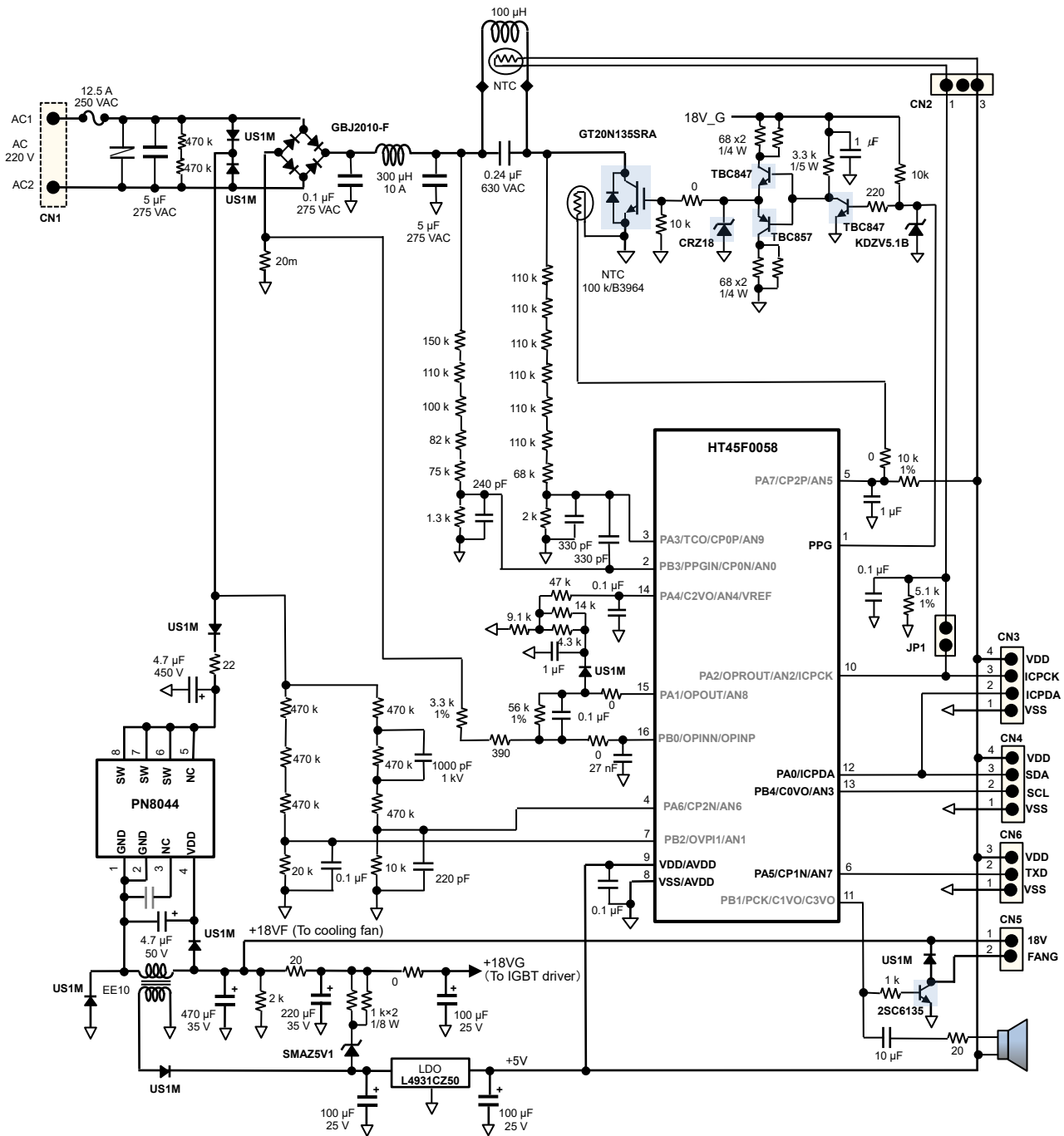

Fig. 2.1 Main Board Circuit Diagram

2.2. IGBT Circuit

Fig. 2.2 shows the circuit and components around GT20N135SRA IGBT.

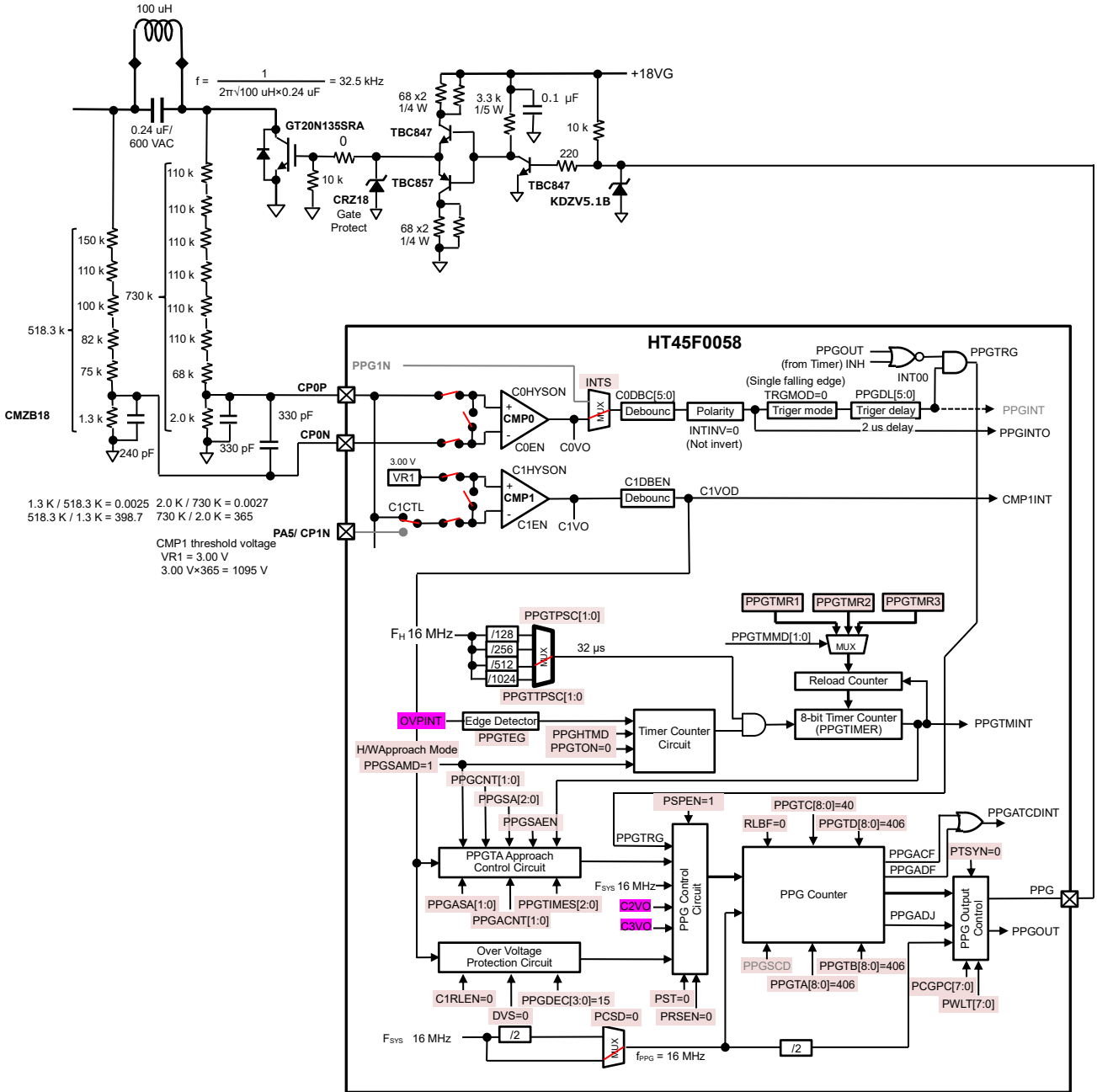

Fig. 2.2 Inverter Related Circuit

2.2.1. Voltage-Resonant Soft Switching of the IGBT

Fig. 2.3 describes the Voltage-Resonant Soft Switching operation. When the IGBT turns on, current flows through the heating coil. When the IGBT turns off, the heating coil and the resonance capacitor goes into resonance, causing sinusoidal voltage to be applied on the IGBT. The direction of resonance between heating coil and resonance capacitor reverses, causing the resonance capacitor voltage to offset the smoothing capacitor voltage. When this happens, current begins to flow through the Resonance Capacitor–Smoothing Capacitor–FWD–Resonance Capacitor loop. During this period, the collector-emitter voltage (V_{CE}) of the IGBT is equal to the forward voltage (V_F) of the freewheeling diode (FWD), which is almost zero. At this time, the IGBT turns back on. As a result, current flows through the heating coil from the input side again. This sequence keeps repeating.

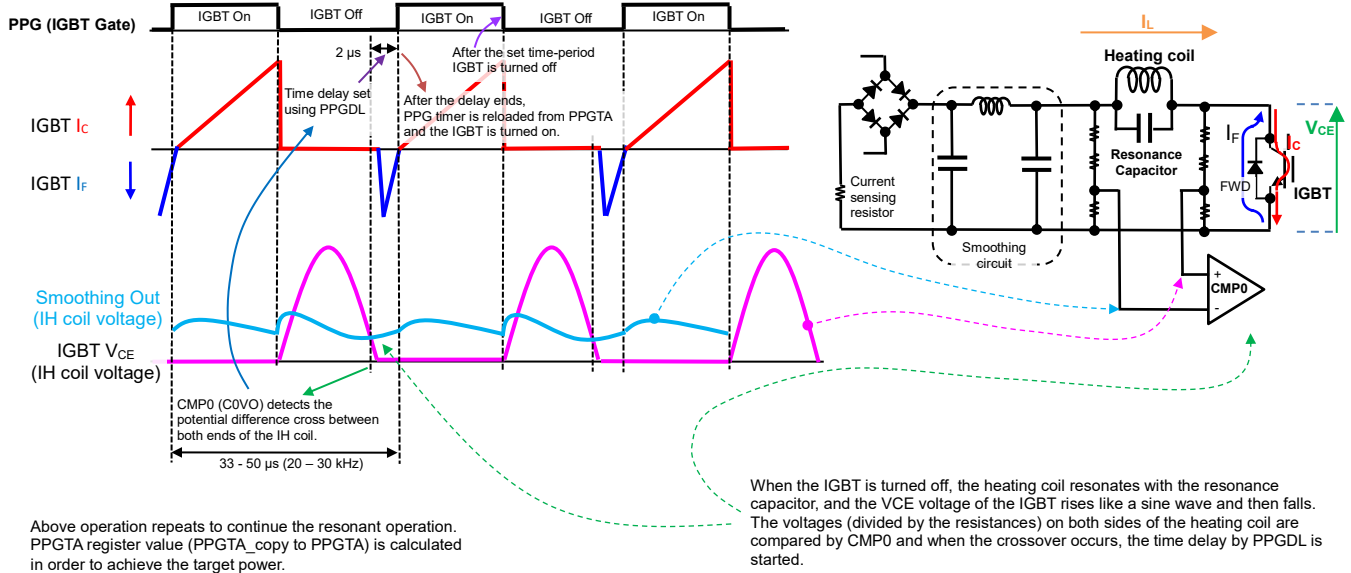

Fig. 2.3 Voltage-Resonant Soft Switching of the IGBT

2.2.2. IGBT Gate Drive

Fig. 2.4 shows IGBT gate-drive circuitry.

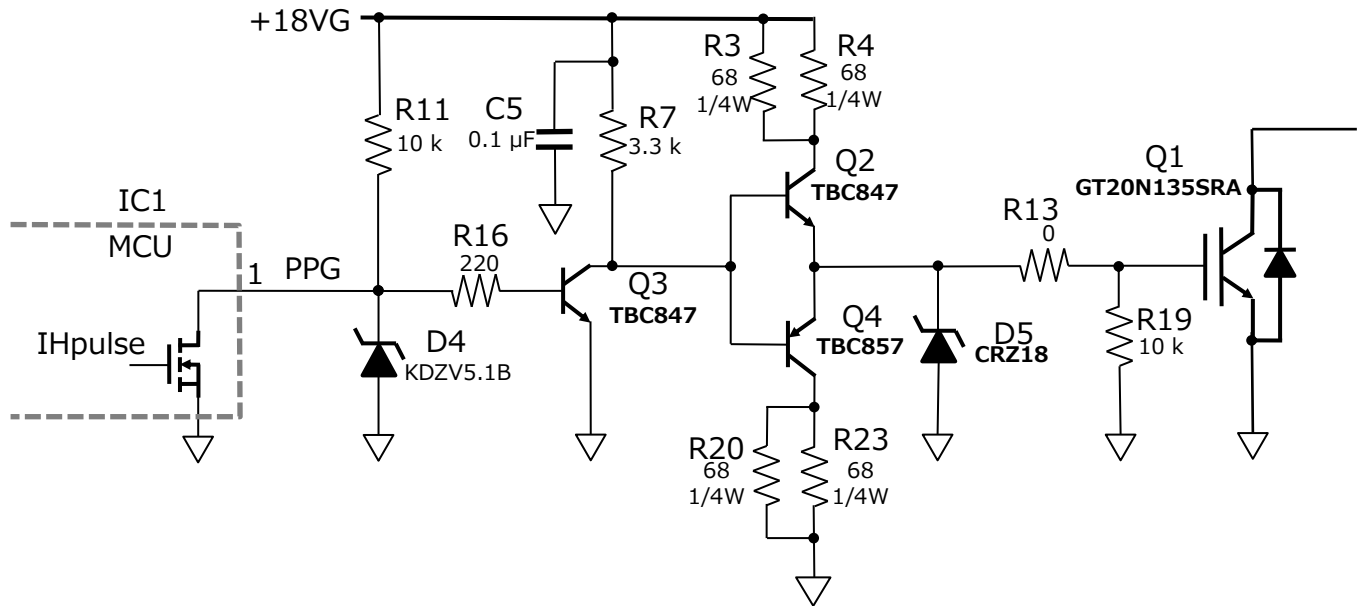

Fig. 2.4 IGBT Gating Drive Circuit

Since the IGBT gate drive pulse signal (PPG) output from the MCU is an open-drain output, it is externally pulled up by R11 and the voltage limiting zener diode D4, so that it becomes a L level output (approx. 0 V) when IHpulse signal is on and a H level output (approx. 5.1 V) when IHPulse is off.

The gate drive circuit has a push-pull (totem pole) circuit configuration. When PPG is at the L level, the bipolar transistor Q3 is turned off, and the base potentials of Q2 and Q4 are about 18 V. Therefore, the Q2 side is turned on, the base voltage to IGBT (Q1) is applied via R3 and R4, the gate charge is injected, and Q1 is turned on. When PPG is at the high level, Q3 is turned on, and the base potentials of Q2 and Q4 are about 0 V, so Q4 is turned on. The gate charges of IGBT (Q1) are emitted through R20 and R23, and Q1 is turned off.

The zener diode of D5 is used to protect the gate potential of Q1 up to 18 V.

Although the gate resistor R13 is 0 Ω in this design, check the actual switching waveform, etc., and adjust the resistance value if necessary.

2.3. Power Supply for IGBT

The IH Cooker is powered by AC 220 V (AC 180 V~AC 264 V) which is rectified by a bridge-diode to make DC as shown in the figure below.

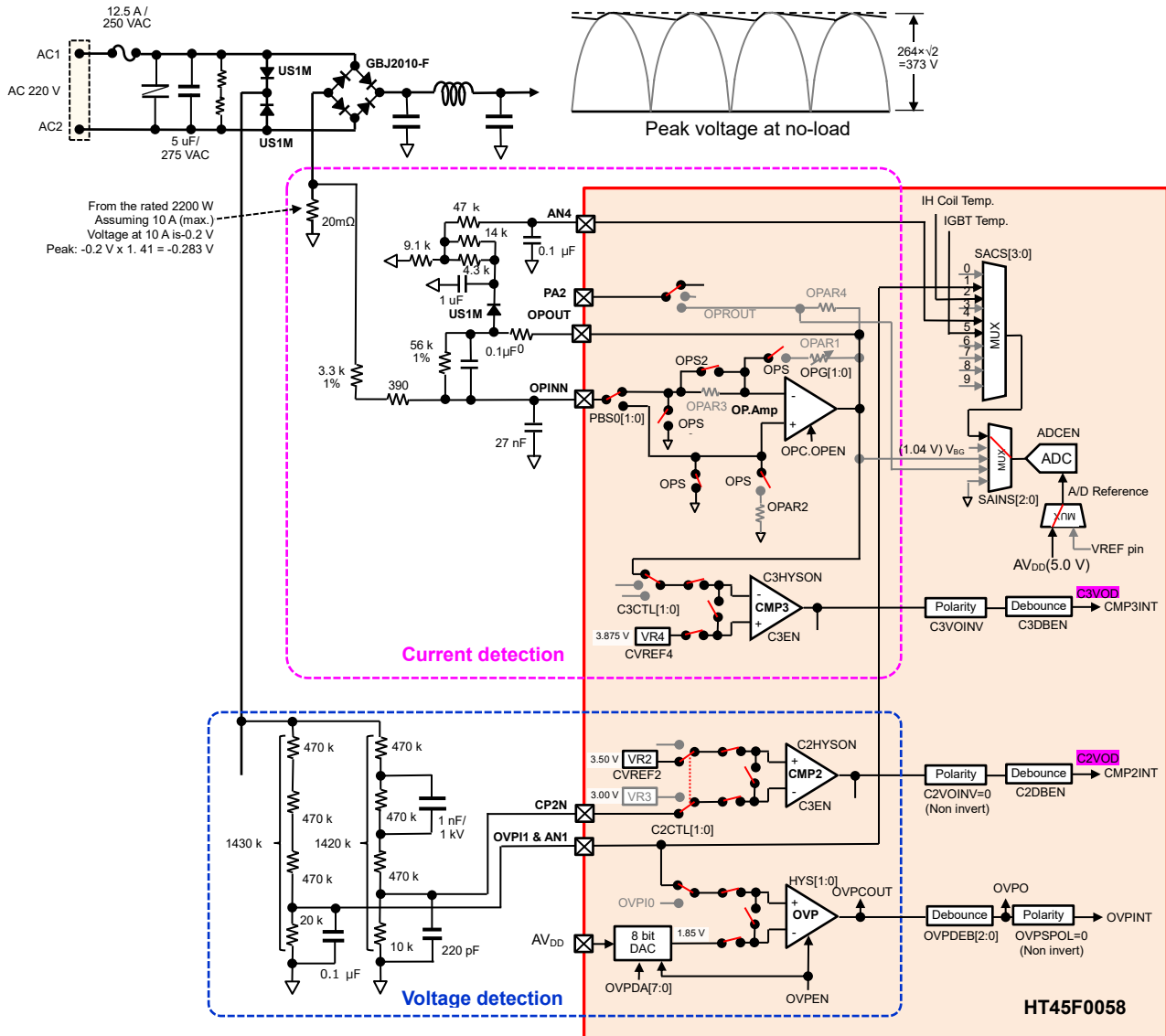

Fig. 2.5 Power Supply for IGBT

2.3.1. Current Detection using Active Low-Pass Filter

Current is detected by using a 20 mΩ resistor, which is connected to the diode bridge. Since the voltage generated by 20 mΩ resistor is low, amplification is performed using Op.Amp inside the HT45F0058 MCU. However, since the switching frequency of the IGBT is between 20 kHz and 30 kHz, the current cannot be measured directly. Since bridge rectification is performed, the waveform has a frequency of 100 Hz (10 ms cycle), which is twice the AC power frequency of 50 Hz. Therefore, a filter is used to measure the current value using only the DC component.

The steps for current detection using active low-pass filter are described in the following Fig. 2.5.

1. Figure shows a waveform of 20 kHz to 30 kHz because of IGBT switching.
2. Filtering is performed using an inverting amplifier with first order Low Pass Filter.

The gain is considered so that the output voltage when the current consumption is 10 A falls within the setting range (CVREF4) of the comparison voltage VR4 of CMP3. Refer to Fig. 2.4.
3. Diode and Capacitor are used to make the signal more stable.
4. Voltage divider circuit is used to adjust the signal voltage level.
5. RC filter is used to filter the signal again. Output is sent to ADC.
6. Firmware is used to filter the ADC output signal.

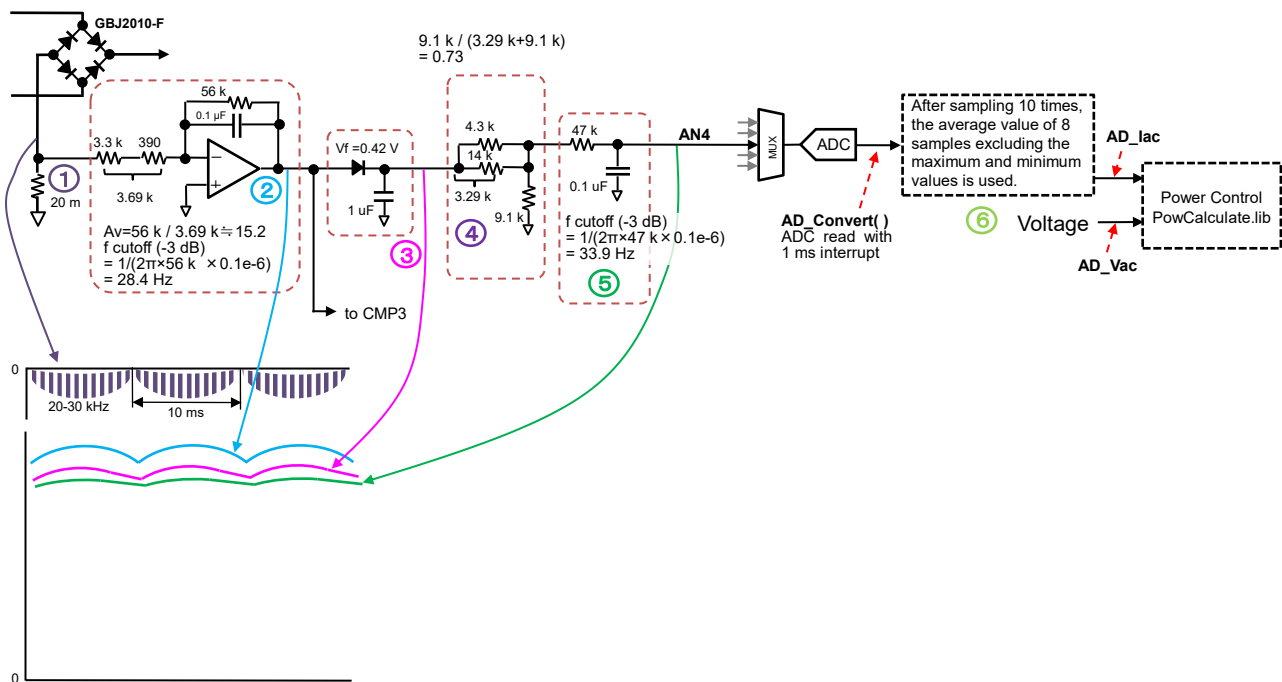

Fig. 2.6 Current Detection using Active Low-Pass Filter

Since the rating of fuse on board is 10 A, the overcurrent detection (E7 error) value needs to be 10 A or less; therefore, 9.8 A is set as the threshold value.

2.3.2. Voltage and Overvoltage Detection

Fig. 2.6 shows the circuit used for detection of Voltage and Overvoltage.

The output voltage of diode-bridge is lowered using the voltage divider resistor circuit. The signal from left voltage divider circuit shown below is filtered using a LPF and then sent to the ANI1 pin for reading voltage value. (This signal is shown by green color in the figure below.)

This device reads the following at every 20 ms interval:

AC power supply voltage → pot bottom temperature → current → IGBT temperature

The ADC takes 10 samples with 1 ms interval between samples. Then the average of 8 samples is taken after excluding the maximum / minimum values. It takes 10 ms for taking 10 samples, which is same as one cycle of the full-wave rectifier output.

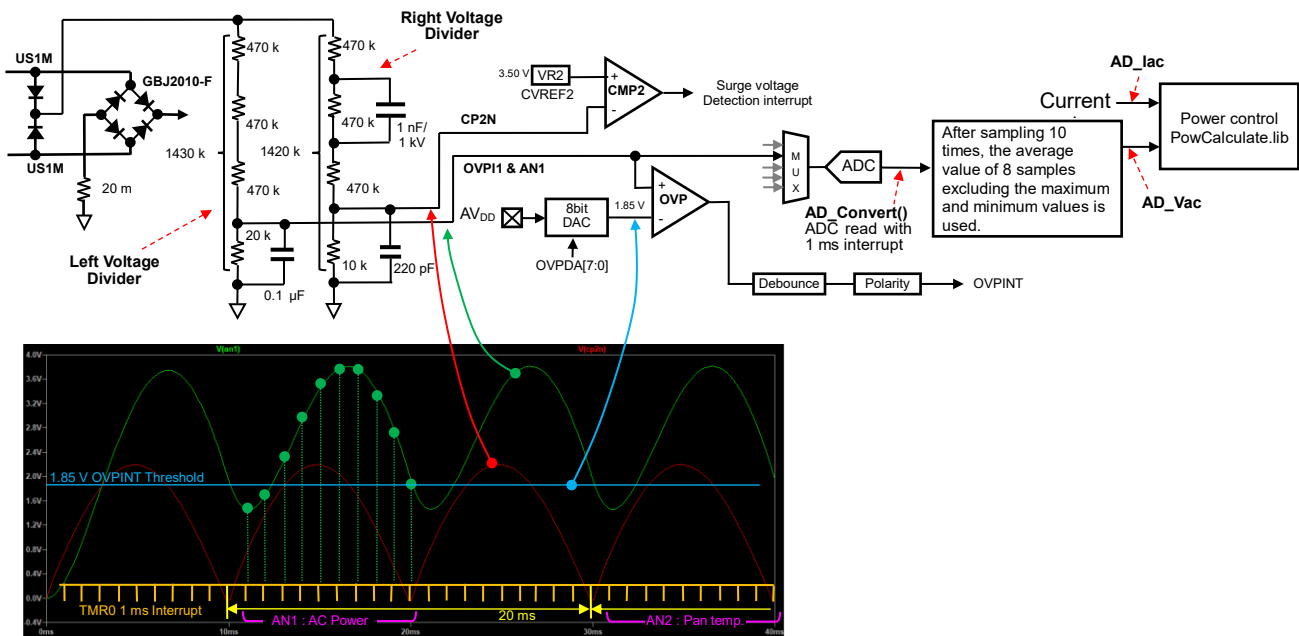

Fig. 2.7 Voltage and Overvoltage Detection

The right voltage divider and LPF is used for detecting the Overvoltage. Output voltage (shown by red in above image) of this circuit is sent to comparator CMP2 for Overvoltage detection. If CMP2 interrupt is detected, the IGBT is turned off. In addition, if this interrupt does not recur for 3 seconds, normal operation is restored.

2.4. Temperature Detection

In this IH Cooker, Thermistors are used to detect temperature of IGBT and cooking pot bottom.

2.4.1. IGBT Temperature Detection

Thermistor for measuring the temperature of IGBT is mounted on the PCB near IGBT. Thermistor is connected in a voltage divider configuration and ADC is used to read its output voltage. Fig. 2.7 shows the circuit diagram and thermistor position.

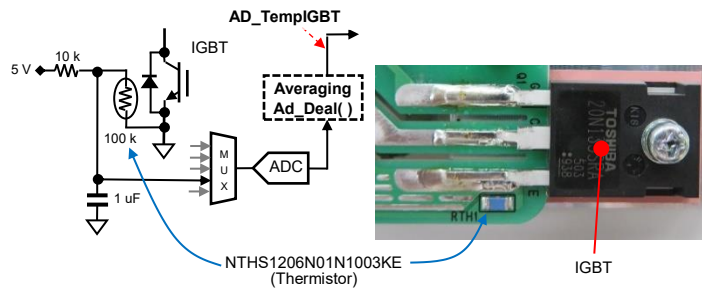

Fig. 2.8 IGBT Temperature Detection

2.4.2. Cooking Pot Bottom Temperature Detection

The thermistor for measuring the temperature of the bottom of the cooking pot is mounted in the center of the IH coil. Thermistor is connected in a voltage divider configuration and ADC is used to read its output voltage. Fig. 2.8 shows the circuit diagram and thermistor position.

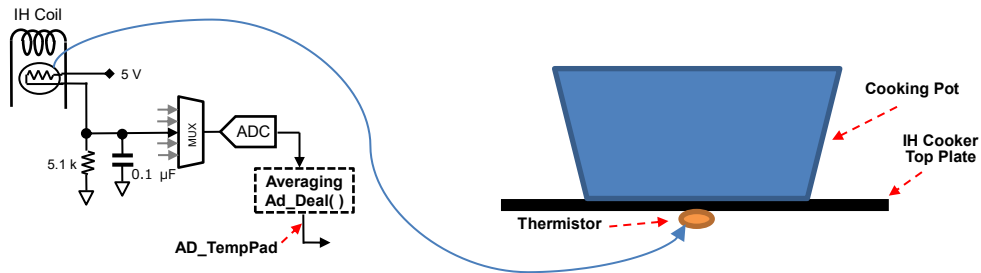

Fig. 2.9 Cooking Pot Bottom Temperature Detection

2.5. MCU (HT45F0058)

HT45F0058 MCU is used for controlling the operation of this IH Cooker.

2.5.1. MCU Pin Assignment

The selected function of each pin is shown in the Fig. 2.9 and the description of each Pin assignment given in the Table 2.1.

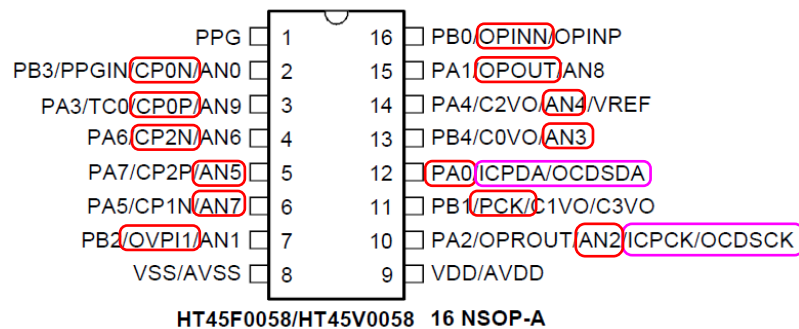

Fig. 2.10 MCU Pin Function

Table. 2.1 MCU Pin Assignment

Pin	Pin Name	I/O	Selected Function	Description
1	PPG	OD		For IGBT drive circuit
2	PB3/PPGIN/CP0N/AN0	I	CP0N	IH coil voltage detection comparator 0 (-) input
3	PA3/TC0/CP0P/AN9	I	CP0P	IH coil voltage detection comparator 0 (+) input
4	PA6/CP2N/AN6	I	CP2N	Comparator 2 (-) input
5	PA7/CP2P/AN5	I	AN5	For IGBT temperature-sensing thermistor
6	PA5/CP1N/AN7	O	PA5	Serial Out for Debug (TXD)
7	PB2/OVPI1/AN1	I	OVPI1/AN1	For comparator and ADC used for overvoltage detection
8	VSS/AVSS			
9	VDD/AVDD			+5 V
10	PA2/OPROUT/AN2/ICPCK/OCDSCK	I	AN2/ICPCK	Bottom temperature detection thermistor/for writing MCU
11	PB1/PCK/C1VO/C3VO	O	PCK	For FAN control
12	PA0/ICPDA/OCSDA	I/O	PA0/ICPDA	For I2C-bus SDA / For writing to MCU
13	PB4/C0VO/AN3	I/O	PB4	For I2C-bus SCL
14	PA4/AN4/VREF	I	AN4	Input for current detection (from op amp output)
15	PA1/OPOUT/AN8	O	OPOUT	Operational amplifier output for current detection
16	PB0/OPINN/OPINP	I	OPPIN	Operational amplifier (-) input for current detection

2.5.2. MCU Clock System Diagram

Fig. 2.10 shows the clock system diagram of HT45F0058 MCU.

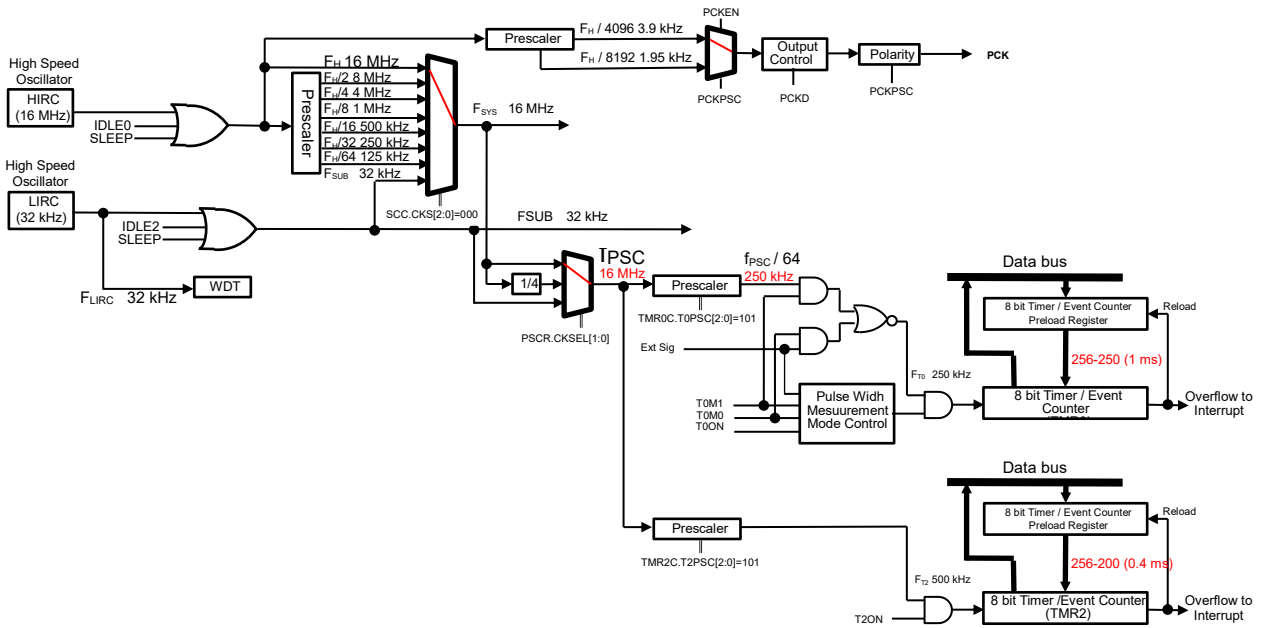

Fig. 2.11 MCU Clock System Diagram

2.6. I2C Communication

The MCU of main board communicates with the control board using I2C-bus, and this I2C-bus function is implemented using software control of GPIO.

2.6.1. I2C Communication Protocol

Fig. 2.11 show the I2C communication protocol used in this system.

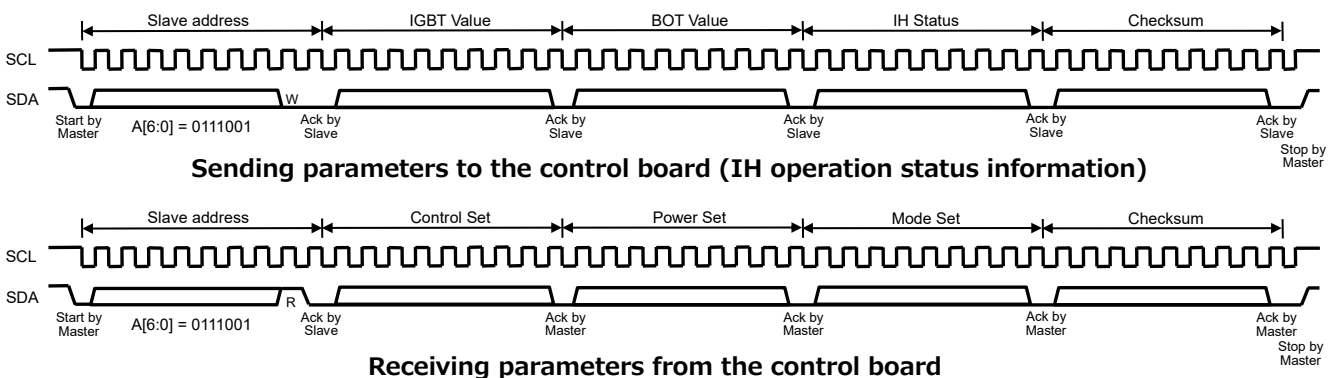

Fig. 2.12 I2C Communication Protocol

Details of various I2C protocol parameters used while sending data to the control board (sending IH operation status information) are as follows:

IGBT_Value

Bit 7	Bit 6	Bit 5	Bit 4	Bit 3	Bit 2	Bit 1	Bit 0
IGBT_D7	IGBT_D6	IGBT_D5	IGBT_D4	IGBT_D3	IGBT_D2	IGBT_D1	IGBT_D0

Upper 8-bit read value of A/D converter AN5 (IGBT temperature sensing thermistor).

BOT_Value

Bit 7	Bit 6	Bit 5	Bit 4	Bit 3	Bit 2	Bit 1	Bit 0
BOT_D7	BOT_D6	BOT_D5	BOT_D4	BOT_D3	BOT_D2	BOT_D1	BOT_D0

Upper 8-bit read value of A/D converter AN2 (pot bottom temperature-sensing thermistor).

IH_Status

Bit 7	Bit 6	Bit 5	Bit 4	Bit 3	Bit 2	Bit 1	Bit 0
B_ChkSum[2:0]			POT_Chk	STATUS[3]	STATUS[2]	STATUS[1]	STATUS[0]

Status of this equipment, etc.

B_ChkSum[2:0] (Byte checksum)

B_ChkSum[2] = bit2(STATUS[2]) inverted

B_ChkSum[1] = bit1(STATUS[1]) inverted

B_ChkSum[0] = bit0(STATUS[0]) inverted

POT_Chk (Pot check)

0 With pot

1 Without ladle

STATUS[3:0] (IH Error status)

0000(0h) Normal operation

0001(1h) Reserved

0010(2h) Circuit failure (overcurrent, no synchronization)

0011(3h) IGBT overheat (110 °C or higher)

0100(4h) IGBT temperature sensor (thermistor) failure

0101(5h) Heating surface (IH coil) overheat (188 °C or higher)

0110(6h) Heating surface (IH coil) temperature sensor (thermistor) failure

0111(7h) AC-input overcurrent (above 9.8 A)

1000(8h) AC-input overvoltage (270 V or more)

1001(9h) AC-input low voltage (less than 150 V)

1010(Ah) I2C-bus communication failure (this error is not implemented)

1011(Bh) Reserved

:

1111(Fh) Reserved

Details of various I2C protocol parameters used while receiving data from the control board (receiving IH operation control information) are as follows:

Control_Set

Bit 7	Bit 6	Bit 5	Bit 4	Bit 3	Bit 2	Bit 1	Bit 0
B_ChkSum[3:0]				OnOffCnt	Buz[1]	Buz[0]	FanCnt

Status of the equipment, etc.

B_ChkSum[3:0] (Byte checksum)

B_ChkSum[2] = bit3(OnOffCnt) inverted

B_ChkSum[2] = bit2(Buz[1]) inverted

B_ChkSum[1] = bit1(Buz[10]) inverted

B_ChkSum[0] = bit0(FanCnt) inverted

OnOffCnt (ON / OFF Control)

Power ON/OFF control.

0 OFF

1 ON

Bzz[1:0] (Buzzer Control)

Buzzer control.

00 Silence

01 200 ms sound

10 sound 2 times

11 1 second sound

FanCnt (FAN Control)

Air cooling fan control.

0 Air cooling fan stop

1 Air cooling fan ON

Power_Set

Bit 7	Bit 6	Bit 5	Bit 4	Bit 3	Bit 2	Bit 1	Bit 0
PwrStep[7]	PwrStep[6]	PwrStep[5]	PwrStep[4]	PwrStep[3]	PwrStep[2]	PwrStep[1]	PwrStep[0]

Power Set is used for heating power control.

0d clear power

5d 100 W

15d 300 W

30d 600 W

50d 1000 W

60d 1200 W

70d 1400 W

80d 1600 W

90d 1800 W

100d 2000 W

Mode_Set

Bit 7	Bit 6	Bit 5	Bit 4	Bit 3	Bit 2	Bit 1	Bit 0
MSet[7]	MSet[6]	MSet[5]	MSet[4]	MSet[3]	MSet[2]	MSet[1]	MSet[0]

Used to describe Continuous power or intermittent power.

MSet[7:0] (Mode set)

01h Continuous operation

02h Intermittent operation

Terms of Use

This terms of use is made between Toshiba Electronic Devices and Storage Corporation (“We”) and customers who use documents and data that are consulted to design electronics applications on which our semiconductor devices are mounted (“this Reference Design”). Customers shall comply with this terms of use. Please note that it is assumed that customers agree to any and all this terms of use if customers download this Reference Design. We may, at its sole and exclusive discretion, change, alter, modify, add, and/or remove any part of this terms of use at any time without any prior notice. We may terminate this terms of use at any time and for any reason. Upon termination of this terms of use, customers shall destroy this Reference Design. In the event of any breach thereof by customers, customers shall destroy this Reference Design, and furnish us a written confirmation to prove such destruction.

1. Restrictions on usage

1. This Reference Design is provided solely as reference data for designing electronics applications. Customers shall not use this Reference Design for any other purpose, including without limitation, verification of reliability.
2. This Reference Design is for customer's own use and not for sale, lease or other transfer.
3. Customers shall not use this Reference Design for evaluation in high or low temperature, high humidity, or high electromagnetic environments.
4. This Reference Design shall not be used for or incorporated into any products or systems whose manufacture, use, or sale is prohibited under any applicable laws or regulations.

2. Limitations

1. We reserve the right to make changes to this Reference Design without notice.
2. This Reference Design should be treated as a reference only. We are not responsible for any incorrect or incomplete data and information.
3. Semiconductor devices can malfunction or fail. When designing electronics applications by referring to this Reference Design, customers are responsible for complying with safety standards and for providing adequate designs and safeguards for their hardware, software and systems which minimize risk and avoid situations in which a malfunction or failure of semiconductor devices could cause loss of human life, bodily injury or damage to property, including data loss or corruption. Customers must also refer to and comply with the latest versions of all relevant our information, including without limitation, specifications, data sheets and application notes for semiconductor devices, as well as the precautions and conditions set forth in the "Semiconductor Reliability Handbook".
4. When designing electronics applications by referring to this Reference Design, customers must evaluate the whole system adequately. Customers are solely responsible for all aspects of their own product design or applications. WE ASSUME NO LIABILITY FOR CUSTOMERS' PRODUCT DESIGN OR APPLICATIONS.
5. No responsibility is assumed by us for any infringement of patents or any other intellectual property rights of third parties that may result from the use of this Reference Design. No license to any intellectual property right is granted by this terms of use, whether express or implied, by estoppel or otherwise.
6. THIS REFERENCE DESIGN IS PROVIDED "AS IS". WE (a) ASSUME NO LIABILITY WHATSOEVER, INCLUDING WITHOUT LIMITATION, INDIRECT, CONSEQUENTIAL, SPECIAL, OR INCIDENTAL DAMAGES OR LOSS, INCLUDING WITHOUT LIMITATION, LOSS OF PROFITS, LOSS OF OPPORTUNITIES, BUSINESS INTERRUPTION AND LOSS OF DATA, AND (b) DISCLAIM ANY AND ALL EXPRESS OR IMPLIED WARRANTIES AND CONDITIONS RELATED TO THIS REFERENCE DESIGN, INCLUDING WARRANTIES OR CONDITIONS OF MERCHANTABILITY, FITNESS FOR A PARTICULAR PURPOSE, ACCURACY OF INFORMATION, OR NONINFRINGEMENT.

3. Export Control

Customers shall not use or otherwise make available this Reference Design for any military purposes, including without limitation, for the design, development, use, stockpiling or manufacturing of nuclear, chemical, or biological weapons or missile technology products (mass destruction weapons). This Reference Design may be controlled under the applicable export laws and regulations including, without limitation, the Japanese Foreign Exchange and Foreign Trade Law and the U.S. Export Administration Regulations. Export and re-export of this Reference Design are strictly prohibited except in compliance with all applicable export laws and regulations.

4. Governing Laws

This terms of use shall be governed and construed by laws of Japan.