

# Application Circuit of Low Noise Op-Amp TC75S67TU for Pulse Sensor

## Reference Guide

**RD159-RGUIDE-02**

---

### Overview

This reference guide describes the specifications, circuits, circuit patterns, usage, and operation of the pulse sensor using the low-noise operational amplifier TC75S67TU (hereinafter, this sensor). This sensor is used a microcontroller and configured to display the operation control and measurement status on a PC. Please refer when designing pulse sensors using TC75S67TU.

**TOSHIBA ELECTRONIC DEVICES & STORAGE CORPORATION**

## Contents

<b>1. Introduction</b>	<b>3</b>
<b>2. Specifications and appearance of the pulse sensor</b>	<b>4</b>
2.1. Pulse sensor specifications	4
2.2. Feature	4
<b>3. Circuit and board pattern of the pulse sensor</b>	<b>6</b>
3.1. Circuit diagrams	6
3.2. Bill of materials (sensor circuit)	7
3.3. Bill of materials (amplifier circuit)	8
3.4. Board pattern drawing (flexible board)	9
3.5. Board pattern drawing (rigid board)	14
<b>4. Operation procedure</b>	<b>18</b>
4.1. About Arduino and Processing	18
4.2. Connecting to the Arduino	18
4.3. Start and stop	19
4.4. Precautions for measurement	21
<b>5. Pulse measurement</b>	<b>22</b>

## 1. Introduction

The pulse sensor described in this reference guide is a reflective pulse sensor using an light sensor SFH7051 manufactured by OSRAM Corporation as a sensor device. The sensor unit, which detects the amount of light reflected in the living body, and the amplifier unit, which amplifies the output signal from the sensor unit, are separate boards. The sensor unit is made of a flexible board for consideration of wearable applications in which the sensor unit is brought into direct contact with the living body.

The sensor and amplifier are connected by a three-wire cable, and the signal from the sensor is amplified by the amplifier and output to the microcontroller. In the document, the microcontroller is the Arduino, and it controls the operation of this sensor and display the results on the PC. Since the power supply also uses a 5 V DC voltage supplied from the Arduino, it can be used as a pulse sensor if there is the Arduino and a personal computer in addition to this sensor.

Various information on this sensor reference design is provided from here → [Click Here](#)

Components other than Op-amps are also surface-mounted, and the sensor section is 30 mmφ and the amplifier section is 20 mm×20 mm, making the circuit board compact and easy to use.

Note that the circuit and board pattern prepared in the reference design of the pulse sensor described in this guide are provided with jumpers and lands for unmounted elements in consideration of scalability such as changing the bias voltage of the Op-amp. In circuit diagrams and bill of materials, jumpers are written as 0 Ω, and unmounted elements are written as "Not mounted". Also, the wiring on the circuit diagram is indicated by a dotted line.

## 2. Specifications and appearance of the pulse sensor

### 2.1. Pulse sensor specifications

**Table 2.1 Specifications of the pulse sensors**

Item	Specifications
I/F	Arduino connections
Control method	Control from Arduino and Shield connected PCs
Power supply voltage	5 V supplied from Arduino and Shield board
Onboard pulse sensor	OSRAM Co., Ltd.'s SFH7051
Emission wavelength	530nm
On-board Op-amp	TC75S67TU manufactured by Toshiba Devices & Storage Co., Ltd.

### 2.2. Feature

<Entire>

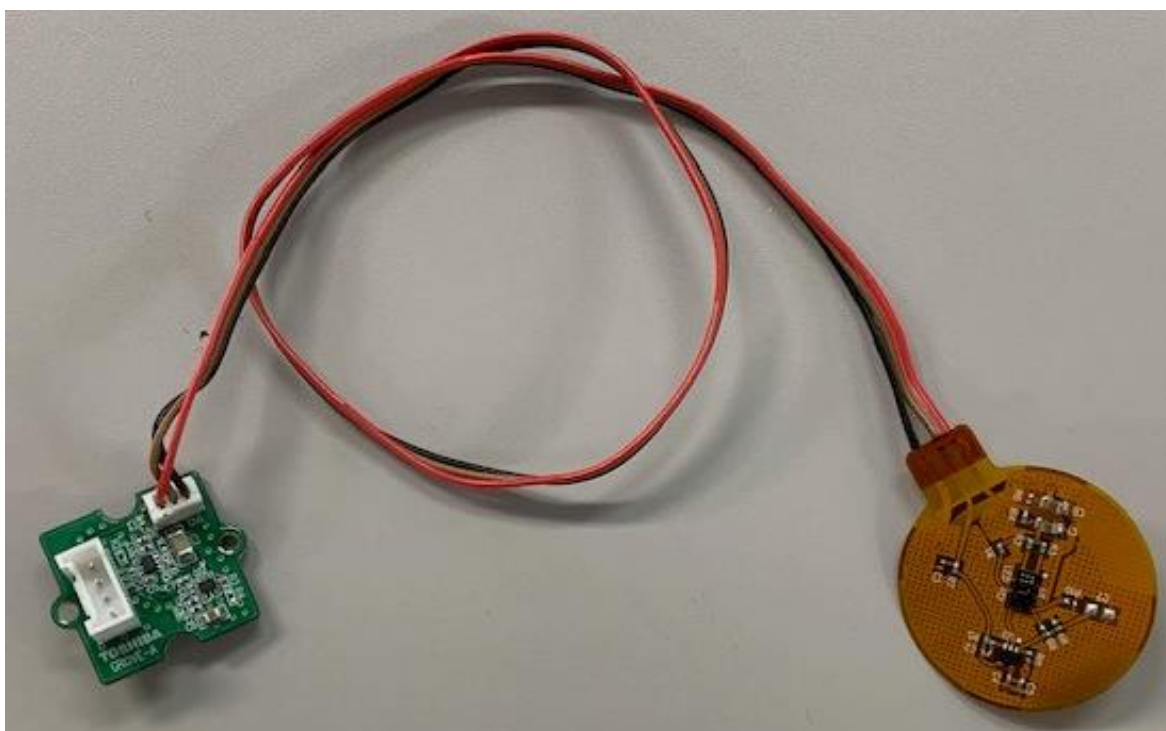

**Fig. 2.1 Pulse sensor**

<Sensor circuit>

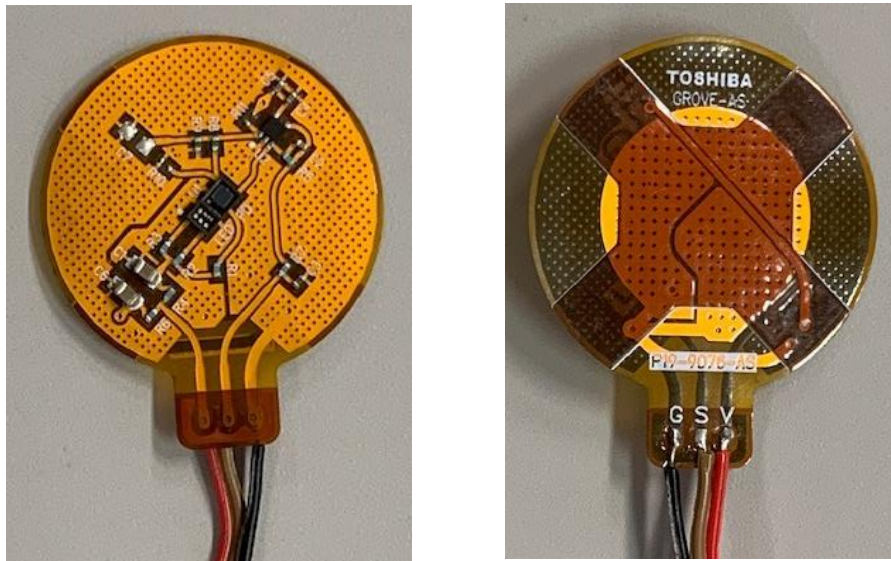

Fig. 2.2 Sensor circuit (Flexible board)

<Amplifier circuit>

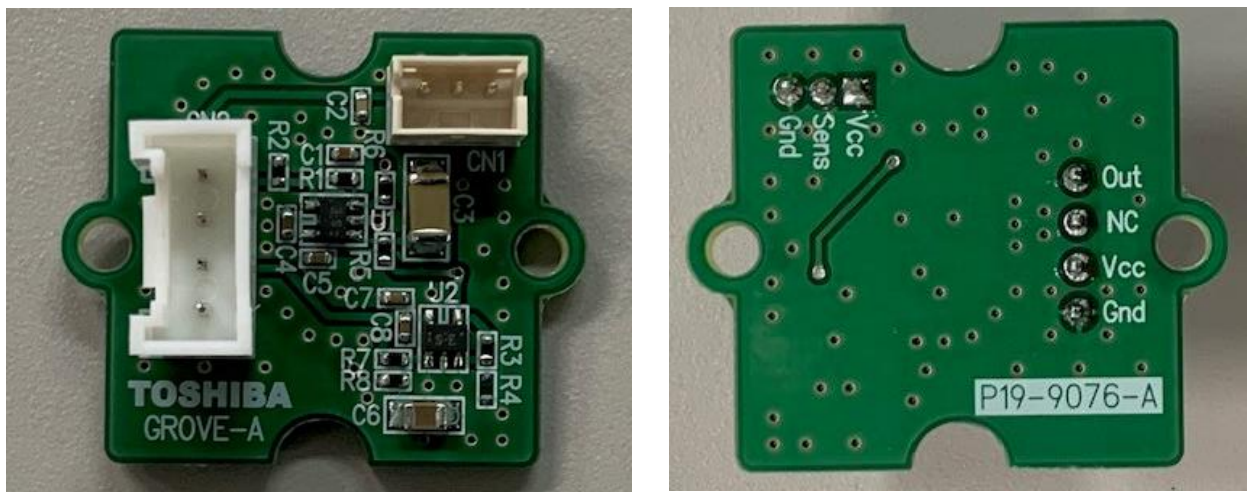

Fig. 2.3 Amplifier circuit (Rigid board)

## 3. Circuit and board pattern of the pulse sensor

### 3.1. Circuit diagrams

<Sensor circuit>

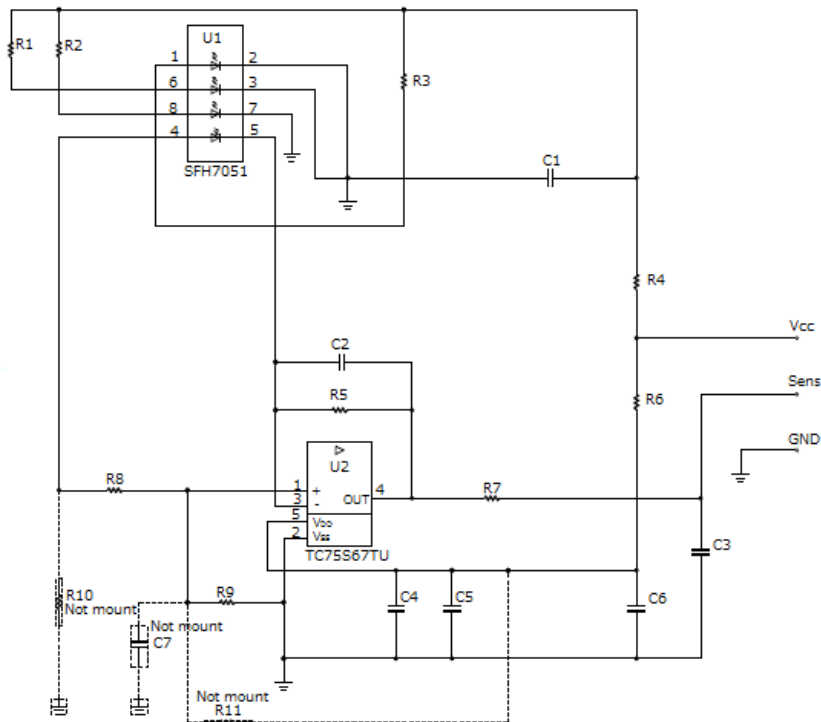

Fig. 3.1 Sensor circuit diagram

<Amplifier circuit>

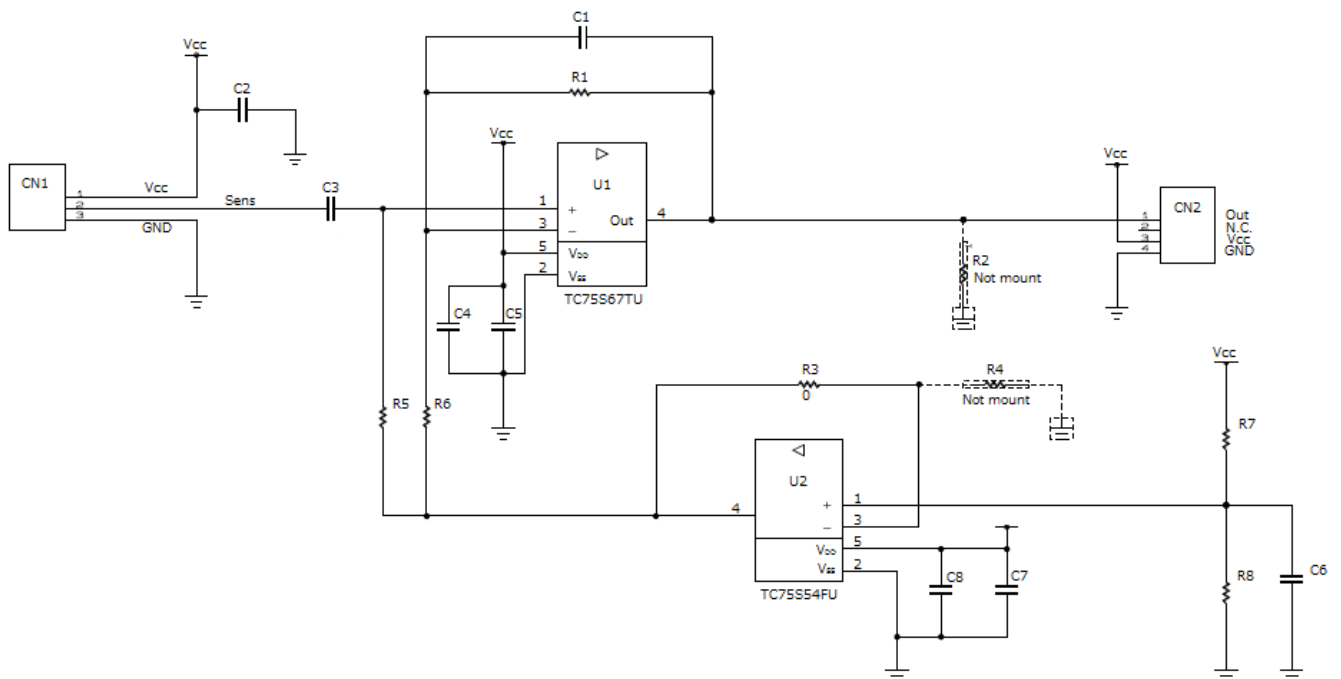

Fig. 3.2 Amplifier circuit diagram

### 3.2. Bill of materials (sensor circuit)

**Table 3.1 Bill of Materials (Sensor circuit)**

Item	Part	Quantity	Value	Part name	Manufacturer	Description	Package Name	Standard dimension Mm (inch)	Comments
1	U1	1	-	SFH7051	OSRAM	Photo sensor		4.7×2.5×0.9	
2	U2	1	-	TC75S67TU	TOSHIBA	Operational amplifier	SOT-353F	2.0×2.1×0.7	
3	C1, C6	2	10 μF			Ceramic 25 V, ±10 %		2.0×1.2 (0805)	
4	C2	1	3.3 nF			Ceramic 50 V, ±10 %		1.0×0.5 (0402)	
5	C3	1	1 μF			Ceramic 6.3 V, ±10 %		1.0×0.5 (0402)	
6	C4	1	10 nF			Ceramic 25 V, ±10 %		1.0×0.5 (0402)	
7	C5	1	100 nF			Ceramic 16 V, ±10 %		1.0×0.5 (0402)	
8	C7	1						2.0×1.2 (0805)	Not mounted Operational amplifier For changing the bias
9	R1, R2, R3, R7	4	1 kΩ			100 mW, ±1 %		1.0×0.5 (0402)	
10	R4	1	22 Ω			100 mW, ±1 %		1.0×0.5 (0402)	
11	R5	1	470 kΩ			100 mW, ±1 %		1.0×0.5 (0402)	
12	R6	1	100 Ω			100 mW, ±1 %		1.0×0.5 (0402)	
13	R8, R9	1	0 Ω			1 A		1.0×0.5 (0402)	
14	R10, R11	2						1.0×0.5 (0402)	Not mounted Operational amplifier For changing the bias

### 3.3. Bill of materials (amplifier circuit)

**Table 3.2 Bill of Materials (Amplifier circuit)**

Item	Part	Quantity	Value	Part name	Manufacturer	Description	Package Name	Standard dimension Mm (inch)	Comments
1	U1	1	-	TC75S67TU	TOSHIBA	Operational amplifier	SOT-353F	2.0×2.1×0.7	
2	U2	1	-	TC75S54FU	TOSHIBA	Operational amplifier	SOT-353	2.0×2.1×0.9	
3	C1	1	150 nF			Ceramic 6.3 V, ±10 %		1.0×0.5 (0402)	
4	C2	1	1 μF			Ceramic 6.3 V, ±10 %		1.0×0.5 (0402)	
5	C3	1	100 μF			Ceramic 6.3 V, ±10 %		3.2×1.6 (1206)	
6	C4, C8	2	10 nF			Ceramic 25 V, ±10 %		1.0×0.5 (0402)	
7	C5, C7	2	100 nF			Ceramic 16 V, ±10 %		1.0×0.5 (0402)	
8	C6	1	10 μF			Ceramic 25 V, ±10 %		2.0×1.2 (0805)	
9	R1, R5	2	10 kΩ			100 mW, ±1 %		1.0×0.5 (0402)	
10	R2, R4	2						1.0×0.5 (0402)	Not mounted Reference voltage For change
11	R3	1	0 Ω			1 A		1.0×0.5 (0402)	
12	R6	1	100 Ω			100 mW, ±1 %		1.0×0.5 (0402)	
13	R7, R8	2	1 kΩ			100 mW, ±1 %		1.0×0.5 (0402)	
14	CN1	1	-	B3B-ZR	JST	Connector 3 pin/straight		6×4.5×3.5	
15	CN2	1	-	110990030	Seeed Studio	Grove connector 4 pin/straight		10×5.1×8.1	



**3.4. Board pattern drawing (flexible board)**

A reinforcing plate is provided on the flexible board to prevent damage during mounting.  
 <Front (part mounting side)>

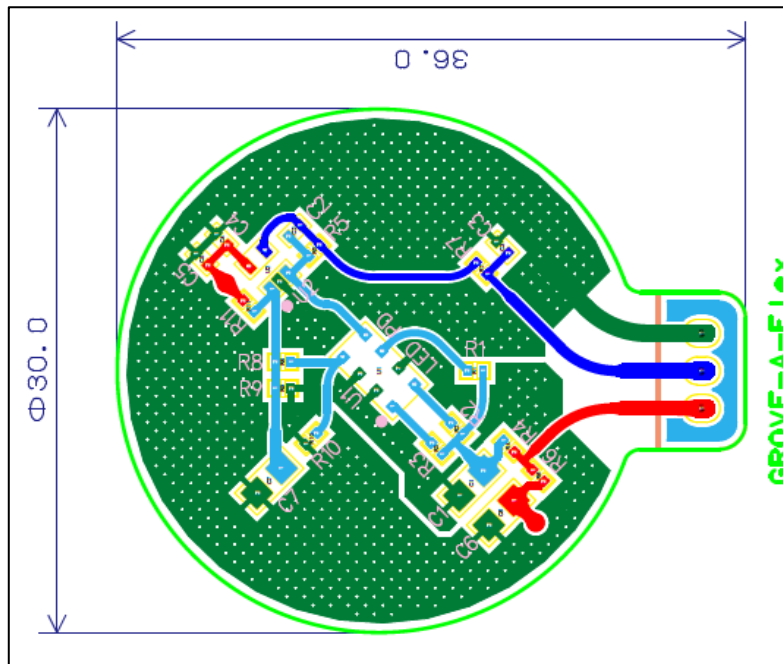

**Fig. 3.3 Front surface pattern**

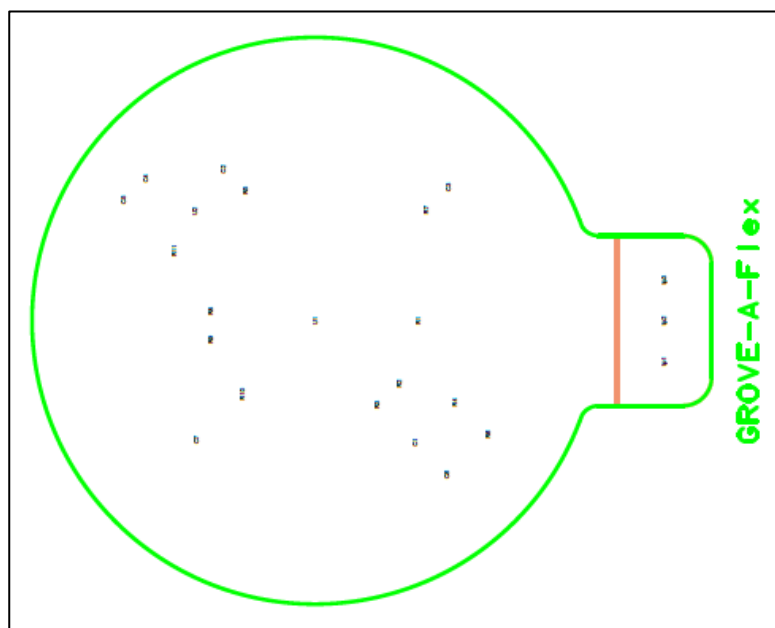

**Fig. 3.4 Front surface reinforcement plate**

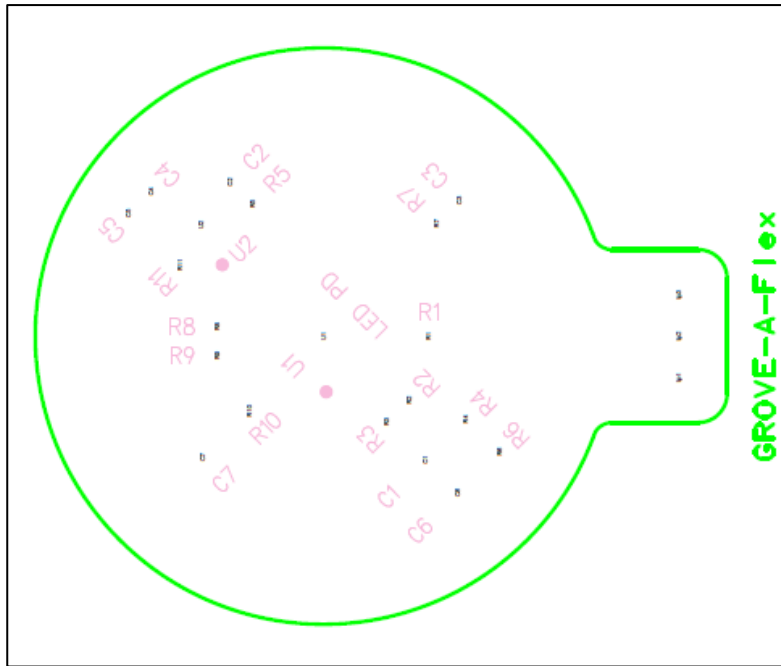

Fig. 3.5 Front surface silk

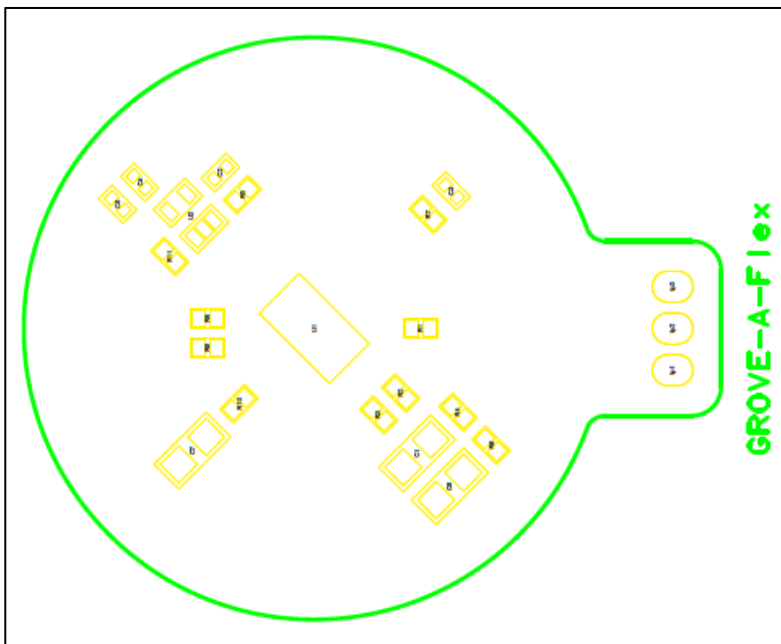
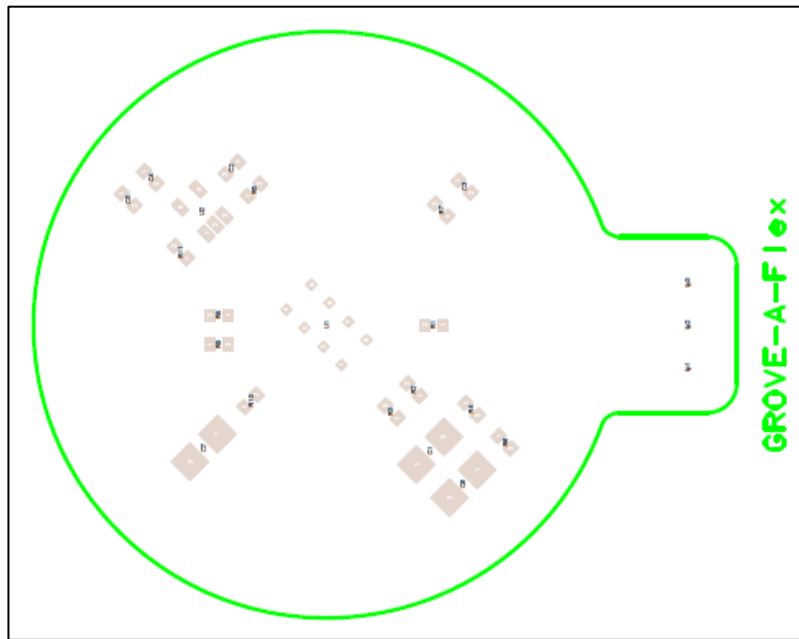

Fig. 3.6 Front surface solder



**Fig. 3.7 Front surface paste**

<Back>

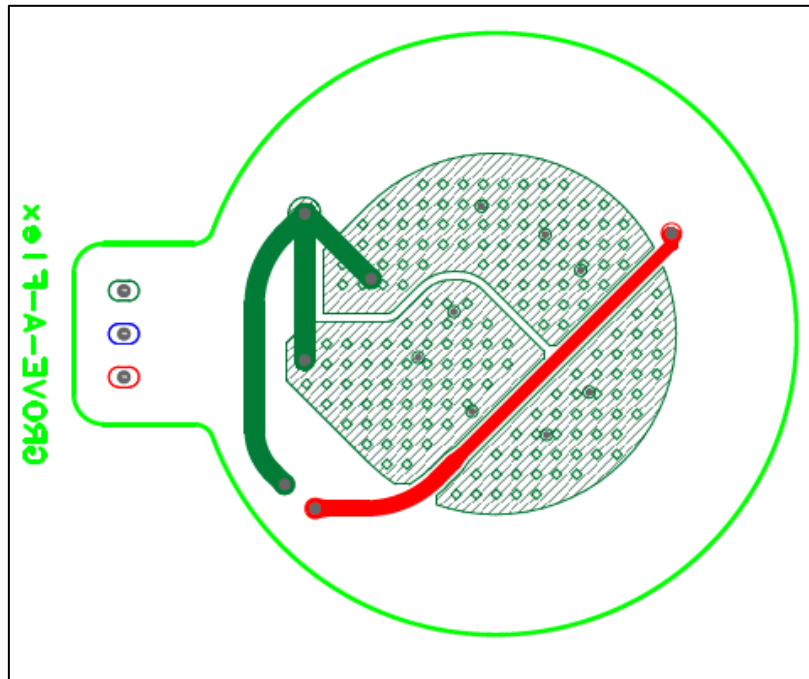

Fig. 3.8 Back surface pattern

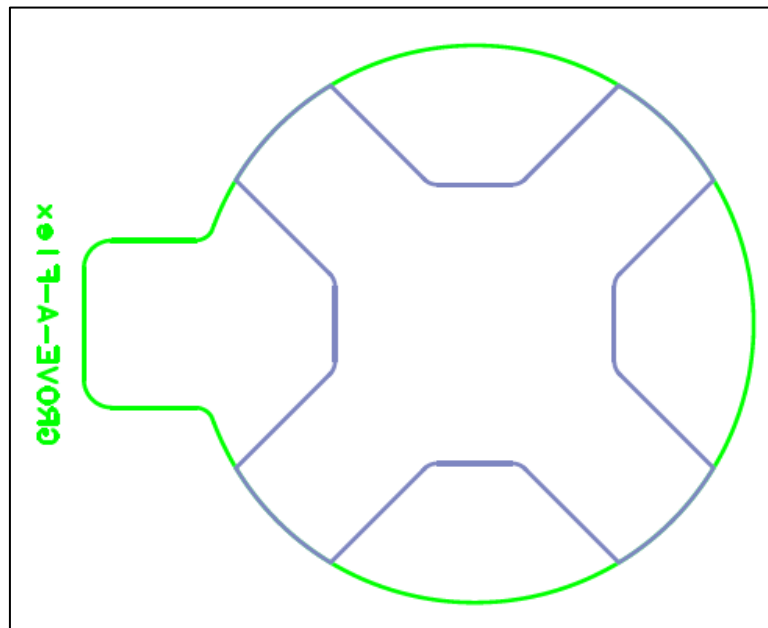

Fig. 3.9 Back surface reinforcement plate

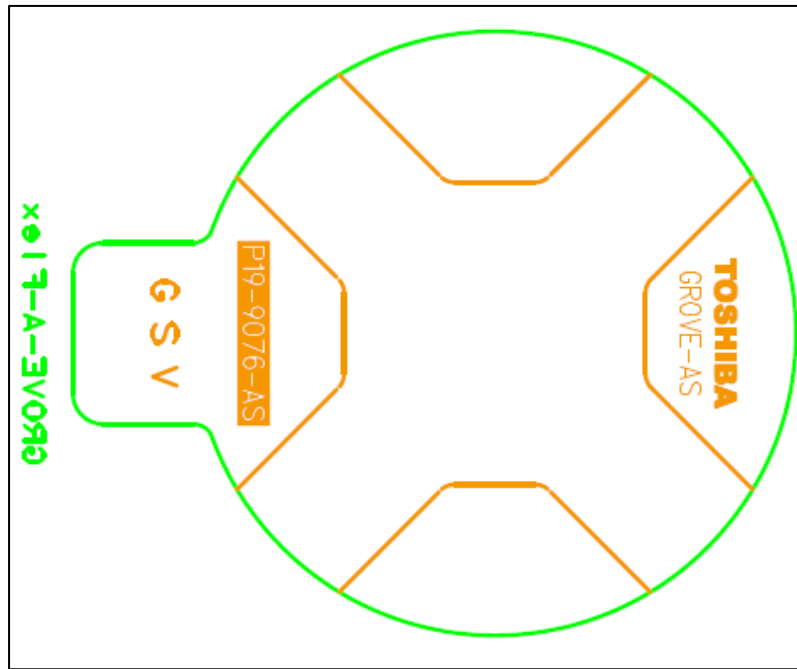

Fig. 3.10 Back surface pattern silk

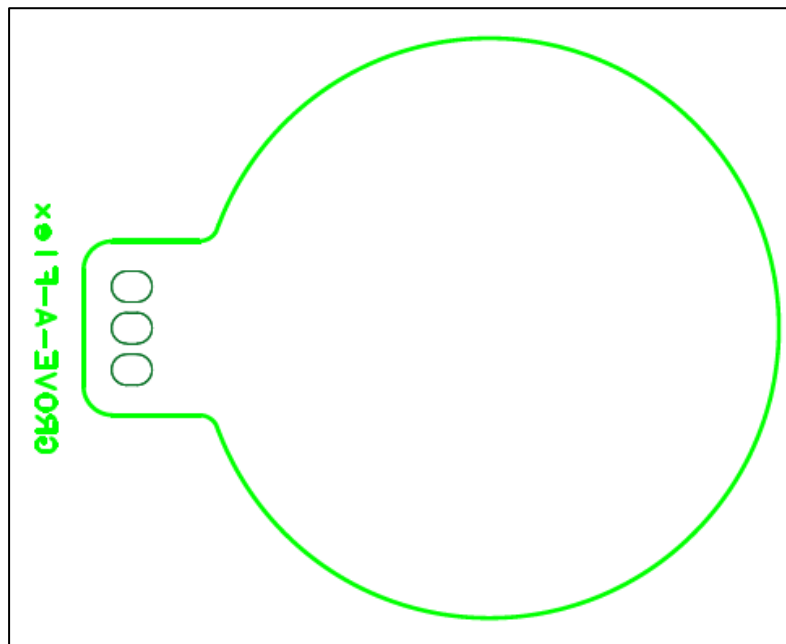

Fig. 3.11 Back surface pattern solder

## 3.5. Board pattern drawing (rigid board)

<Front (part mounting side)>

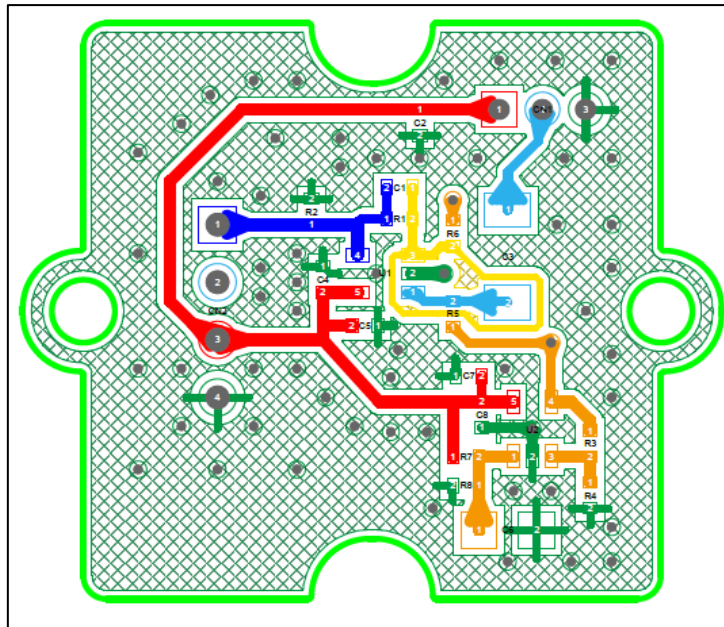

Fig. 3.12 Front surface pattern

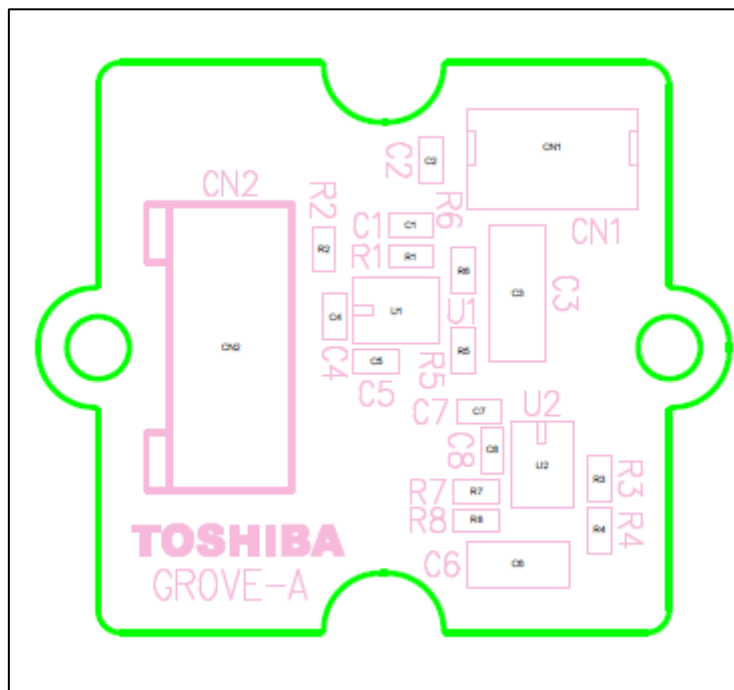

Fig. 3.13 Front surface silk

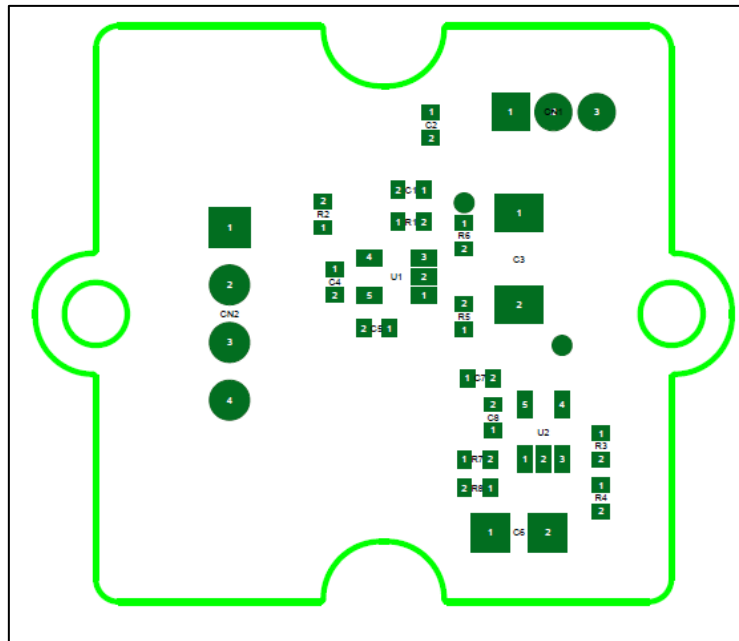
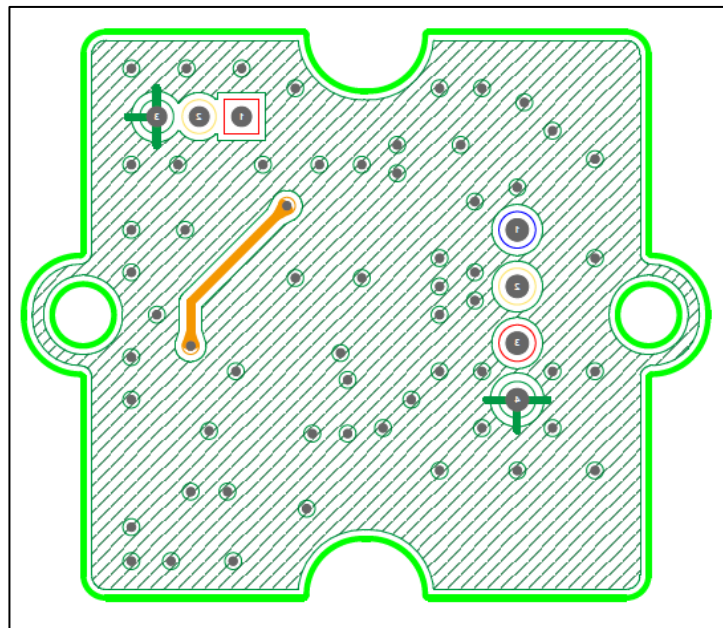
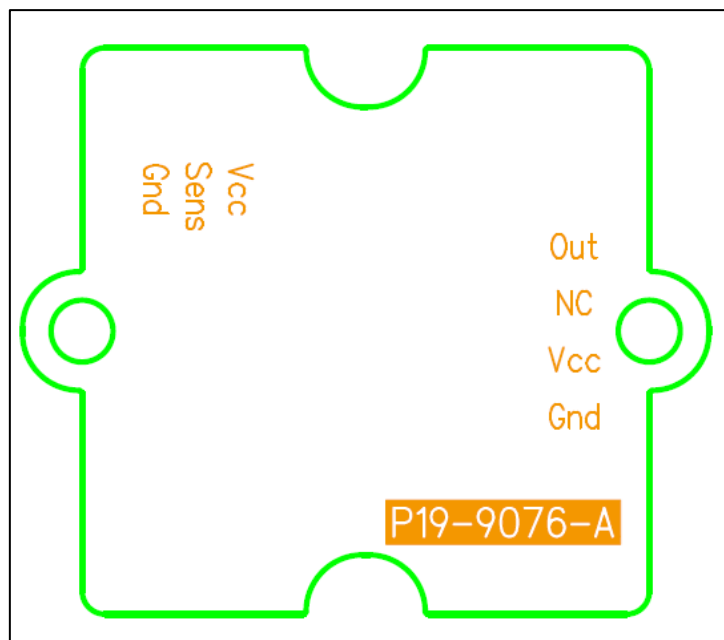

Fig. 3.14 Front surface solder

Back



**Fig. 3.15 Back surface pattern**



**Fig. 3.16 Back surface silk**



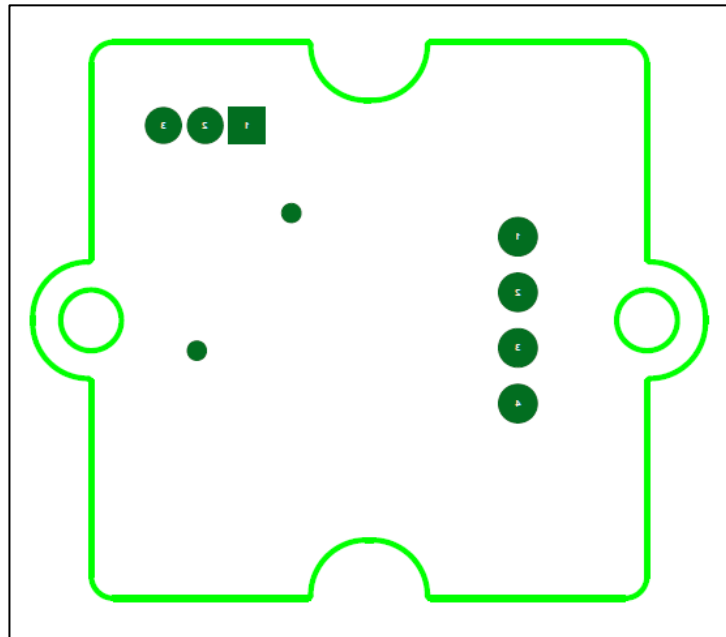

Fig. 3.17 Back surface solder

## 4. Operation procedure

### 4.1. About Arduino and Processing

The Arduino is a palm-sized one-board microcontroller. The microcontroller is selected as the control microcontroller for this reference design because it is generally available on the market and can be easily obtained, and if the program is transferred once, the sensor can be operated without a PC. Use the Processing to display the measured results on the PC-screen.

This reference design provides Arduino operating program and a Processing program that displays the status of measurements. To run this program, you must install Arduino IDE and Processing 3 on your PCs. Furthermore, In the case of pulse sensor, it is necessary to include library "MsTimer2" at Arduino IDE. Both software and library are available free of charge on their official sites. Download the software and install it on your PC in advance. These software are also needed to edit each program. These programs are called "sketches" in Arduino, Processing.

Moreover, in the case of Windows10, a display window for result of Processing may not start. In such a case, it is necessary to change the configuration file of initial value that generated automatically at the first time start-up of Processing. Since a solution change with PCs, please implement a suitable solution with reference to Web etc.

Refer to the Commercial Instructions for more information on Arduino and Processing.

### 4.2. Connecting to the Arduino

Fig. 4.1 shows the connections to the Arduino.

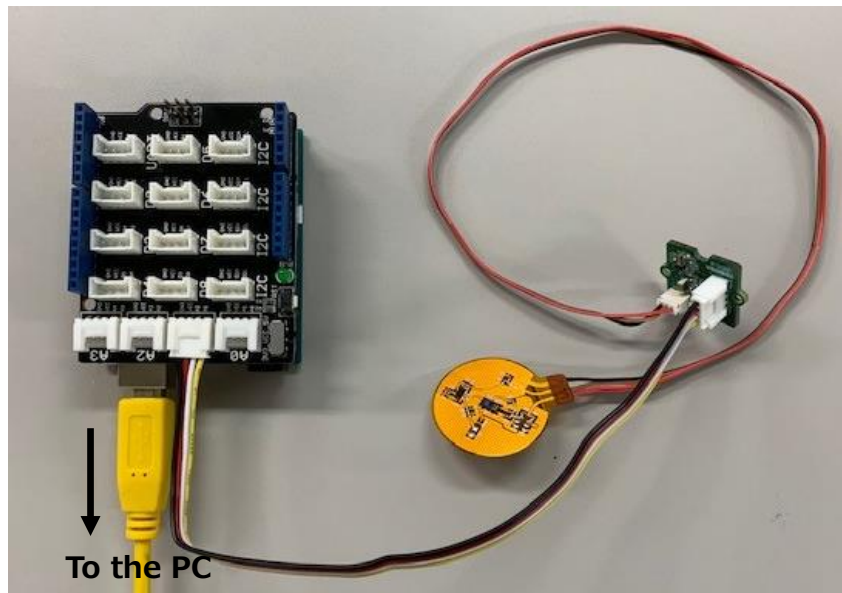

**Fig. 4.1 Connections to the Arduino**

The Arduino is used in conjunction with "seed studio Base Shield". The connection port of the base shield to the sensor is connected A1 terminal. Connect the base shield and the PC with a USB cable.

### 4.3. Start and stop

When the compressed file "RD159-SKETCH-01\_E.zip" of the sketch prepared for this sensor is downloaded from the following link and decompressed in an appropriate place on the PC, the folder containing the two files "PW\_sensor\_Arduino" and "PulseWave\_sensor.pde" and the usage convention is created. Save the file as is.

To download sketches →

[Click Here](#)

Start the Arduino IDE and select File → Open to open the saved PW\_sensor\_Arduino.ino file. The window shown on the left of Fig. 4.2 opens separately from the window opened at startup. Select Sketch → Write to the microcontroller board to start compiling the files and write the sketch to the Arduino after compiling. When writing is completed successfully, a message appears at the bottom of the window. The Arduino is now ready.

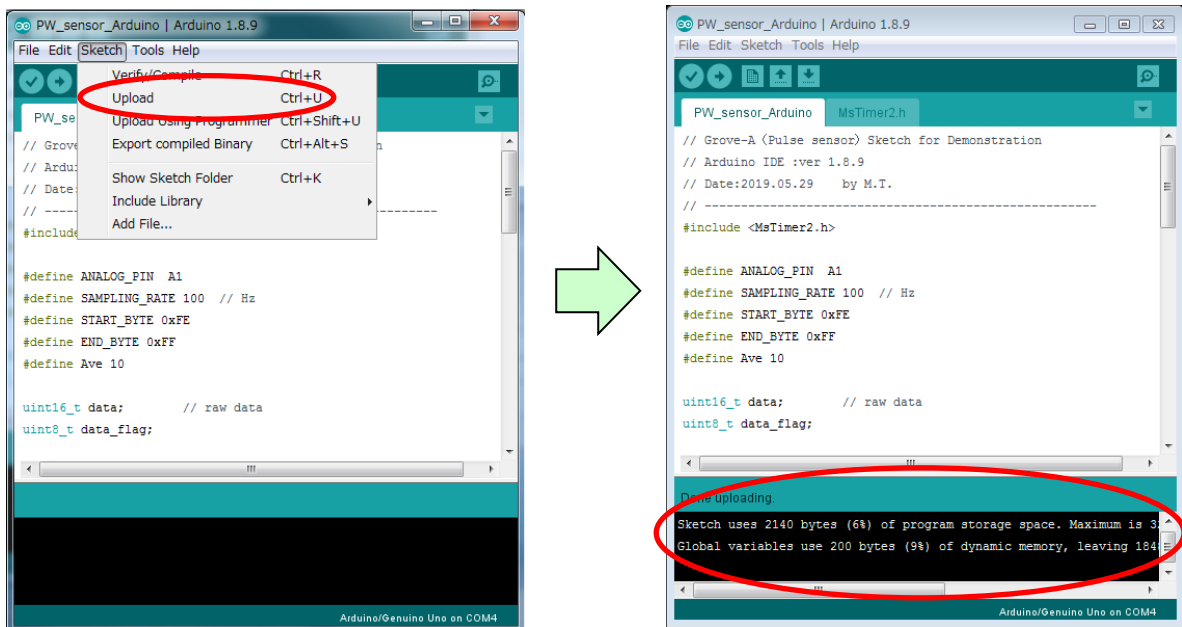

**Fig. 4.2 Arduino IDE window**

Then start the Processing 3. When you start the Processing 3, the window shown in Fig. 4.3 opens. Click Get Started at the bottom right of the child window. Then, select File → Open to open the saved PulseWave\_sensor.pde file.

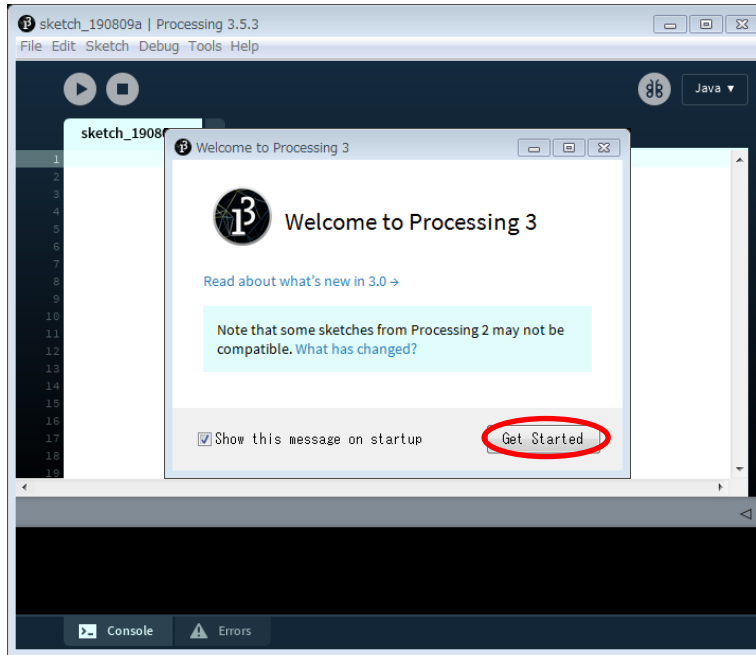

Fig. 4.3 Start-up window of Processing 3

The window shown in Figure 4.4 opens separately from the window opened at startup. Click the Operation button (red circle) to open the result display window and start the measurement.

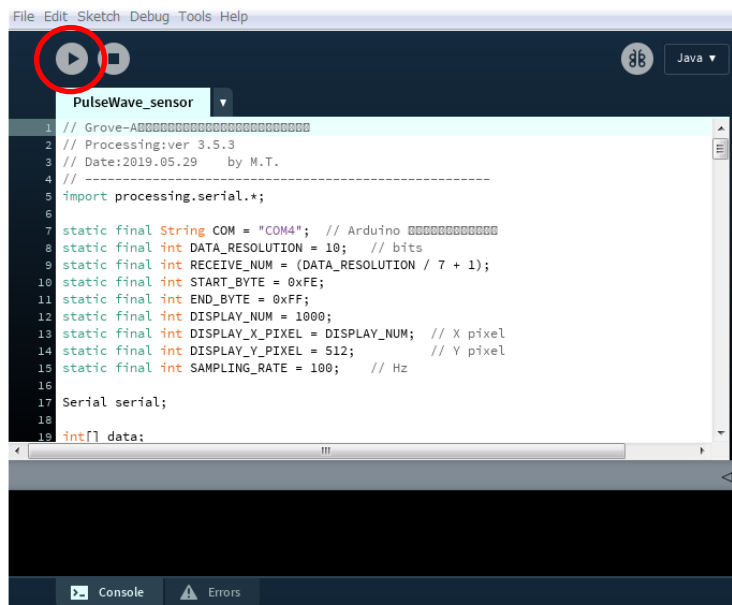
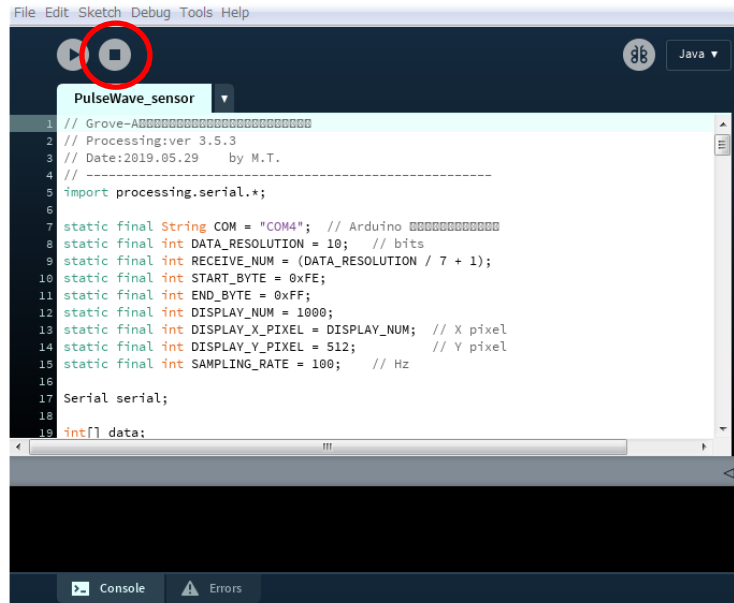

Fig. 4.4 Processing Measurement Start window

Click the stop button (red circle in Fig. 4.5) on this screen to finish the measurement. The Result View window closes and the measurement ends. Then close the open windows sequentially.



**Fig. 4.5 Processing Measurement Completion window**

You can pause the measurement by clicking on the result display window while the measurement is being performed. At this time, the result display window is not closed and the measurement waveform remains stopped. To restart the measurement, click on the window again.

#### 4.4. Precautions for measurement

- Optical sensors that detect and sense the light used in this guide are affected by disturbance light. For this reason, it is necessary to reduce the influence of disturbance light in environments such as outdoors and indoor fluorescent lights in clear weather. The sensor should be covered with a cover or housed in a housing to prevent the entry of disturbance light.
- Differences in blood vessels between individuals and their physical condition may make measurements inadequate. If this is the case, try at different locations and measure at the site where the best results are obtained.

## 5. Pulse measurement

The actual pulse measurement and the measurement status are shown below. The flexible circuit board and rigid circuit board described in this guide were housed in a special housing and used as a pulse measurement set for demonstration. Fig. 5.1 and Fig. 5.2 show the appearance.

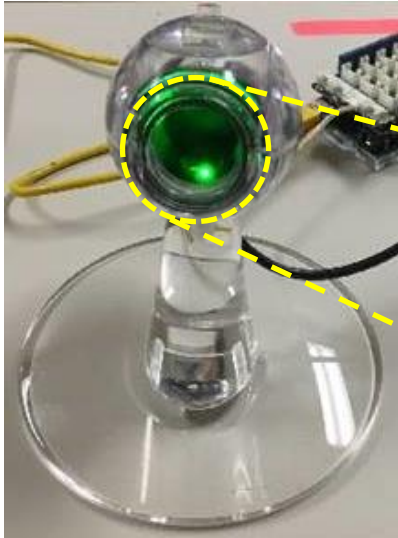

**Figure 5.1** Front view of demonstration pulse measurement set

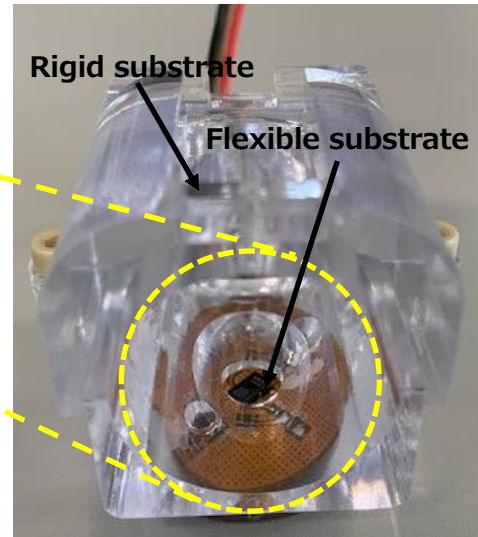

**Figure 5.2** Flexible board portion in demonstration set

Fig. 5.1 shows a front view of the demonstration pulse measurement set. This set is designed to measure the pulse with the fingertip and is measured by placing the finger in the central green-shining hole (the area enclosed by the yellow dotted circle). The green light is the light of the LEDs of the sensor.

Fig. 5.2 shows an enlargement of this hole, but it is made of transparent resin so that the mounting position of the flexible printed circuit board can be seen. In the actual set, this part is made of black resin to block light.

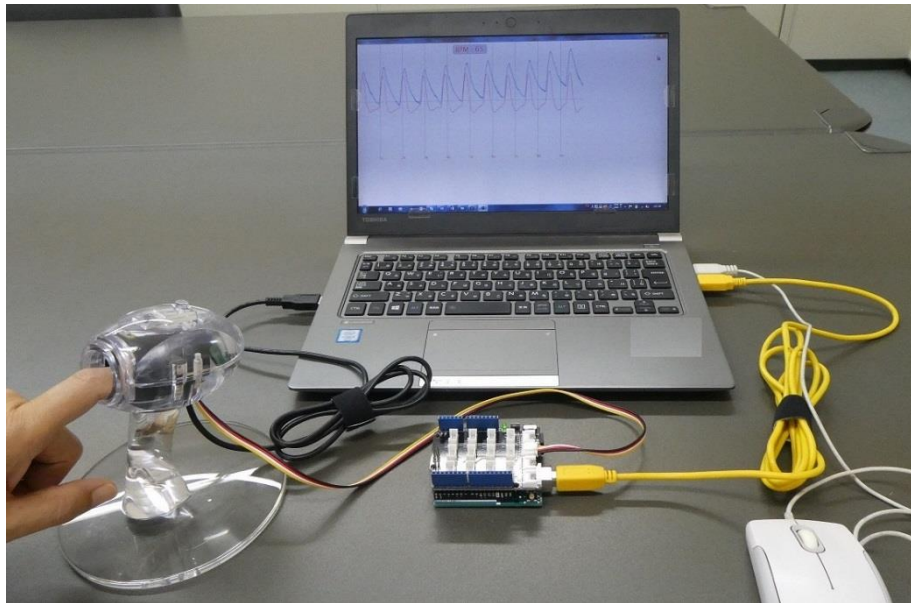

**Fig. 5.3 Example of Pulse Sensor Measurement**

Fig. 5.3 shows an example of actual pulse measurement using this set. This set is measured with fingertips, but it can also be measured at other parts of the body, such as the wrist, with a different housing.

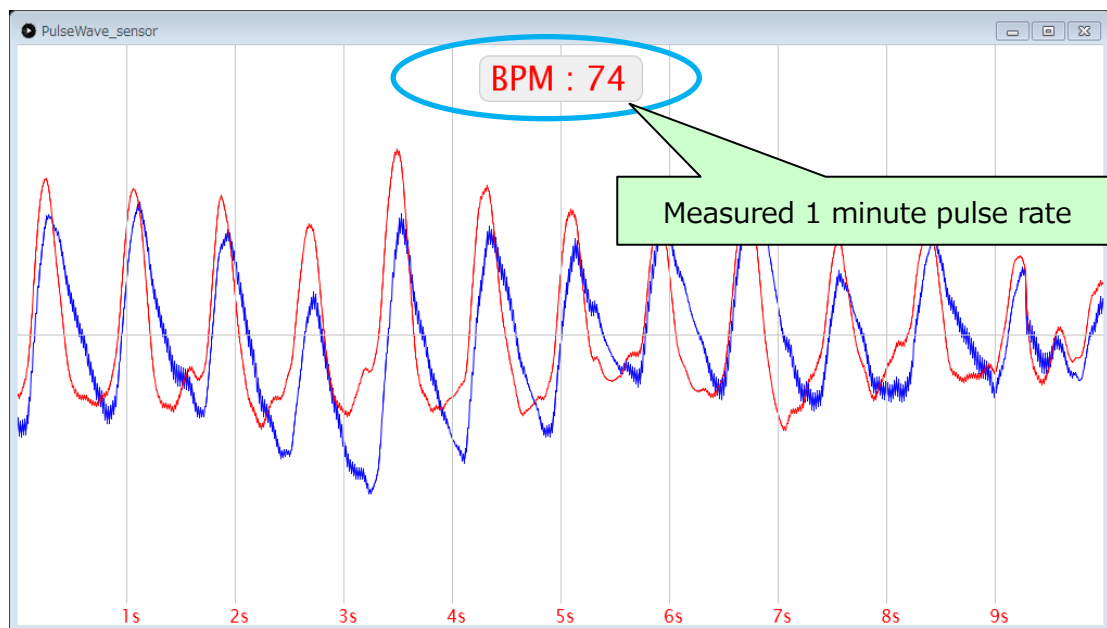

**Figure 5.2 Waveform of Pulse Sensor Measurement status**

Figure 5.4 shows an example of the results display screen. The blue line is the measured actual pulse wave, and the red line is the pulse wave that is filtered and shaped for measurement. The pulse rate is converted to a one-minute number from the period of this waveform and displayed in the upper part of the Measure window as the BPM (Beats Per Minute) value.

## Terms of Use

This terms of use is made between Toshiba Electronic Devices and Storage Corporation ("We") and customers who use documents and data that are consulted to design electronics applications on which our semiconductor devices are mounted ("this Reference Design"). Customers shall comply with this terms of use. Please note that it is assumed that customers agree to any and all this terms of use if customers download this Reference Design. We may, at its sole and exclusive discretion, change, alter, modify, add, and/or remove any part of this terms of use at any time without any prior notice. We may terminate this terms of use at any time and for any reason. Upon termination of this terms of use, customers shall destroy this Reference Design. In the event of any breach thereof by customers, customers shall destroy this Reference Design, and furnish us a written confirmation to prove such destruction.

### 1. Restrictions on usage

1. This Reference Design is provided solely as reference data for designing electronics applications. Customers shall not use this Reference Design for any other purpose, including without limitation, verification of reliability.
2. This Reference Design is for customer's own use and not for sale, lease or other transfer.
3. Customers shall not use this Reference Design for evaluation in high or low temperature, high humidity, or high electromagnetic environments.
4. This Reference Design shall not be used for or incorporated into any products or systems whose manufacture, use, or sale is prohibited under any applicable laws or regulations.

### 2. Limitations

1. We reserve the right to make changes to this Reference Design without notice.
2. This Reference Design should be treated as a reference only. We are not responsible for any incorrect or incomplete data and information.
3. Semiconductor devices can malfunction or fail. When designing electronics applications by referring to this Reference Design, customers are responsible for complying with safety standards and for providing adequate designs and safeguards for their hardware, software and systems which minimize risk and avoid situations in which a malfunction or failure of semiconductor devices could cause loss of human life, bodily injury or damage to property, including data loss or corruption. Customers must also refer to and comply with the latest versions of all relevant our information, including without limitation, specifications, data sheets and application notes for semiconductor devices, as well as the precautions and conditions set forth in the "Semiconductor Reliability Handbook".
4. When designing electronics applications by referring to this Reference Design, customers must evaluate the whole system adequately. Customers are solely responsible for all aspects of their own product design or applications. WE ASSUME NO LIABILITY FOR CUSTOMERS' PRODUCT DESIGN OR APPLICATIONS.
5. No responsibility is assumed by us for any infringement of patents or any other intellectual property rights of third parties that may result from the use of this Reference Design. No license to any intellectual property right is granted by this terms of use, whether express or implied, by estoppel or otherwise.
6. THIS REFERENCE DESIGN IS PROVIDED "AS IS". WE (a) ASSUME NO LIABILITY WHATSOEVER, INCLUDING WITHOUT LIMITATION, INDIRECT, CONSEQUENTIAL, SPECIAL, OR INCIDENTAL DAMAGES OR LOSS, INCLUDING WITHOUT LIMITATION, LOSS OF PROFITS, LOSS OF OPPORTUNITIES, BUSINESS INTERRUPTION AND LOSS OF DATA, AND (b) DISCLAIM ANY AND ALL EXPRESS OR IMPLIED WARRANTIES AND CONDITIONS RELATED TO THIS REFERENCE DESIGN, INCLUDING WARRANTIES OR CONDITIONS OF MERCHANTABILITY, FITNESS FOR A PARTICULAR PURPOSE, ACCURACY OF INFORMATION, OR NONINFRINGEMENT.

### 3. Export Control

Customers shall not use or otherwise make available this Reference Design for any military purposes, including without limitation, for the design, development, use, stockpiling or manufacturing of nuclear, chemical, or biological weapons or missile technology products (mass destruction weapons). This Reference Design may be controlled under the applicable export laws and regulations including, without limitation, the Japanese Foreign Exchange and Foreign Trade Law and the U.S. Export Administration Regulations. Export and re-export of this Reference Design are strictly prohibited except in compliance with all applicable export laws and regulations.

### 4. Governing Laws

This terms of use shall be governed and construed by laws of Japan.