

FIBER OPTIC TRANSMITTING MODULE

TOTX1350(V,F)

GENERAL PURPOSE OPTICAL TRANSMITTING MODULE

- JIS F05 type fiber optic connector
- 650 nm LED
- Low current LED drive
- Vertical mounting type

1. Absolute Maximum Ratings (Ta = 25°C)

Characteristics	Symbol	Rating	Unit
Storage Temperature	T _{stg}	-40 to 95	°C
Operating Temperature	T _{opr}	-40 to 85	°C
Forward Current (DC)	I _{FDC}	30	mA
Reverse Voltage	V _R	5	V
Soldering Temperature	T _{sol}	260 (Note 1)	°C

Note 1: Soldering time ≤ 10 s (More than 1 mm apart from the package).

Using continuously under heavy loads (e.g. the application of high temperature/current/voltage and the significant change in temperature, etc.) may cause this product to decrease in the reliability significantly even if the operating conditions (i.e. operating temperature/ current/ voltage, etc.) are within the absolute maximum ratings. Please design the appropriate reliability upon reviewing the Toshiba Semiconductor Reliability Handbook ("Handling Precautions"/ "Derating Concept and Methods") and individual reliability data (i.e. reliability test report and estimated failure rate, etc.).

2. Operating Ranges

Characteristics	Symbol	Min	Typ.	Max	Unit
Forward Current (DC)	I _F	-	6	8	mA
Data Rate		DC	-	10	Mb / s

Start of commercial production
2013-11

3. Electrical and Optical Characteristics (Ta = 25°C, Vcc = 5 V)

Characteristics	Symbol	Test Condition	Min	Typ.	Max	Unit
Data Rate (Note 2)		NRZ Code	DC	-	10	Mb / s
Transmission Distance (Note 2)		APF (Note 3), IF = 6 mA, Using TORX1350A(V,F)	40	-	100	m
		APF (Note 3), IF = 1.5 mA, Using TORX1350A(V,F)	0.2	-	50	m
		APF (Note 3), IF = 6 mA, Using TORX1355(V,F)	0.2	-	10	m
Transmission Distance (Note 2), (Note 4)		IF = 6 mA, Using TORX1350A(V,F) and TOCA1300	-	23.6	-	mm
		IF = 6 mA, Using TORX1355(V,F) and TOCA1300	-	23.6	-	mm
		IF = 6 mA, Using TORX1350A(V,F) and TOCA1301	-	34.0	-	mm
		IF = 6 mA, Using TORX1355(V,F) and TOCA1301	-	34.0	-	mm
Pulse Width Distortion (Note 5)	Δtw		-30	-	30	%
Fiber Output Power (Note 6)	P _f	IF = 6 mA, APF (Note3),	-6	-	-2	dBm
		IF = 1.5 mA, APF (Note3),	-13	-	-8	dBm
Center Emission Wavelength	λ_c		-	650	-	nm
Forward Voltage	V _F	IF = 6 mA	-	2.0	2.1	V
		IF = 1.5 mA	-	1.8	2.0	V
Reverse Current	IR	VR = 5 V	-	-	10	μ A

Note 2: Use the drive circuit of Chapter 4.

Note 3: All Plastic Fiber (980 μ m core / 1000 μ m cladding, NA = 0.5). Polished surface.
Transmission loss is less than 0.18 dB/m. (100m @650nm).

Note 4: A distance between fixing pin of TOTX1350(V,F) and fixing pin of TORX1350A(V,F) or TORX1355(V,F) when they connect with optical adapter (TOCA1300 or TOCA1301).

Note 5: Between input of driver circuit of TOTX1350(V,F) and output of TORX1350A(V,F) or TORX1355(V,F).
Use the drive circuit of Chapter 4.

Note 6: Measure with a standard optical fiber with fiber optic connectors. Valued by peak.

Not Recommended for New

4. Application Circuit

(1) $I_F = 6\text{mA}$ operation, Using TORX1350A(V,F)

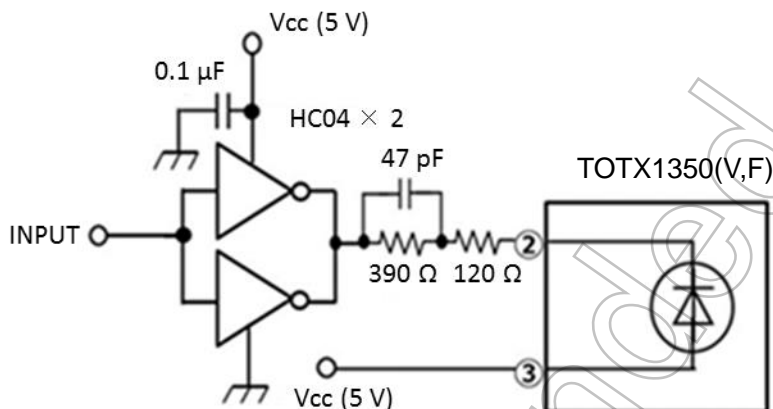

Replace 47 pF of capacitor with 82 pF if need a smaller jitter.

(2) $I_F = 1.5\text{mA}$ operation, Using TORX1350A(V,F)

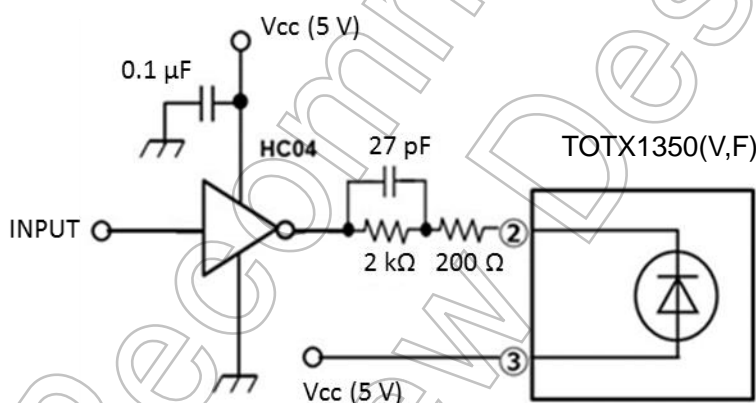

(3) $I_F = 4\text{mA}$ operation, Using TORX1355(V,F)

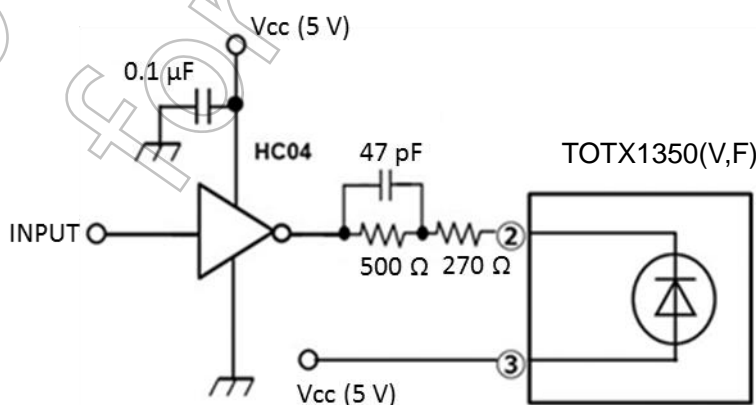

(4) $I_F = 6 \text{ mA}$ operation, Using TOCA1300 or TOCA1301

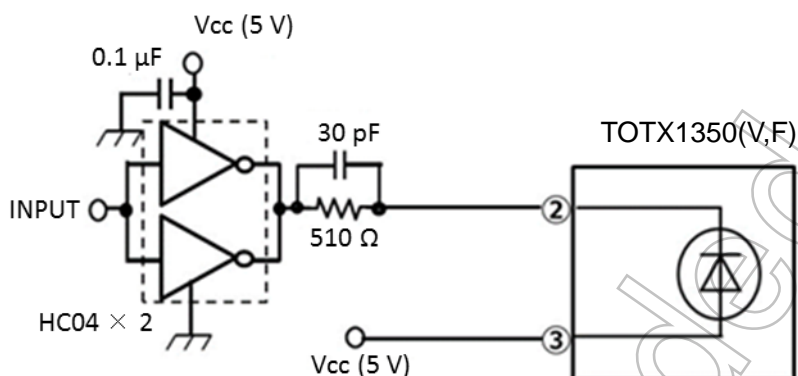

5. Applicable Optical Fiber with Fiber Optic Connectors

All Plastic Fiber (980 μm core / 1000 μm cladding, NA = 0,5) with F05 type optical connector. Polished surface. Transmission loss is less than 0.18 dB/m. (100m @650nm).

6. Applicable Optical Adapters

TOCA1300, TOCA1301

7. Precautions during use

(1) Absolute maximum rating

The absolute maximum ratings are the limit values which must not be exceeded during operation of device. Any rating value must not be exceeded. If the absolute maximum rating value is exceeded, the characteristics of devices may never be restored properly. In extreme cases, the device may be permanently damaged.

(2) Operating Range

The operating range is the range of conditions necessary for the device to operate as specified in individual technical datasheets and databooks. Care must be exercised in the design of the equipment. If a device is used under conditions that do not exceed absolute maximum ratings but exceed the operating range, the specifications related to device operation and electrical characteristics may not be met, resulting in a decrease in reliability.

If greater reliability is required, derate the device's operating ranges for voltage, current, power and temperature before use.

(3) Lifetime of light emitters

If an optical module is used for a long period of time, degeneration in the characteristics will mostly be due to a lowering of the fiber output power (Pf). This is caused by the degradation of the optical output of the LEDs used as the light source. The cause of degradation of the optical output of the LEDs may be defects in wafer crystallization or mold resin stress. The detailed causes are, however, not clear.

The lifetime of light emitters is greatly influenced by the operating conditions and the environment in which they are used as well as by the lifetime characteristics unique to the device type. Thus, when a light emitting device and its operating conditions determined, Toshiba recommends that lifetime characteristics be checked.

Depending on the environment conditions, Toshiba recommends the maintenance such as regular checks of the amount of optical output in accordance with the condition of operating environment.

(4) Soldering

Optical modules are comprised of internal semiconductor devices. However, in principle, optical modules are optical components. During soldering, ensure that flux does not contact with the emitting surface or the detecting surface. Also ensure that proper flux removal is conducted after soldering.

This optical module comes with a protective cap. The protective cap is used to avoid malfunction when the optical module is not in use. Note that it is not dust or waterproof.

As mentioned before, optical modules are optical components. Thus, in principle, soldering where there may be flux residue and flux removal after soldering are not recommended. Toshiba recommends that soldering be performed without the optical module mounted on the board. Then, after the board has been cleaned, the optical module should be soldered on to the board manually.

If the optical module cannot be soldered manually, use non-halogen (chlorine-free) flux and make sure, without cleaning, there is no residue such as chlorine.

(5) Vibration and shock

This module is plastic sealed and has its wire fixed by resin. This structure is relatively resistant to vibration and shock. In actual equipment, there are sometime cases in which vibration, shock, or stress is applied to soldered parts or connected parts, resulting in lines cut. A care must be taken in the design of equipment which will be subject to high levels of vibration.

(6) Fixing fiber optical transmitting module

Solder the fixing pin (pins 4 and 5) of fiber optic transmitting module TOTX1350(V,F) to the printed circuit board to fix the module to the board.

(7) Solvent

When using solvent for flux removal, do not use a high acid or high alkali solvent. Be careful not to pour solvent into the optical connector ports. If solvent is inadvertently poured into them, clean it off using cotton tips.

(8) Protective cap

When the TOTX1350(V,F) is not in use, attach the protective cap.

(9) An influence of flash or strong light

Do not emit a flash or a strong light to the optical module directly they may cause an error in data transmission.

(10) Soldering condition

Solder at 260°C or less for no more than ten seconds.

(11) Precautions when disposing of devices and packing materials.

When disposing devices and packing materials, follow the procedures stipulated by local regulations in order to protect the environment against contamination.

(12) Others

This product is an optical transmitting module for plastic optical fiber.

Use only for an optical transmitting module purpose.

8. Package Outline drawing

Unit: mm

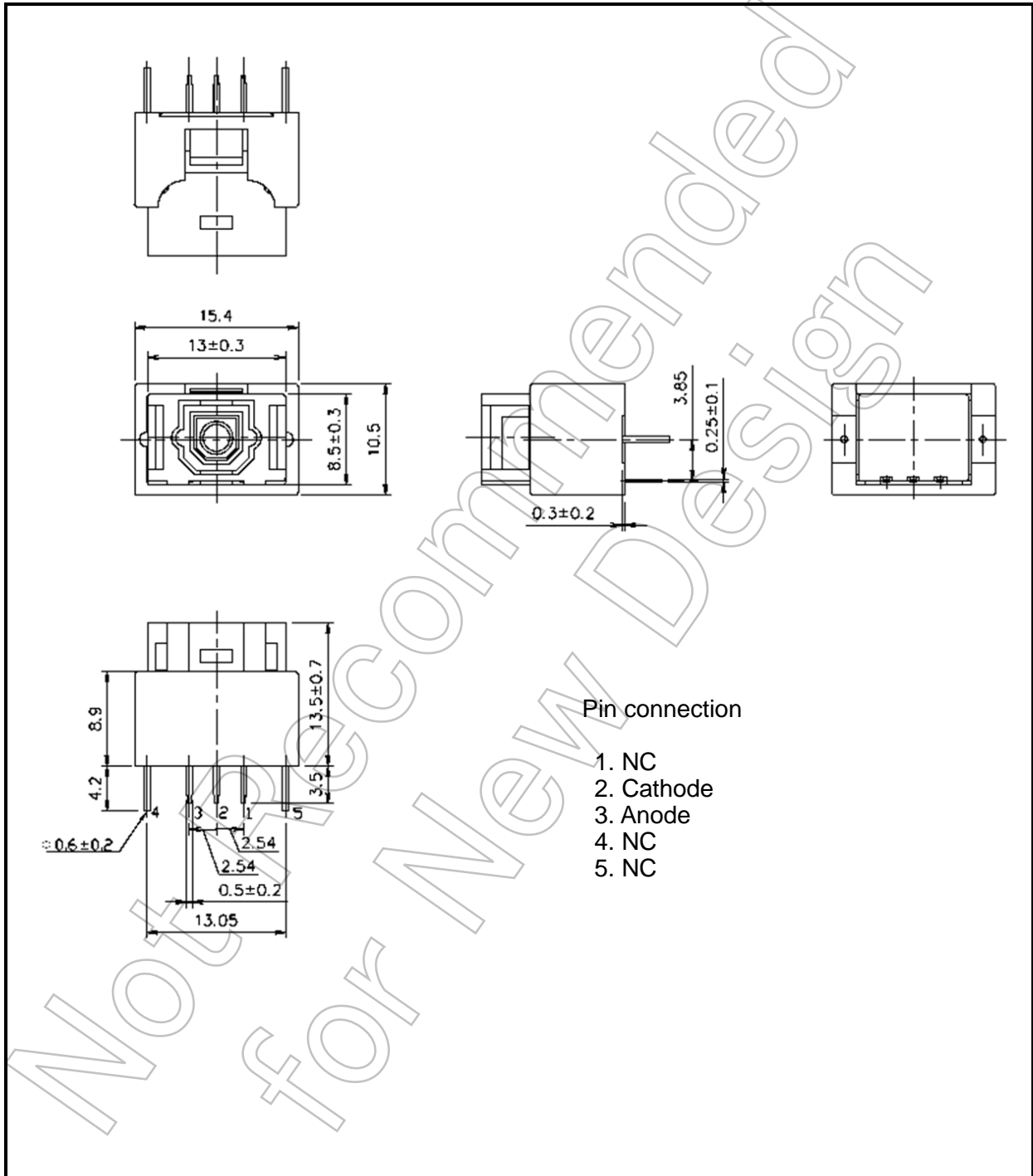

Weight: 2.4 g (typ.)

RESTRICTIONS ON PRODUCT USE

Toshiba Corporation and its subsidiaries and affiliates are collectively referred to as "TOSHIBA".

Hardware, software and systems described in this document are collectively referred to as "Product".

- TOSHIBA reserves the right to make changes to the information in this document and related Product without notice.
- This document and any information herein may not be reproduced without prior written permission from TOSHIBA. Even with TOSHIBA's written permission, reproduction is permissible only if reproduction is without alteration/omission.
- Though TOSHIBA works continually to improve Product's quality and reliability, Product can malfunction or fail. Customers are responsible for complying with safety standards and for providing adequate designs and safeguards for their hardware, software and systems which minimize risk and avoid situations in which a malfunction or failure of Product could cause loss of human life, bodily injury or damage to property, including data loss or corruption. Before customers use the Product, create designs including the Product, or incorporate the Product into their own applications, customers must also refer to and comply with (a) the latest versions of all relevant TOSHIBA information, including without limitation, this document, the specifications, the data sheets and application notes for Product and the precautions and conditions set forth in the "TOSHIBA Semiconductor Reliability Handbook" and (b) the instructions for the application with which the Product will be used with or for. Customers are solely responsible for all aspects of their own product design or applications, including but not limited to (a) determining the appropriateness of the use of this Product in such design or applications; (b) evaluating and determining the applicability of any information contained in this document, or in charts, diagrams, programs, algorithms, sample application circuits, or any other referenced documents; and (c) validating all operating parameters for such designs and applications. **TOSHIBA ASSUMES NO LIABILITY FOR CUSTOMERS' PRODUCT DESIGN OR APPLICATIONS.**
- **PRODUCT IS NEITHER INTENDED NOR WARRANTED FOR USE IN EQUIPMENTS OR SYSTEMS THAT REQUIRE EXTRAORDINARILY HIGH LEVELS OF QUALITY AND/OR RELIABILITY, AND/OR A MALFUNCTION OR FAILURE OF WHICH MAY CAUSE LOSS OF HUMAN LIFE, BODILY INJURY, SERIOUS PROPERTY DAMAGE AND/OR SERIOUS PUBLIC IMPACT ("UNINTENDED USE").** Except for specific applications as expressly stated in this document, Unintended Use includes, without limitation, equipment used in nuclear facilities, equipment used in the aerospace industry, lifesaving and/or life supporting medical equipment, equipment used for automobiles, trains, ships and other transportation, traffic signaling equipment, equipment used to control combustions or explosions, safety devices, elevators and escalators, and devices related to power plant. **IF YOU USE PRODUCT FOR UNINTENDED USE, TOSHIBA ASSUMES NO LIABILITY FOR PRODUCT.** For details, please contact your TOSHIBA sales representative or contact us via our website.
- Do not disassemble, analyze, reverse-engineer, alter, modify, translate or copy Product, whether in whole or in part.
- Product shall not be used for or incorporated into any products or systems whose manufacture, use, or sale is prohibited under any applicable laws or regulations.
- The information contained herein is presented only as guidance for Product use. No responsibility is assumed by TOSHIBA for any infringement of patents or any other intellectual property rights of third parties that may result from the use of Product. No license to any intellectual property right is granted by this document, whether express or implied, by estoppel or otherwise.
- **ABSENT A WRITTEN SIGNED AGREEMENT, EXCEPT AS PROVIDED IN THE RELEVANT TERMS AND CONDITIONS OF SALE FOR PRODUCT, AND TO THE MAXIMUM EXTENT ALLOWABLE BY LAW, TOSHIBA (1) ASSUMES NO LIABILITY WHATSOEVER, INCLUDING WITHOUT LIMITATION, INDIRECT, CONSEQUENTIAL, SPECIAL, OR INCIDENTAL DAMAGES OR LOSS, INCLUDING WITHOUT LIMITATION, LOSS OF PROFITS, LOSS OF OPPORTUNITIES, BUSINESS INTERRUPTION AND LOSS OF DATA, AND (2) DISCLAIMS ANY AND ALL EXPRESS OR IMPLIED WARRANTIES AND CONDITIONS RELATED TO SALE, USE OF PRODUCT, OR INFORMATION, INCLUDING WARRANTIES OR CONDITIONS OF MERCHANTABILITY, FITNESS FOR A PARTICULAR PURPOSE, ACCURACY OF INFORMATION, OR NONINFRINGEMENT.**
- GaAs (Gallium Arsenide) is used in Product. GaAs is harmful to humans if consumed or absorbed, whether in the form of dust or vapor. Handle with care and do not break, cut, crush, grind, dissolve chemically or otherwise expose GaAs in Product.
- Do not use or otherwise make available Product or related software or technology for any military purposes, including without limitation, for the design, development, use, stockpiling or manufacturing of nuclear, chemical, or biological weapons or missile technology products (mass destruction weapons). Product and related software and technology may be controlled under the applicable export laws and regulations including, without limitation, the Japanese Foreign Exchange and Foreign Trade Law and the U.S. Export Administration Regulations. Export and re-export of Product or related software or technology are strictly prohibited except in compliance with all applicable export laws and regulations.
- Please contact your TOSHIBA sales representative for details as to environmental matters such as the RoHS compatibility of Product. Please use Product in compliance with all applicable laws and regulations that regulate the inclusion or use of controlled substances, including without limitation, the EU RoHS Directive. **TOSHIBA ASSUMES NO LIABILITY FOR DAMAGES OR LOSSES OCCURRING AS A RESULT OF NONCOMPLIANCE WITH APPLICABLE LAWS AND REGULATIONS.**

TOSHIBA ELECTRONIC DEVICES & STORAGE CORPORATION

<https://toshiba.semicon-storage.com/>