

TB62269FTG

PWM method CLK-IN bipolar stepping motor driver

The TB62269FTG is a two-phase bipolar stepping motor driver using a PWM chopper. Fabricated with the BiCD process, the TB62269FTG is rated at 40 V/1.8 A. The internal voltage regulator allows control of the motor with a single VM power supply.

Features

- Drive control is possible in a bipolar stepping motor at 1 chip.
- PWM controlled constant-current drive
- Allows full, half and quarter, 1/8, 1/16, 1/32 step resolutions.
- Low on-resistance of output stage transistor is low by using BiCD process.
- High Voltage and current (For specification, please refer to absolute maximum ratings and operation ranges)
- Thermal shutdown (TSD), over-current shutdown (ISD), and power-on reset of VM power supply (POR)
- Built-in regulator allows the TB62269FTG to function with only VM power supply.
- Able to customize PWM signal frequency by external resistance/capacitor.
- Packages TB62269FTG : (P-WQFN48-0707-0.50-003)

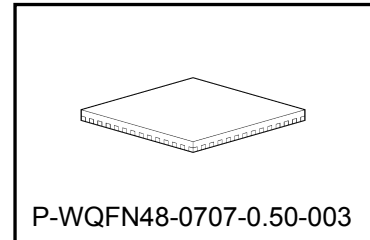

Weight:0.14g(Typ.)

Note) Please be careful about thermal conditions during use.

Pin assignment

(Top View)

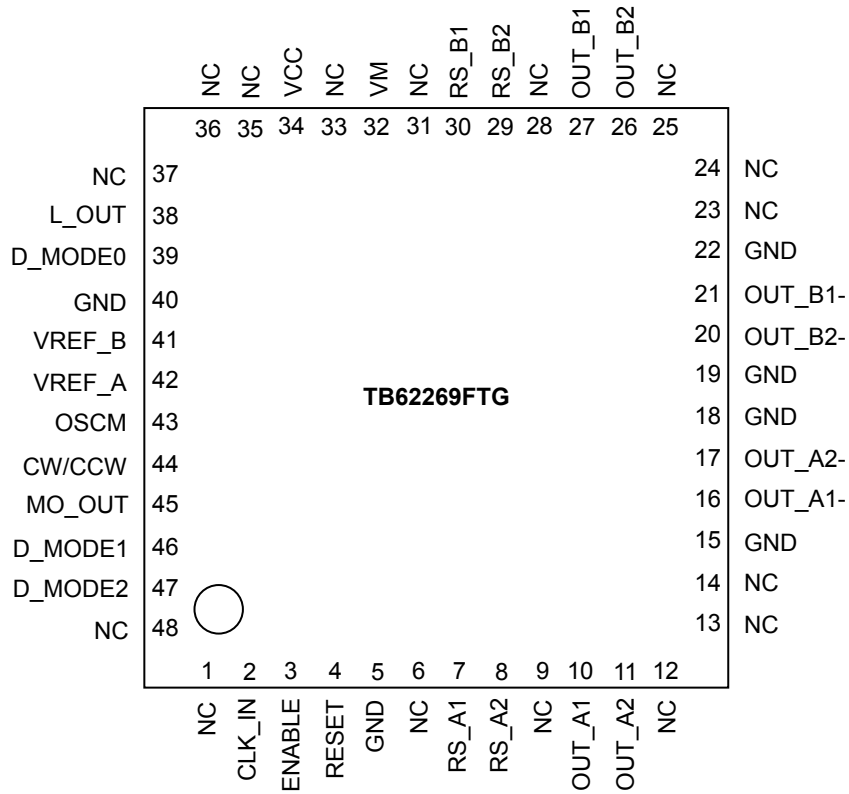

※ Please mount the four corner pins of the QFN package and the exposed pad to the GND area of the PCB.

Block Diagram

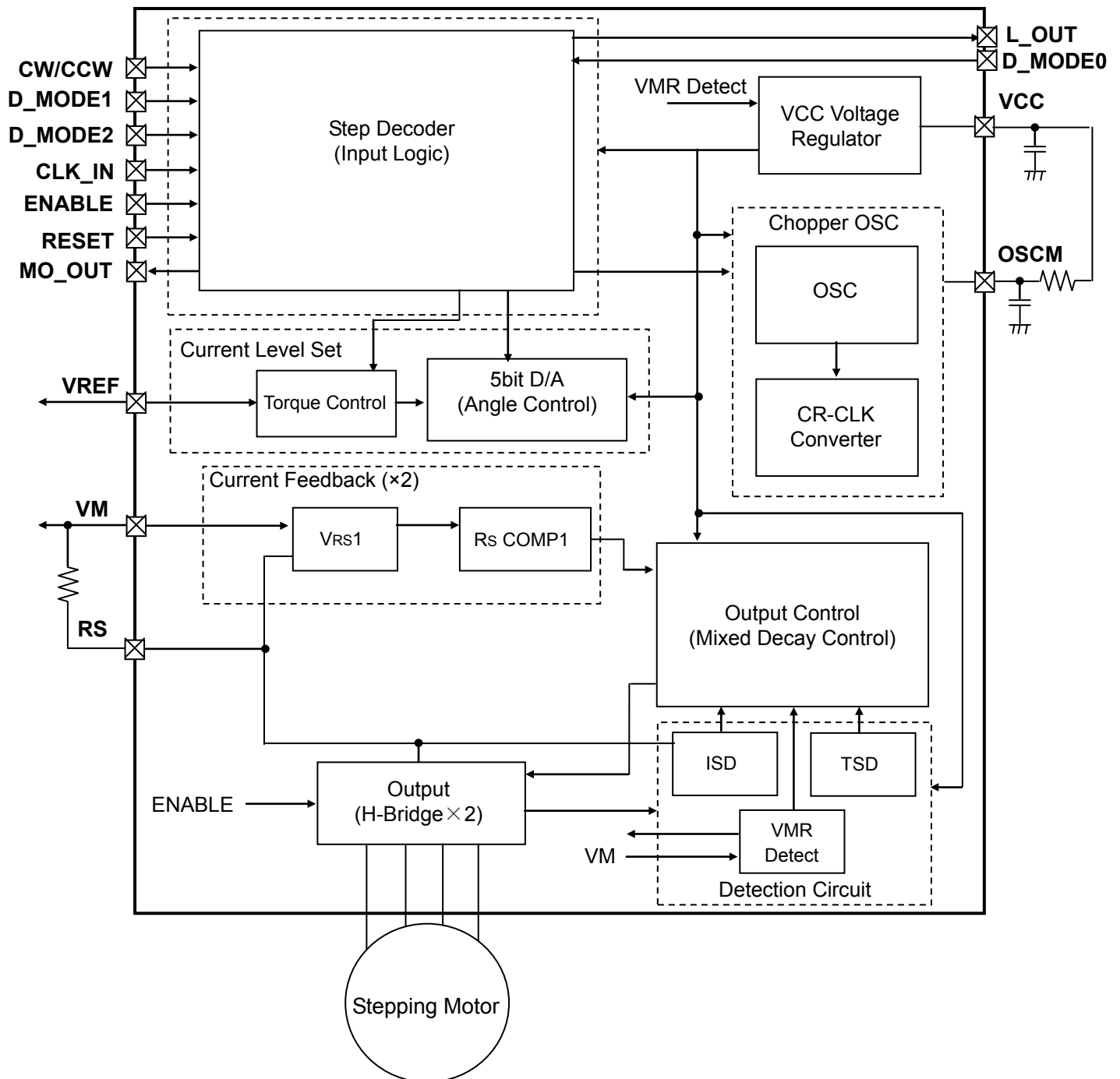

Functional blocks/circuits/constants in the block chart etc. may be omitted or simplified for explanatory purposes.

Application Notes

All the grounding wires of the TB62269FTG must run on the solder mask on the PCB and be externally terminated at only one point. Also, a grounding method should be considered for efficient heat dissipation. Careful attention should be paid to the layout of the output, VDD (VM) and GND traces, to avoid short circuits across output pins or to the power supply or ground. If such a short circuit occurs, the TB62269FTG may be permanently damaged.

Also, the utmost care should be taken for pattern designing and implementation of the TB62269FTG since it has power supply pins (VM, RS, OUT, GND) through which a particularly large current may run. If these pins are wired incorrectly, an operation error may occur or the TB62269FTG may be destroyed.

The logic input pins must also be wired correctly. Otherwise, the TB62269FTG may be damaged owing to a current running through the IC that is larger than the specified current.

Pin Function

TB62269FTG (QFN48)

Function explanation of terminal number 1 to 48

Pin No.	Pin Name	Function	Pin No.	Pin Name	Function
1	NC	No-connect	25	NC	No-connect
2	CLK_IN	An electrical angle leads on the rising edge of the clock input. A motor rotation count depends on the input frequency.	26	OUT_B2*	Bch positive driver output
3	ENABLE	A/B channel output enable	27	OUT_B1*	
4	RESET	Electric angle reset	28	NC	No-connect
5	GND	Logic ground	29	RS_B2*	Motor Bch current sense pin
6	NC	No-connect	30	RS_B1*	
7	RS_A1*	Motor Ach current sense pin	31	NC	No-connect
8	RS_A2*		32	VM	Motor Power supply
9	NC	No-connect	33	NC	No-connect
10	OUT_A1*	Ach positive driver output	34	VCC	Internal VCC regulator monitor pin
11	OUT_A2*		35	NC	No-connect
12	NC	No-connect	36	NC	No-connect
13	NC	No-connect	37	NC	No-connect
14	NC	No-connect	38	L_OUT	Error detect signal output
15	GND	Motor power ground	39	D_MODE0	Step resolution mode control 0
16	OUT_A1-*	Ach negative driver output	40	GND	Logic ground
17	OUT_A2-*		41	VREF_B	Tunes the current level for Bch motor drive.
18	GND	Motor power ground	42	VREF_A	Tunes the current level for Ach motor drive.
19	GND	Motor power ground	43	OSCM	Oscillator pin for PWM chopper
20	OUT_B2-*	Bch negative driver output	44	CW/CCW	Motor rotation: forward/reverse
21	OUT_B1-*		45	MO_OUT	Electric angle monitor
22	GND	Motor power ground	46	D_MODE1	Step resolution mode control 1
23	NC	No-connect	47	D_MODE2	Step resolution mode control 2
24	NC	No-connect	48	NC	No-connect

• Please use the pin of NC with Open.

*Please connect the pins with the same names, at the nearest point of the device.

CLK Function

The electrical angle leads one by one in the manner of the clocks. The clock signal is reflected to the electrical angle on the rising edge.

CLK Input	Function
Rise	The electrical angle leads one by one on the rising edge.
Fall	Remains at the same position.

ENABLE Function

The ENABLE pin controls whether the current is allowed to flow through a given phase for a stepper motor drive. This pin selects whether the motor is stopped in Off mode or activated. The pin must be fixed to Low at power-on or power-down of the TB62269FTG.

ENABLE Input	Function
H	Output transistors are enabled (normal operation mode).
L	Output transistors are disabled (high impedance state).

CW/CCW Function

The CW/CCW pin controls the rotation direction of the motor. When set to 'Clockwise', the current of OUTA is output first, with a phase difference of 90°. When set to 'Counter clockwise', the current of OUTB is output first with a phase difference of 90°.

CW/CCW Input	Function	OUT (+)	OUT (-)
H	Clock-wise	H	L
L	Counter clock-wise	L	H

Step resolution Mode Select Function

D_MODE0	D_MODE1	D_MODE2	Function
L	L	L	STANDBY MODE OSCM, output transistors are disabled,full step setting
L	L	H	Full step
L	H	L	Half step(a)
L	H	H	Quarter step
H	L	L	Half step(b)
H	L	H	1/8 step
H	H	L	1/16 step
H	H	H	1/32 step

Change of D_MODE0, D_MODE1 and D_MODE2 recommends changing, after setting RESET to Low in the state of an initial(MO_OUT = Low).

RESET Function

RESET Input	Function
H	The electrical angle is reset.
L	Normal operation mode

Phase currents when RESET is applied are as follows:
In this case, the terminal MO_OUT becomes Low.

Step resolution	A aspect current	B aspect current	Electric Angle
Full step	100%	100%	45°
Half step	100%	100%	45°
Quarter step	71%	71%	45°
1/8 step	71%	71%	45°
1/16 step	71%	71%	45°
1/32 step	71%	71%	45°

Output function of reset signal

The L_OUT pin will show "Low" level when an error occation(TSD/ISD) is detected.

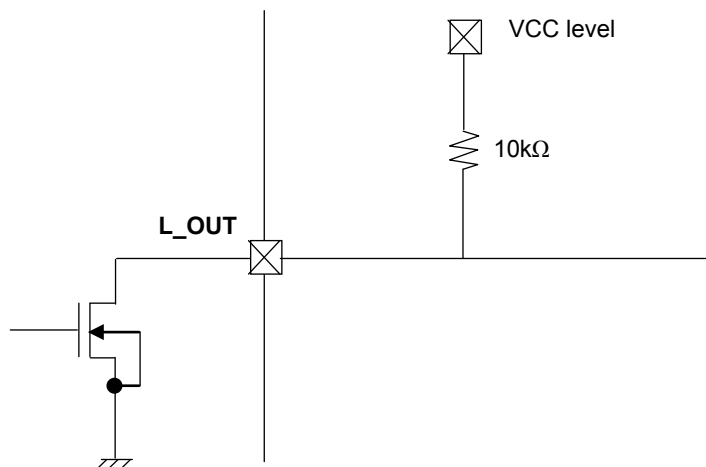

The LO is an open-drain output pin. LO pin needs to be pulled up to 3.3V/5.0V level for proper function. During regular operation, the LO pin level will stay High(VCC level). When error detection (TSD, ISD) is applied, the LO pin will show Low (GND) level.

Absolute Maximum Ratings (Ta = 25°C)

Characteristics	Symbol	Rating	Unit	Remarks
Motor power supply	VM	40	V	-
Motor output voltage	VOUT	40	V	-
Motor output current	IOUT	1.8	A	(Note 1)
Logic power supply	VCC	6.0	V	When externally applied.
Digital input voltage	VIN	6.0	V	-
MO,L_OUT output voltage	VMO,VL_OUT	6.0	V	-
MO,L_OUT Inflow current	IMO,IL_OUT	30.0	mA	-
Power dissipation	PD	1.3	W	(Note 2)
Operating temperature	Topr	-20 to 85	°C	-
Storage temperature	Tstr	-55 to 150	°C	-
Junction temperature	Tj(Max)	150	°C	-

Note 1: As a guide, the maximum output current should be kept below 1.4 A per phase. The maximum output current may be further limited in view of thermal considerations, depending on ambient temperature and board conditions.

Note 2: Stand-alone (Ta =25°C)

When Ta exceeds 25°C, it is necessary to do the deleting with 10.4mW/°C.

Ta: Ambient temperature

Topr: Ambient temperature while the TB62269FTG is active

Tj: Junction temperature while the TB62269FTG is active. The maximum junction temperature is limited by the thermal shutdown (TSD) circuitry. It is advisable to keep the maximum current below a certain level so that the maximum junction temperature, Tj (MAX), will not exceed 120°C.

Caution) Absolute maximum ratings

The absolute maximum ratings of a semiconductor device are a set of ratings that must not be exceeded, even for a moment. Do not exceed any of these ratings.

Exceeding the rating (s) may cause device breakdown, damage or deterioration, and may result in injury by explosion or combustion.

The value of even one parameter of the absolute maximum ratings should not be exceeded under any circumstances. The TB62269FTG does not have overvoltage detection circuit. Therefore, the device is damaged if a voltage exceeding its rated maximum is applied.

All voltage ratings, including supply voltages, must always be followed. The other notes and considerations described later should also be referred to.

Operation Ranges (Ta=0 to 85°C)

Characteristics	Symbol	Min	Typ.	Max	Unit	Remarks
Motor power supply	VM	10.0	24.0	38.0	V	
Motor output current	IOUT	-	1.4	1.8	A	1 phase, (Note 1)
Digital input voltage	VIN(H)	2.0	-	5.5	V	Logic input High Level
	VIN(L)	-0.4	-	1.0	V	Logic input Low Level
MO,L_OUT output pin voltage	VMO,VL_OUT	-	3.3	5.5	V	Pull-up Voltage
Clock input frequency	fCLK	-	-	100	kHz	
Chopper frequency	fchop	40	100	150	kHz	
Vref reference voltage	Vref	GND	-	3.6	V	
Sensing resistance contact button voltage	VRS	0.0	±1.0	±1.5	V	VM terminal standard, (Note 2)

Note 1: Maximum current for actual usage may be limited by the operating circumstances such as operating conditions (exciting mode, operating time, and so on), ambient temperature, and heat conditions (board condition and so on).

Note 2: Maximum voltage of VRS must not be exceeded the absolute maximum rating.

Electrical Characteristics 1 (Ta = 25°C, VM = 24V, unless otherwise specified)

Characteristics		Symbol	Test Condition	Min	Typ.	Max	Unit
Digital input voltage		VIH	Digital input pins (Note)	2.0	3.3	5.5	V
		VIL		0	-	0.8	
Input hysteresis voltage		VIN(HYS)	Digital input pins (Note)	100	200	300	mV
Digital input current	High	IIN(H)	VIN = 5 V at the digital input pins under test	35	50	75	μA
	Low	IIN(L)	VIN = 0 V at the digital input pins under test	-	-	1.0	μA
MO output voltage	High	VOH(MO)	IOH = -24 mA when the output is High	2.4	-	-	V
	Low	VOL(MO)	IOL = 24 mA when the output is Low	-	-	0.5	V
Supply current		IM1	Outputs open, In standby mode	-	2.5	3.5	mA
		IM2	Outputs open, ENABLE = Low	-	4.0	5.5	mA
		IM3	Outputs open (full step)	-	5	7	mA
Output leakage current	High-side	IOH	VRS = VM = 40 V, VOUT = 0 V	-	-	1	μA
	Low-side	IOL	VRS = VM = VOUT = 40 V	1	-	-	μA
Channel-to-channel differential		ΔIOUT1	Channel-to-channel error	-5	0	5	%
Output current error relative to the predetermined value		ΔIOUT2	IOUT = 1.0A	-5	0	5	%
RS pin current		IRS	VRS = VM = 24V, DMODE_0,1,2 = L ENABLE = L	0	-	27.0	μA
Drain-source ON-resistance of the output transistors (upper and lower sum)		RON(D-S)	IOUT = 2.0A, Tj = 25°C	-	0.8	1.2	Ω

Note: VIN (H) is defined as the VIN voltage that causes the outputs (OUTA,OUTB) to change when a pin under test is gradually raised from 0 V. VIN (L) is defined as the VIN voltage that causes the outputs (OUTA, OUTB) to change when the pin is then gradually lowered from 5V. The difference between VIN (H) and VIN (L) is defined as the VIN (HYS).

Electrical Characteristics 2 (Ta = 25°C, VM = 24V, unless otherwise specified)

Characteristics	Symbol	Test Condition	Min	Typ.	Max	Unit
Vref input current	Iref	Vref = 3.0 V	-	0	1.0	μA
Vref decay rate	Vref (GAIN)	Vref = 2.0 V	1/4.8	1/5.0	1/5.2	—
TSD threshold (Note 1))	TJTSD	-	140	150	170	°C
VM recovery voltage	VMR	Modes other than STANDBY MODE	7.0	8.0	9.0	V
Overcurrent trip threshold(Note 2)	ISD	-	2.0	3.0	4.0	A
Power-supply voltage for internal circuit operation	VCC	ICC=5.0mA	4.75	5.00	5.25	V

Note 1: Thermal shutdown (TSD) circuitry

When the junction temperature of the device reaches the threshold, the TSD circuitry is tripped, causing the internal reset circuitry to turn off the output transistors. The TSD circuitry is tripped at a temperature between 140°C (min) and 170°C (max). Once tripped, the TSD circuitry keeps the output transistors off until the TSD circuitry is released. The TSD status is released once the TB62269FTG is rebooted or all the D_MODE pins (D_MODE0,1,2) are switched to Low (set to STANDBY status). The TSD circuitry does not necessarily guarantee the complete safety of the device; therefore do not use the TSD circuitry actively.

Note 2: Overcurrent shutdown (ISD) circuitry

When the output current reaches the threshold, the ISD circuitry is tripped, causing the internal reset circuitry to turn off the output transistors. To prevent the ISD circuitry from being tripped owing to switching noise, it has a masking time of four CR oscillator cycles. Once tripped, it takes a maximum of four cycles to exit ISD mode and resume normal operation. The ISD circuitry remains active until all the D_MODE (DMODE_0,1,2) pins are switched to Low or the TB62269FTG is rebooted. The TB62269FTG remains in Standby mode while in ISD mode.

Note 3: When the power supply voltage (VCC) for operating internal circuit is divided by the external resistor and used as Vref input voltage, the accuracy of the output current setting value becomes ±8% together with the VCC output voltage accuracy and the Vref decay ratio accuracy.

Note 4: Even when the logic input signal is input under the condition that the VM voltage is not supplied, the electromotive force and the leakage current by the signal input are not generated. However, before VM is rebooted, logic input signal should be controlled not to let the motor operating by rebooting VM.

Back-EMF

While a motor is rotating, there is a timing at which power is fed back to the power supply. At that timing, the motor current is fed back to the power supply owing to the effect of the motor back-EMF.

If the power supply does not have enough sink capability, the power supply and output pins of the device might rise above the rated voltages. The magnitude of the motor back-EMF varies with usage conditions and motor characteristics. It must be fully verified that there is no risk that the TB62269FTG or other components will be damaged or fail owing to the motor back-EMF.

Cautions on Overcurrent Shutdown (ISD) and Thermal Shutdown (TSD)

The ISD and TSD circuits are only intended to provide temporary protection against irregular conditions such as an output short circuit; they do not necessarily guarantee complete IC safety.

If the device is used beyond the specified operating ranges, these circuits may not operate properly; then the device may be damaged owing to an output short circuit.

The ISD circuit is only intended to provide temporary protection against an output short circuit. If such a condition persists for a long time, the device may be damaged owing to overstress. Overcurrent conditions must be removed immediately by external hardware.

IC Mounting

Do not insert devices in the wrong orientation or incorrectly. Otherwise, it may cause device breakdown, damage and/or deterioration.

AC Electrical Characteristics (Ta = 25°C, VM = 24V, 6.8 mH/5.7Ω)

Characteristics		Symbol	Test Condition	Min	Typ.	Max	Unit
Logic input frequency		fCLK	fOSC=1600kHz	1.0	-	100	kHz
Width of minimum clock pulse	High	TCLK(H)	The input High period which carries out a High output	300	-	-	ns
	Low	TCLK(L)	The input Low period which carries out a Low output	250	-	-	
Output transistor Switching characteristic		tr	-	150	200	250	ns
		tf	-	100	150	200	ns
		tpLH(CLK)	CLK Signal to OUT	-	1000	-	ns
		tpHL(CLK)	CLK Signal to OUT	-	1500	-	ns
Blanking time for current spike prevention		tBLANK	Iout = 1.0A	450	700	950	ns
OSC_M oscillation frequency		fosc	Cosc = 270 pF, Rosc = 3.6 kΩ	1200	1600	2000	kHz
Chopper frequency range		fchop(RANGE)	Output operation (Iout = 1.0A)	30	100	150	kHz
Chopper setting frequency		fchop	Output operation (Iout = 1.0A) fOSC = 1600kHz	-	100	-	kHz
ISD masking time		tISD(Mask)	After ISD threshold is exceeded owing to an output short circuit to power or ground Mask time is counted by CLK of OSCM.	-	4	-	-
ISD on-time		tISD		-	-	8	

Timing Charts of Output Transistors Switching

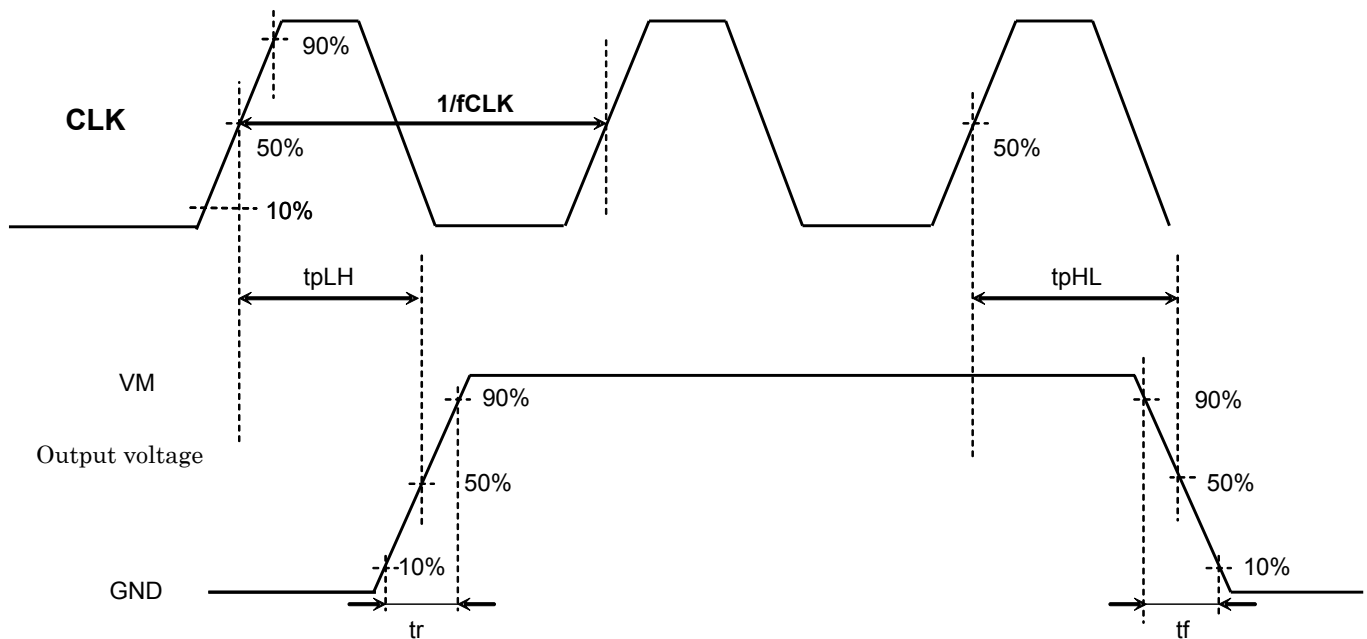

Timing charts may be simplified for explanatory purposes.

Mixed Decay Mode /Detecting zero point

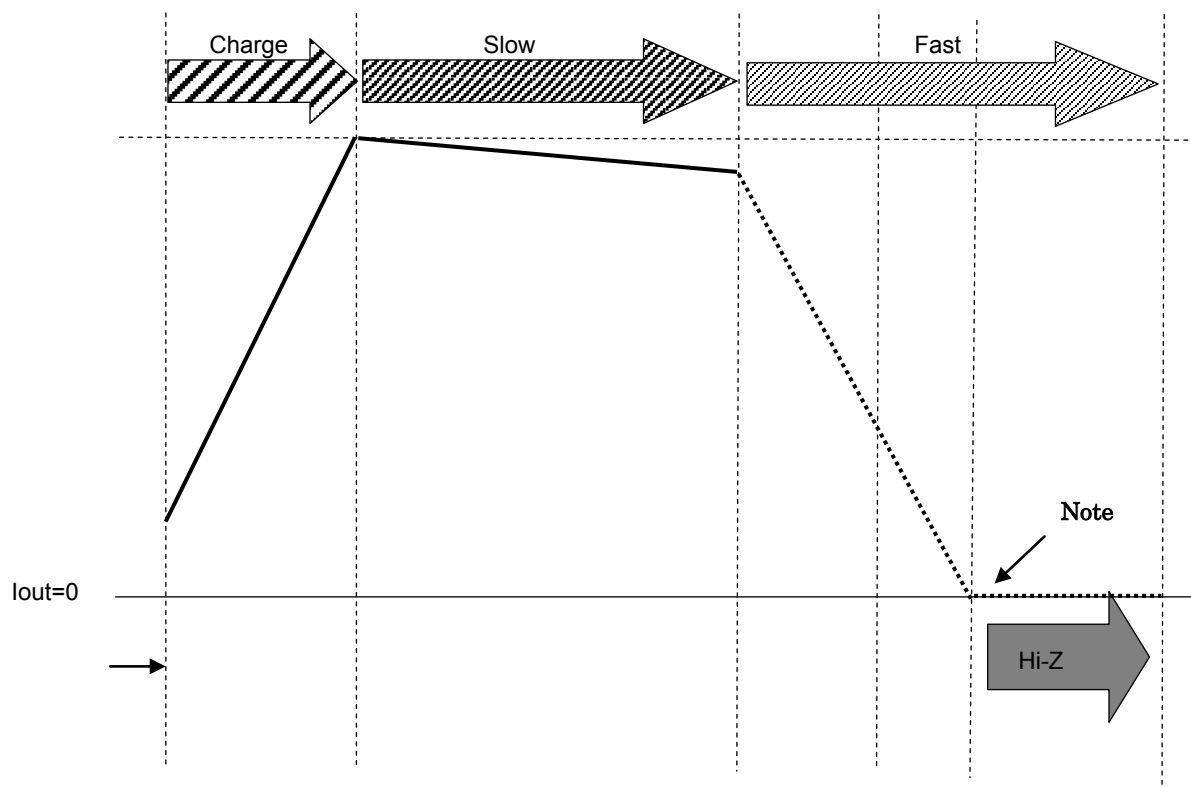
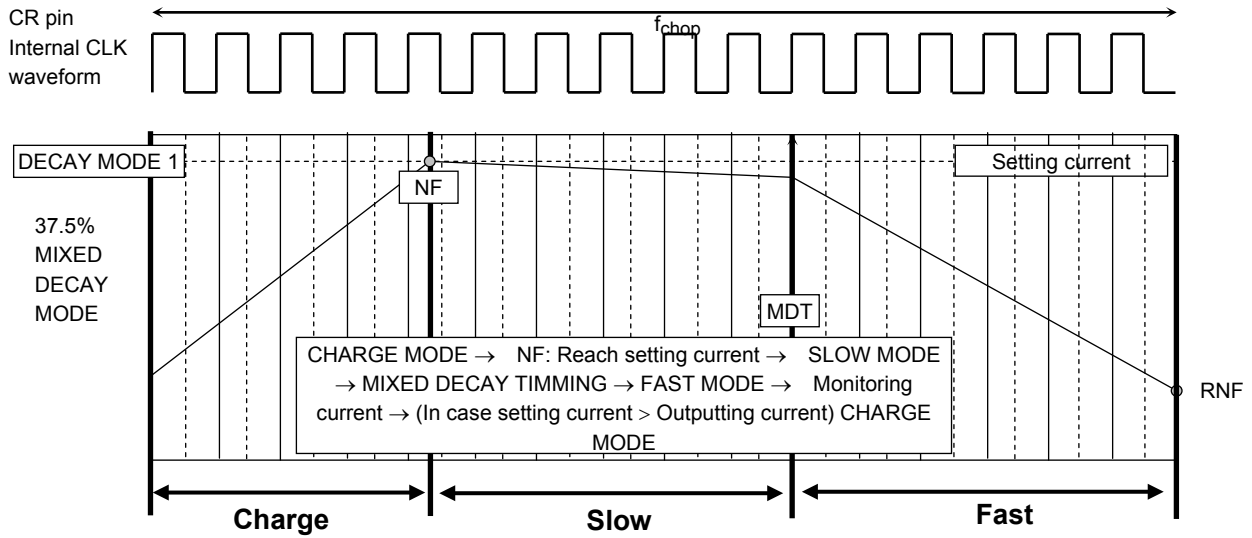

Note: When the motor current reaches the 0A level, the output transistor will turn to "Hi-Z" status.

Output Transistor Operating Modes

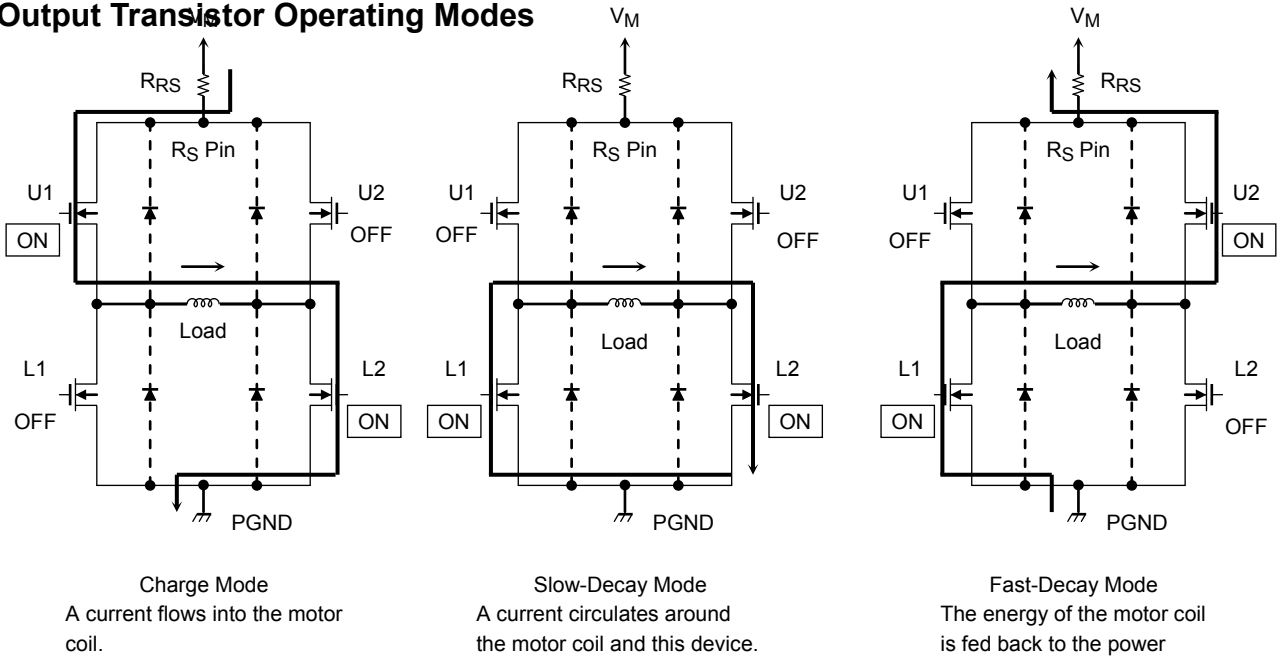

Output transistor function

CLK	U1	U2	L1	L2
Charge	ON	OFF	OFF	ON
Slow-decay Mode	OFF	OFF	ON	ON
Fast-decay Mode	OFF	ON	ON	OFF

Note: This table shows an example of when the current flows as indicated by the arrows in the figures shown above. If the current flows in the opposite direction, refer to the following table.

CLK	U1	U2	L1	L2
Charge	OFF	ON	ON	OFF
Slow-decay Mode	OFF	OFF	ON	ON
Fast-decay Mode	ON	OFF	OFF	ON

The TB62269FTG switches among Charge, Slow-Decay and Fast-Decay modes automatically for constant-current control.

The equivalent circuit diagrams may be simplified or some parts of them may be omitted for explanatory purposes.

Calculation of the Setting Output Current

For PWM constant-current control, the TB62269FTG uses a clock generated by the CR oscillator. The peak output current can be set via the current-sensing resistor (RRS) and the reference voltage (Vref), as follows:

$$I_{out}(\text{Max}) = V_{ref}(\text{gain}) \times \frac{V_{ref}(\text{V})}{R_{RS}(\Omega)}$$

Vref(gain): Vref decay ratio is 1 / 5.0 (typ.).

Ex.): In case of 100% setting,

When Vref = 3.0 V, Torque = 100%, and RS = 0.51Ω,

constant current output of the motor (peak current) is calculated as follows;

$$I_{out} = 3.0\text{V} / 5.0 / 0.51\Omega = 1.18 \text{ A.}$$

Calculation of the OSCM oscillation frequency (chopper reference frequency)

OSCM oscillation frequency (fOSCM) and chopper frequency (fchop) are computable in the following expressions.

$$f_{OSCM} = 1 / [0.56 \times \{C_x(R1 + 500)\}] \quad \dots\dots\dots C, R1: \text{External constant for OSCM (C=270pF, R1=3.6k}\Omega\text{)}$$

$$f_{chop} = f_{OSCM} / 16$$

Because the loss of the gate in IC rises, generation of heat grows though wavy reproducibility goes up because the pulsating flow of the current decreases when the chopper frequency is raised.

There is a possibility of the current pulsating flow increasing though a decrease in generation of heat can be expected by lowering the chopper frequency.

The thing set within the range of the frequency from 50 to about 100 kHz based on the frequency generally of about 70 kHz is recommended.

IC Power Consumption

The power consumed by the TB62269FTG is approximately the sum of the following; 1) the power consumed by the output transistors, and 2) the power consumed by the digital logic portion.

1. Power consumption of output transistors using the RON (upper + lower) value of 1.0 Ω

The power of the output transistors is consumed by upper and lower H-bridge.

The power consumed by each H-bridge is given by:

$$P \text{ (out)} = I_{out} \text{ (A)} \times V_{DS} \text{ (V)} = I_{out} \text{ (A)}^2 \times R_{on} \text{ (}\Omega\text{)} \dots\dots\dots (1)$$

In full step mode (in which two phases have a phase difference of 90°), the average power consumption in the output transistors is calculated as follows:

$$\begin{aligned} R_{on} &= 1.0\Omega, I_{out} \text{ (peak: Max)} = 1.0 \text{ A, } V_M = 24 \text{ V} \\ P \text{ (out)} &= 2 \text{ (Tr)} \times 1.0 \text{ (A)}^2 \times 1.0(\Omega) \dots\dots\dots (2) \\ &= 2.0 \text{ (W)} \end{aligned}$$

2. Power consumption of logic portion and IM domain

The power consumption of logic portion and the IM domain is calculated separately for normal operation and standby modes.

- I (IM3) = 5 mA (typ.) : Normal operation mode/1axis
- I (IM2) = 3.5 mA (typ.) : Standby mode

The output domain is connected to VM (24V). It consists of the digital logic connected to VM (24 V) and the network affected by the switching of the output transistors.

The total power consumed by IM can be estimated as:

$$\begin{aligned} P \text{ (IM)} &= 24 \text{ (V)} \times 0.005 \text{ (A)} \dots\dots\dots (3) \\ &= 0.12 \text{ (W)} \end{aligned}$$

3. Power consumption

Hence, the total power consumption of the TB62269FTG is:

$$P = P \text{ (out)} + P \text{ (IM)} = 2.12 \text{ (W)}$$

The standby power consumption per axis is given by:

$$P \text{ (Standby)} = 24 \text{ (V)} \times 0.0035 \text{ (A)} = 0.084 \text{ (W)}$$

Board design should be fully verified, taking thermal dissipation into consideration.

Timing Charts of CLK, Output Current and MO Output

Timing charts may be simplified for explanatory purposes.

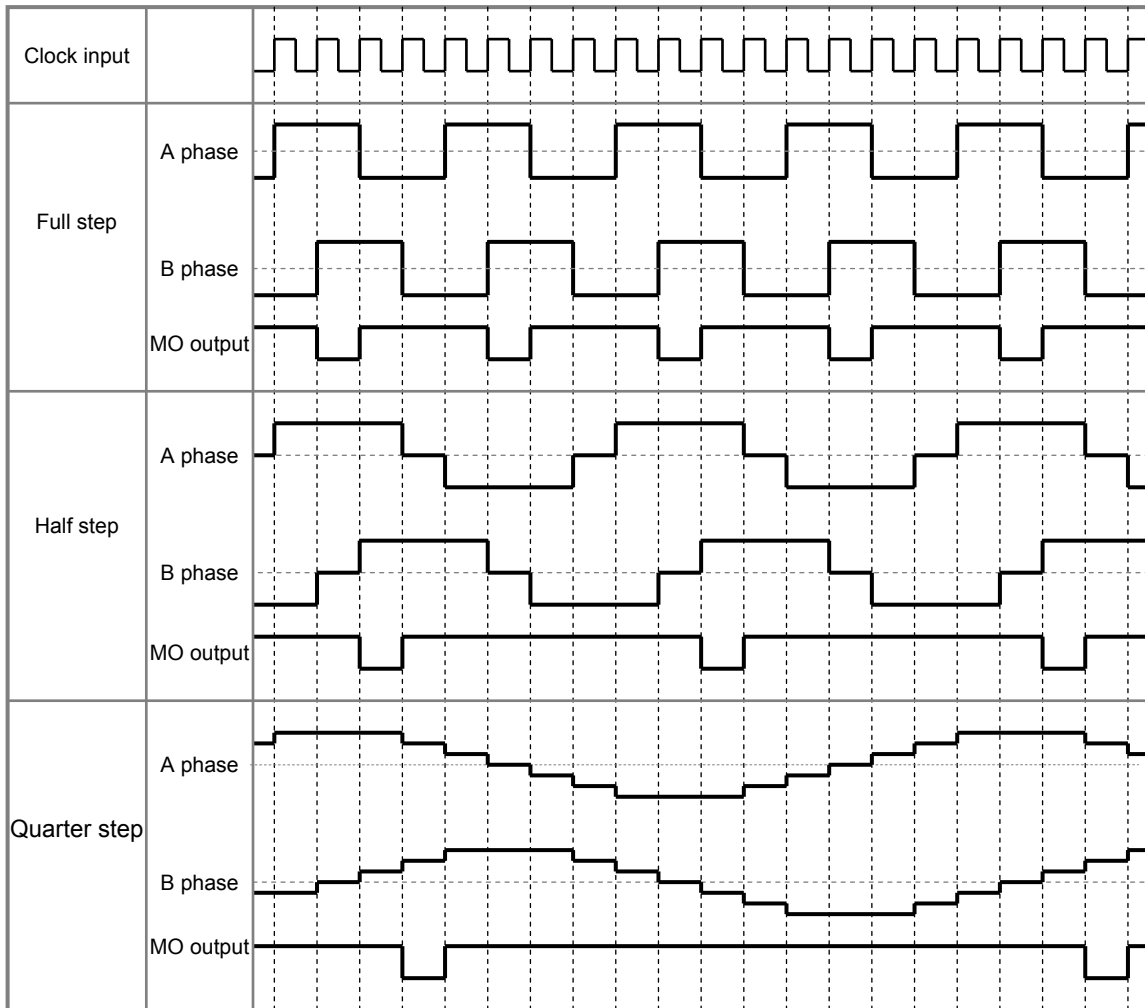

MO output shown in the timing chart is when the MO pin is pulled up.

Phase Sequences

Full step resolution

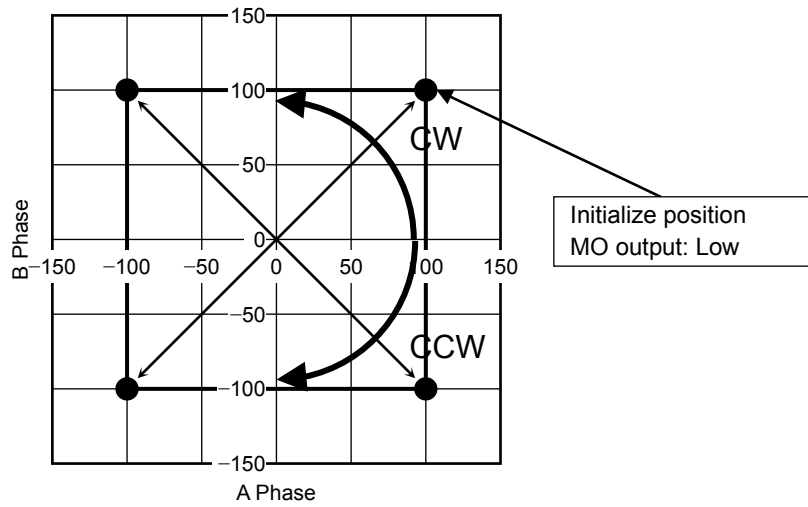

Half Step resolution

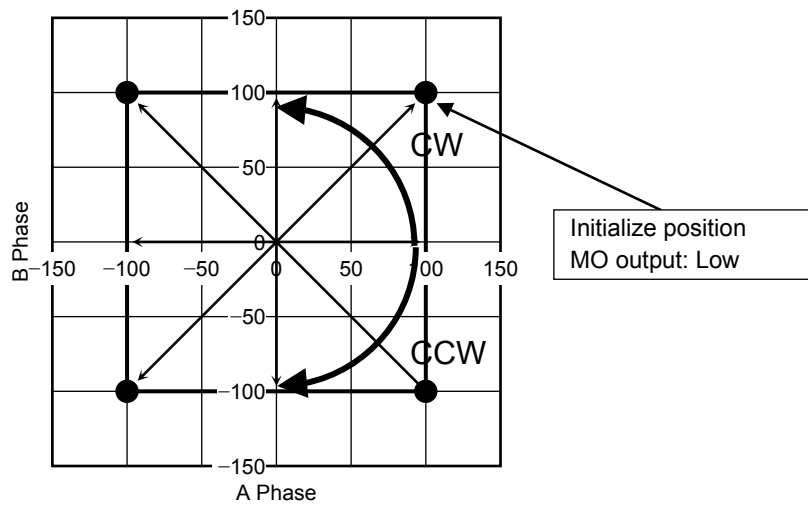

Quarter Step resolution

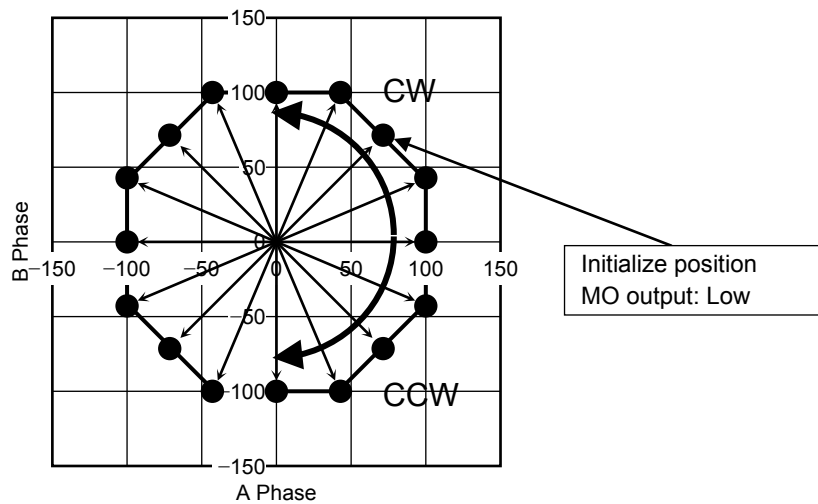

Half Step resolution (b)

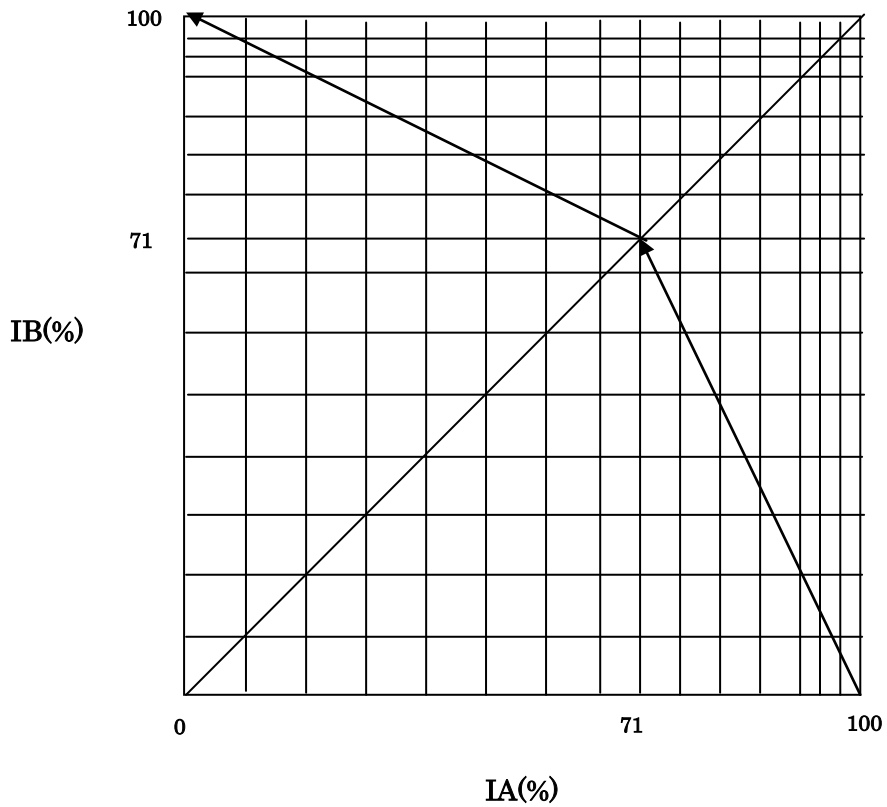
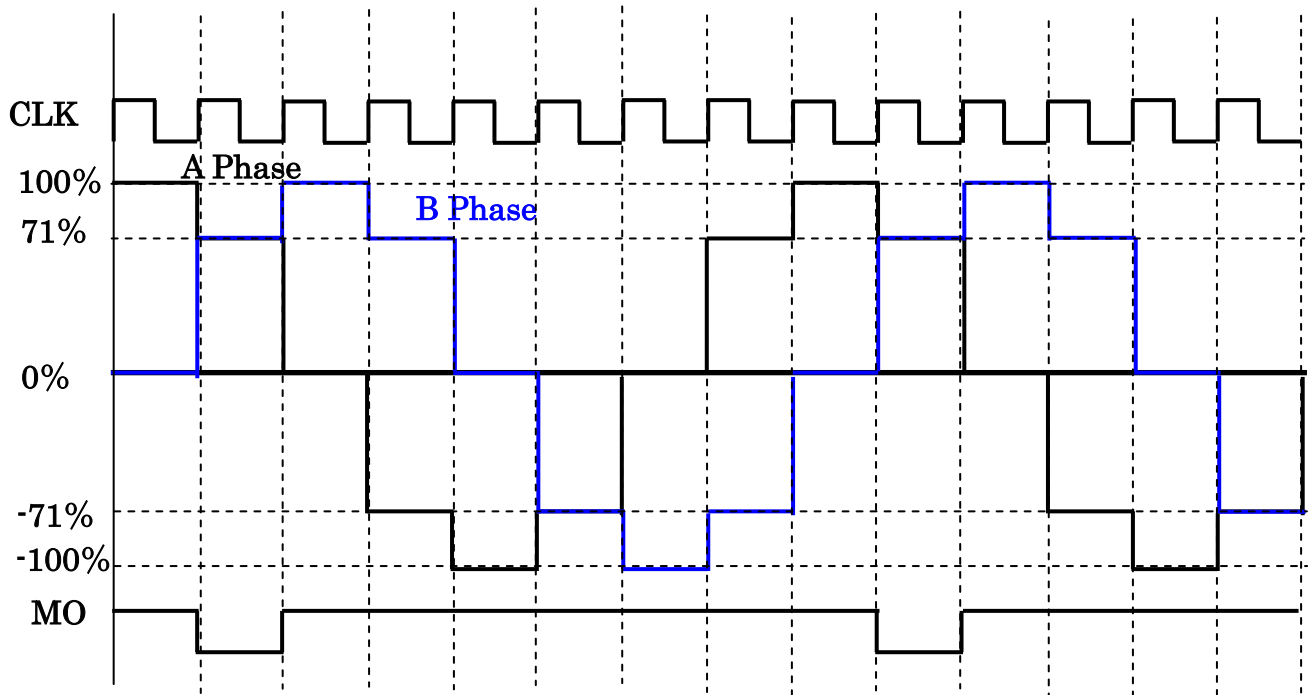

1/8 Step resolution

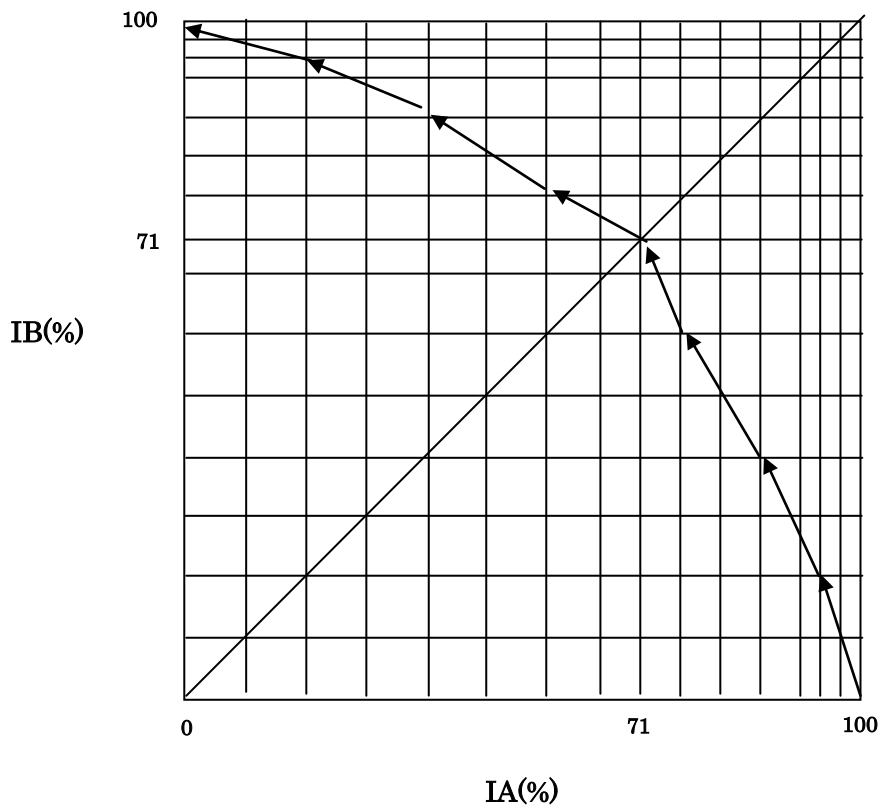
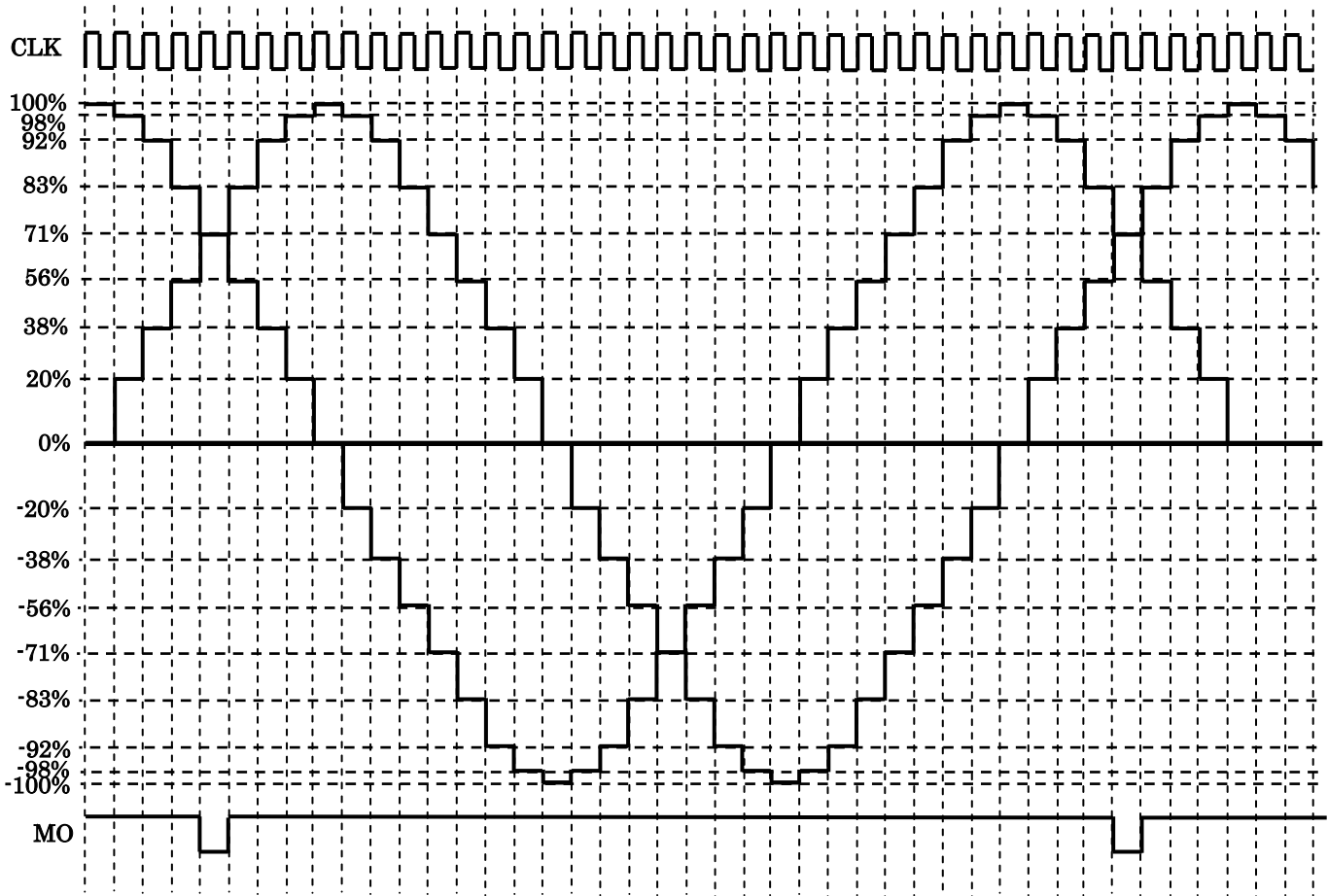

1/16 Step resolution

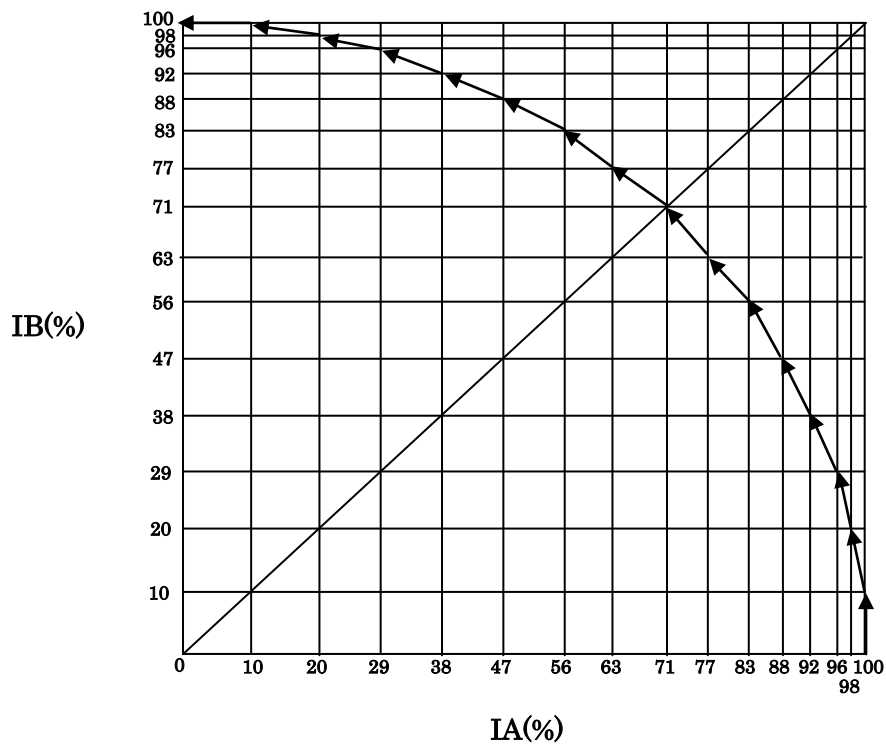
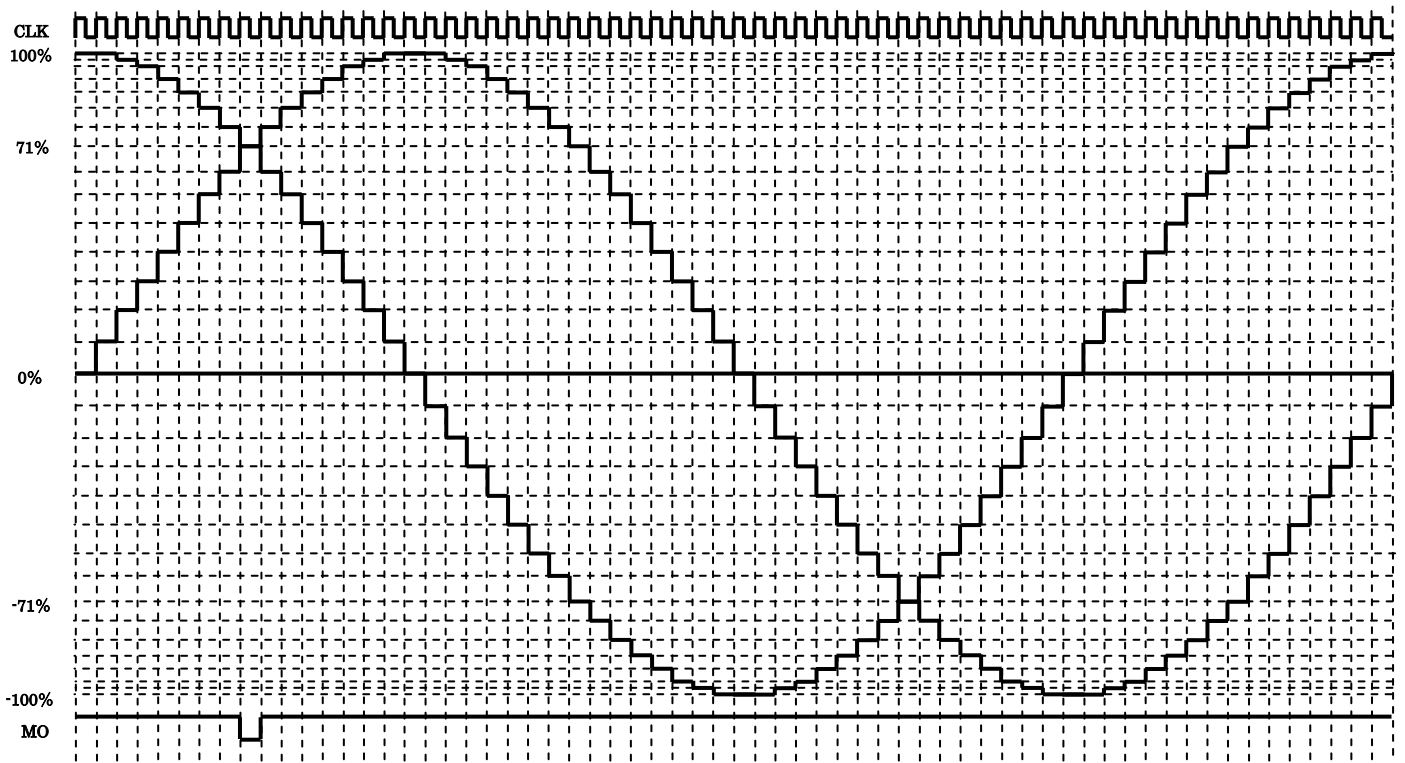

1/32 Step resolution

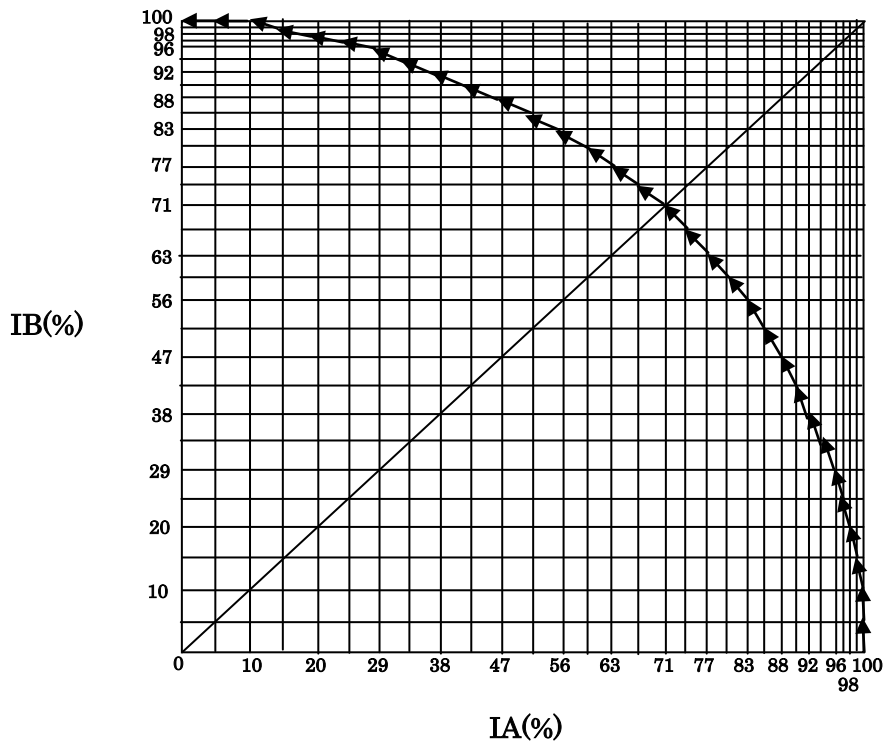
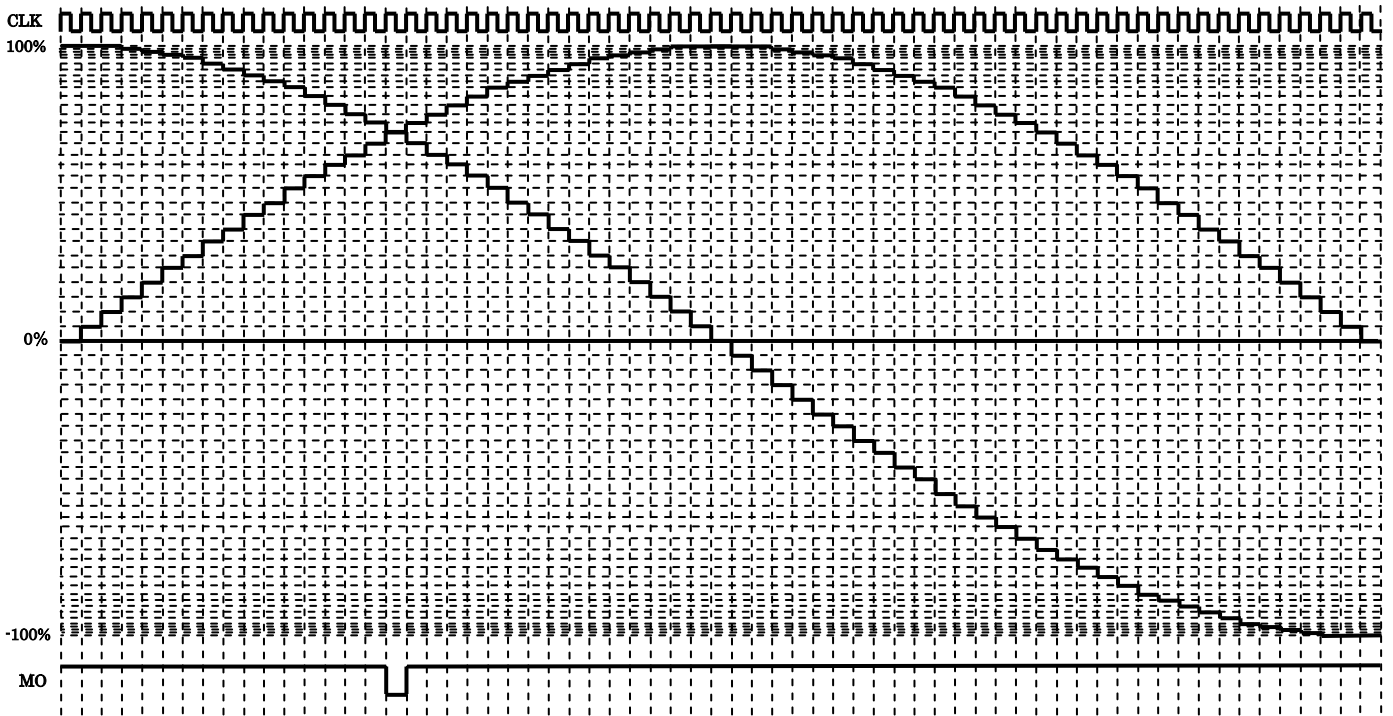

Example Application Circuits

The values shown in the following figure are typical values. For input conditions, see the Operating Ranges.

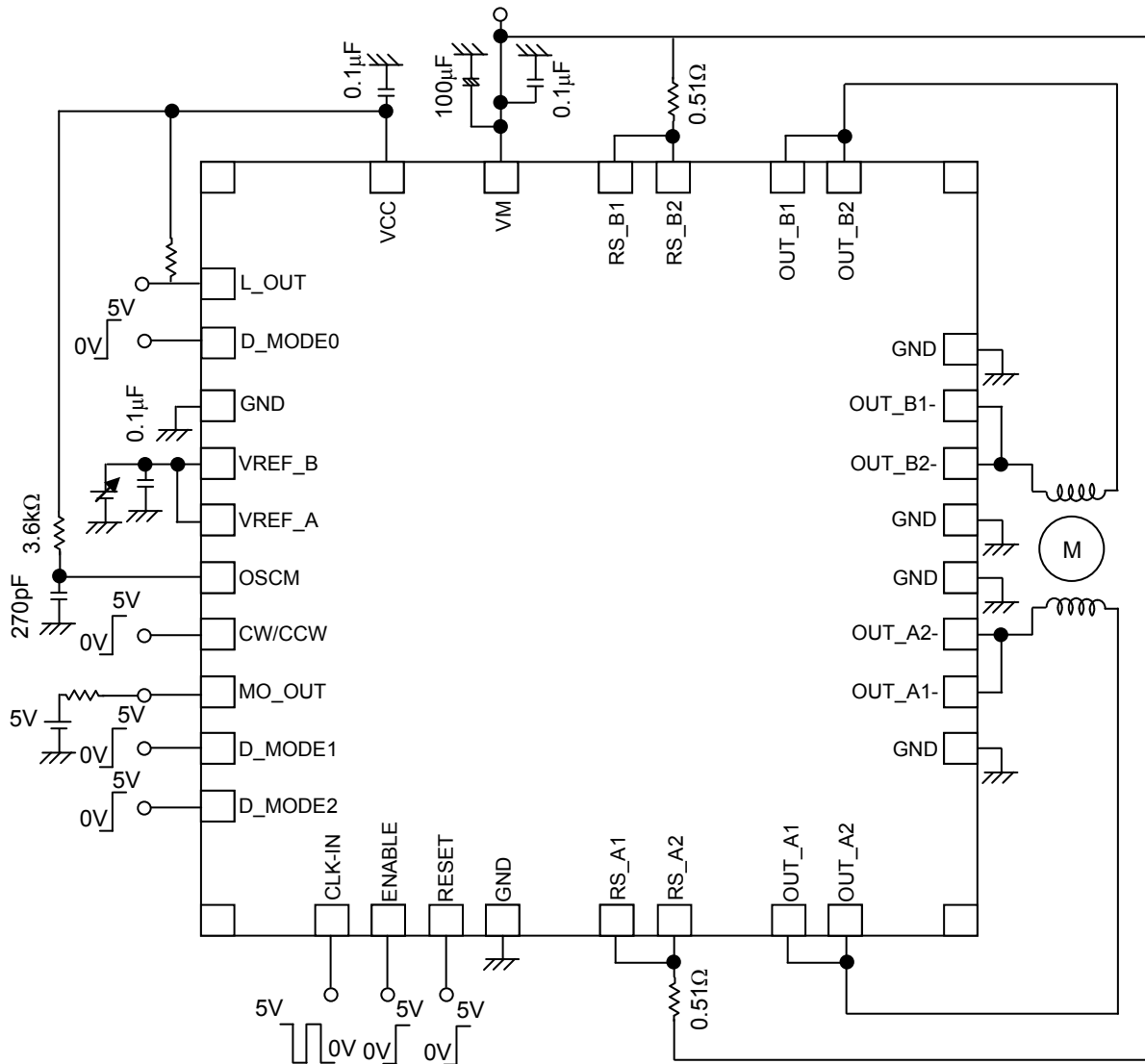

Note: I will recommend the addition of a capacitor if necessary. The GND wiring must become one point as much as possible-earth.

The example of an applied circuit is for reference, and enough evaluation should be done before the mass-production design.

Moreover, it is not the one to permit the use of the industrial property.

Notes on Contents

Block Diagrams

Some of the functional blocks, circuits, or constants in the block diagram may be omitted or simplified for explanatory purposes.

Equivalent Circuits

The equivalent circuit diagrams may be simplified or some parts of them may be omitted for explanatory purposes.

Timing Charts

Timing charts may be simplified for explanatory purposes.

Application Circuits

The application circuits shown in this document are provided for reference purposes only. Thorough evaluation is required, especially at the mass-production design stage.

Toshiba does not grant any license to any industrial property rights by providing these examples of application circuits.

Test Circuits

Components in the test circuits are used only to obtain and confirm the device characteristics. These components and circuits are not guaranteed to prevent malfunction or failure from occurring in the application equipment.

IC Usage Considerations

Notes on handling of ICs

- (1) The absolute maximum ratings of a semiconductor device are a set of ratings that must not be exceeded, even for a moment. Do not exceed any of these ratings. Exceeding the rating(s) may cause device breakdown, damage or deterioration, and may result in injury by explosion or combustion.
- (2) Use an appropriate power supply fuse to ensure that a large current does not continuously flow in the case of overcurrent and/or IC failure. The IC will fully break down when used under conditions that exceed its absolute maximum ratings, when the wiring is routed improperly or when an abnormal pulse noise occurs from the wiring or load, causing a large current to continuously flow and the breakdown can lead to smoke or ignition. To minimize the effects of the flow of a large current in the case of breakdown, appropriate settings, such as fuse capacity, fusing time and insertion circuit location, are required.
- (3) If your design includes an inductive load such as a motor coil, incorporate a protection circuit into the design to prevent device malfunction or breakdown caused by the current resulting from the inrush current at power ON or the negative current resulting from the back electromotive force at power OFF. IC breakdown may cause injury, smoke or ignition. Use a stable power supply with ICs with built-in protection functions. If the power supply is unstable, the protection function may not operate, causing IC breakdown. IC breakdown may cause injury, smoke or ignition.
- (4) Do not insert devices in the wrong orientation or incorrectly. Make sure that the positive and negative terminals of power supplies are connected properly. Otherwise, the current or power consumption may exceed the absolute maximum rating, and exceeding the rating(s) may cause device breakdown, damage or deterioration, and may result in injury by explosion or combustion. In addition, do not use any device inserted in the wrong orientation or incorrectly to which current is applied even just once.
- (5) Carefully select external components (such as inputs and negative feedback capacitors) and load components (such as speakers), for example, power amp and regulator. If there is a large amount of leakage current such as from input or negative feedback condenser, the IC output DC voltage will increase. If this output voltage is connected to a speaker with low input withstand voltage, overcurrent or IC failure may cause smoke or ignition. (The overcurrent may cause smoke or ignition from the IC itself.) In particular, please pay attention when using a Bridge Tied Load (BTL) connection-type IC that inputs output DC voltage to a speaker directly.

Points to remember on handling of ICs**Overcurrent detection Circuit**

Overcurrent detection circuits (referred to as current limiter circuits) do not necessarily protect ICs under all circumstances. If the overcurrent detection circuits operate against the overcurrent, clear the overcurrent status immediately.

Depending on the method of use and usage conditions, exceeding absolute maximum ratings may cause the overcurrent detection circuit to operate improperly or IC breakdown may occur before operation. In addition, depending on the method of use and usage conditions, if overcurrent continues to flow for a long time after operation, the IC may generate heat resulting in breakdown.

Thermal Shutdown Circuit

Thermal shutdown circuits do not necessarily protect ICs under all circumstances. If the thermal shutdown circuits operate against the over-temperature, clear the heat generation status immediately.

Depending on the method of use and usage conditions, exceeding absolute maximum ratings may cause the thermal shutdown circuit to operate improperly or IC breakdown to occur before operation.

Heat Radiation Design

When using an IC with large current flow such as power amp, regulator or driver, design the device so that heat is appropriately radiated, in order not to exceed the specified junction temperature (T_J) at any time or under any condition. These ICs generate heat even during normal use. An inadequate IC heat radiation design can lead to decrease in IC life, deterioration of IC characteristics or IC breakdown. In addition, when designing the device, take into consideration the effect of IC heat radiation with peripheral components.

Back-EMF

When a motor rotates in the reverse direction, stops or slows abruptly, current flows back to the motor's power supply owing to the effect of back-EMF. If the current sink capability of the power supply is small, the device's motor power supply and output pins might be exposed to conditions beyond the absolute maximum ratings. To avoid this problem, take the effect of back-EMF into consideration in system design.

RESTRICTIONS ON PRODUCT USE

- Toshiba Corporation, and its subsidiaries and affiliates (collectively "TOSHIBA"), reserve the right to make changes to the information in this document, and related hardware, software and systems (collectively "Product") without notice.
- This document and any information herein may not be reproduced without prior written permission from TOSHIBA. Even with TOSHIBA's written permission, reproduction is permissible only if reproduction is without alteration/omission.
- Though TOSHIBA works continually to improve Product's quality and reliability, Product can malfunction or fail. Customers are responsible for complying with safety standards and for providing adequate designs and safeguards for their hardware, software and systems which minimize risk and avoid situations in which a malfunction or failure of Product could cause loss of human life, bodily injury or damage to property, including data loss or corruption. Before customers use the Product, create designs including the Product, or incorporate the Product into their own applications, customers must also refer to and comply with (a) the latest versions of all relevant TOSHIBA information, including without limitation, this document, the specifications, the data sheets and application notes for Product and the precautions and conditions set forth in the "TOSHIBA Semiconductor Reliability Handbook" and (b) the instructions for the application with which the Product will be used with or for. Customers are solely responsible for all aspects of their own product design or applications, including but not limited to (a) determining the appropriateness of the use of this Product in such design or applications; (b) evaluating and determining the applicability of any information contained in this document, or in charts, diagrams, programs, algorithms, sample application circuits, or any other referenced documents; and (c) validating all operating parameters for such designs and applications. **TOSHIBA ASSUMES NO LIABILITY FOR CUSTOMERS' PRODUCT DESIGN OR APPLICATIONS.**
- **PRODUCT IS NEITHER INTENDED NOR WARRANTED FOR USE IN EQUIPMENTS OR SYSTEMS THAT REQUIRE EXTRAORDINARILY HIGH LEVELS OF QUALITY AND/OR RELIABILITY, AND/OR A MALFUNCTION OR FAILURE OF WHICH MAY CAUSE LOSS OF HUMAN LIFE, BODILY INJURY, SERIOUS PROPERTY DAMAGE AND/OR SERIOUS PUBLIC IMPACT ("UNINTENDED USE").** Except for specific applications as expressly stated in this document, Unintended Use includes, without limitation, equipment used in nuclear facilities, equipment used in the aerospace industry, Class 3 medical devices, equipment used for automobiles, and military vehicles and munitions. **IF YOU USE PRODUCT FOR UNINTENDED USE, TOSHIBA ASSUMES NO LIABILITY FOR PRODUCT.** For details, please contact your TOSHIBA sales representative or contact us via our website.
- Do not disassemble, analyze, reverse-engineer, alter, modify, translate or copy Product, whether in whole or in part.
- Product shall not be used for or incorporated into any products or systems whose manufacture, use, or sale is prohibited under any applicable laws or regulations.
- The information contained herein is presented only as guidance for Product use. No responsibility is assumed by TOSHIBA for any infringement of patents or any other intellectual property rights of third parties that may result from the use of Product. No license to any intellectual property right is granted by this document, whether express or implied, by estoppel or otherwise.
- **ABSENT A WRITTEN SIGNED AGREEMENT, EXCEPT AS PROVIDED IN THE RELEVANT TERMS AND CONDITIONS OF SALE FOR PRODUCT, AND TO THE MAXIMUM EXTENT ALLOWABLE BY LAW, TOSHIBA (1) ASSUMES NO LIABILITY WHATSOEVER, INCLUDING WITHOUT LIMITATION, INDIRECT, CONSEQUENTIAL, SPECIAL, OR INCIDENTAL DAMAGES OR LOSS, INCLUDING WITHOUT LIMITATION, LOSS OF PROFITS, LOSS OF OPPORTUNITIES, BUSINESS INTERRUPTION AND LOSS OF DATA, AND (2) DISCLAIMS ANY AND ALL EXPRESS OR IMPLIED WARRANTIES AND CONDITIONS RELATED TO SALE, USE OF PRODUCT, OR INFORMATION, INCLUDING WARRANTIES OR CONDITIONS OF MERCHANTABILITY, FITNESS FOR A PARTICULAR PURPOSE, ACCURACY OF INFORMATION, OR NONINFRINGEMENT.**
- Do not use or otherwise make available Product or related software or technology for any military purposes, including without limitation, for the design, development, use, stockpiling or manufacturing of nuclear, chemical, or biological weapons or missile technology products (mass destruction weapons). Product and related software and technology may be controlled under the applicable export laws and regulations including, without limitation, the Japanese Foreign Exchange and Foreign Trade Law and the U.S. Export Administration Regulations. Export and re-export of Product or related software or technology are strictly prohibited except in compliance with all applicable export laws and regulations.
- Please contact your TOSHIBA sales representative for details as to environmental matters such as the RoHS compatibility of Product. Please use Product in compliance with all applicable laws and regulations that regulate the inclusion or use of controlled substances, including without limitation, the EU RoHS Directive. **TOSHIBA ASSUMES NO LIABILITY FOR DAMAGES OR LOSSES OCCURRING AS A RESULT OF NONCOMPLIANCE WITH APPLICABLE LAWS AND REGULATIONS.**