

TB6585AFTG

3-Phase Sine-Wave PWM Driver for BLDC Motors

Features

- Sine-wave PWM drive
- Triangular-wave generator
- Hall amplifier
- Lead angle control
- Current limit control input ($V_{RS} = 0.5 \text{ V (typ.)}$)
- Rotation pulse output (3 pulse/electrical degree 360°)
- Operating supply voltage range: $V_M = 4.5 \text{ to } 42 \text{ V}$
- Reference supply output: $V_{refout} = 4.4 \text{ V (typ.)}$, 20 mA (max)
- Output current: $I_{OUT} = 1.8 \text{ A (max)}$, 1.2 A (typ.)
- Output On-resistance R_{on} (P-channel and N-channel sum) = 0.7Ω (typ.)

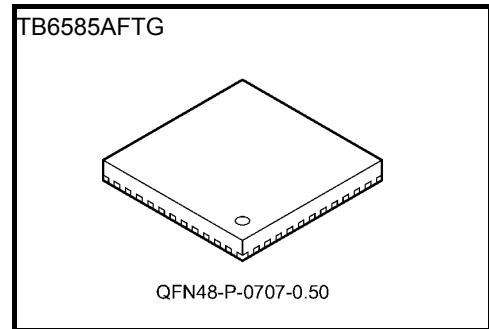

Weight: QFN48-P-0707-0.50: 0.15 g (typ.)

Pin Assignment

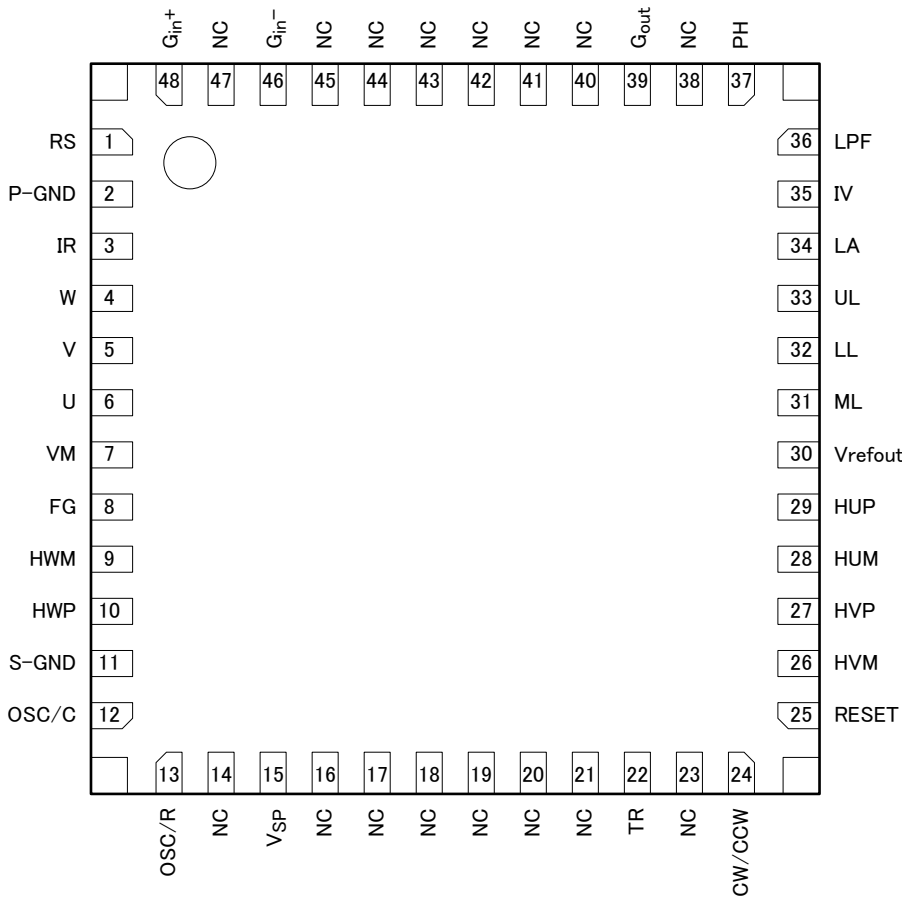

Pin Description

Pin No	Pin name	Description
7	VM	Motor power supply pin (VM = 4.5 to 42 V)
8	FG	Rotation speed output pin (3 pulses per electrical degree)
9	HWM	W-phase Hall-signal input (-)
10	HWP	W-phase Hall signal input (+)
11	S-GND	Signal ground
12	OSC/C	Connection pin for a capacitor to control PWM oscillation
13	OSC/R	Connection pin for a resistor to control PWM oscillation
15	V _{SP}	Speed control input
22	TR	Time setting pin for the anti-lock system
24	CW/CCW	Rotation direction select input
25	RESET	Reset pin for disabling the outputs
26	HVM	V-phase Hall-signal input (-)
27	HVP	V-phase Hall-signal input (+)
28	HUM	U-phase Hall-signal input (-)
29	HUP	U-phase Hall-signal input (+)
30	V _{refout}	Reference voltage output (V _{refout} = 4.4 V (typ.), I _{refout} = 20 mA (max)), connection pin for an oscillation prevention capacitor
31	ML	Restart operation select input for the anti-lock system
32	LL	Lower limit control for lead angle
33	UL	Upper limit control for lead angle
34	LA	Lead angle select input (This input is used to determine the lead-angle under the automatic lead-angle control.)
35	IV	Voltage output converted from the output current
36	LPF	Connection pin for a filter capacitor
37	PH	Connection pin for a peak-hold capacitor
39	G _{out}	Amplified shunt voltage
46	G _{in-}	Connection pin for an amplifier resistor
48	G _{in+}	Shunt voltage input
1	RS	Overcurrent protection input (Disables outputs when RS ≥ 0.5 V)
2	P-GND	Power ground
3	IR	Connection pin for an output shunt resistor
4	W	W-phase output
5	V	V-phase output
6	U	U-phase output
14, 16, 17, 18, 19, 20, 21, 23, 38, 40, 41, 42, 43, 44, 45, 47	N.C	No-connect

I/O Equivalent Circuits

Some parts are omitted from the equivalent circuit diagrams or simplified for the sake of simplicity.

Pin Description	Symbol	I/O Signal	Internal Circuit Diagram
Position signal inputs	HUP HUM HVP HVM HWP HWM	Analog Hysteresis: ± 8 mV (typ.)	
Speed control input	V _{SP}	Analog Input range: 0 to V _{refout}	
Rotation direction select input L: Clockwise (CW) H: Counterclockwise (CCW)	CW/CCW	Digital L: 0.8 V (max) H: 2.0 V (min) Hysteresis: 200 mV (typ.)	
Reset input L: Drives a motor H: Reset	RESET	Digital L: 0.8 V (max) H: 2.0 V (min) Hysteresis: 200 mV (typ.) At reset: Outputs are disabled; internal counter keeps running.	
Lead angle control input 0 V: 0° 3.0 V: 29° (5-bit AD converter)	LA	When fixing the lead angle externally, connect LL to GND and UL to V _{refout} . Also, apply a control voltage to the LA pin. Input range: 0 to 4.4 V (V _{refout}) When an input voltage of 3.0 V or higher is applied, the lead angle is clipped to a maximum of 29°. The LA pin should be left open when using the automatic-lead-angle control. At this time, the LA pin can be used for determining the lead angle.	

Pin Description	Symbol	I/O Signal	Internal Circuit Diagram
Gain control inputs (Lead-angle controller)	G_{in-} G_{in+} G_{out}	Non-inverting amplifier 25dB (max) G_{out} output voltage Low: GND High: $V_{refout} - 0.4\text{ V}$	
Peak-hold (Lead-angle controller)	PH	This pin is connected to a peak-hold capacitor and a discharge resistor. 100 k Ω /0.1 μ F	
Low-pass filter (Lead-angle controller)	LPF	This pin is connected to an RC filter (low-pass filter) capacitor. This pin has an internal resistor of 100 k Ω (typ.). 0.1 μ F	
Lead-angle lower-limit control	LL	The lead angle is clipped to the lower limit. $LL = 0\text{ V}$ to 4.4 V (V_{refout}) When $LL > UL$, LA is fixed to the value determined by LL.	
Lead-angle upper-limit control	UL	The lead angle is clipped to the upper limit. $UL = 0\text{ V}$ to 4.4 V (V_{refout}) When $LL > UL$, LA is fixed to the value determined by LL.	

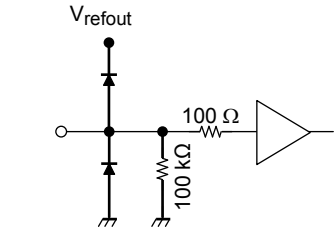
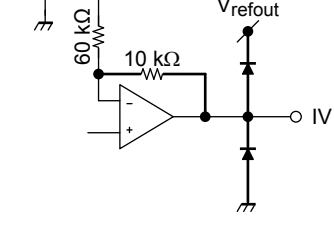
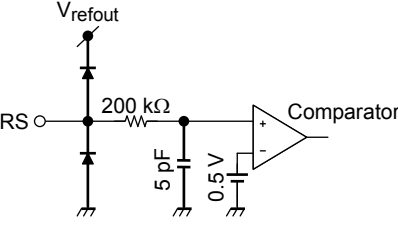
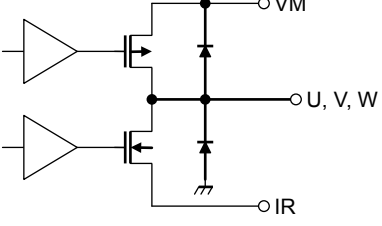
Pin Description	Symbol	I/O Signal	Internal Circuit Diagram
Restart operation select input for the anti-lock system L: Restart with power cycling H: Automatic restart	ML	Digital L: 0.8 V (max) H: 2.0 V (min)	
Voltage output converted from output current	IV	Analog IV = 0.5 V to 3.5 V (± 2 mA (max)) Gain = 1.2 (typ.)	
Current-limiting input	RS	Analog Digital filter: 1 μ s (typ.) The gate block protection is activated when RS reaches 0.5 V. (Disabled every carrier cycle)	
U-phase, V-phase and W-phase outputs	U V W	Motor drive output I _{OUT} = 1.2 A (typ.) 1.8 A (max)	

Absolute Maximum Ratings (T_a = 25°C)

Characteristics	Symbol	Rating	Unit
Power supply voltage	V _M	45	V
Input voltage	V _{IN}	4.7	V
Output current	I _{OUT}	1.8 (Note 1)	A
Power dissipation	P _D	3.9 (Note 2)	W
Operating temperature	T _{opr}	-30 to 85	°C
Storage temperature	T _{stg}	-55 to 150	

Note 1: Output current may be limited by the ambient temperature or a heatsink.
The maximum junction temperature should not exceed T_{jmax} = 150°C.

Note 2: Measured on a board. (100 mm × 100 mm × t1.5 mm, Double-layers)

Package Power Dissipation

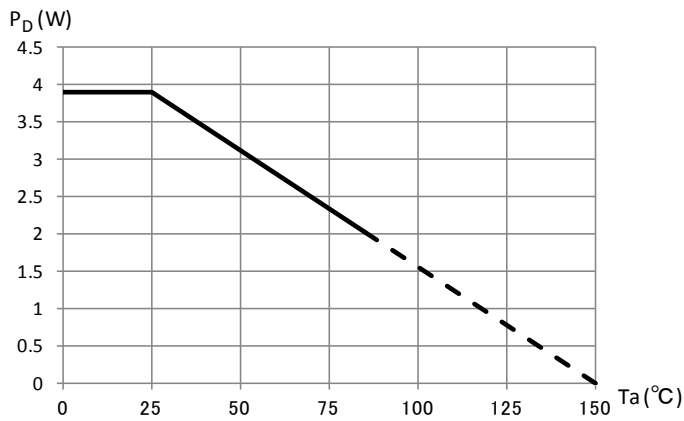

Measured on a board (100 mm × 100 mm × t1.5 mm, Double-layers) R_{th(j-a)} = 32°C/W

Operating Ranges (T_a = 25°C)

Characteristics	Symbol	Min	Typ.	Max	Unit
Power supply voltage	V _M	4.5	24	42	V
Oscillation frequency bandwidth	F _{OSC}	4	5	6	MHz

Electrical Characteristics (T_a = 25°C, V_M = 24 V)

Characteristics		Symbol	Test Conditions	Min	Typ.	Max	Unit	
Power supply current		I _M	Pre-drive current + control current, I _{refout} = 0 mA	—	7	14	mA	
Input current		I _{in} (1)	V _{in} = 4.4 V LA	—	22	40	μA	
		I _{in} (2)	V _{in} = 4.4 V VSP	—	30	60		
		I _{in} (3)	V _{in} = 4.4 V RESET, ML, CW/CCW	—	44	80		
Hall amplifier	In-phase input voltage range	V _{CMRH}		1.5	—	3.5	V	
	Input voltage swing	V _H		50	—	—	mVpp	
	Input hysteresis	V _{hysH}	(Note)	±4	±8	±12	mV	
	Input current	I _{inH}	V _{CMRH} = 2.5 V, single phase	-1	—	1	μA	
Input voltage		V _{in}	High	CW/CCW, RESET, ML	2.0	—	V _{refout} +0.2	V
			Low		0	—	0.8	
		V _{in} Hys	CW/CCW, RESET, ML	—	0.2	—		
		V _{SP} (4.4)	Modulated wave: max	V _{refout} -0.2	—	V _{refout} +0.2		
		V _{SP} (0.5)	Commutation OFF → Start motor operation	0.3	0.5	0.7		
Output ON-resistance		R _{ON} (H+L)	I _{OUT} = 1.2 A U, V, W	—	0.7	1.0	Ω	
V _{refout} output voltage		V _{refout}	I _{refout} = 20 mA V _{refout}	4.0	4.4	4.8	V	
FG output voltage		V _{FG} (H)	I _{OUT} = 1 mA FG	V _{refout} -1.0	V _{refout} -0.2	—	V	
		V _{FG} (L)	I _{OUT} = -1 mA FG	—	0.2	1.0		
Output leakage current		I _L (H)	V _{OUT} = 0 V	—	0	1	μA	
		I _L (L)	V _{OUT} = 24 V	—	0	1		
Current detection		V _{RS}	RS	0.46	0.5	0.54	V	
Input delay		T _{RS}	RS → Output off	—	2.0	—	μs	
Gain-controlling amplifier for lead-angle controller		AMP _{OUT}	G _{OUT} output current, I _{OUT} = 5 mA, G _{IN} = 0.2 V G _{IN} , G _{OUT} : Gain = 12 (11 kΩ/1 kΩ)	2.25	2.3	—	V	
		AMP _{OFS}	G _{IN} , G _{OUT} 11 kΩ/1 kΩ	—	-40	—	mV	
Voltage error for lead-angle limit control		ΔL	LL = 0.7 V	-20	—	20	mV	
		ΔU	UL = 2.0 V	-30	—	30		
PH output current for lead-angle controller		PH _{OUT} (0 mA)	PH output current, I _{OUT} = 0 mA, G _{OUT} = 2.4 V	2.35	2.4	2.45	V	
		PH _{OUT} (5 mA)	PH output current, I _{OUT} = 5 mA, G _{OUT} = 2.4 V	—	1.9	—		
Lead angle correction		T _{LA} (0)	LA = 0 V or Open, Hall IN = 100 Hz	—	0	—	°	
		T _{LA} (1.5)	LA = 1.5 V, Hall IN = 100 Hz	—	15	—		
		T _{LA} (3)	LA = 3 V, Hall IN = 100 Hz	—	29	—		
Automatic restart from motor lock		T _{ML} (ON)	Lock detection time TR = 180 pF	—	500	—	ms	
		T _{ML} (OFF)	Output off time ML = High TR = 180 pF	—	500	—		
		F _{TR}	Oscillation frequency TR = 180 pF	1.5	2.0	2.5		kHz
VM power supply monitor		VM (H)	Output start point	3.8	4.0	4.2	V	
		VM (L)	Output stop point	3.3	3.5	3.7		
		VH	Hysteresis width	—	0.5	—		
PWM frequency		FC (5M)	OSC/C = 150 pF OSC/R = 16 kΩ	18	20	22	kHz	
Thermal shutdown		TSD	(Note)	150	165	180	°C	
		TSD _{hys}	Thermal shutdown hysteresis	—	15	—		

Note: Product testing before shipment is not performed.

Functional Description

1. Basic Operation

At startup, the motor is driven by a square-wave commutation signal that is generated based on the position detection signal. When the position detection signal exceeds the rotational frequency of $f = 2.5$ Hz, the rotor position is determined by the position detection signal and the modulated wave signal is generated. Then, the sine-wave PWM signal is generated by comparing the modulated wave signal with the triangular wave signal to start a motor in PWM drive mode.

Startup to 2.5 Hz: Square-wave drive (120° commutation) $f = f_{osc}/(2^{13} \times 41 \times 6)$
 2.5 Hz or higher: Sine-wave PWM drive (180° commutation) $f \approx 2.5$ Hz when $f_{osc} = 5$ MHz

2. Speed Control Input (V_{SP})

- (1) Speed control input: $0\text{ V} < V_{SP} \leq 0.5\text{ V}$
 The motor-driving output is turned off. (Motor is stopped.)
- (2) Speed control input: $V_{SP} > 0.5\text{ V}$
 When $f_{osc} = 5$ MHz, the motor is driven by a square wave until f reaches 2.5 Hz. Then, the motor-driving signal is switched to a sine-wave signal.

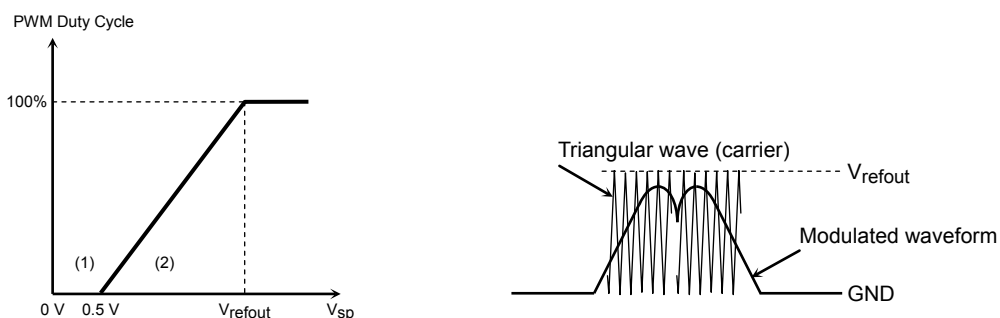

Note: An amplitude of the modulated waveform becomes maximum when $V_{SP} = V_{refout}$. The PWM duty cycle that is obtained with the V_{SP} voltage of V_{refout} is defined as 100%.

3. Carrier Frequency Setting

The frequency of the triangular wave (carrier frequency) required for the PWM signal generation is fixed at the following value:

$$f_c = f_{osc}/252 \text{ (Hz)}, \text{ where } f_{osc} = \text{Reference clock frequency (RC oscillator frequency)}$$

Example: When $f_{osc} = 5$ MHz, $f_c = 19.8$ kHz

4. Lead Angle Correction

The lead angle of the motor driving signal generated in accordance with the induced voltage (Hall signal) is corrected by an angle between 0 and 29°.

The lead angle control can be achieved by directly applying a voltage to the PA pin, or by using the motor current.

<Simplified Diagram of the LA Pin>

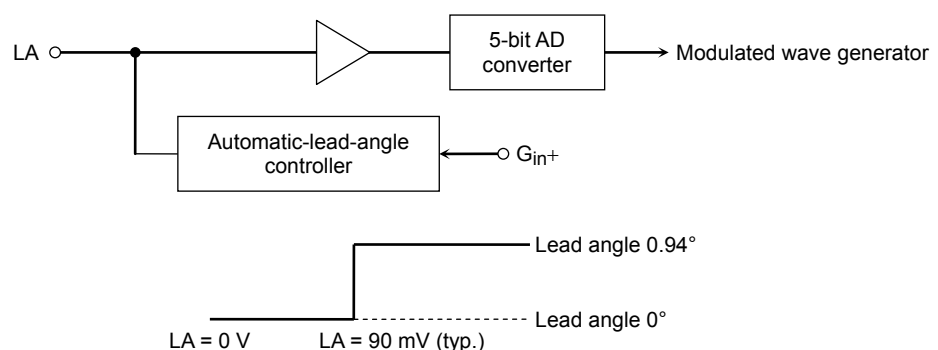

<Typical Characteristics of the LA versus Lead Angle>

Step	LA (V)	Lead angle (°)	Step	LA (V)	Lead angle (°)
1	0.00	0.00	17	1.50	15
2	0.09	0.94	18	1.59	15.94
3	0.19	1.88	19	1.69	16.88
4	0.28	2.81	20	1.78	17.81
5	0.38	3.75	21	1.88	18.75
6	0.47	4.69	22	1.97	19.69
7	0.56	5.63	23	2.06	20.63
8	0.66	6.56	24	2.16	21.56
9	0.75	7.5	25	2.25	22.50
10	0.84	8.44	26	2.34	23.44
11	0.94	9.38	27	2.44	24.38
12	1.03	10.31	28	2.53	25.31
13	1.13	11.25	29	2.63	26.25
14	1.22	12.19	30	2.72	27.19
15	1.31	13.13	31	2.81	28.13
16	1.41	14.06	32	2.91	29.06

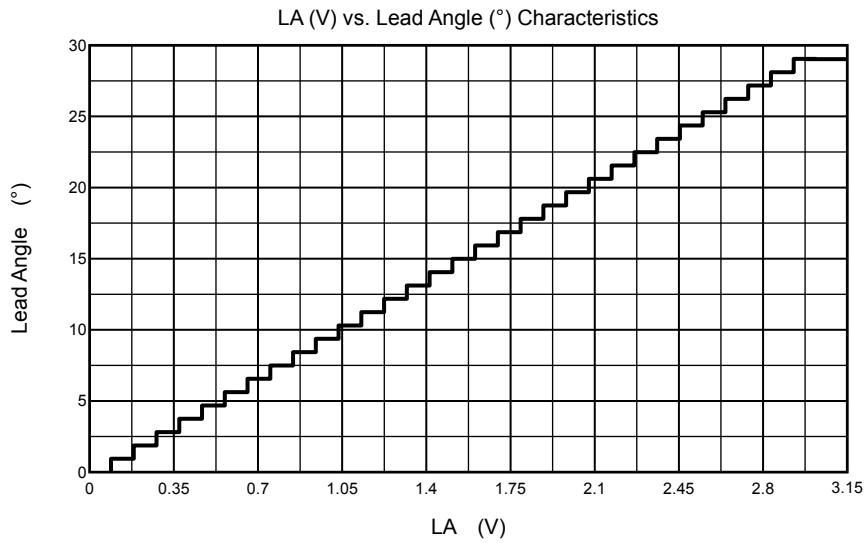

<Simplified Diagram of the Automatic-Lead-Angle Correction Circuitry>

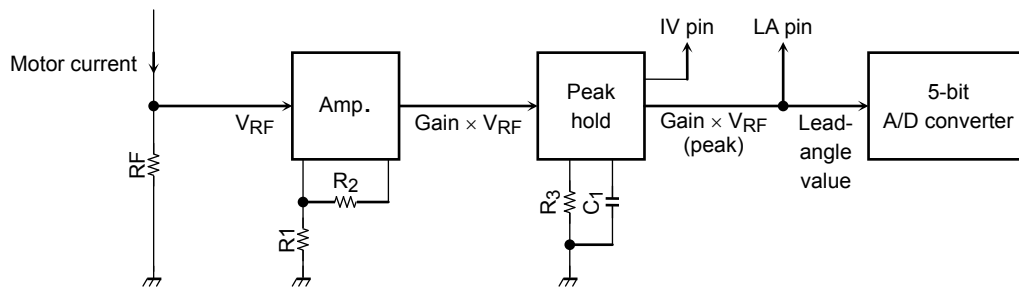

*: Gain = (R₁ + R₂) / R₁, R₃ = 100 kΩ, C₁ = 0.1 μF

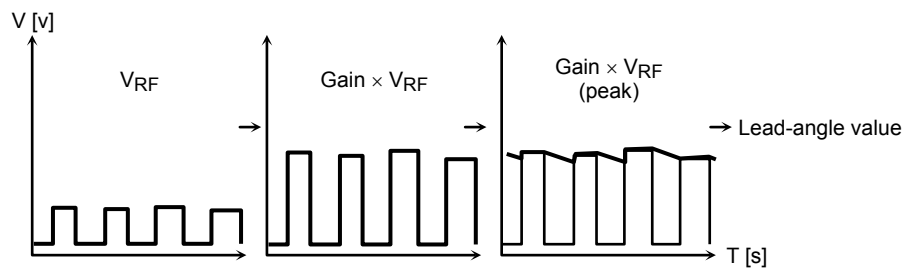

5. Position Detection (Hall effect input)

The in-phase input voltage range, V_{CMRH}, is from 1.5 to 3.5 V. The input hysteresis, V_H, is 8 mV (typ.).

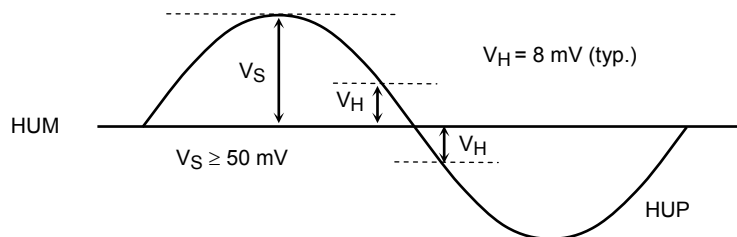

*: The Hall amplifier can operate when V_S is at least 50mVpp. However, to stabilize the time interval between zero-cross points of each phase signal, that is, the 60-electrical-degree interval, the amplitude should be as high as possible. (V_S is recommended to be 200 mVpp or higher.)

6. Rotation Pulse Output (FG output)

This pin generates a rotation pulse (3 pulses/electrical degree).

Example: With an eight-pole motor, 12 pulses are generated per revolution. (12 ppr)

7. Reverse Rotation Detection

The direction of the motor rotation is detected. The drive mode is then selected between 120° commutation and 180° commutation modes.

The detection is performed at every electrical degree of 360°.

CW/CCW Pin	Actual Rotation Direction of the Motor	Commutation Mode
Low (CW)	CW (clockwise)	180° commutation
	CCW (counterclockwise)	120° commutation
High (CCW)	CW (clockwise)	120° commutation
	CCW (counterclockwise)	180° commutation

Note: When the Hall signal frequency is below 2.5 Hz, the TB6585AFTG is put in 120° commutation mode even when 180° commutation mode is selected.

8. Various Protections

- (1) Overcurrent Protection (RS pin)
When a DC link current exceeds the internal reference voltage, output transistors are turned off. The TB6585AFTG exits overcurrent protection mode every carrier cycle. Reference voltage = 0.5 V (typ.)
- (2) External RESET (RESET pin)
Output transistors are turned off when RESET is High; they are turned on again when RESET is Low or Open.
The RESET pin is activated if any abnormality is detected externally.
- (3) Internal Protections
 - Position Detection Fault Protection
When the position detection signals are all set to High or Low, output transistors are turned off. Otherwise, the motor is restarted every carrier cycle.
 - Anti-lock capability
When the operation mode is not properly switched as configured from 120° commutation mode of startup operation to 180° commutation mode, the motor is deemed to be locked and output transistors are turned off. The restart operation can be selected from either the automatic restart or the power cycling.

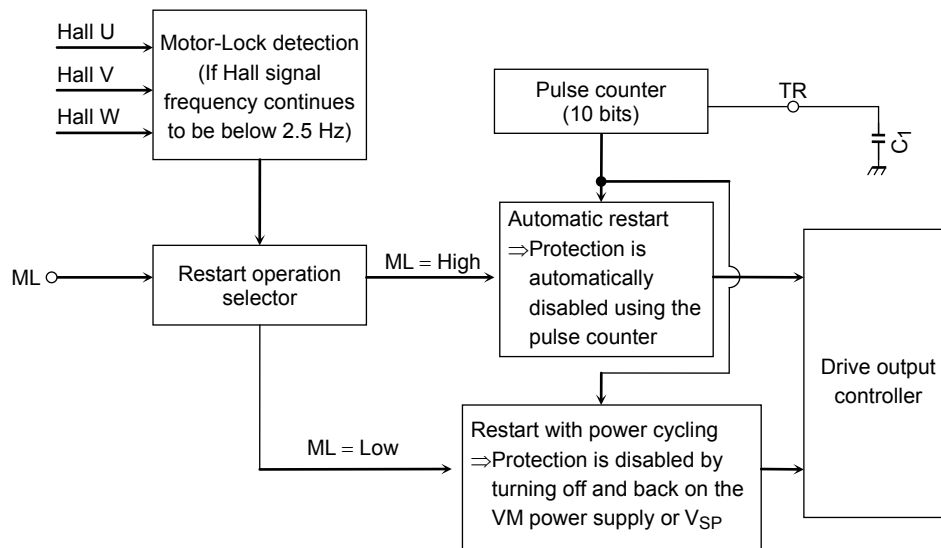

<Setting the Time of Motor-Lock Detection and the Time While the Motor is Stationary>

The time required for the motor-lock detection and the time while the motor driving signal is inactive can be adjusted by the external capacitor C₁. (These periods are set to be the same.)

$$\text{Time setting} \quad T = \frac{C_1 \times V_{th}}{I} \times 1024(\text{s}) \quad I = 0.72 \mu\text{A}, V_{th} = 2 \text{ V}$$

Example: When C₁ = 180 pF, T ≈ 500 ms (typ.).

<Automatic Restart (ML = High)>

When the Hall signal frequency is kept below 2.5 Hz for at least 500 ms (typ.), the TB6585AFTG becomes active and inactive periodically every 500 ms (typ.). The protection is disabled when the Hall signal frequency reaches 2.5 Hz and the operation mode is switched to 180° commutation mode.

<Restart with Power Cycling (ML = Open or Low)>

When the Hall signal frequency is kept below 2.5 Hz for at least 500 ms (typ.), output transistors are disabled. The TB6585AFTG can be restarted by turning off and back on the VM power supply, which must be kept below 3.5 V (typ.). The TB6585AFTG can also be restarted by turning off and back on V_{SP}, which must be kept below 0.5 V (typ.).

- Undervoltage Protection (VM Power Supply Monitoring)
When the VM power supply is turned on or off, commutation signal outputs are disabled while VM is outside the operating voltage range.

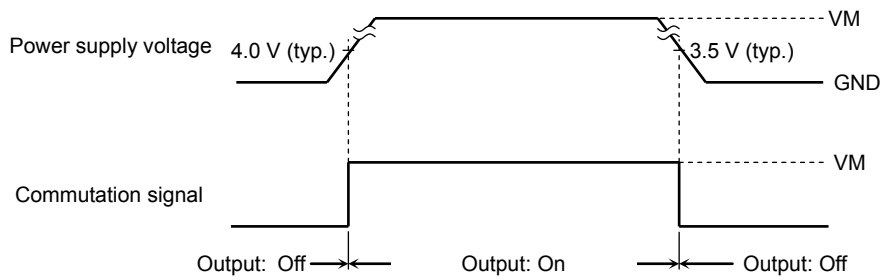

Operation Flow

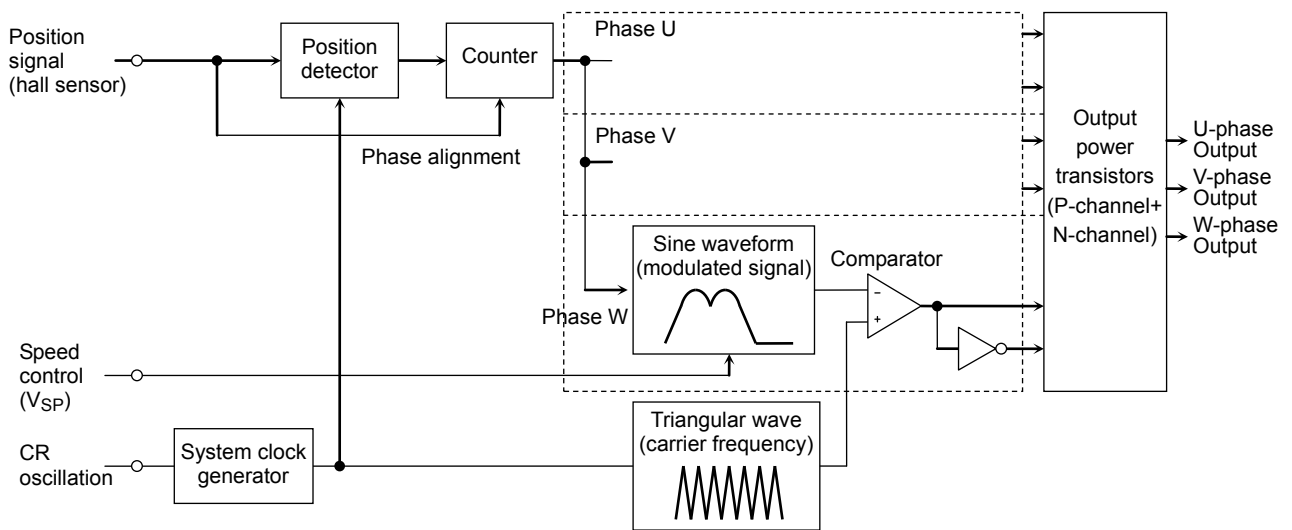

<Sine-Wave PWM Signal Generation>

The modulated waveform is generated using the Hall signals. The sine-wave PWM signal is then generated by comparing the modulated waveform with the triangular wave.

The time between the rising edges (falling edges) and the immediately-following falling edges (rising edges) of any of the three Hall signals (interval of 60 electrical degrees) are calculated by the counter. This period is used for data generation of the next 60-electrical-degree interval.

The modulated waveform of 60-electrical-degree interval consists of 32 data items. The time period for a single data item is 1/32 of the previous 60-electrical-degree interval. The modulated waveform advances by this period. (Operating waveforms when CW/CCW = Low)

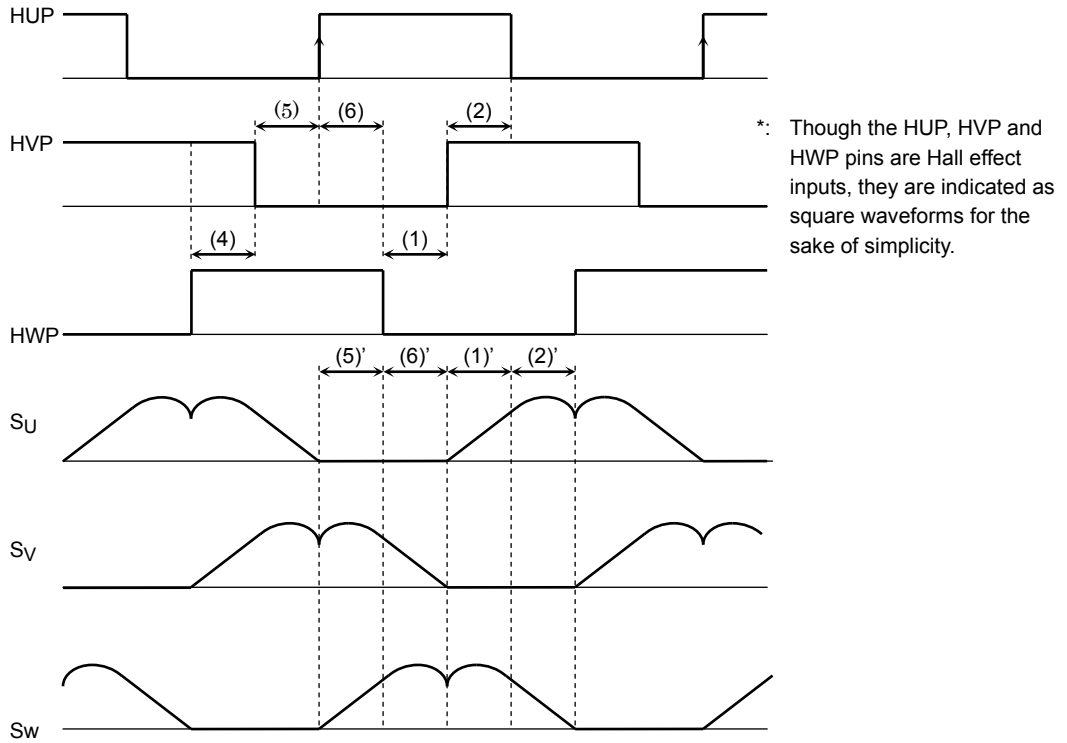

As illustrated above, the modulated waveform (1)' advances by 1/32 of the period between the rising edge (↑) of HU and the falling edge (↓) of HW. Likewise, the modulated waveform (2)' advances by 1/32 of the period between the falling edge (↓) of HW and the rising edge (↑) of HV.

If the next edge does not occur even after completing the generation of 32 data, data for the next 60-electrical-degree interval are generated based on the same time period until the next edge occurs.

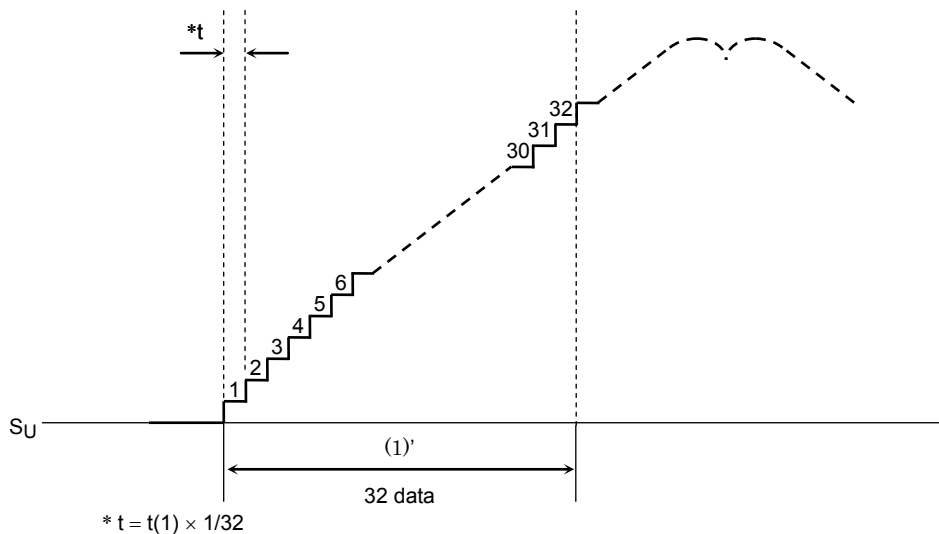

Also, the phase alignment with the modulated waveform is performed at every zero-cross point. The

modulated waveform is reset by being synchronized with the rising and falling edges of the position detection signal at every 60 electrical degrees. Therefore, the modulated waveform becomes discontinuous at every reset if there occurs a zero-cross point error of the Hall signal, or when motor is being accelerated or decelerated.

Also, the phase alignment with the modulated waveform is performed at every zero-cross point.

The modulated waveform is reset by being synchronized with the rising and falling edges of the position detection signal (Hall amplifier output) at every 60 electrical degrees.

Therefore, if the next zero-cross point occurs before completing the generation of 32 data for 60-electrical-degree interval due to the zero-cross point error of the position detection signal, the current data is reset and the data generation for the next 60-electrical-degree interval is then started.

In such cases, the modulated waveform is discontinuous at every reset.

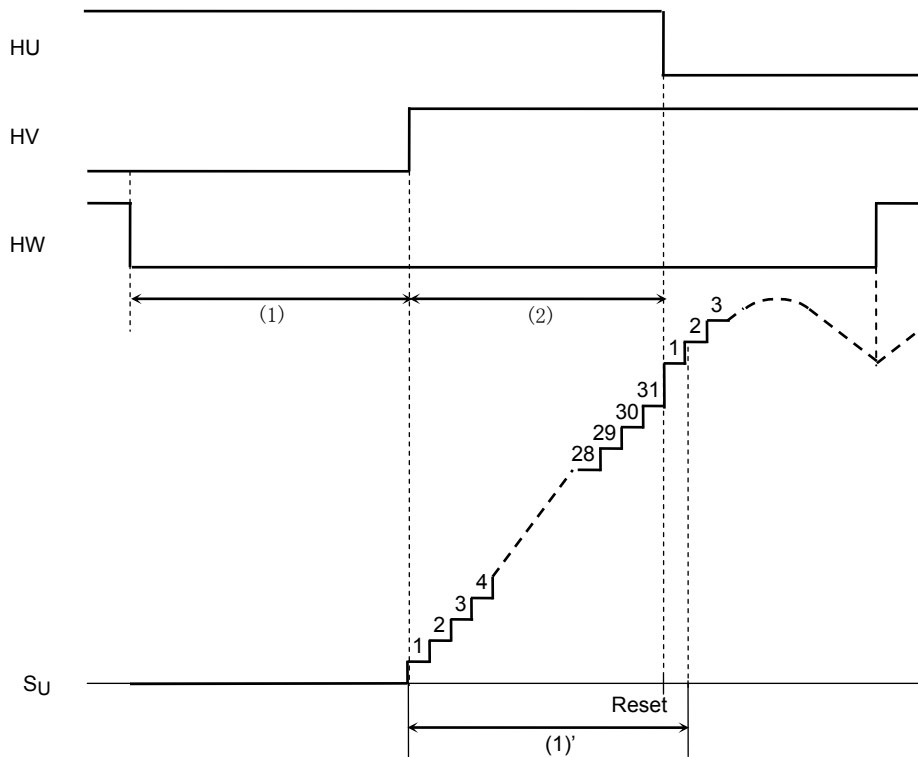

<Output Waveform of the Sine-Wave PWM Drive>

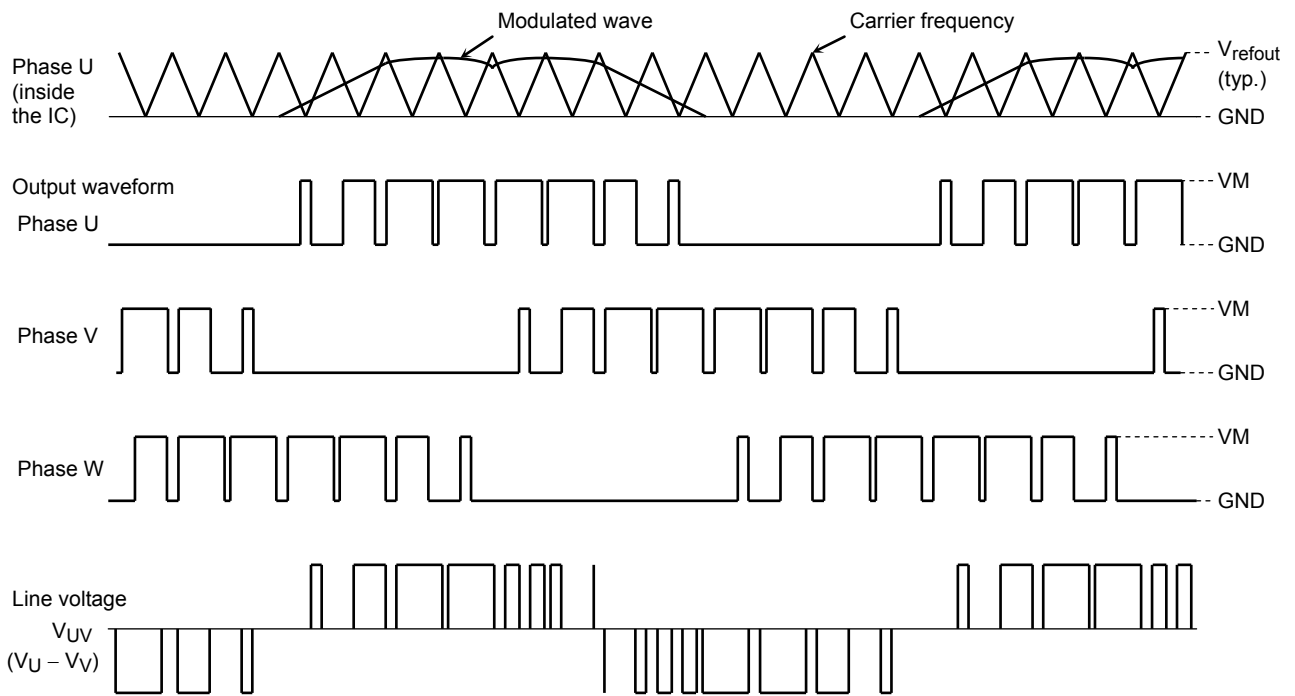

<Output Waveform of the Square-Wave Drive>

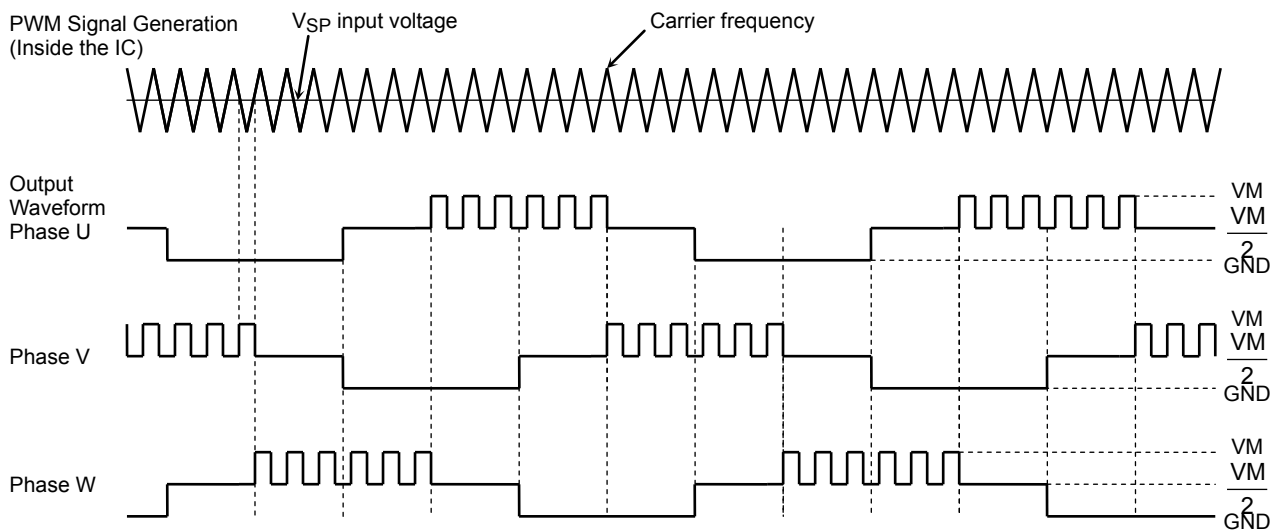

Note: The above U-phase waveform shows the behavior of the U-phase output signal when a resistor is connected between the U and V_M pins and also between the U pin and ground to obtain $\frac{V_M}{2}$. Likewise, resistors are connected to the V and W pins. $\frac{V_M}{2}$ indicates the high-impedance state.

Timing Chart of the Clockwise Rotation (CW/CCW = Low, LA = GND)

(Hall Signal Input for Clockwise Rotation)

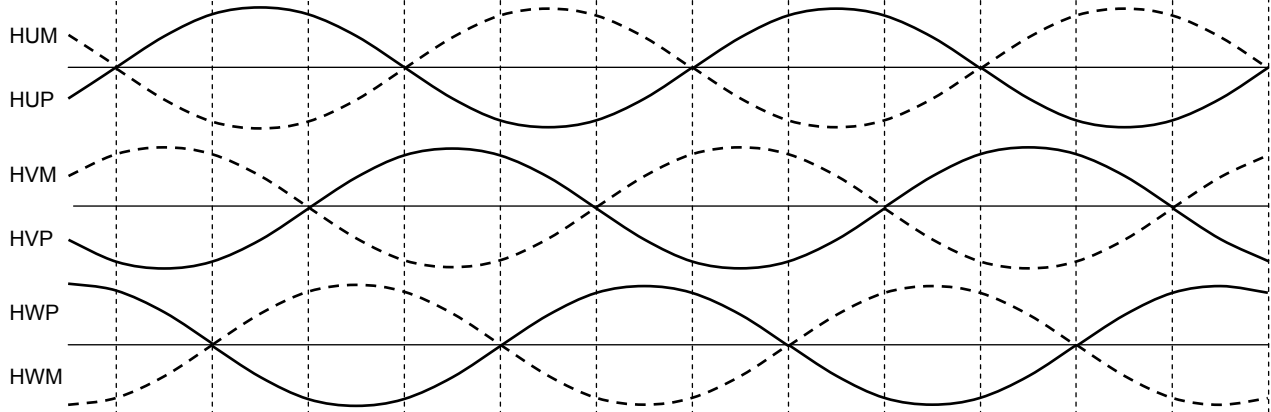

0 < Hall signal frequency < 2.5 Hz
(120° commutation: inside the IC)

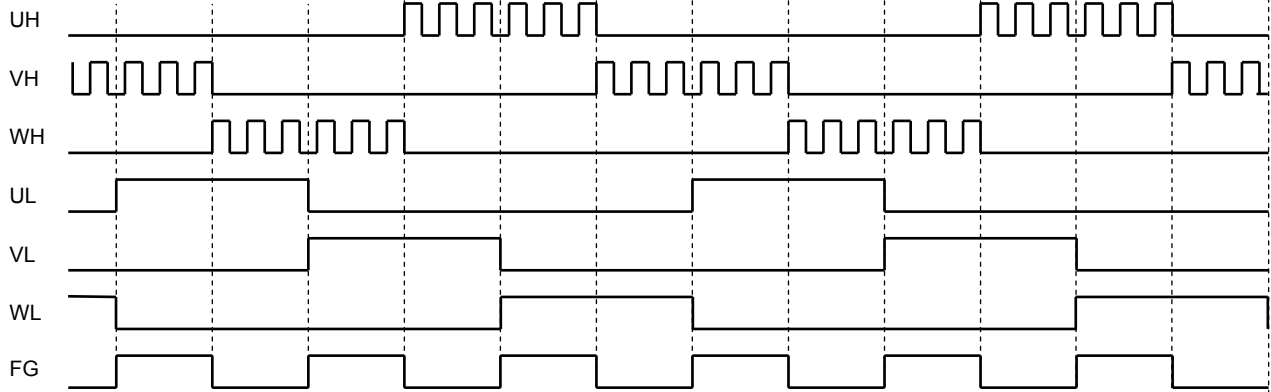

2.5 Hz < Hall signal frequency
(180° commutation: Modulated wave inside the IC)

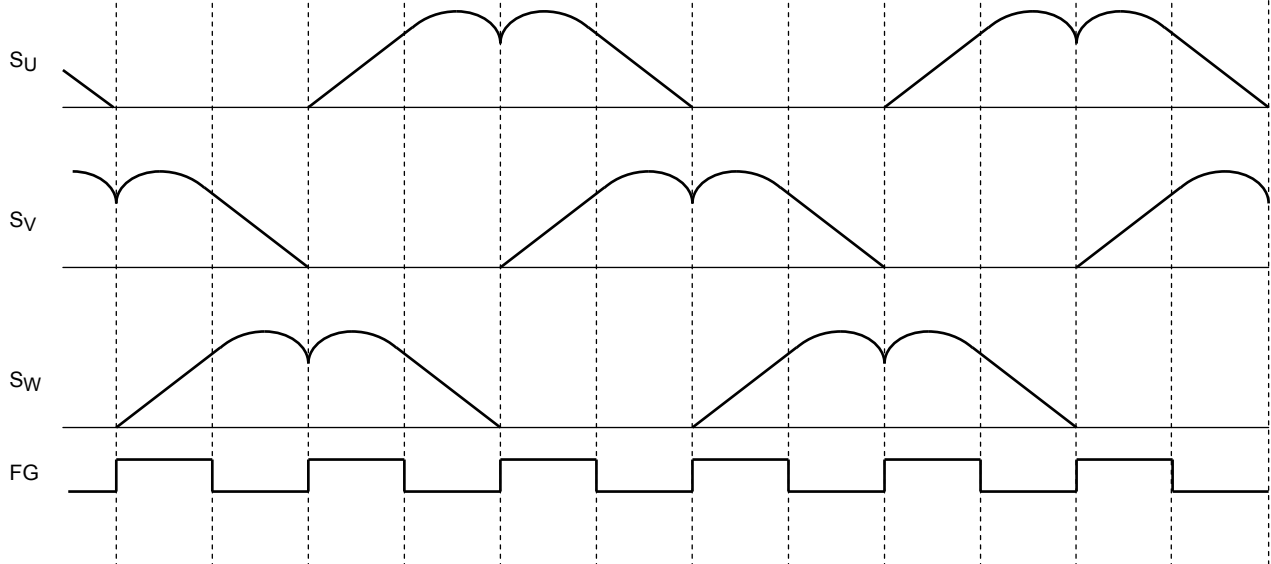

*: The lead-angle correction is performed in accordance with the LA input when the Hall signal frequency is 2.5 Hz or higher.

The timing chart may be simplified for the sake of brevity.

Timing Chart of the Clockwise Rotation (CW/CCW = Low, LA = GND)

(Hall Signal Input for Counterclockwise Rotation)

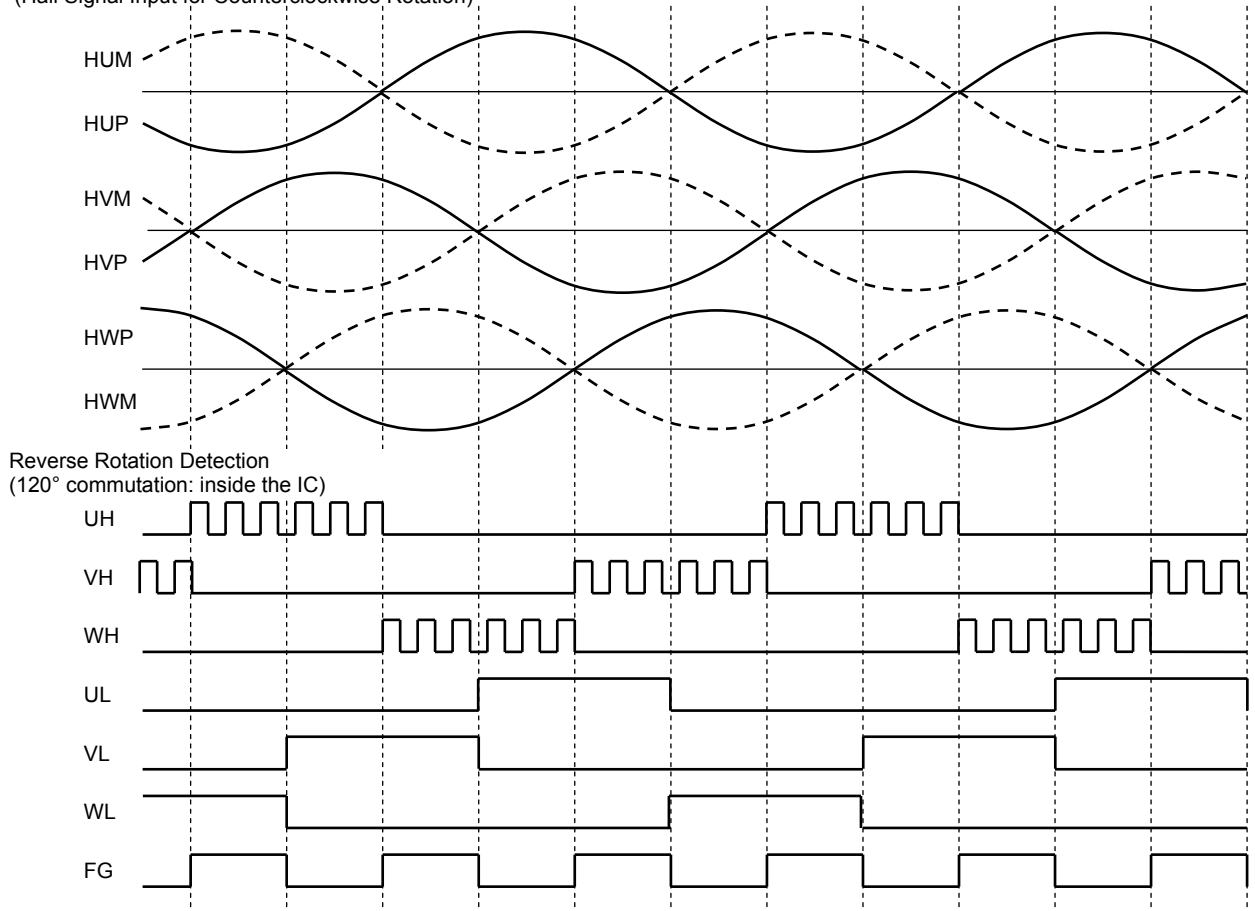

*: If the Hall signal for counterclockwise rotation is applied when CW/CCW = Low, the motor is driven by the 120° commutation signal with a lead angle of 0°. (Reverse rotation by the wind)

The timing chart may be simplified for the sake of brevity.

Timing Chart of the Counterclockwise Rotation (CW/CCW = High, LA = GND)

(Hall Signal Input for Counterclockwise Rotation)

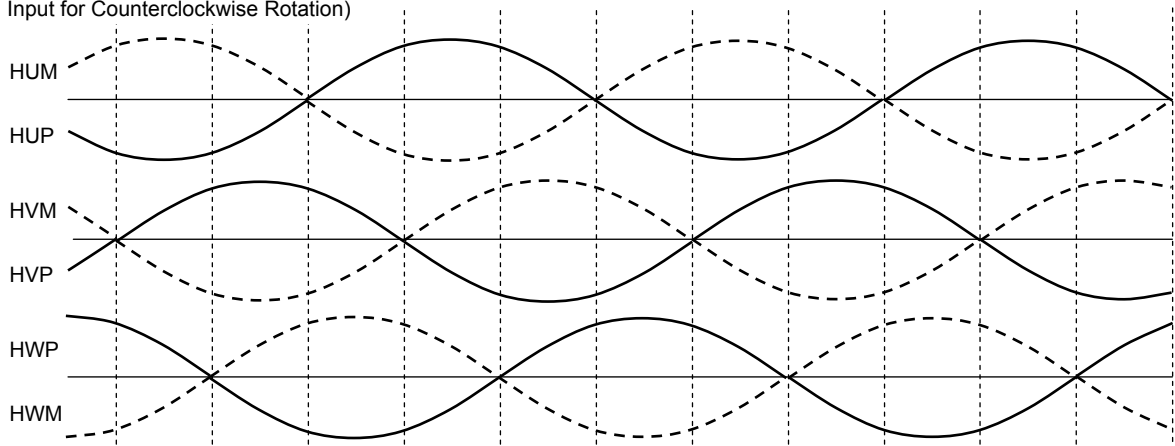

0 < Hall signal frequency < 5 Hz
(120° commutation: inside the IC)

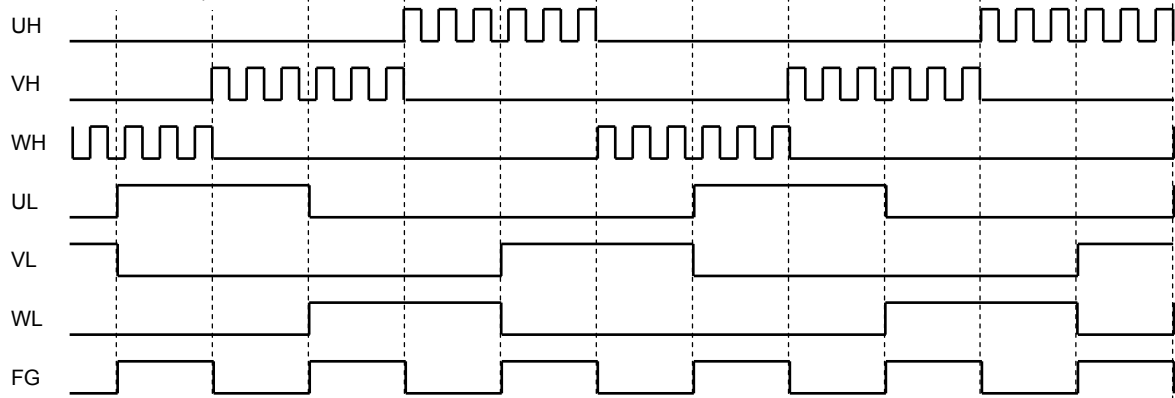

5 Hz < Hall signal frequency
(180° commutation: Modulated wave inside the IC)

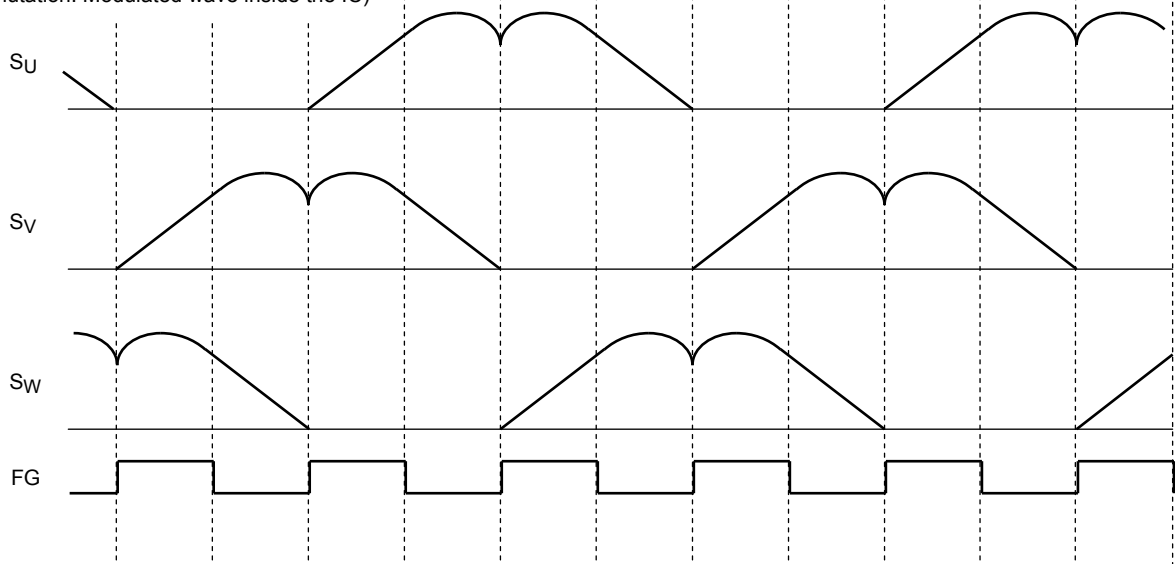

*: The lead-angle correction is performed in accordance with the LA input when the Hall signal frequency is 2.5 Hz or higher.

The timing chart may be simplified for the sake of brevity.

Timing Chart of the Counterclockwise Rotation (CW/CCW = High, LA = GND)

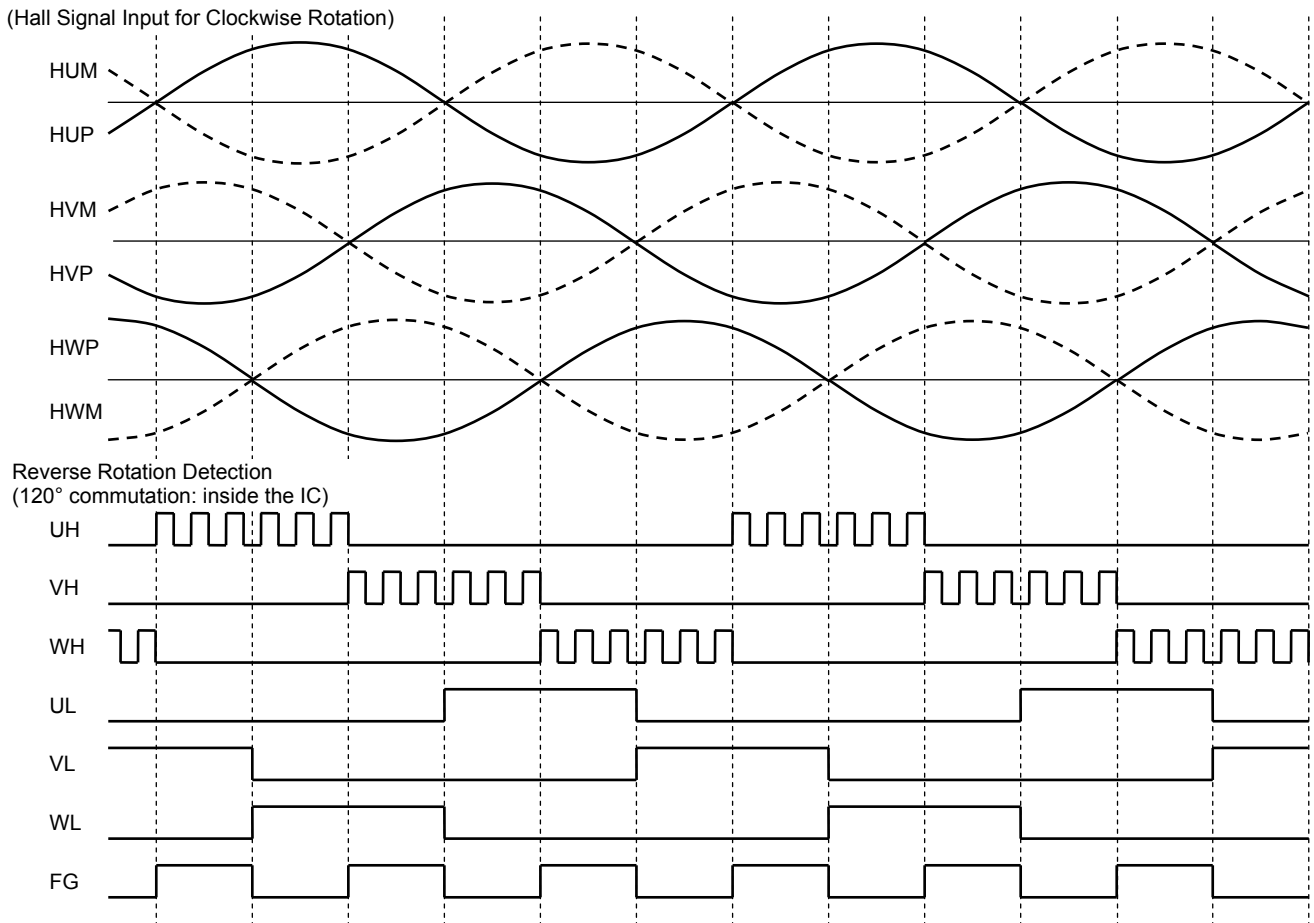

*: If the Hall signal for clockwise rotation is applied when CW/CCW = High, the motor is driven by the 120° commutation signal with a lead angle of 0°. (Reverse rotation by the wind)

The timing chart may be simplified for the sake of brevity.

Block Diagram

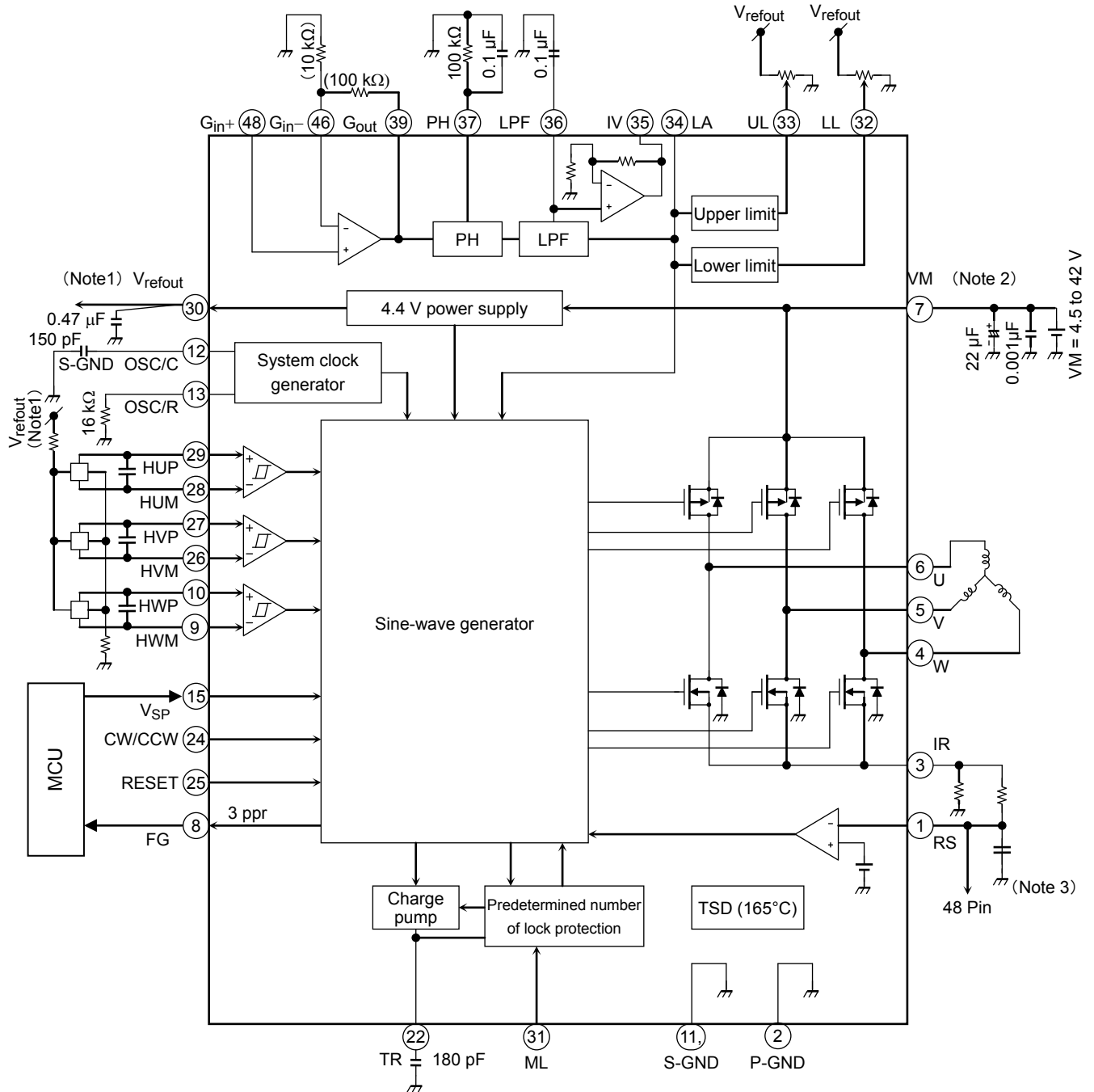

Note 1: An oscillation prevention capacitor should be connected to the V_{refout} pin at a location as close to the TB6585AFTG as possible.

If the package's thermal performance is not enough for the application, a load must not be connected to the V_{refout} output; instead, a voltage of 4.4 V must be applied externally to it.

Note 2: An oscillation prevention capacitor should be connected to the VM pin at a location as close to the TB6585AFTG as possible.

Note 3: If there is a significant noise, an RC filter (low-pass filter) should be connected.

Note: A large current or voltage might be abruptly applied to the IC and peripherals in case of a short-circuit across outputs, a short-circuit to power supply or a short-circuit to ground. This possibility should be fully considered in the design of the output, VM, IR and ground lines. Also, care should be taken not to install the IC in the wrong orientation. Otherwise, IC may be broken.

Note: The constants of loads that are connected externally to the IC shown in the above diagram are used as initial values to determine whether the application operates properly. The capacitor values that are connected to VM, V_{refout} , and between positive and negative inputs of Hall elements must be determined experimentally.

Notes on Contents

1. Block Diagrams

Some of the functional blocks, circuits, or constants in the block diagram may be omitted or simplified for explanatory purposes.

2. Equivalent Circuits

The equivalent circuit diagrams may be simplified or some parts of them may be omitted for explanatory purposes.

3. Timing Charts

Timing charts may be simplified for explanatory purposes.

4. Application Circuits

The application circuits shown in this document are provided for reference purposes only. Thorough evaluation is required, especially at the mass production design stage.

Toshiba does not grant any license to any industrial property rights by providing these examples of application circuits.

5. Test Circuits

Components in the test circuits are used only to obtain and confirm the device characteristics. These components and circuits are not guaranteed to prevent malfunction or failure from occurring in the application equipment.

IC Usage Considerations

Notes on handling of ICs

- (1) The absolute maximum ratings of a semiconductor device are a set of ratings that must not be exceeded, even for a moment. Do not exceed any of these ratings.
Exceeding the rating(s) may cause the device breakdown, damage or deterioration, and may result injury by explosion or combustion.
- (2) Use an appropriate power supply fuse to ensure that a large current does not continuously flow in case of over current and/or IC failure. The IC will fully break down when used under conditions that exceed its absolute maximum ratings, when the wiring is routed improperly or when an abnormal pulse noise occurs from the wiring or load, causing a large current to continuously flow and the breakdown can lead smoke or ignition. To minimize the effects of the flow of a large current in case of breakdown, appropriate settings, such as fuse capacity, fusing time and insertion circuit location, are required.
- (3) If your design includes an inductive load such as a motor coil, incorporate a protection circuit into the design to prevent device malfunction or breakdown caused by the current resulting from the inrush current at power ON or the negative current resulting from the back electromotive force at power OFF. IC breakdown may cause injury, smoke or ignition.
Use a stable power supply with ICs with built-in protection functions. If the power supply is unstable, the protection function may not operate, causing IC breakdown. IC breakdown may cause injury, smoke or ignition.
- (4) Do not insert devices in the wrong orientation or incorrectly.
Make sure that the positive and negative terminals of power supplies are connected properly. Otherwise, the current or power consumption may exceed the absolute maximum rating, and exceeding the rating(s) may cause the device breakdown, damage or deterioration, and may result injury by explosion or combustion.
In addition, do not use any device that is applied the current with inserting in the wrong orientation or incorrectly even just one time.

Points to Remember on Handling of ICs

(1) Over current protection circuit

Over current protection circuits (referred to as current limiter circuits) do not necessarily protect ICs under all circumstances. If the Over current protection circuits operate against the over current, clear the over current status immediately.

Depending on the method of use and usage conditions, such as exceeding absolute maximum ratings can cause the over current protection circuit to not operate properly or IC breakdown before operation. In addition, depending on the method of use and usage conditions, if over current continues to flow for a long time after operation, the IC may generate heat resulting in breakdown.

(2) Thermal shutdown circuit

Thermal shutdown circuits do not necessarily protect ICs under all circumstances. If the thermal shutdown circuits operate against the over temperature, clear the heat generation status immediately. Depending on the method of use and usage conditions, such as exceeding absolute maximum ratings can cause the thermal shutdown circuit to not operate properly or IC breakdown before operation.

(3) Heat radiation design

In using an IC with large current flow such as power amp, regulator or driver, please design the device so that heat is appropriately radiated, not to exceed the specified junction temperature (T_J) at any time and condition. These ICs generate heat even during normal use. An inadequate IC heat radiation design can lead to decrease in IC life, deterioration of IC characteristics or IC breakdown. In addition, please design the device taking into consideration the effect of IC heat radiation with peripheral components.

(4) Back-EMF

When a motor rotates in the reverse direction, stops or slows down abruptly, a current flow back to the motor's power supply due to the effect of back-EMF. If the current sink capability of the power supply is small, the device's motor power supply and output pins might be exposed to conditions beyond absolute maximum ratings. To avoid this problem, take the effect of back-EMF into consideration in system design.

RESTRICTIONS ON PRODUCT USE

- Toshiba Corporation, and its subsidiaries and affiliates (collectively "TOSHIBA"), reserve the right to make changes to the information in this document, and related hardware, software and systems (collectively "Product") without notice.
- This document and any information herein may not be reproduced without prior written permission from TOSHIBA. Even with TOSHIBA's written permission, reproduction is permissible only if reproduction is without alteration/omission.
- Though TOSHIBA works continually to improve Product's quality and reliability, Product can malfunction or fail. Customers are responsible for complying with safety standards and for providing adequate designs and safeguards for their hardware, software and systems which minimize risk and avoid situations in which a malfunction or failure of Product could cause loss of human life, bodily injury or damage to property, including data loss or corruption. Before customers use the Product, create designs including the Product, or incorporate the Product into their own applications, customers must also refer to and comply with (a) the latest versions of all relevant TOSHIBA information, including without limitation, this document, the specifications, the data sheets and application notes for Product and the precautions and conditions set forth in the "TOSHIBA Semiconductor Reliability Handbook" and (b) the instructions for the application with which the Product will be used with or for. Customers are solely responsible for all aspects of their own product design or applications, including but not limited to (a) determining the appropriateness of the use of this Product in such design or applications; (b) evaluating and determining the applicability of any information contained in this document, or in charts, diagrams, programs, algorithms, sample application circuits, or any other referenced documents; and (c) validating all operating parameters for such designs and applications. **TOSHIBA ASSUMES NO LIABILITY FOR CUSTOMERS' PRODUCT DESIGN OR APPLICATIONS.**
- **PRODUCT IS NEITHER INTENDED NOR WARRANTED FOR USE IN EQUIPMENTS OR SYSTEMS THAT REQUIRE EXTRAORDINARILY HIGH LEVELS OF QUALITY AND/OR RELIABILITY, AND/OR A MALFUNCTION OR FAILURE OF WHICH MAY CAUSE LOSS OF HUMAN LIFE, BODILY INJURY, SERIOUS PROPERTY DAMAGE AND/OR SERIOUS PUBLIC IMPACT ("UNINTENDED USE").** Except for specific applications as expressly stated in this document, Unintended Use includes, without limitation, equipment used in nuclear facilities, equipment used in the aerospace industry, Class 3 medical devices, equipment used for automobiles, and military vehicles and munitions. **IF YOU USE PRODUCT FOR UNINTENDED USE, TOSHIBA ASSUMES NO LIABILITY FOR PRODUCT.** For details, please contact your TOSHIBA sales representative or contact us via our website.
- Do not disassemble, analyze, reverse-engineer, alter, modify, translate or copy Product, whether in whole or in part.
- Product shall not be used for or incorporated into any products or systems whose manufacture, use, or sale is prohibited under any applicable laws or regulations.
- The information contained herein is presented only as guidance for Product use. No responsibility is assumed by TOSHIBA for any infringement of patents or any other intellectual property rights of third parties that may result from the use of Product. No license to any intellectual property right is granted by this document, whether express or implied, by estoppel or otherwise.
- **ABSENT A WRITTEN SIGNED AGREEMENT, EXCEPT AS PROVIDED IN THE RELEVANT TERMS AND CONDITIONS OF SALE FOR PRODUCT, AND TO THE MAXIMUM EXTENT ALLOWABLE BY LAW, TOSHIBA (1) ASSUMES NO LIABILITY WHATSOEVER, INCLUDING WITHOUT LIMITATION, INDIRECT, CONSEQUENTIAL, SPECIAL, OR INCIDENTAL DAMAGES OR LOSS, INCLUDING WITHOUT LIMITATION, LOSS OF PROFITS, LOSS OF OPPORTUNITIES, BUSINESS INTERRUPTION AND LOSS OF DATA, AND (2) DISCLAIMS ANY AND ALL EXPRESS OR IMPLIED WARRANTIES AND CONDITIONS RELATED TO SALE, USE OF PRODUCT, OR INFORMATION, INCLUDING WARRANTIES OR CONDITIONS OF MERCHANTABILITY, FITNESS FOR A PARTICULAR PURPOSE, ACCURACY OF INFORMATION, OR NONINFRINGEMENT.**
- Do not use or otherwise make available Product or related software or technology for any military purposes, including without limitation, for the design, development, use, stockpiling or manufacturing of nuclear, chemical, or biological weapons or missile technology products (mass destruction weapons). Product and related software and technology may be controlled under the applicable export laws and regulations including, without limitation, the Japanese Foreign Exchange and Foreign Trade Law and the U.S. Export Administration Regulations. Export and re-export of Product or related software or technology are strictly prohibited except in compliance with all applicable export laws and regulations.
- Please contact your TOSHIBA sales representative for details as to environmental matters such as the RoHS compatibility of Product. Please use Product in compliance with all applicable laws and regulations that regulate the inclusion or use of controlled substances, including without limitation, the EU RoHS Directive. **TOSHIBA ASSUMES NO LIABILITY FOR DAMAGES OR LOSSES OCCURRING AS A RESULT OF NONCOMPLIANCE WITH APPLICABLE LAWS AND REGULATIONS.**