

TOSHIBA Zener Diode Silicon Epitaxial Planar Type

CSLZ Series

1. Applications

Voltage surge protection

2. Features

Small package
The typical voltage of VZ is accorded to E24 series.

3. Packaging and Internal Circuit

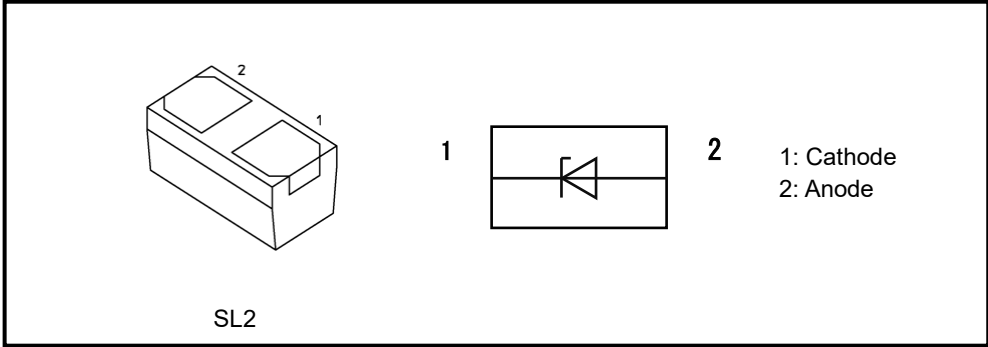

4. Absolute Maximum Ratings 1 (Note) (Unless otherwise specified, Ta = 25°C)

Characteristics	Symbol	Rating	Unit
Power dissipation	P_D ^{Note1}	150	mW
	P_D ^{Note2}	400	mW
Junction temperature	T_j	150	°C
Storage temperature	T_{stg}	-55 to 150	°C

5. Absolute Maximum Ratings 2 (Note) (Unless otherwise specified, Ta = 25°C)

Type No.	Electrostatic discharge Voltage ^{Note3}		Peak pulse power ^{Note4}	Peak pulse current ^{Note4}	Type No.	Electrostatic discharge Voltage ^{Note3}		Peak pulse power ^{Note4}	Peak pulse current ^{Note4}
	Contact	Air				Contact	Air		
	VESD(kV)					VESD(kV)			
		PPK(W)	I _{PP} (A)			PPK(W)	I _{PP} (A)		
CSLZ5V6	± 30		32	2.5	CSLZ12V	± 20		72	2.5
CSLZ6V2	± 30		37	2.5	CSLZ16V	± 12		87	2.5
CSLZ6V8	± 30		40	2.5	CSLZ20V	± 12		105	2.5
CSLZ8V2	± 30		55	2.5	CSLZ24V	± 10		117	2.5
CSLZ10V	± 30		60	2.5	CSLZ30V	± 8		145	2.5

Note: Using continuously under heavy loads (e.g. the application of high temperature/current/voltage and the significant change in temperature, etc.) may cause this product to decrease in the reliability significantly even if the operating conditions (i.e. operating temperature/current/voltage, etc.) are within the absolute maximum ratings. Please design the appropriate reliability upon reviewing the Toshiba Semiconductor Reliability Handbook (“Handling Precautions”/“Derating Concept and Methods”) and individual reliability data (i.e. reliability test report and estimated failure rate, etc).

Note1: Mounted on a glass epoxy circuit board of 20 mm × 20 mm, pad dimensions of 4 mm × 4 mm.

Note 2: Mounted on a glass epoxy circuit board of 25.4 mm × 25.4 mm × 1.6 mmt, Cu pad: 645 mm²

Note 3: according to IEC61000-4-2

Note 4: according to IEC61000-4-5, tp = 8 / 20 μs

Start of commercial production
2022-04

6. Electrical Characteristics (Unless otherwise specified, $T_a = 25\text{ }^\circ\text{C}$)

Type No.	Zener Voltage			Test Current I_Z (mA)	Dynamic Impedance		Dynamic resistance R_{DYN} (Ω) Note1	Clamp voltage V_C (V) Note1, Note2	Total capacitance C_t (pF) Note3	Reverse Current	
	V_Z (V)				Z_Z (Ω)	Test Current I_Z (mA)				I_R (μA)	Test Voltage V_R (V)
	Min	Typ.	Max	Max							
CSLZ5V6	5.3	5.6	6.0	5	30	5	0.25	9	35	1.0	3.5
CSLZ6V2	5.8	6.2	6.6	5	30	5	0.38	10.5	30	2.5	5.0
CSLZ6V8	6.4	6.8	7.2	5	30	5	0.5	14.5	25	0.5	5.0
CSLZ8V2	7.7	8.2	8.7	5	30	5	0.62	17	18	0.5	6.5
CSLZ10V	9.4	10	10.6	5	30	5	0.5	18	16	0.5	8.0
CSLZ12V	11.4	12	12.6	5	30	5	1.5	28	13	0.5	9
CSLZ16V	15.3	16	17.1	5	35	5	1.7	30	10.5	0.5	12
CSLZ20V	18.8	20	21.2	5	50	5	2.5	30	9.5	0.5	15
CSLZ24V	22.8	24	25.6	5	70	5	1.5	34	8.5	0.5	19
CSLZ30V	28	30	31.5	2	150	2	4	51	7.5	0.5	23

Note1: TLP parameters: $Z_0 = 50\ \Omega$, $t_p = 100\ \text{ns}$, $t_r = 300\ \text{ps}$, averaging window: $t_1 = 30\ \text{ns}$ to $t_2 = 60\ \text{ns}$,

extraction of dynamic resistance using least squares fit of TLP characteristics between $I_{TLP1} = 8\ \text{A}$ and $I_{TLP2} = 16\ \text{A}$.

Note2: $I_{TLP} = 8\ \text{A}$

Note3: $V_R = 0\ \text{V}$, $f = 1\ \text{MHz}$

7. Marking List

Type No.	Marking	Type No.	Marking
CSLZ5V6		CSLZ12V	
CSLZ6V2		CSLZ16V	
CSLZ6V8		CSLZ20V	
CSLZ8V2		CSLZ24V	
CSLZ10V		CSLZ30V	

8. Marking (CSLZ5V6)

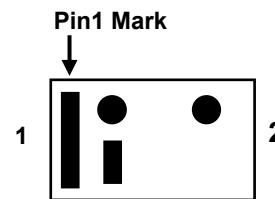

9. Land Pattern Dimensions (for reference only) (Unit: mm)

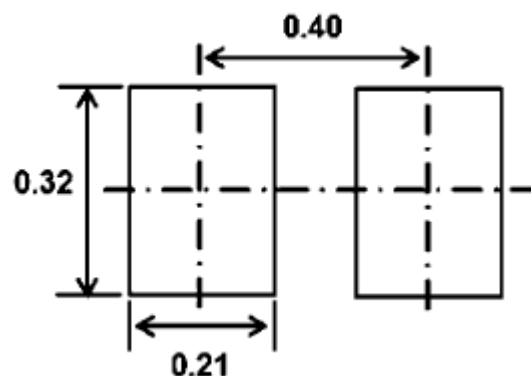

10. Characteristics Curves

10.1. CSLZ series Characteristics Curves (Note1)

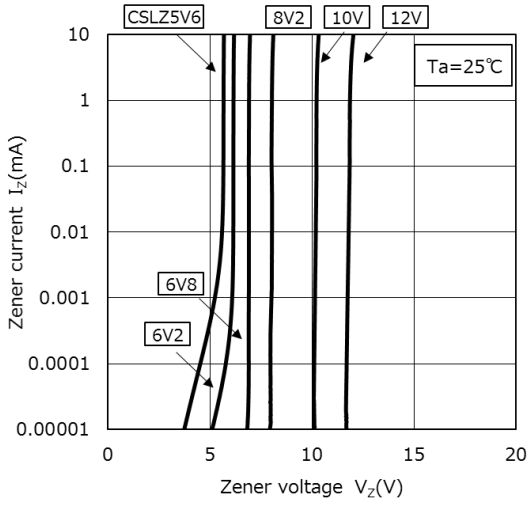

$I_z - V_z$ (1)

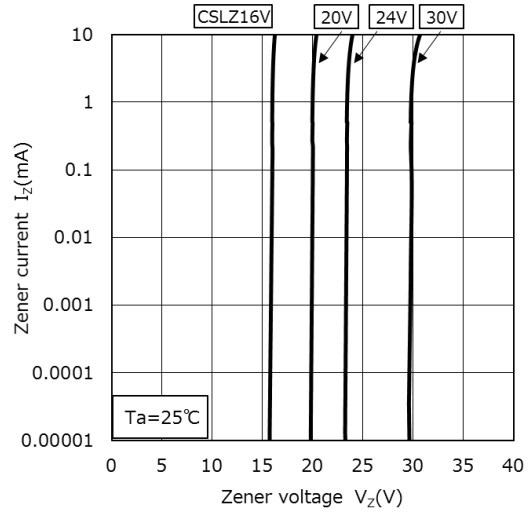

$I_z - V_z$ (2)

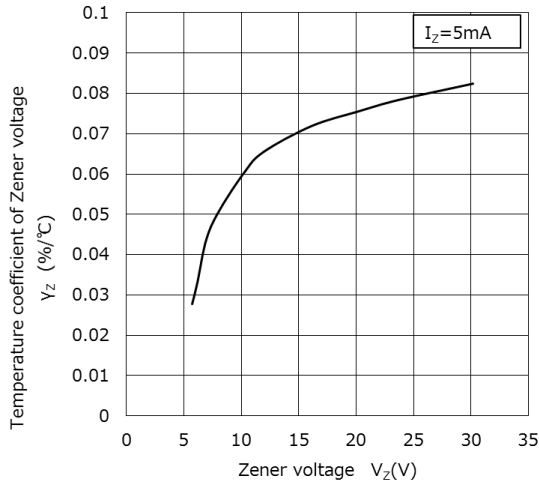

$Y_z - V_z$

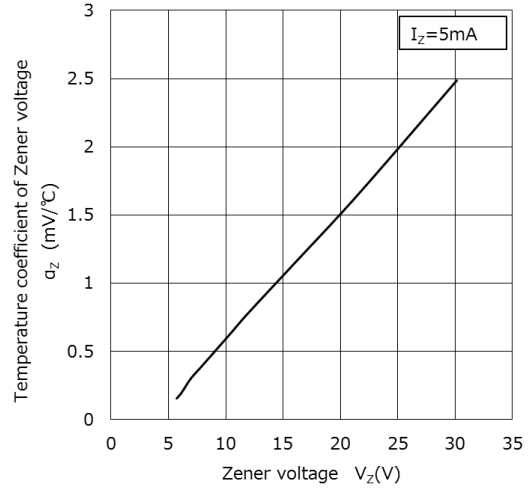

$\alpha_z - V_z$

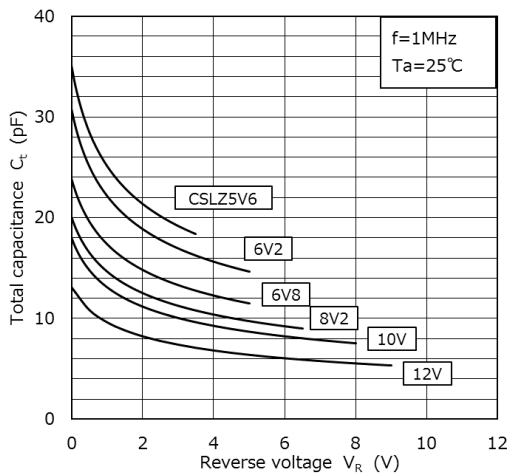

$C_t - V_R$ (1)

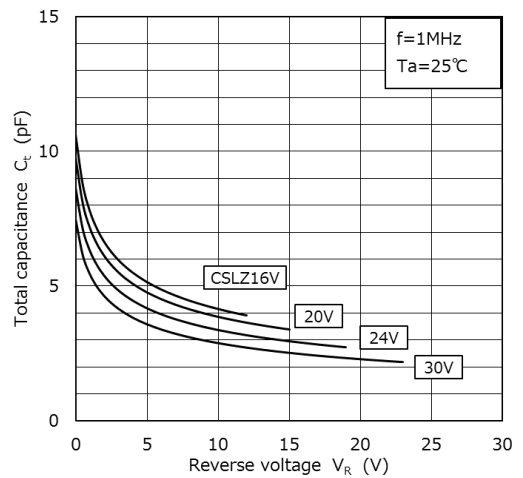

$C_t - V_R$ (2)

Note1: The above characteristics curves are presented for reference only and not guaranteed by production test, unless otherwise noted.

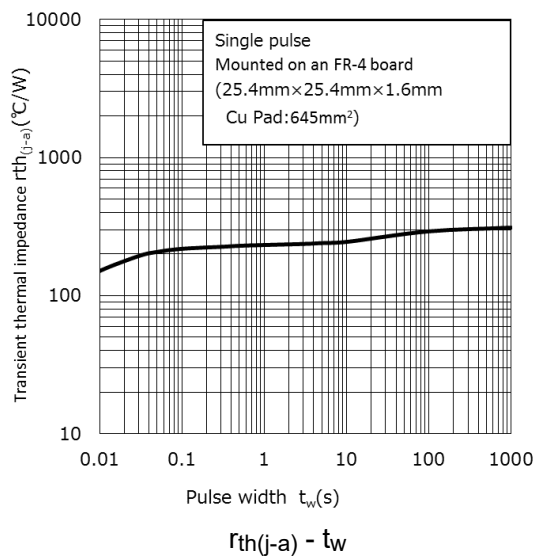
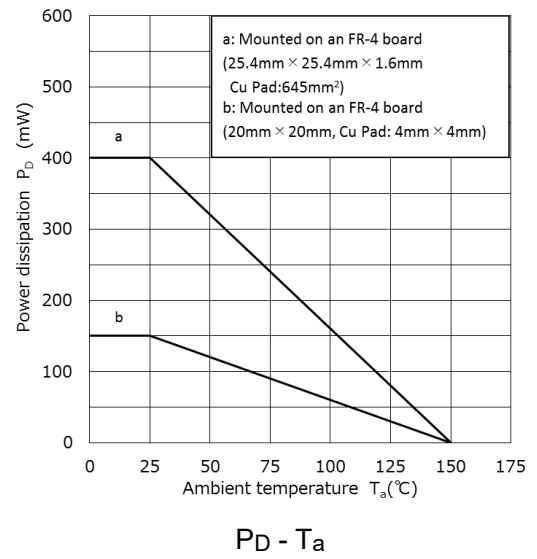
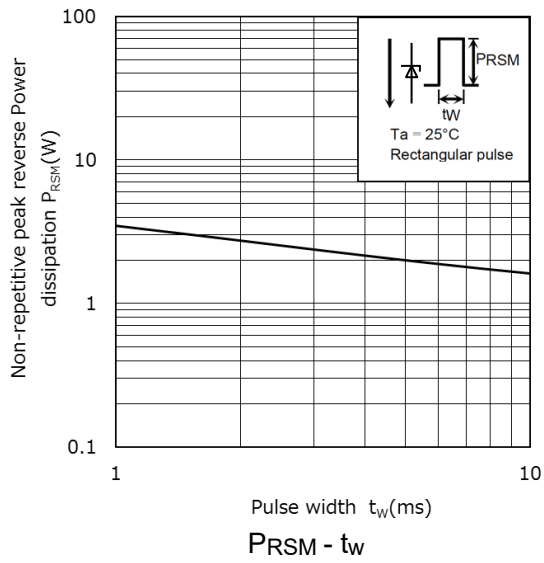

Note1: The above characteristics curves are presented for reference only and not guaranteed by production test, unless otherwise noted.

10.2. CSLZ5V6 Characteristics Curves (Note1)

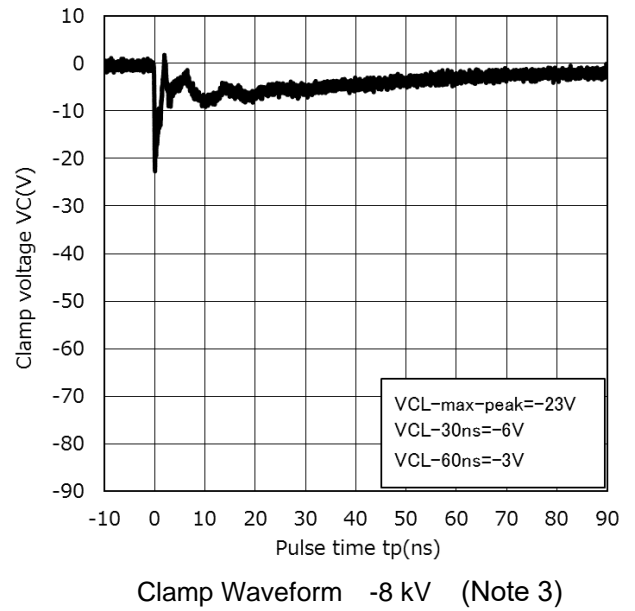
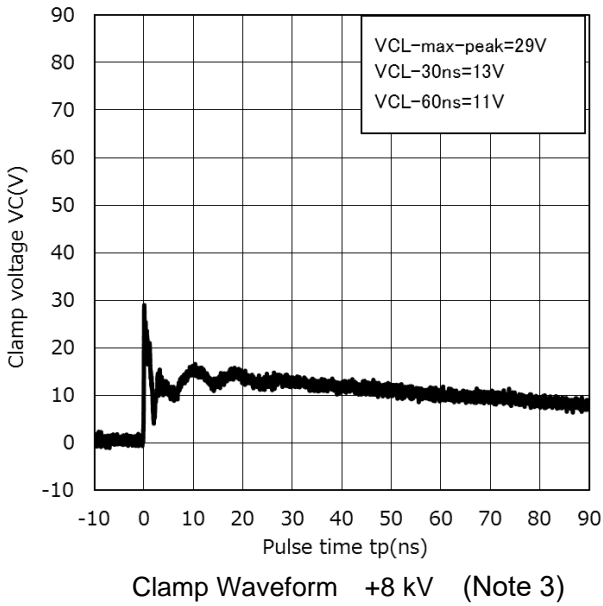
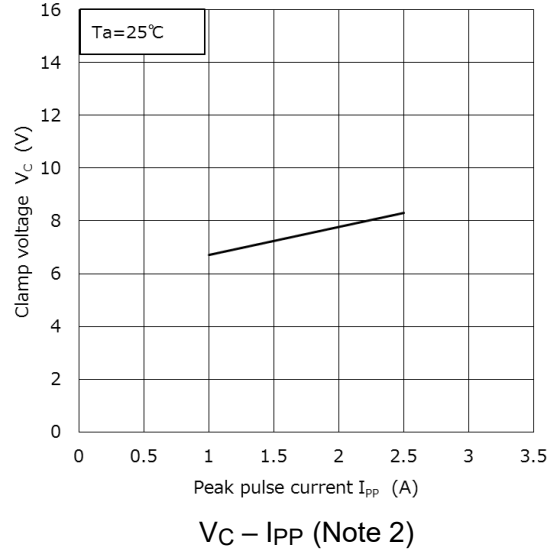
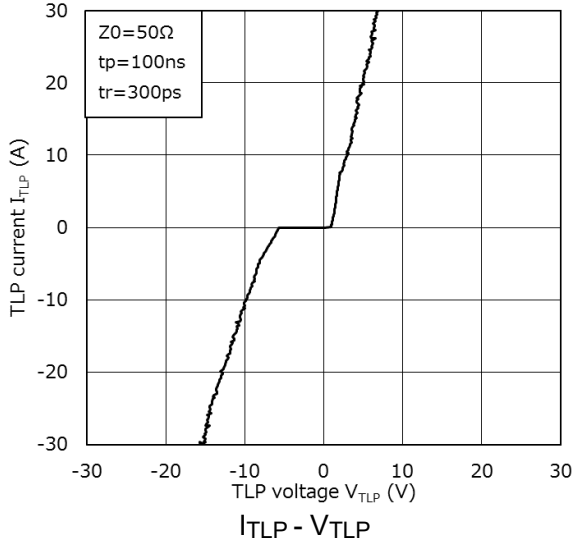

(Note 2) Peak Pulse Current ($V_C - I_{PP}$)

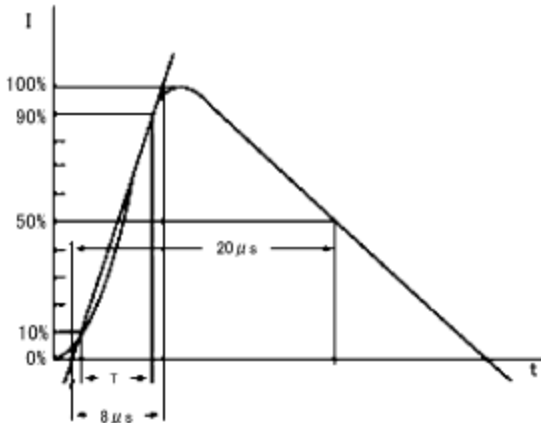

Based on IEC61000-4-5 8/20 μ s pulse..

(Note 3) Clamp waveform measurement circuit

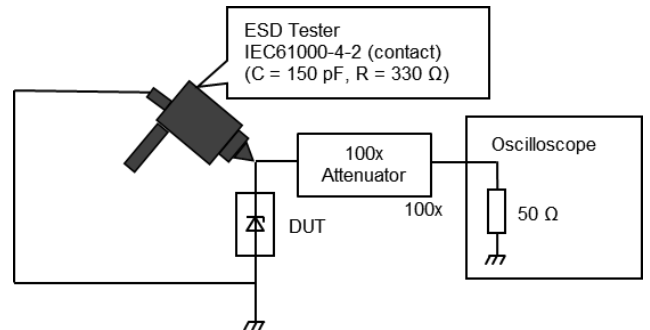

Based on IEC61000-4-2 (Contact)

Note 1: The above characteristics curves are presented for reference only and not guaranteed by production test, unless otherwise noted.

10.3. CSLZ6V2 Characteristics Curves (Note 1)

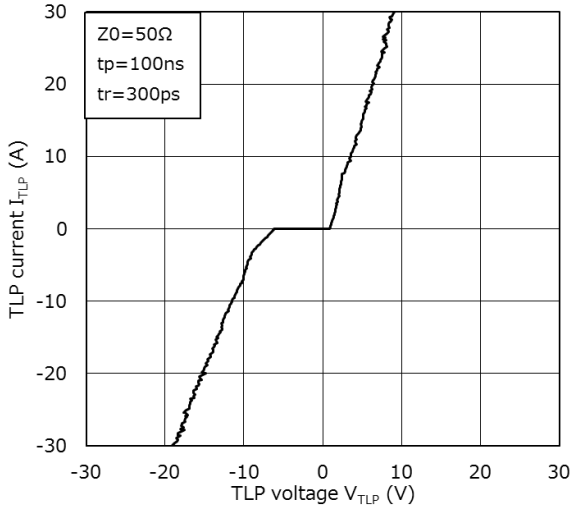

$I_{TLP} - V_{TLP}$

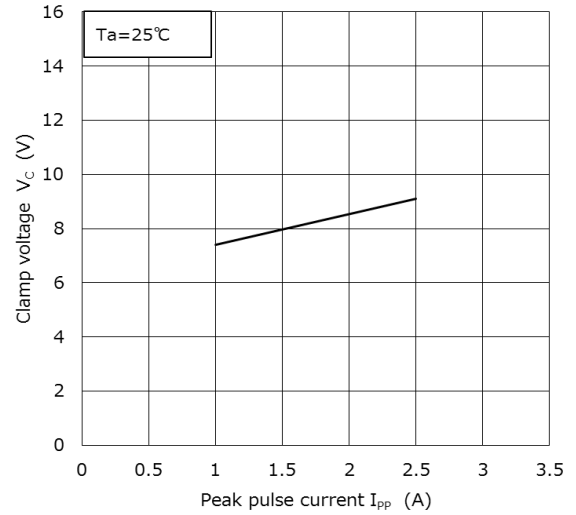

$V_C - I_{PP}$ (Note 2)

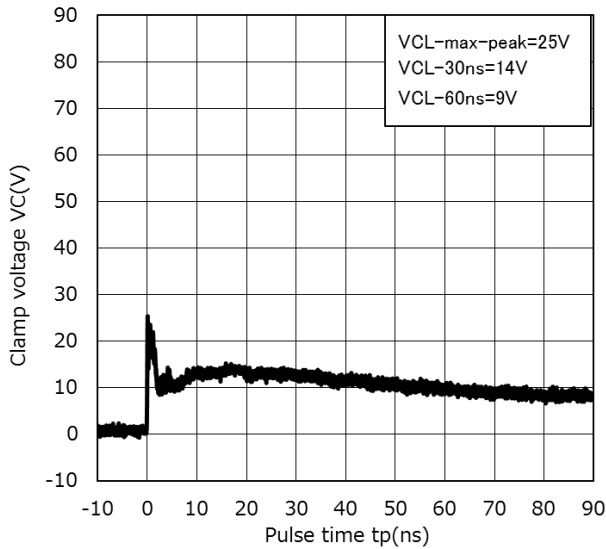

Clamp Waveform +8 kV (Note 3)

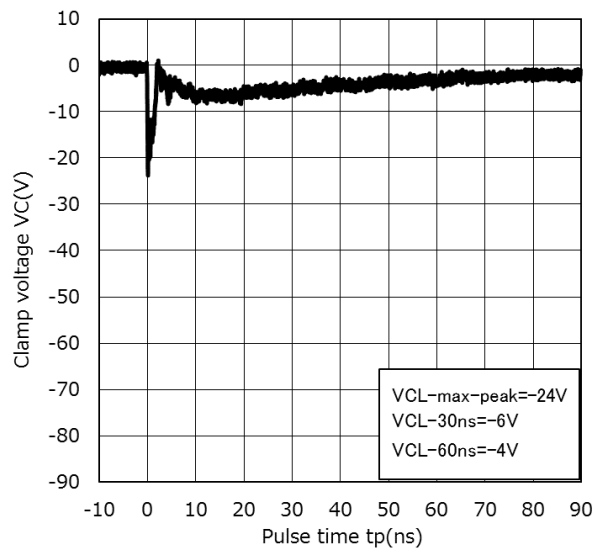

Clamp Waveform -8 kV (Note 3)

(Note 2) Peak Pulse Current ($V_C - I_{PP}$)

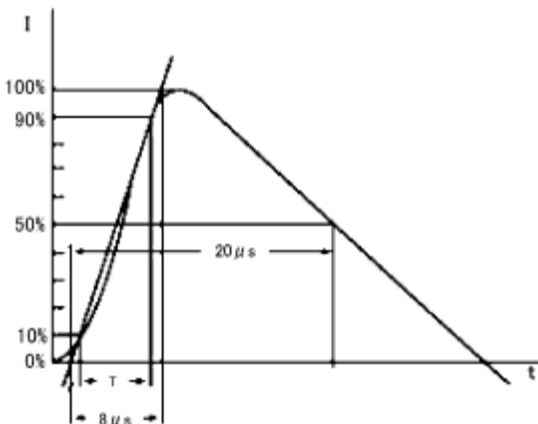

Based on IEC61000-4-5 8/20 μs pulse.

(Note 3) Clamp waveform measurement circuit

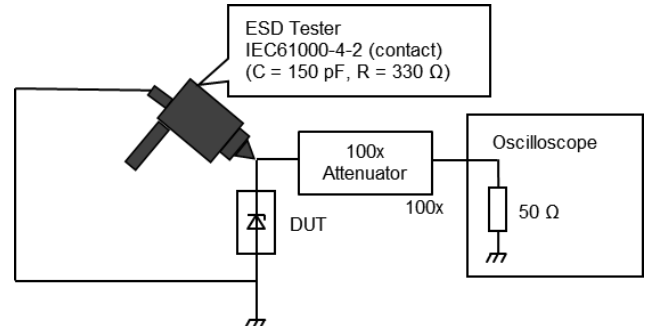

Based on IEC61000-4-2 (Contact)

Note 1: The above characteristics curves are presented for reference only and not guaranteed by production test, unless otherwise noted

10.4. CSLZ6V8 Characteristics Curves (Note 1)

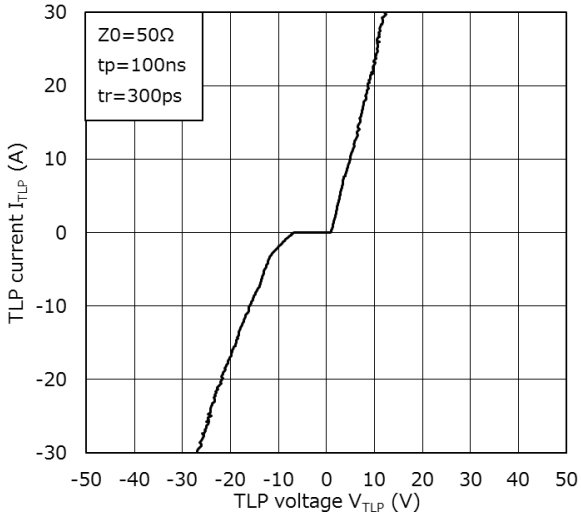

$I_{TLP} - V_{TLP}$

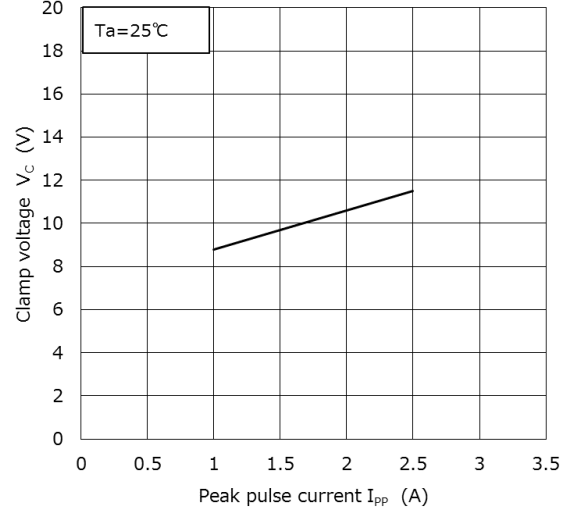

$V_C - I_{PP}$ (Note 2)

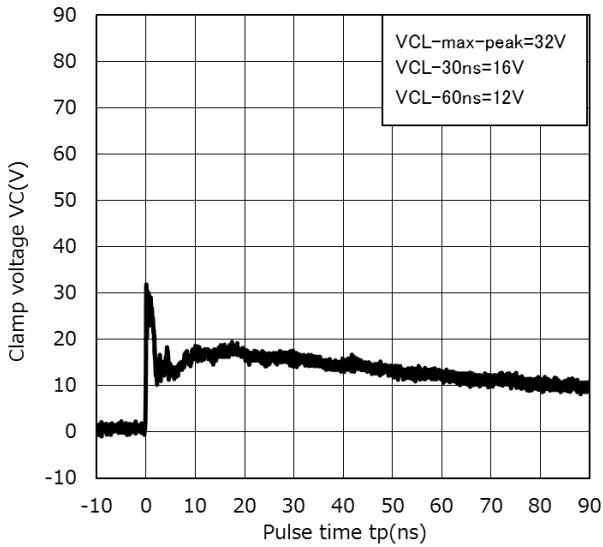

Clamp Waveform +8 kV (Note 3)

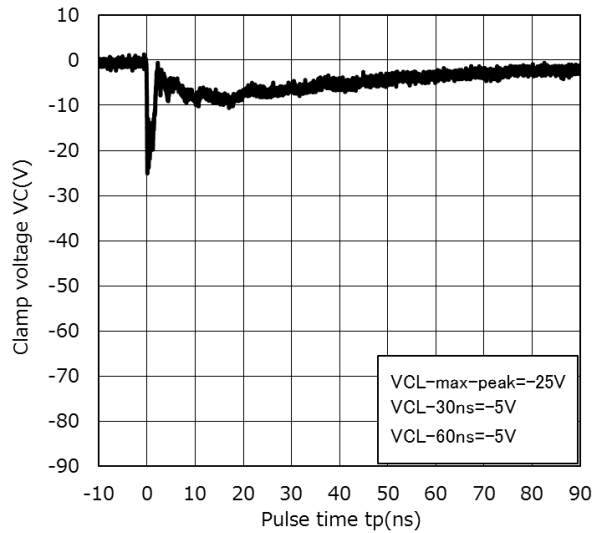

Clamp Waveform -8 kV (Note 3)

(Note 2) Peak Pulse Current ($V_C - I_{PP}$)

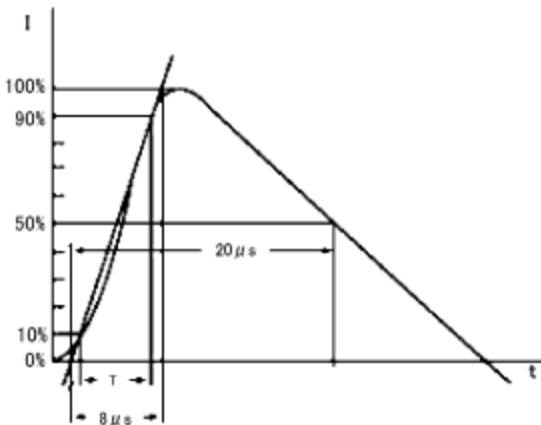

Based on IEC61000-4-5 8/20 μs pulse.

(Note 3) Clamp waveform measurement circuit

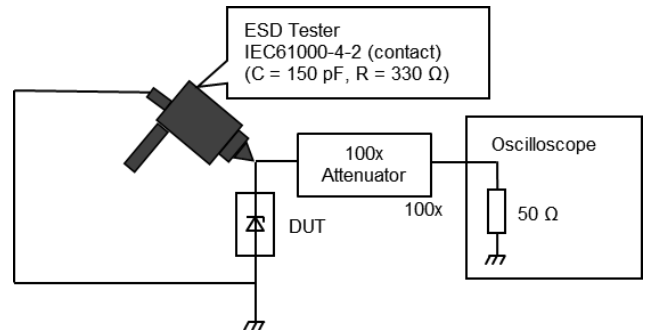

Based on IEC61000-4-2 (Contact)

Note 1: The above characteristics curves are presented for reference only and not guaranteed by production test, unless otherwise noted.

10.5. CSLZ8V2 Characteristics Curves (Note 1)

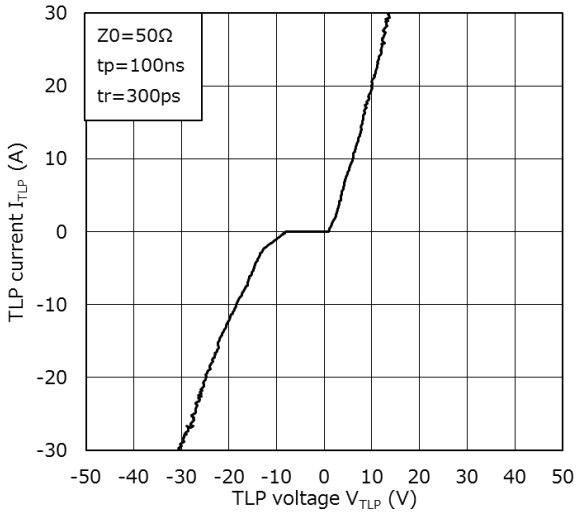

$I_{TLP} - V_{TLP}$

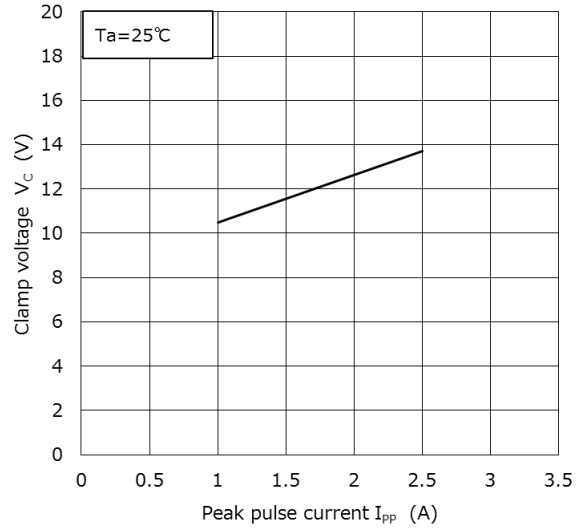

$V_C - I_{PP}$ (Note 2)

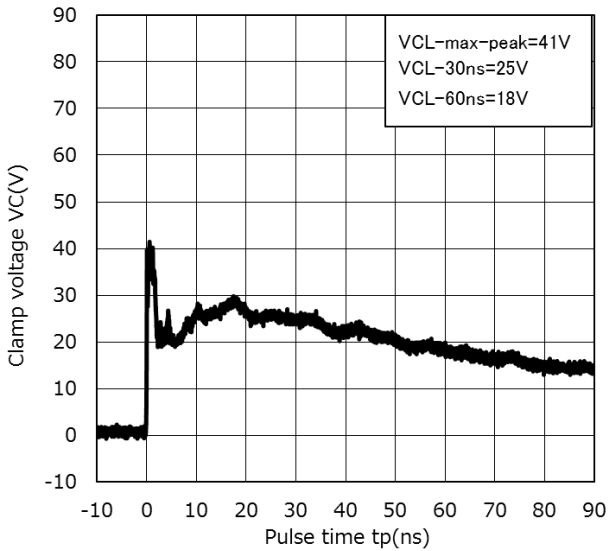

Clamp Waveform +8 kV (Note 3)

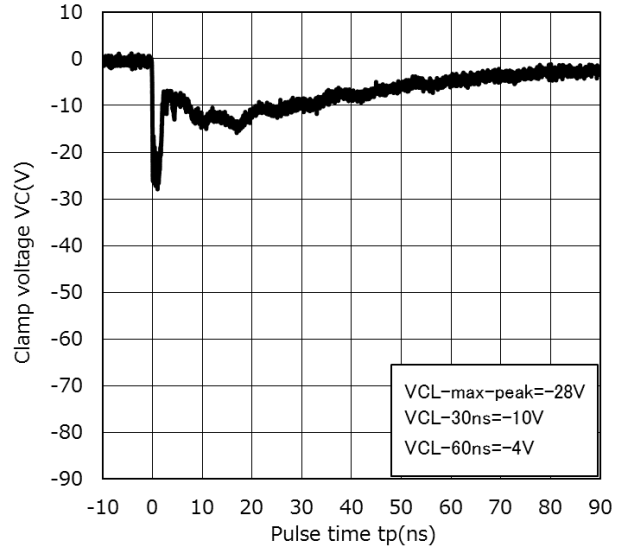

Clamp Waveform -8 kV (Note 3)

(Note 2) Peak Pulse Current ($V_C - I_{PP}$)

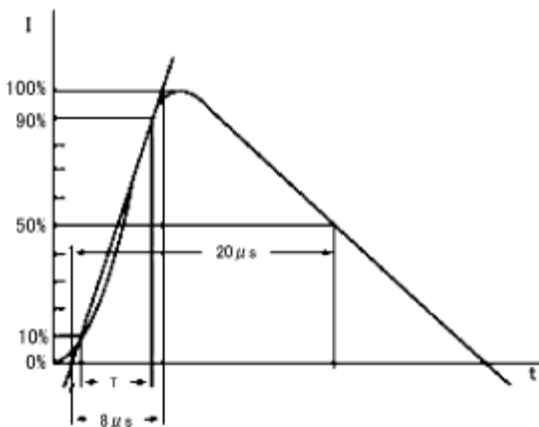

Based on IEC61000-4-5 8/20 μs pulse.

(Note 3) Clamp waveform measurement circuit

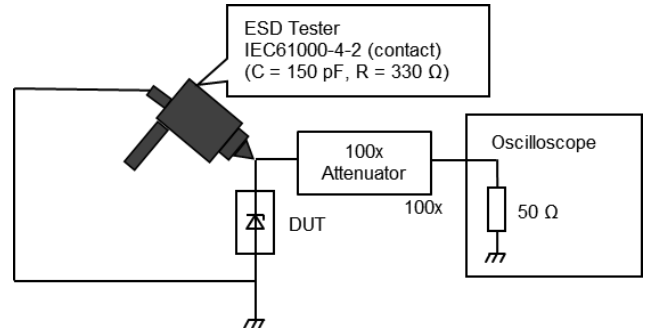

Based on IEC61000-4-2 (Contact)

Note 1: The above characteristics curves are presented for reference only and not guaranteed by production test, unless otherwise noted.

10.6. CSLZ10V Characteristics Curves (Note 1)

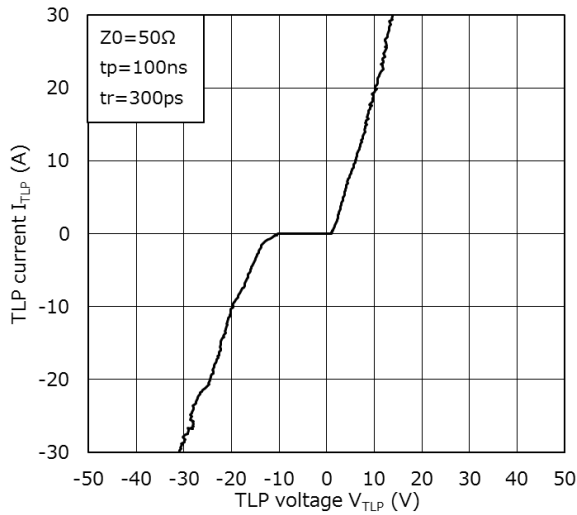

$I_{TLP} - V_{TLP}$

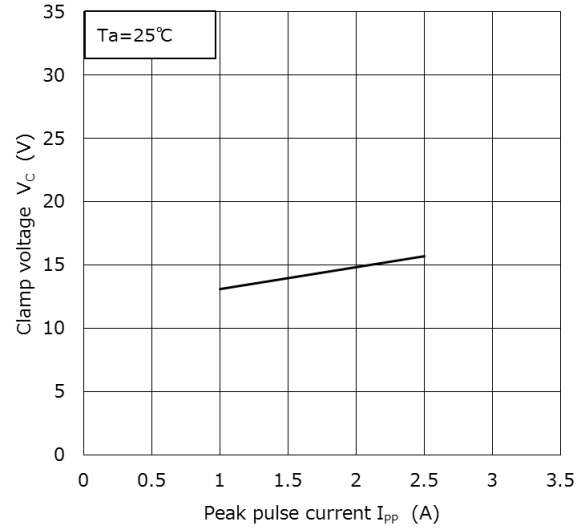

$V_C - I_{pp}$ (Note 2)

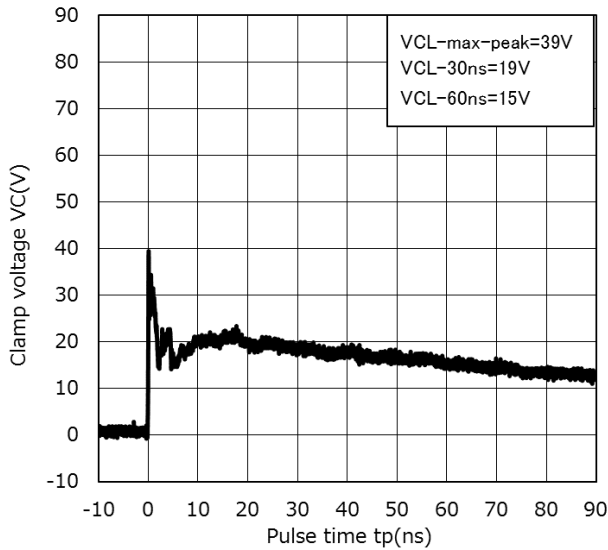

Clamp Waveform +8 kV (Note 3)

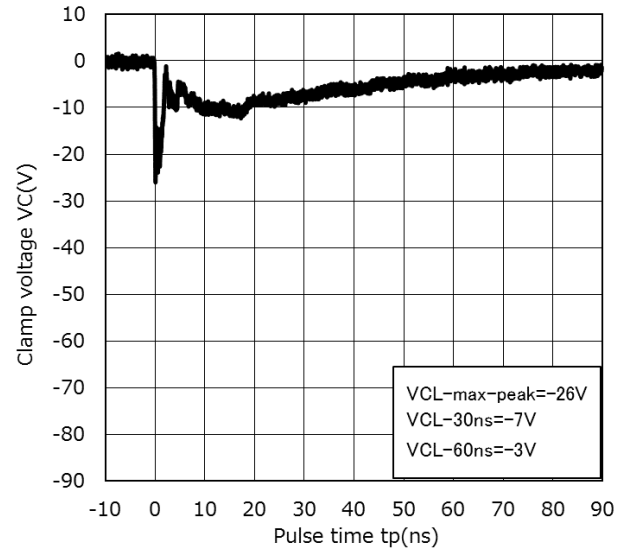

Clamp Waveform -8 kV (Note 3)

(Note 2) Peak Pulse Current ($V_C - I_{pp}$)

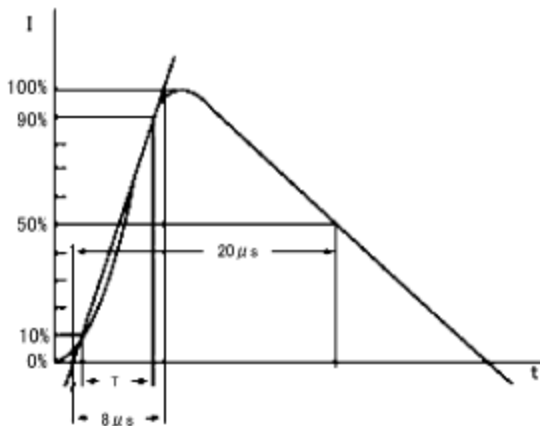

Based on IEC61000-4-5 8/20 μ s pulse.

(Note 3) Clamp waveform measurement circuit

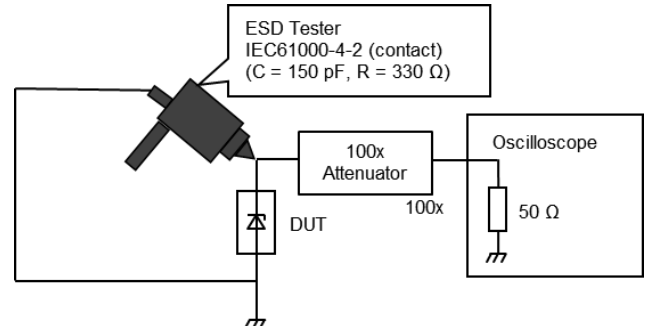

Based on IEC61000-4-2 (Contact)

Note 1: The above characteristics curves are presented for reference only and not guaranteed by production test, unless otherwise noted

10.7. CSLZ12V Characteristics Curves (Note 1)

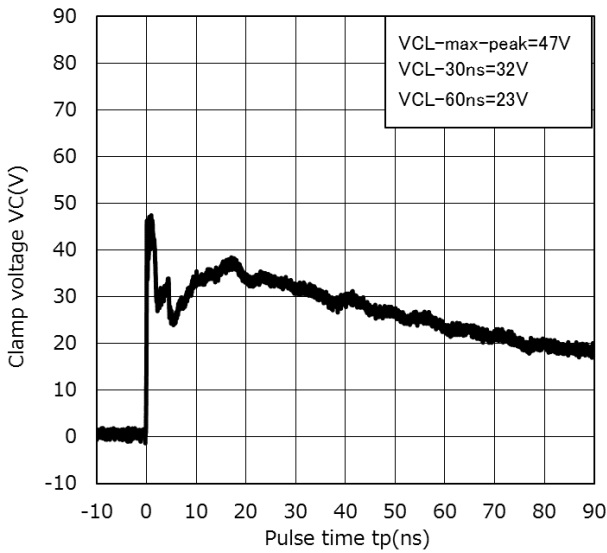
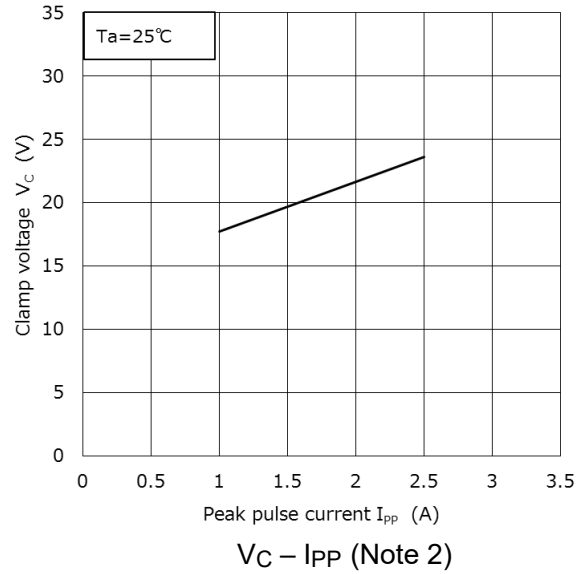
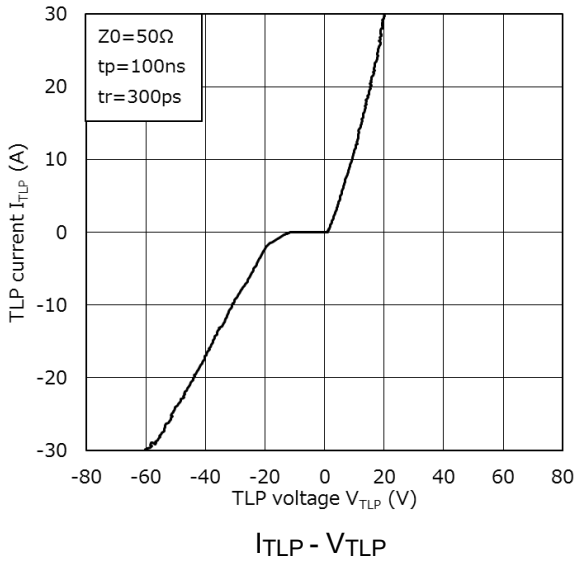

Clamp Waveform +8 kV (Note 3)

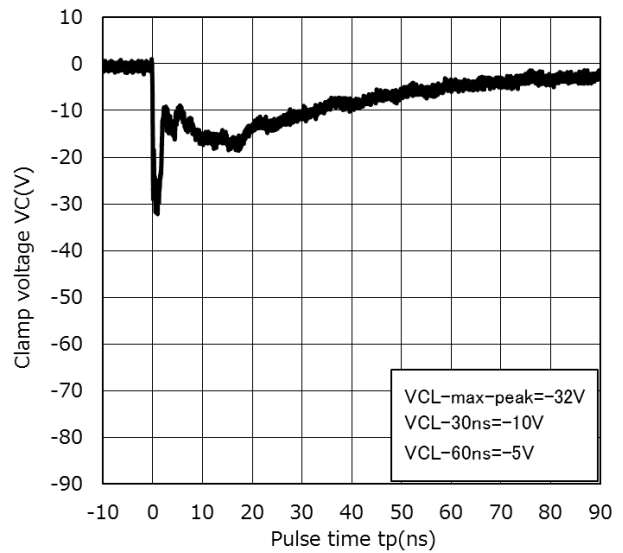

Clamp Waveform -8 kV (Note 3)

(Note 2) Peak Pulse Current ($V_C - I_{PP}$)

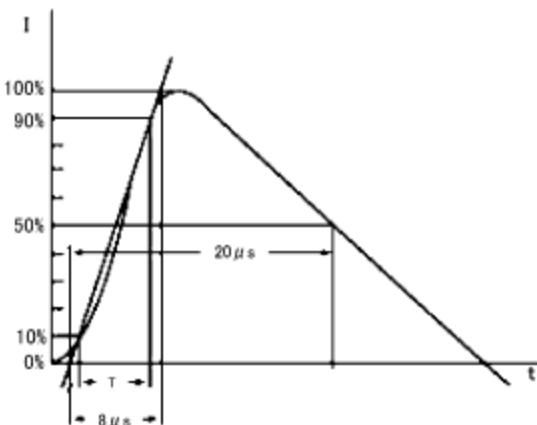

Based on IEC61000-4-5 8/20 μs pulse.

(Note 3) Clamp waveform measurement circuit

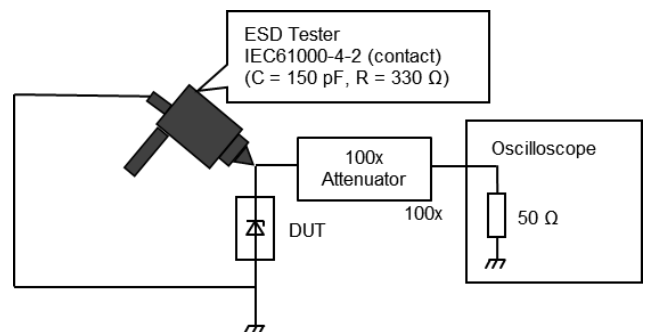

Based on IEC61000-4-2 (Contact)

Note 1: The above characteristics curves are presented for reference only and not guaranteed by production test, unless otherwise noted.

10.8. CSLZ16V Characteristics Curves (Note 1)

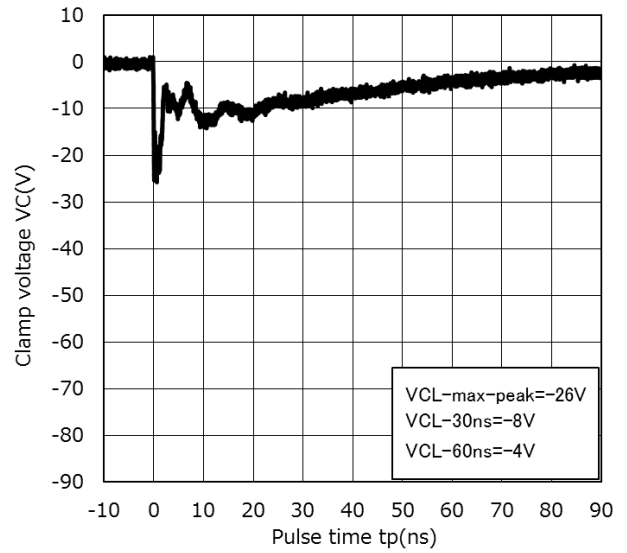
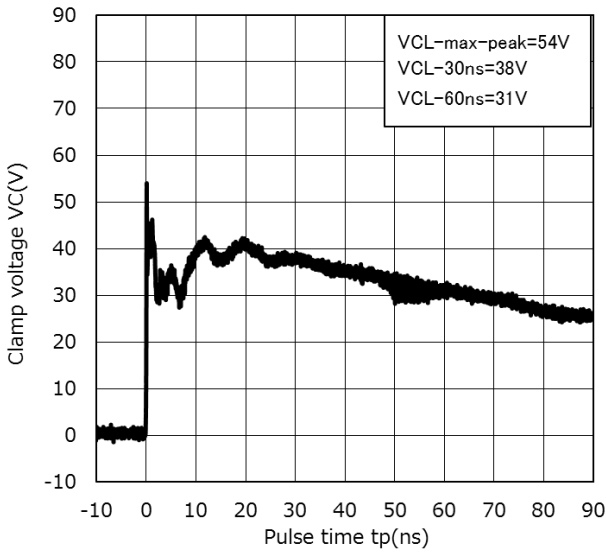
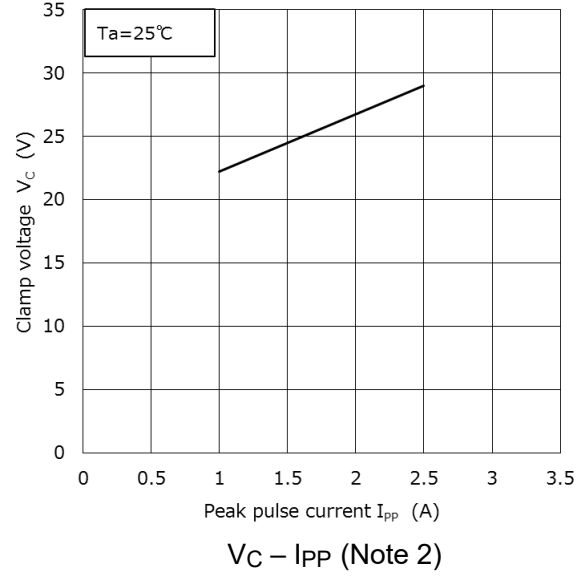
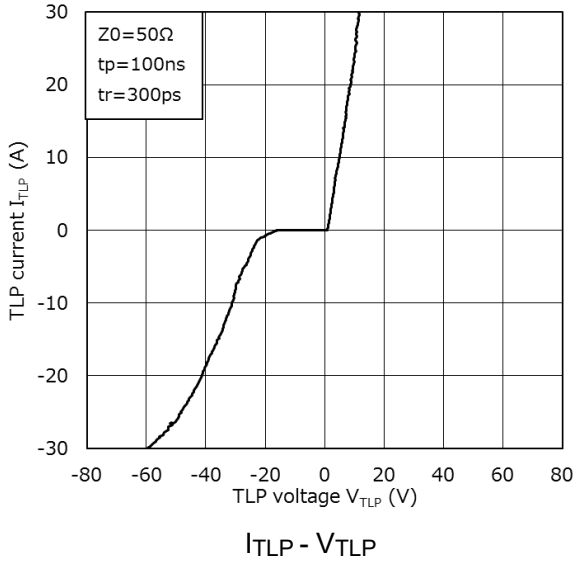

(Note 2) Peak Pulse Current ($V_C - I_{PP}$)

(Note 3) Clamp waveform measurement circuit

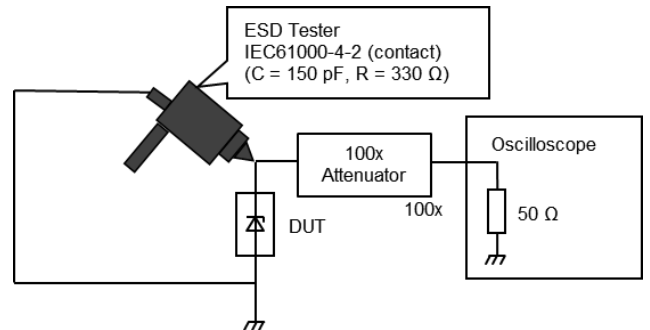
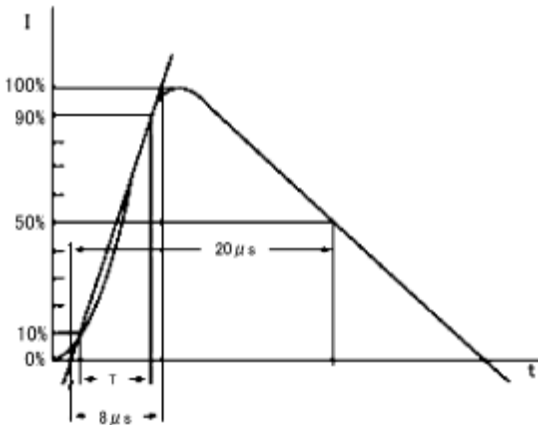

Based on IEC61000-4-2 (Contact)

Note 1: The above characteristics curves are presented for reference only and not guaranteed by production test, unless otherwise noted.

10.9. CSLZ20V Characteristics Curves (Note 1)

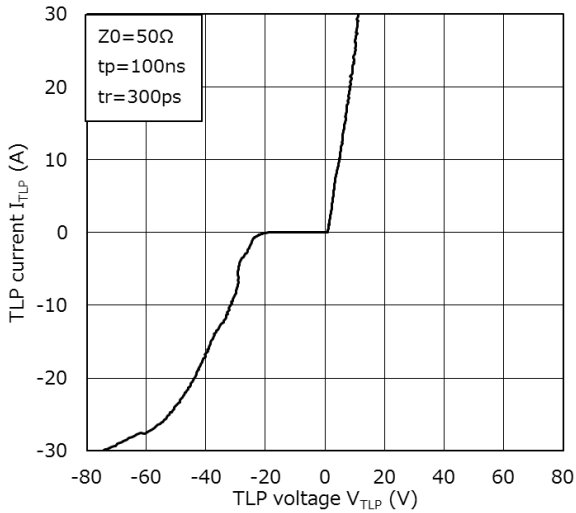

$I_{TLP} - V_{TLP}$

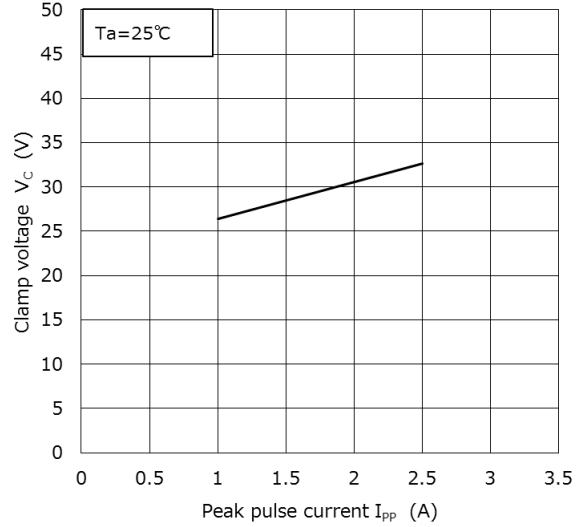

$V_C - I_{PP}$ (Note 2)

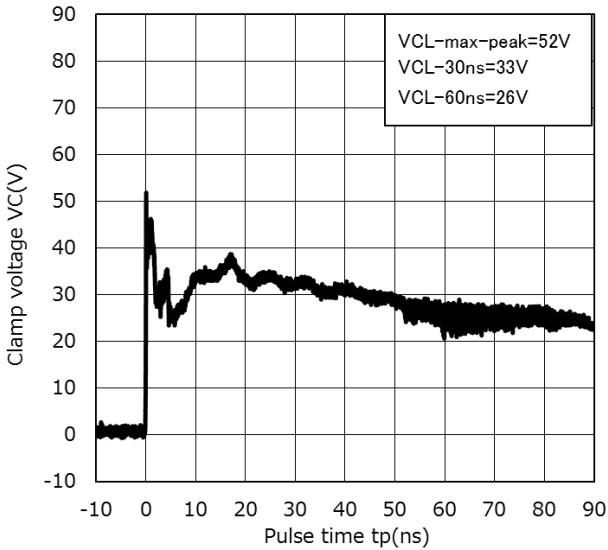

Clamp Waveform +8 kV (Note 3)

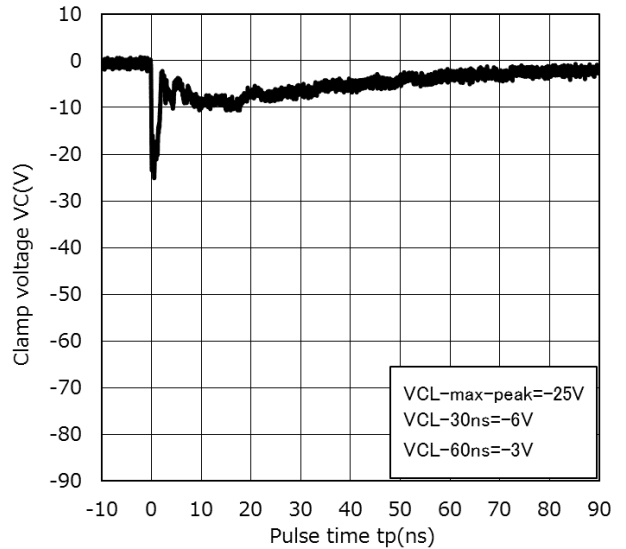

Clamp Waveform -8 kV (Note 3)

(Note 2) Peak Pulse Current ($V_C - I_{PP}$)

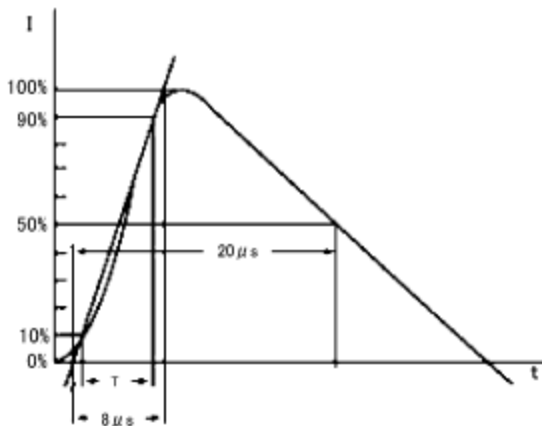

Based on IEC61000-4-5 8/20 μs pulse.

(Note 3) Clamp waveform measurement circuit

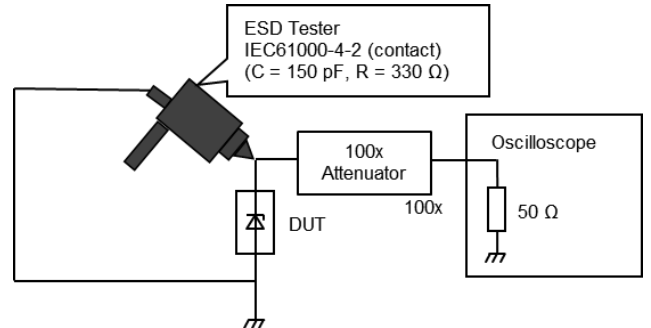

Based on IEC61000-4-2 (Contact)

Note 1: The above characteristics curves are presented for reference only and not guaranteed by production test, unless otherwise noted.

10.10. CSLZ24V Characteristics Curves (Note 1)

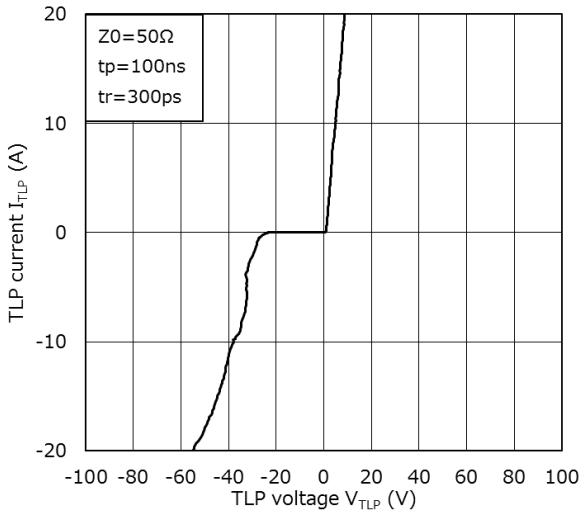

$I_{TLP} - V_{TLP}$

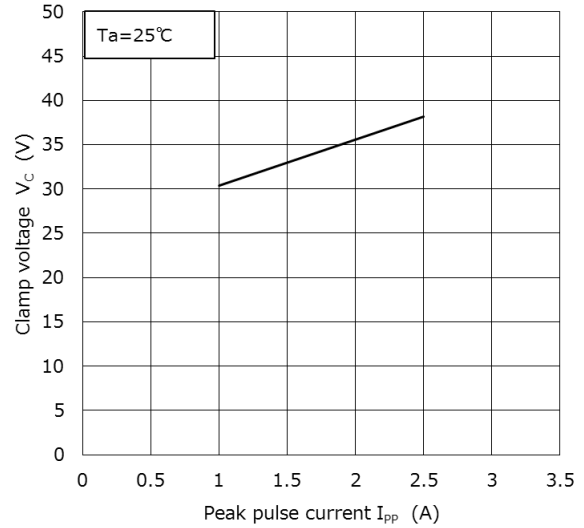

$V_C - I_{PP}$ (Note 2)

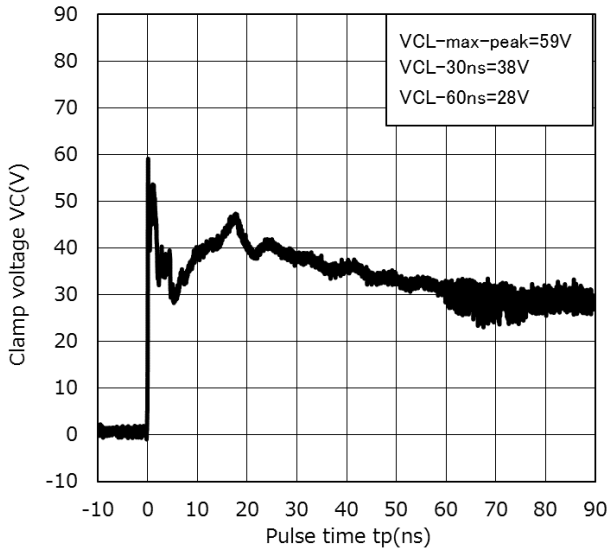

Clamp Waveform +8 kV (Note 3)

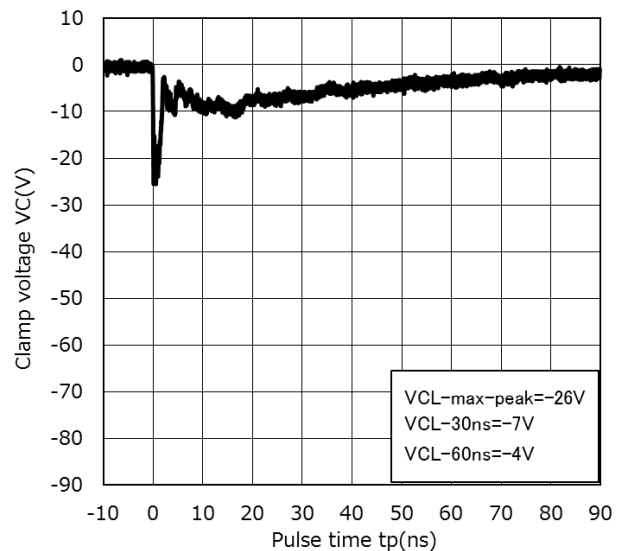

Clamp Waveform -8 kV (Note 3)

(Note 2) Peak Pulse Current ($V_C - I_{PP}$)

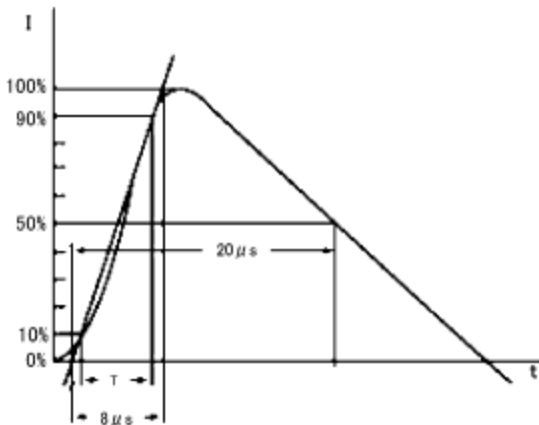

Based on IEC61000-4-5 8/20 μ s pulse.

(Note 3) Clamp waveform measurement circuit

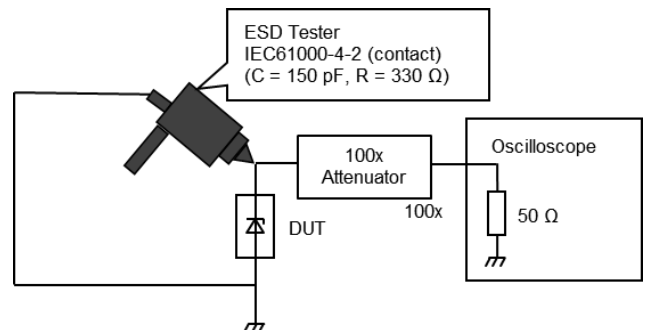

Based on IEC61000-4-2 (Contact)

Note 1: The above characteristics curves are presented for reference only and not guaranteed by production test, unless otherwise noted.

10.11. CSLZ30V Characteristics Curves (Note 1)

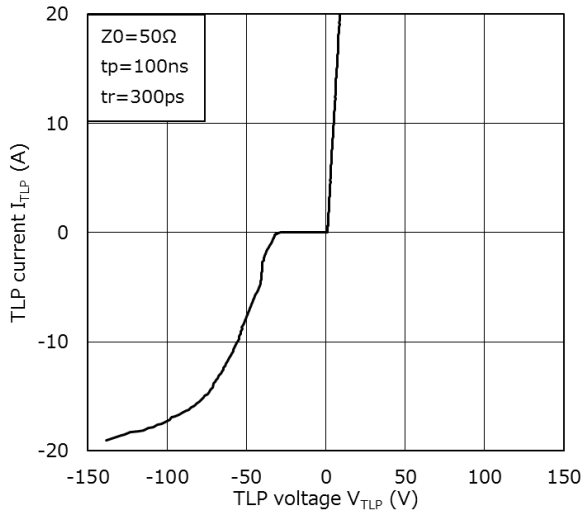

$I_{TLP} - V_{TLP}$

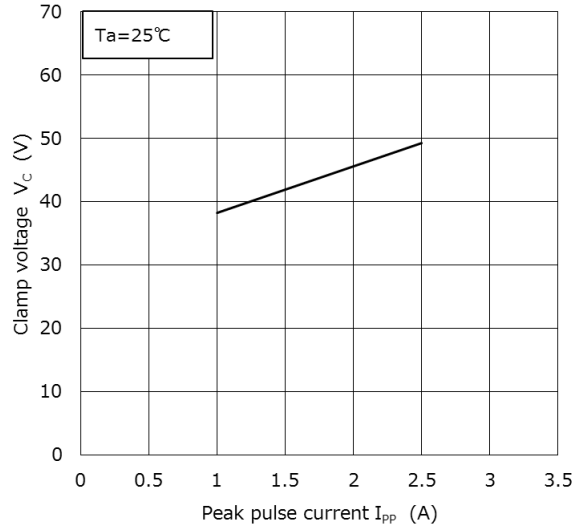

$V_C - I_{PP}$ (Note 2)

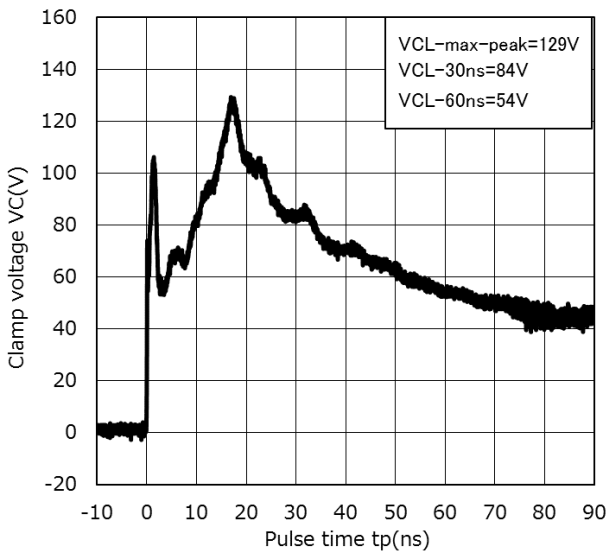

Clamp Waveform +8 kV (Note 3)

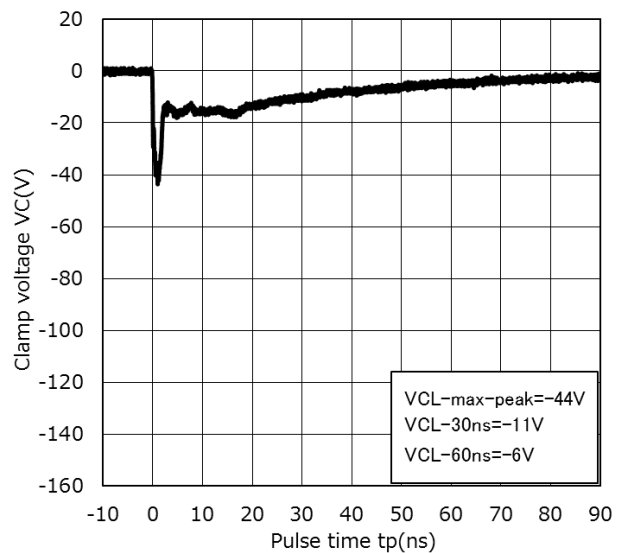

Clamp Waveform -8 kV (Note 3)

(Note 2) Waveform example ($V_C - I_{PP}$)

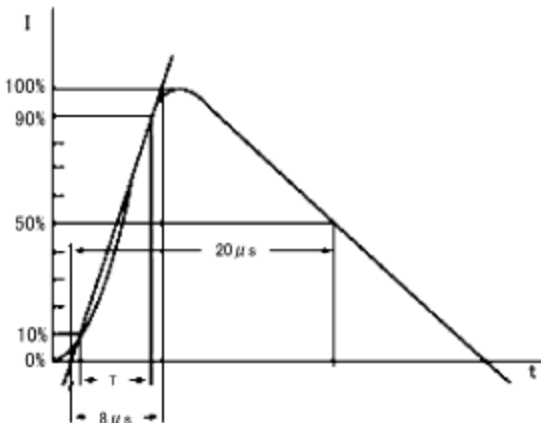

Based on IEC61000-4-5 8/20 μs pulse.

(Note 3) Clamp waveform measurement circuit

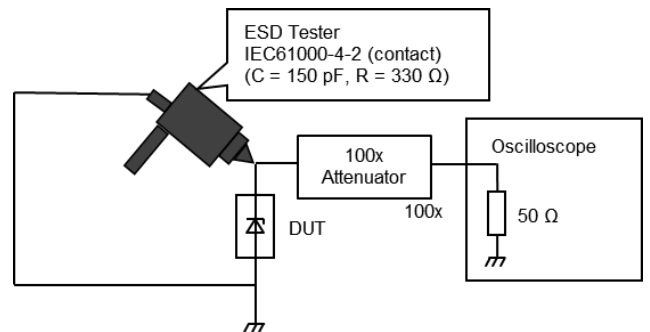

Based on IEC61000-4-2 (Contact)

Note 1: The above characteristics curves are presented for reference only and not guaranteed by production test, unless otherwise noted.

11. Package Dimensions

Unit: mm

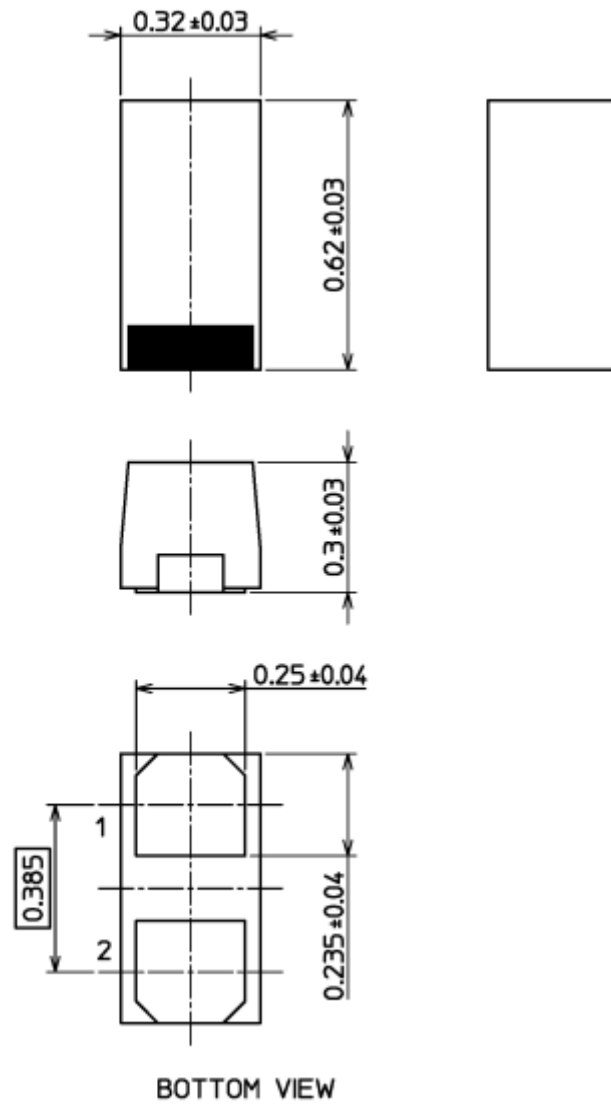

Weight: 0.2 mg (typ.)

RESTRICTIONS ON PRODUCT USE

Toshiba Corporation and its subsidiaries and affiliates are collectively referred to as "TOSHIBA". Hardware, software and systems described in this document are collectively referred to as "Product".

- TOSHIBA reserves the right to make changes to the information in this document and related Product without notice.
- This document and any information herein may not be reproduced without prior written permission from TOSHIBA. Even with TOSHIBA's written permission, reproduction is permissible only if reproduction is without alteration/omission.
- Though TOSHIBA works continually to improve Product's quality and reliability, Product can malfunction or fail. Customers are responsible for complying with safety standards and for providing adequate designs and safeguards for their hardware, software and systems which minimize risk and avoid situations in which a malfunction or failure of Product could cause loss of human life, bodily injury or damage to property, including data loss or corruption. Before customers use the Product, create designs including the Product, or incorporate the Product into their own applications, customers must also refer to and comply with (a) the latest versions of all relevant TOSHIBA information, including without limitation, this document, the specifications, the data sheets and application notes for Product and the precautions and conditions set forth in the "TOSHIBA Semiconductor Reliability Handbook" and (b) the instructions for the application with which the Product will be used with or for. Customers are solely responsible for all aspects of their own product design or applications, including but not limited to (a) determining the appropriateness of the use of this Product in such design or applications; (b) evaluating and determining the applicability of any information contained in this document, or in charts, diagrams, programs, algorithms, sample application circuits, or any other referenced documents; and (c) validating all operating parameters for such designs and applications. **TOSHIBA ASSUMES NO LIABILITY FOR CUSTOMERS' PRODUCT DESIGN OR APPLICATIONS.**
- **PRODUCT IS NEITHER INTENDED NOR WARRANTED FOR USE IN EQUIPMENTS OR SYSTEMS THAT REQUIRE EXTRAORDINARILY HIGH LEVELS OF QUALITY AND/OR RELIABILITY, AND/OR A MALFUNCTION OR FAILURE OF WHICH MAY CAUSE LOSS OF HUMAN LIFE, BODILY INJURY, SERIOUS PROPERTY DAMAGE AND/OR SERIOUS PUBLIC IMPACT ("UNINTENDED USE").** Except for specific applications as expressly stated in this document, Unintended Use includes, without limitation, equipment used in nuclear facilities, equipment used in the aerospace industry, Class 3 medical devices, equipment used for automobiles, and military vehicles and munitions. **IF YOU USE PRODUCT FOR UNINTENDED USE, TOSHIBA ASSUMES NO LIABILITY FOR PRODUCT.** For details, please contact your TOSHIBA sales representative or contact us via our website.
- Do not disassemble, analyze, reverse-engineer, alter, modify, translate or copy Product, whether in whole or in part.
- Product shall not be used for or incorporated into any products or systems whose manufacture, use, or sale is prohibited under any applicable laws or regulations.
- The information contained herein is presented only as guidance for Product use. No responsibility is assumed by TOSHIBA for any infringement of patents or any other intellectual property rights of third parties that may result from the use of Product. No license to any intellectual property right is granted by this document, whether express or implied, by estoppel or otherwise.
- **ABSENT A WRITTEN SIGNED AGREEMENT, EXCEPT AS PROVIDED IN THE RELEVANT TERMS AND CONDITIONS OF SALE FOR PRODUCT, AND TO THE MAXIMUM EXTENT ALLOWABLE BY LAW, TOSHIBA (1) ASSUMES NO LIABILITY WHATSOEVER, INCLUDING WITHOUT LIMITATION, INDIRECT, CONSEQUENTIAL, SPECIAL, OR INCIDENTAL DAMAGES OR LOSS, INCLUDING WITHOUT LIMITATION, LOSS OF PROFITS, LOSS OF OPPORTUNITIES, BUSINESS INTERRUPTION AND LOSS OF DATA, AND (2) DISCLAIMS ANY AND ALL EXPRESS OR IMPLIED WARRANTIES AND CONDITIONS RELATED TO SALE, USE OF PRODUCT, OR INFORMATION, INCLUDING WARRANTIES OR CONDITIONS OF MERCHANTABILITY, FITNESS FOR A PARTICULAR PURPOSE, ACCURACY OF INFORMATION, OR NONINFRINGEMENT.**
- Do not use or otherwise make available Product or related software or technology for any military purposes, including without limitation, for the design, development, use, stockpiling or manufacturing of nuclear, chemical, or biological weapons or missile technology products (mass destruction weapons). Product and related software and technology may be controlled under the applicable export laws and regulations including, without limitation, the Japanese Foreign Exchange and Foreign Trade Law and the U.S. Export Administration Regulations. Export and re-export of Product or related software or technology are strictly prohibited except in compliance with all applicable export laws and regulations.
- Please contact your TOSHIBA sales representative for details as to environmental matters such as the RoHS compatibility of Product. Please use Product in compliance with all applicable laws and regulations that regulate the inclusion or use of controlled substances, including without limitation, the EU RoHS Directive. **TOSHIBA ASSUMES NO LIABILITY FOR DAMAGES OR LOSSES OCCURRING AS A RESULT OF NONCOMPLIANCE WITH APPLICABLE LAWS AND REGULATIONS.**