

Notes in use of the TB67S539FTG

Overview

TB67S539FTG is a PWM chopper type 2-phase bipolar stepping motor driver with built-in a clock-in decoder. As excitation modes of 2-phase, 1-2 phase, W1-2 phase, 2W1-2 phase, 4W1-2 phase and 8W1-2 phase are selectable, motor can be easily controlled only by inputting the clock signal.

And owing to the function of Advanced Current Detect System (ACDS), PWM constant current drive without external current detection resistor is realized.

※ The contents described in the application note are reference for evaluating the product. Therefore, the contents described cannot be guaranteed. As for the detailed materials, please check the data sheet.

Contents

Overview	1
1. Power supply voltage	4
1.1. Operating range of Power supply voltage	4
1.2. Sequence of power supply	4
2. Output current	4
3. Control input	4
3.1. Function description	5
3.1.1. SLEEP_X function	5
3.1.2. CLK function	5
3.1.3. ENABLE function	5
3.1.4. CW/CCW function	6
3.1.5. DMODE0, DMODE1, and DMODE2 function	6
3.1.6. Selectable Mixed Decay function	7
3.1.7. ADMD (Advanced Dynamic Mixed Decay) function	8
3.1.8. RESET function	9
3.1.9. TRQ function	9
3.1.10. MO function	10
3.1.11. LO (error detection flag output) function	10
4. Constant current control	11
4.1. The calculation formula of current value setting	11
4.2. Correction of output setting current	11
4.3. OSCM Oscillation Frequency and Chopping Frequency	12
4.4. Constant current waveform when the chopping frequency is changed	13
5. Fault detection circuit	14
6. Power consumption of the device	15
7. Application circuit example	16
7.1. Capacitor for power supply pins	17
7.2. Wiring pattern for power supply / GND	17
7.3. Hughes	17
8. PCBA design dimensions for reference	18
Note on Contents	19
IC Usage Considerations	19
RESTRICTIONS ON PRODUCT USE	21

Figures

Figure 1.1 VM operating range and UVLO threshold	4
Figure 3.1 SLEEP_X Timing	5
Figure 3.2 Mixed Decay Timing	7
Figure 3.3 ADMD timing chart	8
Figure 3.4 ADMD timing chart (Blanking period)	8
Figure 4.1 VREF offset table	11
Figure 4.2 Constant current waveform (when $f_{\text{CHOP}} = 100 \text{ kHz}$)	13
Figure 4.3 Constant current waveform (when $f_{\text{CHOP}} = 50 \text{ kHz}$)	13
Figure 5.1 TSD operation	14
Figure 5.2 ISD operation	14
Figure 7.1 Application circuit example	16
Figure 8.1 PCBA design dimensions for reference	18

Tables

Table 3.1 SLEEP_X functions	5
Table 3.2 CLK function	5
Table 3.3 ENABLE function	5
Table 3.4 CW/CCW function	6
Table 3.5 DMODE0, DMODE1, and DMODE2 function	6
Table 3.6 Selectable Mixed Decay function	7
Table 3.7 RESET function	9
Table 3.8 Initial electrical angle after reset of electrical angle	9
Table 3.9 TRQ function	9
Table 3.10 MO function	10
Table 3.11 LO function	10
Table 4.1 VREF correction factor	11
Table 7.1 Recommended values of capacitor at power supply pins	17

1. Power supply voltage

1.1. Operating range of Power supply voltage

In use of the TB67S539FTG, voltage supply to the VM pin and the VREF pin is required. Even though the absolute maximum rating of the VM power supply voltage is 35V (in active), please use within the operating range: 4.5 to 34V. The slew rate at power on should be used 0.05 V/ μ s or less as a guideline.

The VREF pin should be used within the operating range: 0 to 3.6 V.

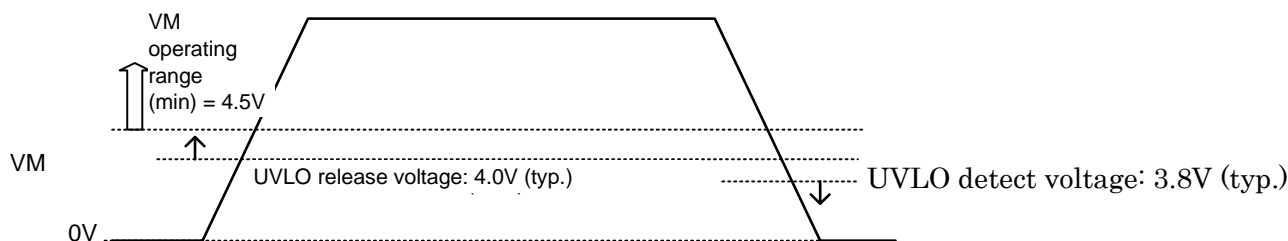

Figure 1.1 VM operating range and UVLO threshold

1.2. Sequence of power supply

Owing to the built-in regulator a single power supply drive is realized in this device. And owing to the built-in low power supply voltage detection (UVLO) malfunctions at low power supply voltage can be prevented.

When the voltage of VM is unstable at turning power on / off (transient area), it is recommended to turn off the motor operation. Please start motor operation by switching the input signal after the power supply voltage becomes stable. And likewise, it is recommended to turn off the power supply after the motor has stopped completely.

2. Output current

Please use this device within the operating range of the motor current: 1.8A or less (per phase). And the maximum current value that can be used actually is limited by application conditions (ambient environment temperature, the board wiring, heat dissipation path, etc.). Please set the optimum current value within the range that does not exceed the allowable loss under operating environment after thermal calculation and actual evaluation.

3. Control input

This device is configured that no electromotive force by the signal input is generated, even though the logic input signal is input during the VM voltage is not supplied. However, it is recommended to set the input signal low level before the power supply is turned on. As the logic input signal is specified as $V_{IN(H)} = 2.0V$ (min.) and $V_{IN(L)} = 0.8V$ (max.), this device can be also controlled with input signal of the 3.3V system. Pull-down resistors of 100 k Ω (typ.) are integrated.

3.1. Function description

3.1.1. SLEEP_X function

SLEEP_X is a function to switch the power saving mode and the normal operation mode. By setting the sleep mode once and then setting the normal operation mode again, it is possible to recover from the output forced OFF state caused by the operation of the overheat detection circuit (TSD) / over-current detection circuit (ISD). By setting SLEEP_X = Low, the power saving mode is set after 100 μs. After inputting SLEEP_X=High, the device returns to normal operation in 10 ms (max.).

Table 3.1 SLEEP_X functions

SLEEP_X	Function
L	Power saving mode (charge pump stopped, VCC Reg stopped)
H	Normal operation mode

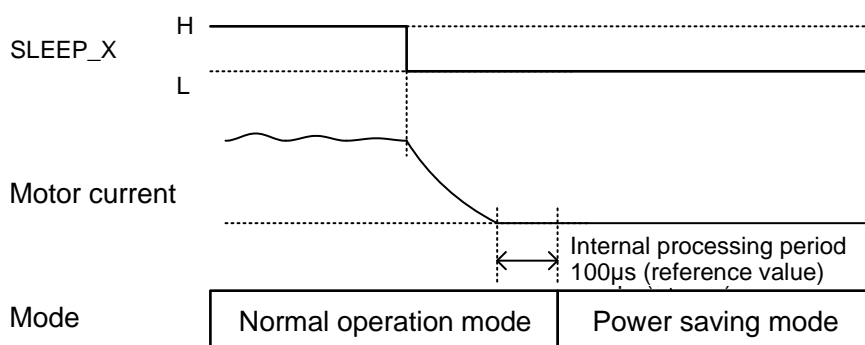

Figure 3.1 SLEEP_X Timing

(Note) Please control the SLEEP_X pin from a logic signal such as the MCU. In particular, when pull - up to a power supply such as 5V or 3.3V through a resistor, please adjust the rise time of the signal to less than 0.1ms.

3.1.2. CLK function

CLK is a function to advance electrical angle. Each CLK advances the electrical angle by one. The signal is captured at the Up edge.

Table 3.2 CLK function

CLK	Function
↑	Shift to the next step at the Up edge
↓	(Maintain the previous state)

3.1.3. ENABLE function

ENABLE is a function to switch the stepping motor drive ON / OFF. When the motor drive is turned ON, normal constant current control is started, and when it is set OFF, the MOSFETs are turned off and the outputs are high impedance.

Table 3.3 ENABLE function

ENABLE	Function
H	Output MOSFET operation: ON (normal operation)

ENABLE	Function
L	Output MOSFET operation: OFF (operation stopped, high impedance)

3.1.4. CW/CCW function

CW / CCW is a function to switch the rotation direction of the stepping motor.

Table 3.4 CW/CCW function

CW/CCW	Function
H	Forward rotation (CW)
L	Reverse rotation (CCW)

3.1.5. DMODE0, DMODE1, and DMODE2 function

DMODE is a function to switch the step resolution. Switching excitation modes even while driving a motor is supported. After inputting DMODE data, the modes are switched at the Up edge of the next external CLK. After switching modes, it is shifted to the nearest electric angle in the direction of rotation.

Table 3.5 DMODE0, DMODE1, and DMODE2 function

DMODE0	DMODE1	DMODE2	Function
L	L	L	Full step resolution setting
L	L	H	Half step resolution (a) setting
L	H	L	Half step resolution (b) setting
L	H	H	Quarter step resolution setting
H	L	L	1/8 step resolution setting
H	L	H	1/16 step resolution setting
H	H	L	1/32 step resolution setting
H	H	H	1/32 step resolution setting

3.1.6. Selectable Mixed Decay function

Selectable Mixed Decay is a function that can adjust the amount of current recirculation during the current recirculation (Decay) period by those pins.

The Mixed Decay control itself is realized by switching the three controls of Charge, Slow, and Fast. By the DECAY pins, the constant current control can be selected from the four settings. When this setting is switched during the constant current detection operation, the setting after switching is reflected from the next chopping cycle.

Table 3.6 Selectable Mixed Decay function

DECAY2 pin	DECAY1 pin	Function
L	L	Mixed Decay
L	H	Slow Decay only
H	L	Fast Decay only
H	H	ADMD

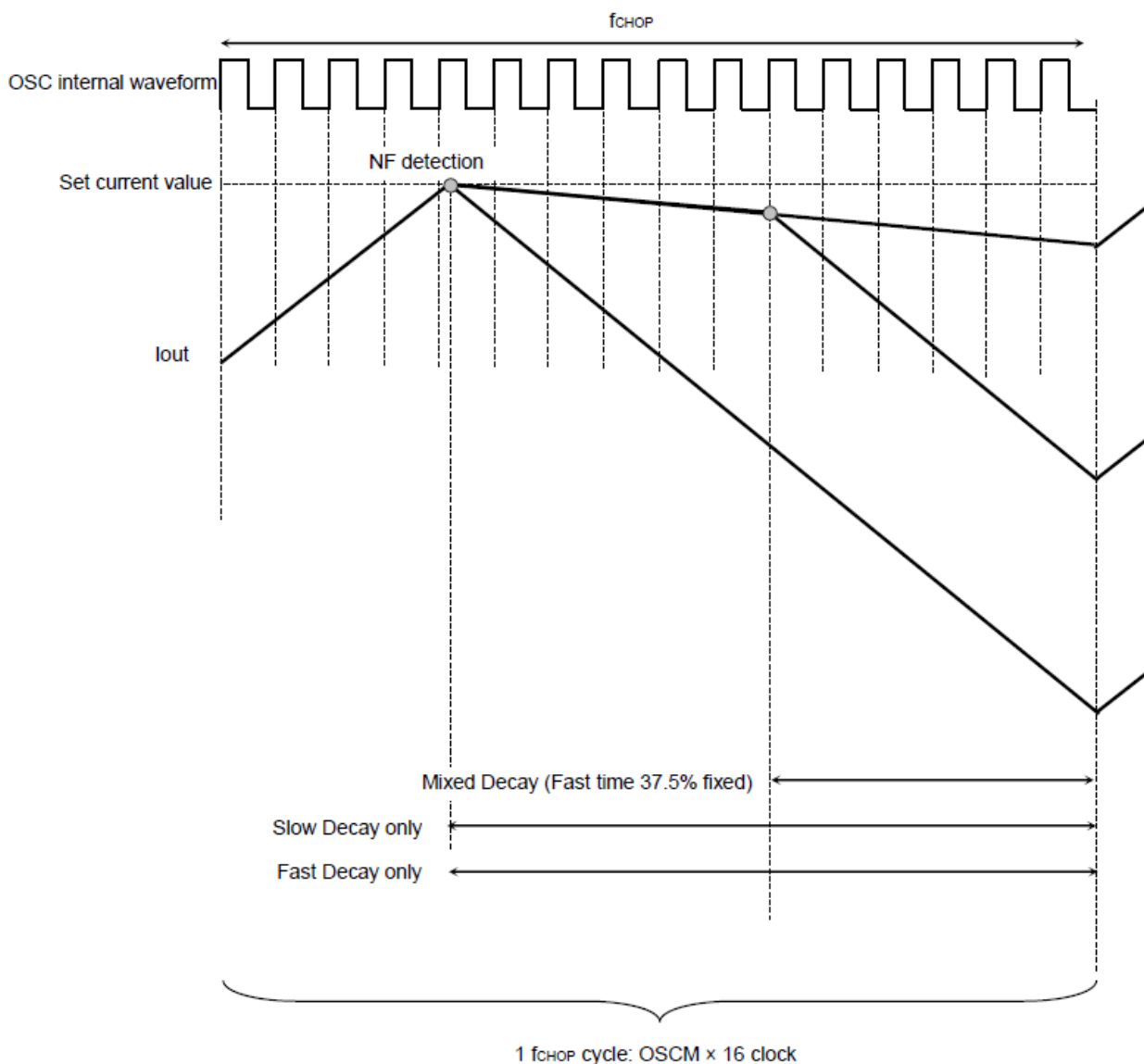

Figure 3.2 Mixed Decay Timing

Note: The timing chart is partially omitted or simplified to explain functions and operation.

3.1.7. ADMD (Advanced Dynamic Mixed Decay) function

ADMD is a function that both the current flowing from the power supply to the motor and the current recirculated from the motor to the power supply are monitored, and a constant current PWM control is performed. The basic sequence of ADMD is as follows.

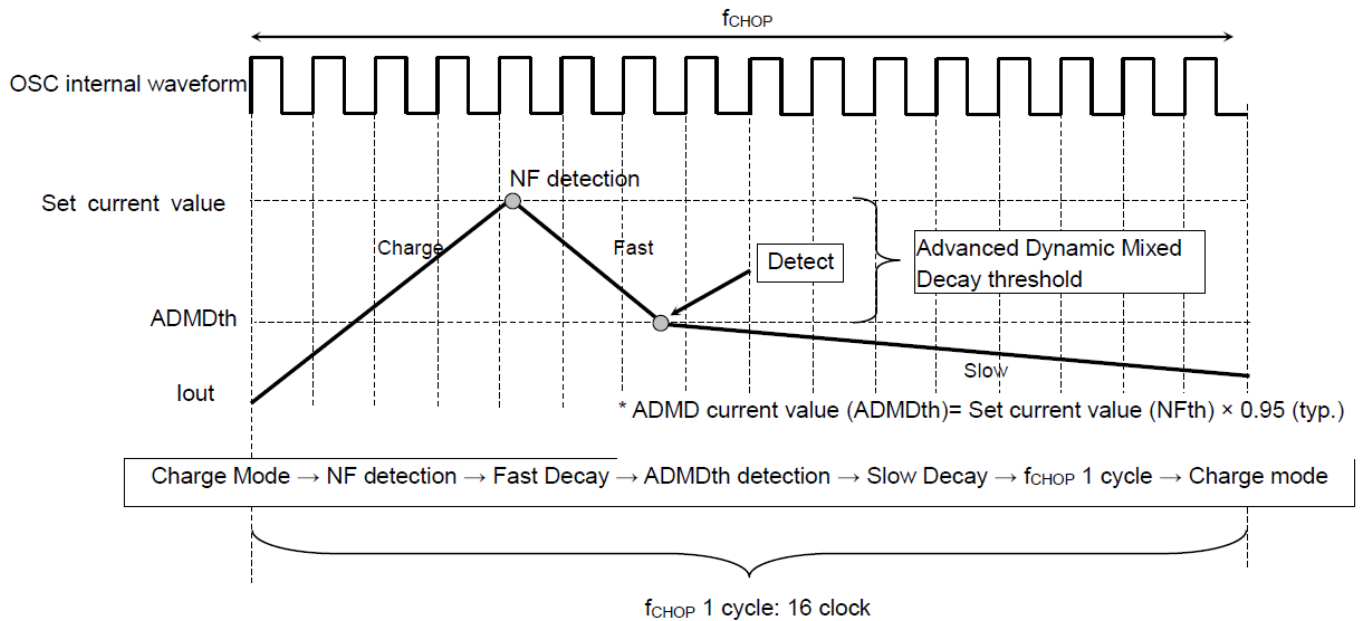

Figure 3.3 ADMD timing chart

Note: The timing chart is partially omitted or simplified to explain functions and operation. The values in the timing chart are reference ones.

As shown below various filters are provided to prevent false current detection caused by noise from outside and etc..

If the L value of the motor in use is small and the current value reaches ADMDth (ADMD current value) within the ADMDtblank period, the operation switches to Slow operation after the ADMDtblank period elapses. In this case, the ADMD current value (ADMDth) is smaller than the setting current value (NFth) x 0.95 (typ.).

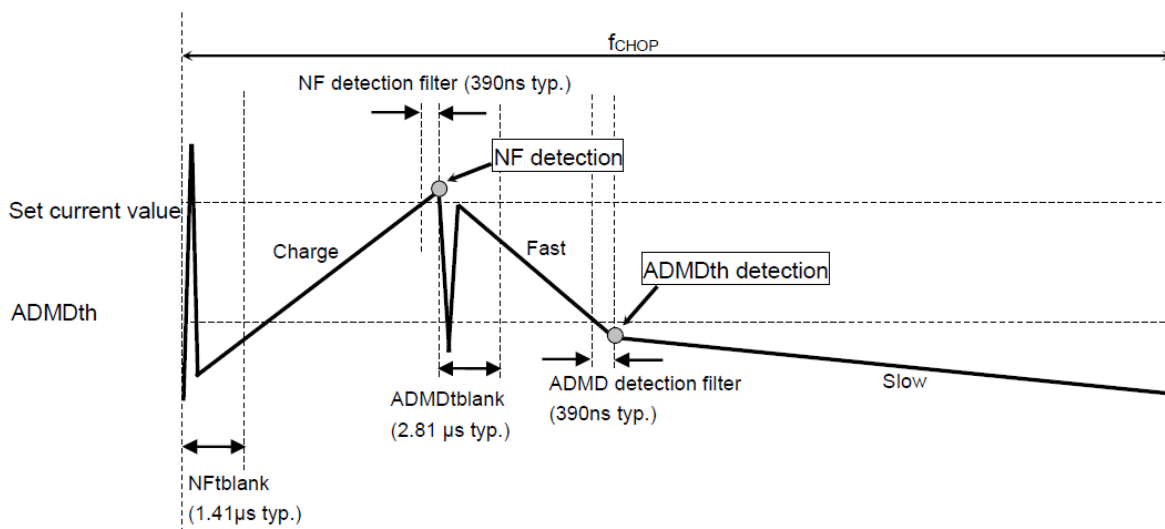

Figure 3.4 ADMD timing chart (Blanking period)

Note: The timing chart is partially omitted or simplified to explain functions and operation. The values in the timing chart are reference ones.

3.1.8. RESET function

RESET is a function to initialize the internal electrical angle.

Table 3.7 RESET function

RESET	Function
H	Electrical angle initialization
L	Normal operation

The currents of each phase when the RESET pin is set high are as follows.

Table 3.8 Initial electrical angle after reset of electrical angle

Excitation mode	A-phase current	B-phase current	Initial electrical angle
Full step resolution setting	100%	100%	45°
Half step resolution (a) setting	100%	100%	45°
Half step resolution (b) setting	71%	71%	45°
Quarter step resolution setting	71%	71%	45°
1/8 step resolution setting	71%	71%	45°
1/16 step resolution setting	71%	71%	45°
1/32 step resolution setting	71%	71%	45°

3.1.9. TRQ function

TRQ is a function to set the torque of a motor.

Table 3.9 TRQ function

TRQ1 pin input	TRQ0 pin input	Function
L	L	Torque setting: 100%
L	H	Torque setting: 75%
H	L	Torque setting: 50%
H	H	Torque setting: 25%

3.1.10. MO function

MO is a function to confirm the internal electric angle. Please connect the output of the MO pin to the potential of 3.3V or 5V with a pull-up resistor of 10 k to 100 kΩ.

Table 3.10 MO function

MO	Function
H (Pull-up)	Other than the initial electrical angle
L	The initial electrical angle

3.1.11. LO (error detection flag output) function

LO is a function to output a signal to the outside when the error detection functions start operation. In use of this function, as the LO1 pin and the LO2 pin are an open drain type those outputs should be connected to the potential of 3.3V or 5V with a pull-up resistor of 10 k to 100 kΩ respectively.

In normal operation, the output level of the LO1 pin is Hi-Z (internal MOSFETs are OFF). When error detection function (over-temperature (TSD) or over-current (ISD)) starts operation, the output level of the pin is Low (internal MOSFETs are ON).

When the VM power supply is turned on again or error detections are canceled by the sleep mode, the LO pin is returned to "the normal state (normal operation)" again. In case of no use of the LO pins, please leave those pins open. And the LO2 pin is Low only when TSD is detected.

Table 3.11 LO function

LO1 pin output	Function
H (Pull-up)	Normal status (Normal operation)
L	Status of over-current (ISD) or over-temperature (TSD) detected

LO2 pin output	Function
H (Pull-up)	Normal status (Normal operation)
L	Status of over-temperature (TSD) detected

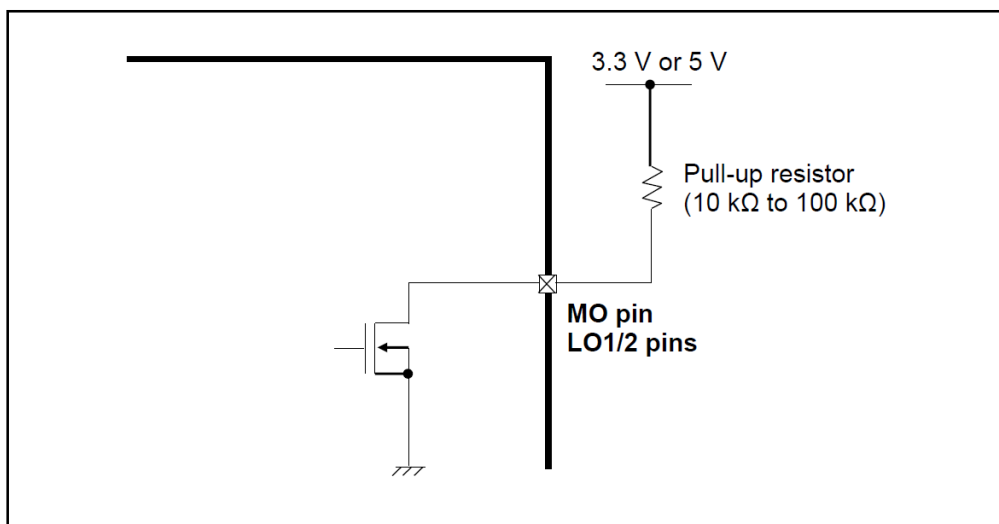

The equivalent circuit may be partially omitted or simplified to explain the circuit.

* Notes in using the LO pins

As a system of this device, the internal regulator is stopped for power saving when SLEEP_X = L. When SLEEP_X = H, the internal regulator is started up, but since there is an internal undefined period before rise up, the internal Logic block is initialized again for stable operation. Therefore, LO1 is Low for a moment at start-up. When the LO1 is monitored all the time, please mask the signal for 100μs (max) at switching SLEEP_X from Low to High. In addition, as the LO2 is also used as a Toshiba internal test pin, it is an input / output configuration pin. Therefore, when this pin is pulled up to an external 5V while the VM power supply is not turned on, a current inflow occurs. but it is not affected to the operation of this device.

4. Constant current control

4.1. The calculation formula of current value setting

In the TB67S539FTG the constant current value is set only by the input voltage value of the VREF pin without using an external current detection resistor. Setting current value: Iout (max) is calculated by the following formula.

$$I_{out} (\text{max}) = 0.556 \times V_{ref} (\text{V})$$

4.2. Correction of output setting current

In use of this device under conditions other than IOUT = 1.0A, an error caused by the circuit off-set can be reduced by using the correction coefficient.

$$(I_{OUT}/0.556) \times \text{correction coefficient} = V_{REF}$$

Table 4.1 VREF correction factor

IOUT(A)	Correction factor
0.13	0.77
0.23	0.88
0.32	0.93
0.42	0.95
0.52	0.96
0.62	0.97
0.71	0.98
0.81	0.99
0.91	0.99
1	1

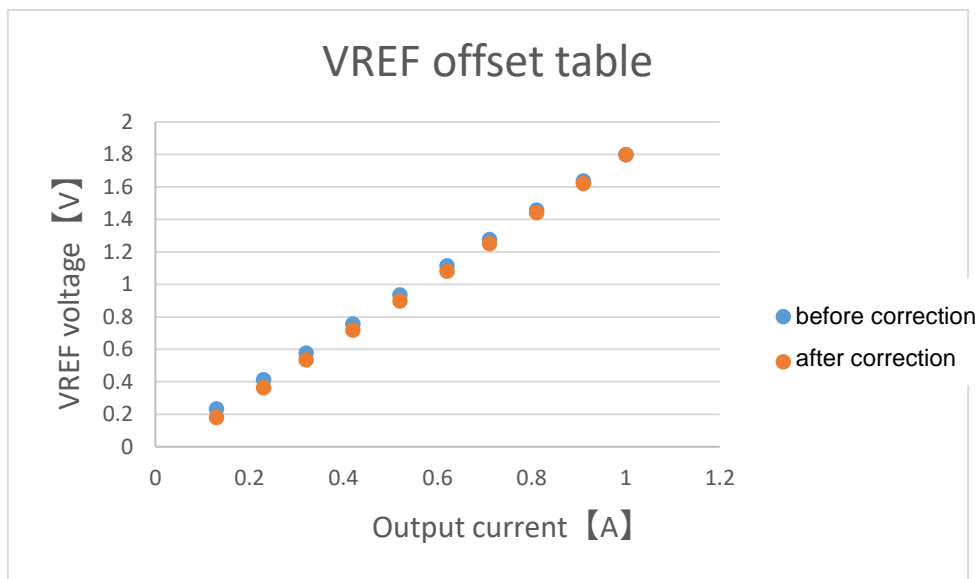
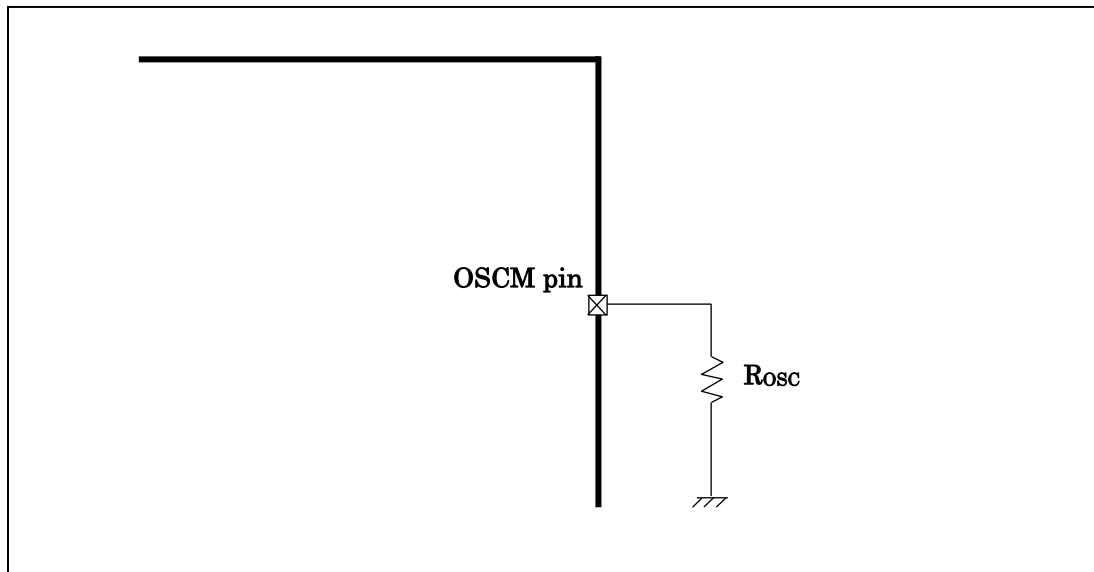

Figure 4.1 VREF offset table

Note: The graph above is not a guaranteed value, but a reference one.

4.3. OSCM Oscillation Frequency and Chopping Frequency

In the TB67S539FTG the internal oscillation frequency (f_{OSCM}) and the accompanying chopping frequency (f_{CHOP}) can be adjusted by the constant of an external resistor (R_{OSC}) connected to the OSCM pin. And it is also possible to use with a fixed chopping frequency without connecting external parts to the OSCM pin.



The equivalent circuit may be partially omitted or simplified to explain the circuit.

The chopping frequency (f_{CHOP}) can be calculated by the following formula. In general, it is recommended to consider approximately 70 kHz as a typical value and set the frequency within the range of 40 kHz to 100 kHz.

$$f_{\text{CHOP}} = f_{\text{OSCM}} / 16$$

$$f_{\text{OSCM}} = 1 / (\alpha \times R_{\text{OSC}} + \beta) \text{ [MHz]} * \alpha = 1.7 \times 10^{-5}, \beta = 0.0285$$

Example: When $R_{\text{OSC}} = 47 \text{ k}\Omega$, $f_{\text{OSCM}} = 1.2 \text{ MHz (typ.)}$, $f_{\text{CHOP}} = 75 \text{ kHz (typ.)}$

When the OSCM pin is open or shorted to the GND, the TB67S539FTG operates with the frequencies that $f_{\text{OSCM2}} = 914 \text{ kHz (typ.)}$ and $f_{\text{CHOP}} = 57.1 \text{ kHz (typ.)}$ which are generated inside the device automatically.

When the chopping frequency is increased, the waveform reproducibility is improved because the current ripple is reduced, but on the other hand the heat generation is increased because the gate loss inside the device is increased. To the contrary the chopping frequency is lowered, a decrease in heat generation can be expected, but the current ripple may increase.

4.4. Constant current waveform when the chopping frequency is changed.

It is generally recommended to set and use a chopping frequency (f_{CHOP}) of approximately 70 kHz as a typical value. And when the chopping frequency is increased from the typical one, the ripple of a motor current can be reduced and the waveform quality is improved. But on the other hand, as the number of chopping is increased, switching loss also increases and heat generation increases. When the waveform quality is prioritized, increase the chopping frequency, and when the heat generation is concerned, decrease the chopping frequency.

Example 1: When chopping frequency (f_{CHOP}) = 100 kHz

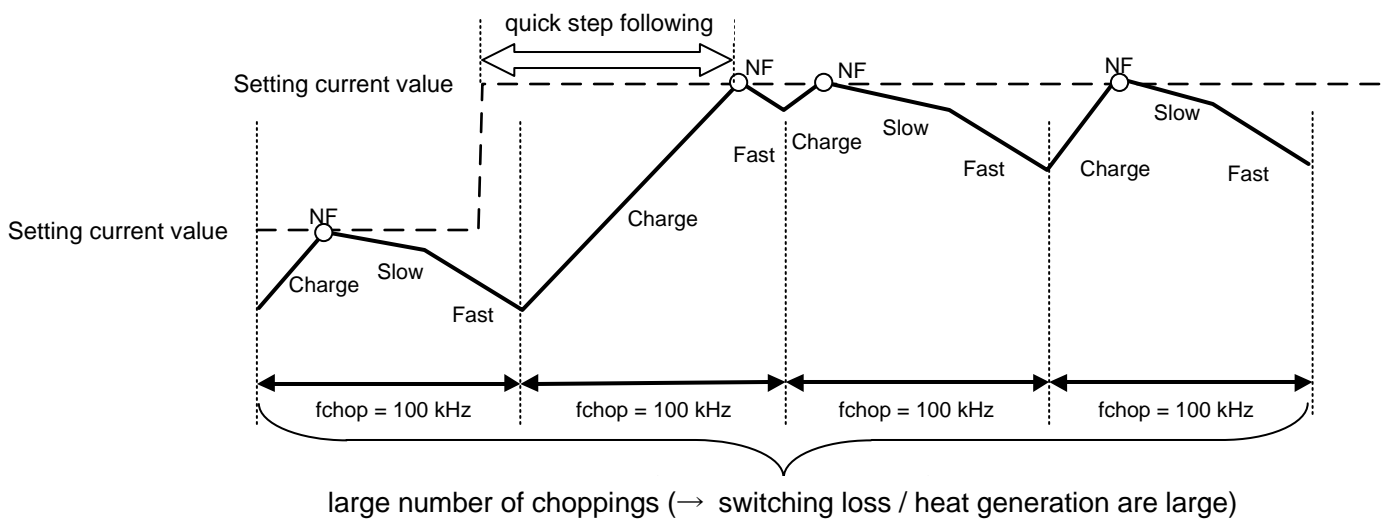

Figure 4.2 Constant current waveform (when $f_{CHOP} = 100$ kHz)

Example 2: When chopping frequency (f_{CHOP}) = 50kHz

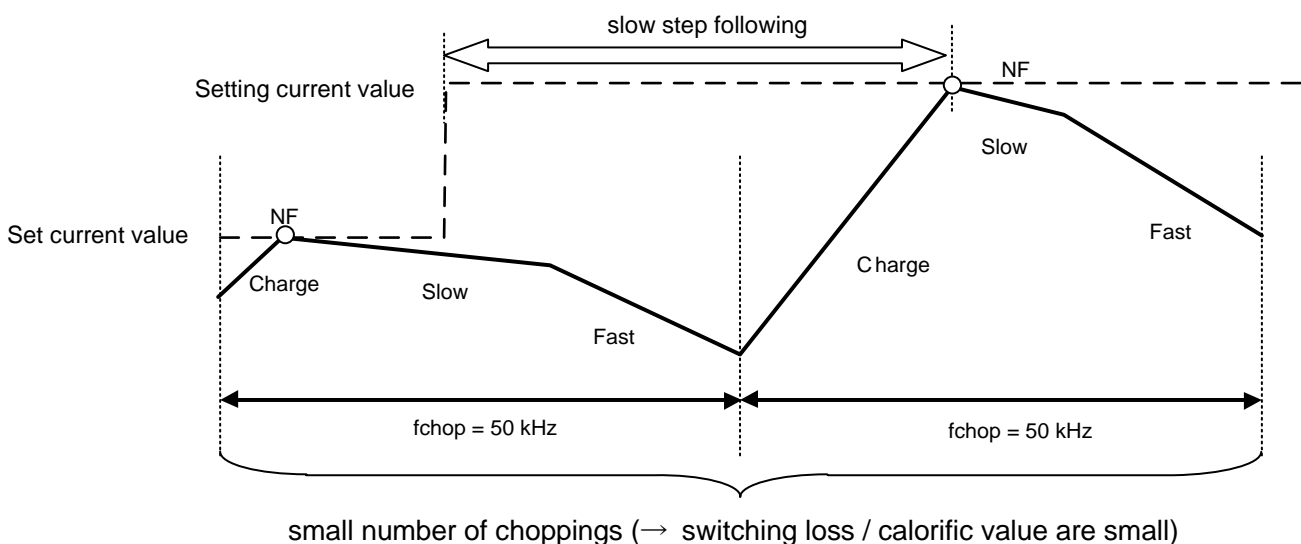

Figure 4.3 Constant current waveform (when $f_{CHOP} = 50$ kHz)

5. Fault detection circuit

Over-temperature detection circuit (TSD)

When the junction temperature of the device reaches 160 °C (typ.), the internal detection circuit starts operation and latches the output section to OFF state. A dead band time of 5 μs (typ.) is provided internally to avoid false detection caused by noise from the outside. After the TSD operation, it can be canceled by turning the power on again or setting the standby mode. As the TSD is a function that detects when the device overheats abnormally, please avoid utilizing this function aggressively.

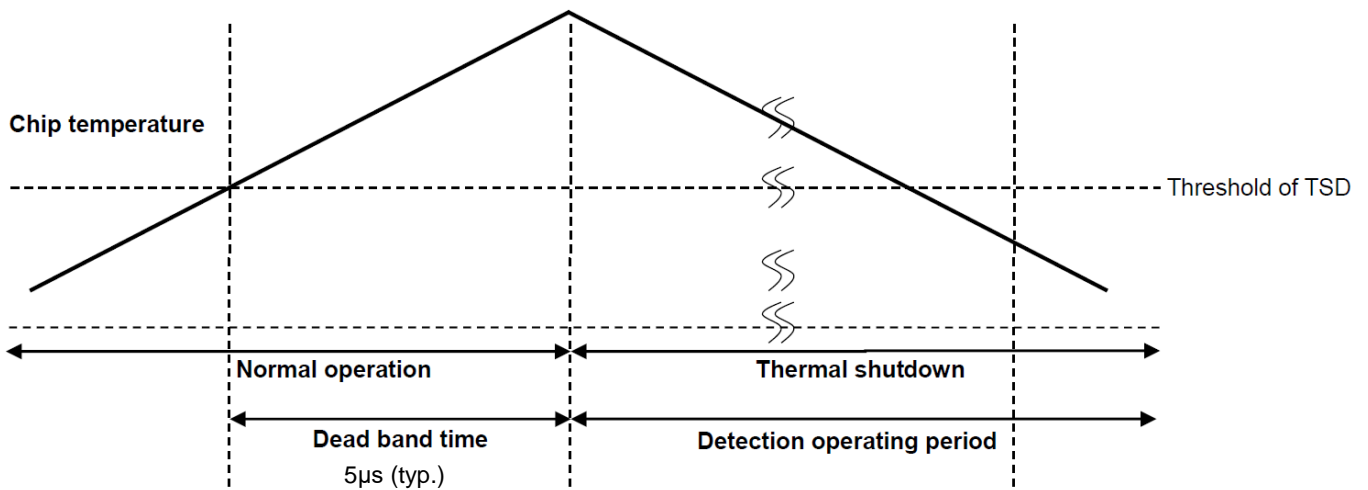

Figure 5.1 TSD operation

Note: The above time widths are not a guaranteed value, but a reference value.

Low voltage detection circuit (UVLO)

When the voltage applied to the VM pin reaches 3.8 V (typ.) or less, the internal detection circuit starts operation and puts the output section off state. After the UVLO operation, it is canceled by setting the voltage applied to the VM pin to 4.0V (typ.) or higher.

Over-current detection circuit (ISD)

When a current exceeding the specified value flows through the motor output, the internal detection circuit starts operation and latches the output section to OFF state. A dead zone period of 1.25 μs (typ.) is provided internally to avoid malfunctions caused by switching or ets.. After the ISD operation, it can be canceled by turning the power on again or setting the standby mode.

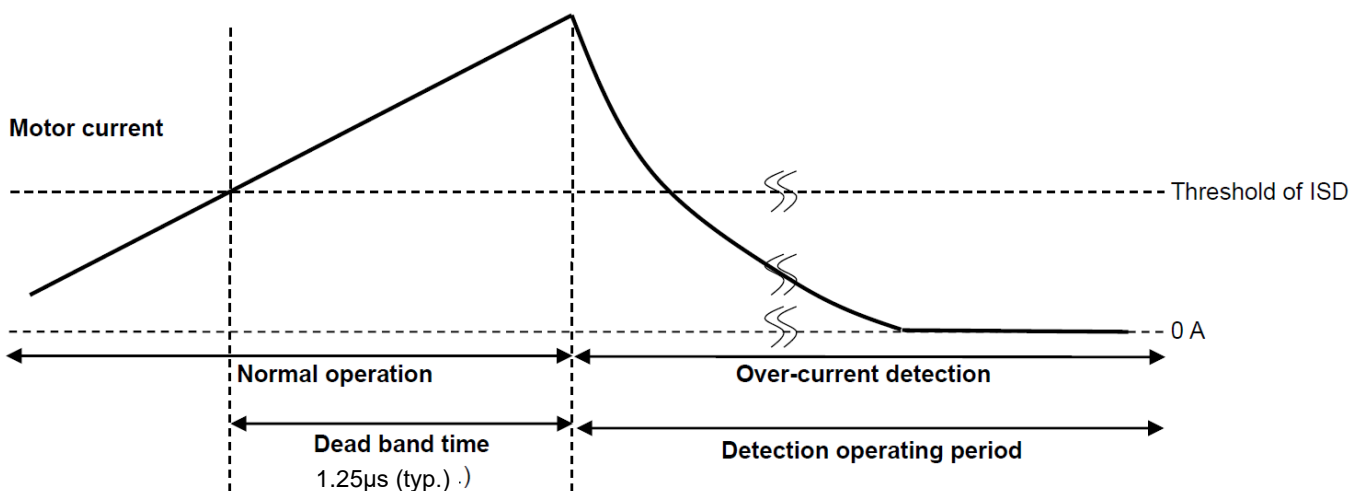

Figure 5.2 ISD operation

Note: The above time widths are not a guaranteed value, but a reference value.

6. Power consumption of the device

The power consumed in the device can be divided into the power consumed by the output transistors and the power consumed by the internal circuit including the logic section.

$$P_D = P_D(\text{out}) + P_D(\text{bias})$$

- **Power consumption of output transistors**

The power consumption ($P_D(\text{out})$) of the output transistor section is consumed in the high-side and low-side transistors in the H-bridge.

$$P_D(\text{out}) = \text{Number of H-bridges} \times I_{\text{out}}(\text{A}) \times V_{\text{DS}}(\text{V}) = 2(\text{ch}) \times I_{\text{out}}(\text{A}) \times I_{\text{out}}(\text{A}) \times R_{\text{on}}(\Omega) \dots\dots (1)$$

When the current waveform of the motor output is assumed as the ideal one (two-phase excitation / square wave), the average power of the output section can be calculated as follows.

When $R_{\text{on}} = 0.8\Omega$, $I_{\text{out}}(\text{peak: Max}) = 1.0 \text{ A}$, $V_M = 24\text{V}$, it can be calculated as follows.

$$P_D(\text{out}) = 2(\text{ch}) \times 1.0(\text{A}) \times 1.0(\text{A}) \times 0.8(\Omega) = 1.6(\text{W}) \dots\dots\dots (2)$$

- **Power consumption of Logic block and IM system**

The power consumption $P_D(\text{bias})$ of the logic block and IM system is calculated separately during operation and stop.

$$I(\text{IM3}) = 5.4 \text{ mA (typ.): During operation}$$

$$I(\text{IM2}) = 4.8 \text{ mA (typ.): During stopped}$$

The output system is connected to the V_M (12V). (Output system: the sum of the current consumed by the circuit connected to the V_M and the current consumed by switching the output stage)

The power consumption can be calculated as follows.

$$P_D(\text{bias}) = 24(\text{V}) \times 0.0054(\text{A}) = 0.13(\text{W}) \dots\dots\dots (3)$$

- **Power consumption**

The total power consumption P_D can be calculated from the values in formulas (2) and (3) as follows.

$$P_D = P_D(\text{out}) + P_D(\text{bias}) = 1.6 + 0.13 = 1.73(\text{W})$$

The power consumption when the motor is not operating (when stopped) can be calculated as follows.

$$P_D = 24(\text{V}) \times 0.0048(\text{A}) = 0.115(\text{W})$$

And power consumption can be reduced by stopping the operation by using the standby mode.

$$I_{\text{M1}} = 1\mu\text{A}(\text{max})$$

In addition, in actual motor operation, the average current will be lower than the calculated value due to the transition time of the current step and the ripple caused by constant current PWM. However, referring to the above calculated values, please perform the thermal design of the board, etc. with a margin after a sufficient evaluation of the assembled board.

7. Application circuit example

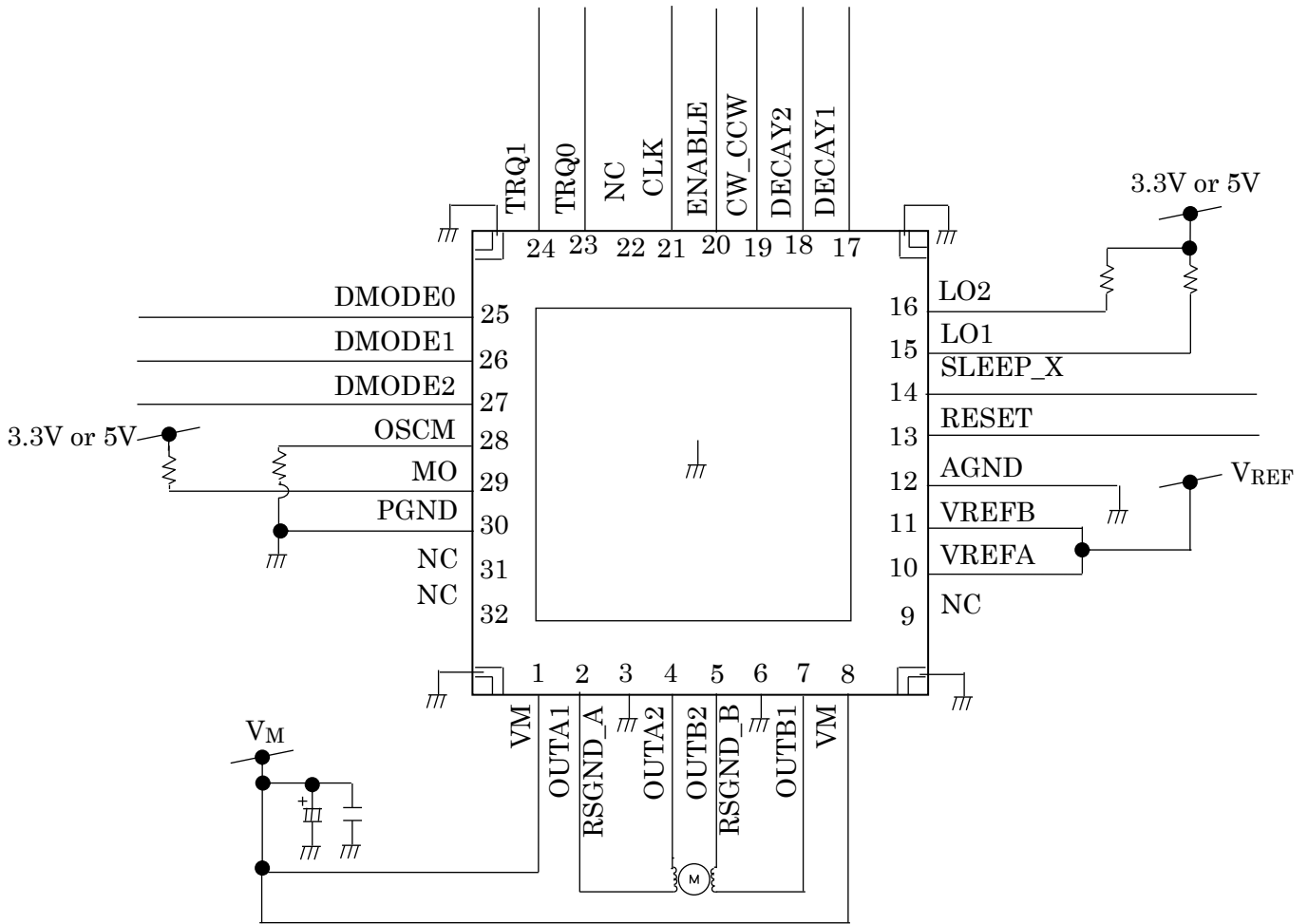

Figure 7.1 Application circuit example

The application circuit example may be simplified or some parts of them may be omitted for explanatory purposes.

7.1. Capacitor for power supply pins

Please connect a capacitor with an appropriate value to each pin for stabilizing the power supply voltage applied to the device and rejecting noises. And it is recommended to connect the capacitor as close to the device as possible. In particular, locating a ceramic capacitor close to the device is effective in suppressing fluctuations of high-frequency power supply and noise.

Table 7.1 Recommended values of capacitor at power supply pins

Item	Parts	Typical value	Recommended value range
Between VM and GND	Electrolytic capacitor	100 μ F	47 to 100 μ F
	Ceramic capacitor	0.1 μ F	0.01 to 1 μ F
Between VREF and GND	Ceramic capacitor	0.1 μ F	0.01 to 1 μ F

* Please consider connecting a capacitor between VREF and GND in accordance with application and environment.

* It is also possible to omit each part or use a capacitor other than the recommended value depending on the motor load conditions and PCB pattern layout.

7.2. Wiring pattern for power supply / GND

In this device, a large current is assumed to flow through PCB patterns especially of VM, AGND, PGND_x, OUT_x +, OUT_x- (x = A or B). Please secure a sufficient wiring pattern in order not to be affected by the wiring impedance, etc.. As the TB67S539FTG is surface mount package type, it is extremely important to dissipate heat from the heat sink on the back side of the package to the GND pattern of the board, therefore please design pattern in sufficient consideration of the thermal design.

7.3. Hughes

Please insert an appropriate fuse into the power supply line before use in order to prevent a continue large current flow in the event of an over-current or the device failure. The device may be destroyed caused by usage exceeding the absolute maximum rating, incorrect wiring, and abnormal pulse noise induced by wiring or load. As a result, a continues large current flow through the device might lead to smoke or ignition. Assuming a large current inflow and outflow cause by the device destruction, appropriate settings of fuse such as capacity, blow time, and insertion circuit location are required to minimize the effects.

In this device, the over-current detection circuit (ISD) that detects when an excessive current flows through the outputs and turns the outputs off is a built-in, but it is not guaranteed that the device is protected under all conditions. Please release the over-current state immediately after the fault detection circuit operates. Depending on the usage and conditions such as exceeding the absolute maximum ratings, the over-current detection circuit may not operate normally or the device may be damaged before the ISD operates. In addition, when over-current continues to flow, the device may be destroyed caused by heat generation depending on the usage and conditions. A secondary destruction is concerned when the over-current state continues, and non-operation of the ISD is concerned depending on the output load conditions because a dead zone period is provided in order to prevent malfunction caused by noise.

As a conclusion, considering the case of emergency please use a fuse in the power supply to prevent abnormal state form continuing.

8. PCBA design dimensions for reference

P-VQFN32-0505-0.50-004

Unit: mm

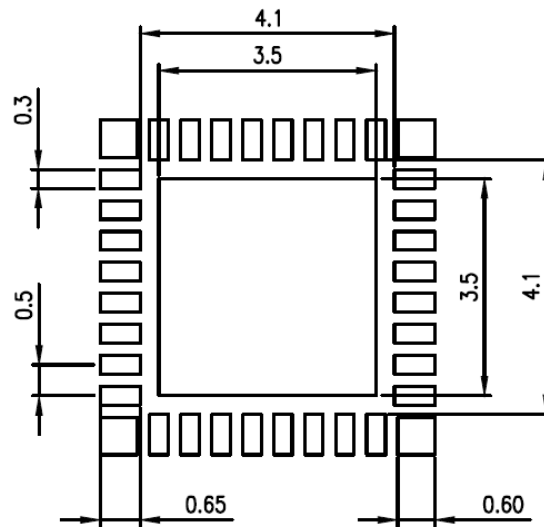

Figure 8.1 PCBA design dimensions for reference

Notes

- All linear dimensions are given in millimeters unless otherwise specified.
- This drawing is based on JEITA ET-7501 Level3 and should be treated as a reference only. TOSHIBA is not responsible for any incorrect or incomplete drawings and information.
- You are solely responsible for all aspects of your own land pattern, including but not limited to soldering processes.
- The drawing shown may not accurately represent the actual shape or dimensions.
- Before creating and producing designs and using, customers must also refer to and comply with the latest versions of all relevant TOSHIBA information and the instructions for the application that Product will be used with or for.

Note on Contents

1. Block Diagram

Some of the functional blocks, circuits, or constants in the block diagram may be omitted or simplified for explanatory purposes.

2. Equivalent Circuit

The equivalent circuit may be partially omitted or simplified to explain the circuit.

3. Timing Charts

Timing charts may be simplified for explanatory purposes.

4. Application Circuit Example

The application circuits shown in this document are provided for reference purposes only. Thorough evaluation is required, especially at the mass production design stage.

Providing these application circuit examples does not grant a license for industrial property rights.

IC Usage Considerations

Notes on handling of ICs

- (1) The absolute maximum ratings of a semiconductor device are a set of ratings that must not be exceeded, even for a moment. Do not exceed any of these ratings.
Exceeding the rating(s) may cause the device breakdown, damage or deterioration, and may result injury by explosion or combustion.
- (2) Do not insert devices in the wrong orientation or incorrectly.
Make sure that the positive and negative terminals of power supplies are connected properly.
Otherwise, the current or power consumption may exceed the absolute maximum rating, and exceeding the rating(s) may cause the device breakdown, damage or deterioration, and may result injury by explosion or combustion.
In addition, do not use any device that is applied the current with inserting in the wrong orientation or incorrectly even just one time.
- (3) Use an appropriate power supply fuse to ensure that a large current does not continuously flow in case of over-current and/or IC failure. The IC will fully break down when used under conditions that exceed its absolute maximum ratings, when the wiring is routed improperly or when an abnormal pulse noise occurs from the wiring or load, causing a large current to continuously flow and the breakdown can lead smoke or ignition. To minimize the effects of the flow of a large current in case of breakdown, appropriate settings, such as fuse capacity, fusing time and insertion circuit location, are required.
- (4) If your design includes an inductive load such as a motor coil, incorporate a protection circuit into the design to prevent device malfunction or breakdown caused by the current resulting from the inrush current at power ON or the negative current resulting from the back electromotive force at power OFF. IC breakdown may cause injury, smoke or ignition.
Use a stable power supply with ICs with built-in protection functions. If the power supply is unstable, the protection function may not operate, causing IC breakdown. IC breakdown may cause injury, smoke or ignition.
- (5) Carefully select external components (such as inputs and negative feedback capacitors) and load components (such as speakers), for example, power amp and regulator.
If there is a large amount of leakage current such as input or negative feedback condenser, the IC output DC voltage will increase. If this output voltage is connected to a speaker with low input withstand voltage, over-current or IC failure can cause smoke or ignition. (The over-current can cause smoke or ignition from the IC itself.) In particular, please pay attention when using a Bridge Tied Load (BTL) connection type IC that inputs output DC voltage to a speaker directly.

Points to remember on handling of ICs

Over-current detection circuit

Over-current detection circuits (referred to as current limiter circuits) do not necessarily protect ICs under all circumstances. If the over-current protection circuits operate against the over-current, clear the over-current status immediately.

Depending on the method of use and usage conditions, such as exceeding absolute maximum ratings can cause the over-current protection circuit to not operate properly or IC breakdown before operation. In addition, depending on the method of use and usage conditions, if over-current continues to flow for a long time after operation, the IC may generate heat resulting in breakdown.

Thermal shutdown circuit

Thermal shutdown circuits do not necessarily protect ICs under all circumstances. If the thermal shutdown circuits operate against the over temperature, clear the heat generation status immediately.

Depending on the method of use and usage conditions, such as exceeding absolute maximum ratings can cause the thermal shutdown circuit to not operate properly or IC breakdown before operation.

Heat radiation design

In using an IC with large current flow such as power amp, regulator or driver, please design the device so that heat is appropriately radiated, not to exceed the specified junction temperature (T_j) at any time and condition. These ICs generate heat even during normal use. An inadequate IC heat radiation design can lead to decrease in IC life, deterioration of IC characteristics or IC breakdown. In addition, please design the device taking into consideration the effect of IC heat radiation with peripheral components.

Back-EMF

When a motor reverses the rotation direction, stops or slows down abruptly, a current flow back to the motor's power supply due to the effect of back-EMF. If the current sink capability of the power supply is small, the device's motor power supply and output pins might be exposed to conditions beyond absolute maximum ratings. To avoid this problem, take the effect of back-EMF into consideration in system design.

RESTRICTIONS ON PRODUCT USE

Toshiba Corporation and its subsidiaries and affiliates are collectively referred to as "TOSHIBA". Hardware, software and systems described in this document are collectively referred to as "Product".

- TOSHIBA reserves the right to make changes to the information in this document and related Product without notice.
- This document and any information herein may not be reproduced without prior written permission from TOSHIBA. Even with TOSHIBA's written permission, reproduction is permissible only if reproduction is without alteration/omission.
- Though TOSHIBA works continually to improve Product's quality and reliability, Product can malfunction or fail. Customers are responsible for complying with safety standards and for providing adequate designs and safeguards for their hardware, software and systems which minimize risk and avoid situations in which a malfunction or failure of Product could cause loss of human life, bodily injury or damage to property, including data loss or corruption. Before customers use the Product, create designs including the Product, or incorporate the Product into their own applications, customers must also refer to and comply with (a) the latest versions of all relevant TOSHIBA information, including without limitation, this document, the specifications, the data sheets and application notes for Product and the precautions and conditions set forth in the "TOSHIBA Semiconductor Reliability Handbook" and (b) the instructions for the application with which the Product will be used with or for. Customers are solely responsible for all aspects of their own product design or applications, including but not limited to (a) determining the appropriateness of the use of this Product in such design or applications; (b) evaluating and determining the applicability of any information contained in this document, or in charts, diagrams, programs, algorithms, sample application circuits, or any other referenced documents; and (c) validating all operating parameters for such designs and applications. **TOSHIBA ASSUMES NO LIABILITY FOR CUSTOMERS' PRODUCT DESIGN OR APPLICATIONS.**
- **PRODUCT IS NEITHER INTENDED NOR WARRANTED FOR USE IN EQUIPMENTS OR SYSTEMS THAT REQUIRE EXTRAORDINARILY HIGH LEVELS OF QUALITY AND/OR RELIABILITY, AND/OR A MALFUNCTION OR FAILURE OF WHICH MAY CAUSE LOSS OF HUMAN LIFE, BODILY INJURY, SERIOUS PROPERTY DAMAGE AND/OR SERIOUS PUBLIC IMPACT ("UNINTENDED USE").** Except for specific applications as expressly stated in this document, Unintended Use includes, without limitation, equipment used in nuclear facilities, equipment used in the aerospace industry, lifesaving and/or life supporting medical equipment, equipment used for automobiles, trains, ships and other transportation, traffic signaling equipment, equipment used to control combustions or explosions, safety devices, elevators and escalators, and devices related to power plant. **IF YOU USE PRODUCT FOR UNINTENDED USE, TOSHIBA ASSUMES NO LIABILITY FOR PRODUCT.** For details, please contact your TOSHIBA sales representative or contact us via our website.
- Do not disassemble, analyze, reverse-engineer, alter, modify, translate or copy Product, whether in whole or in part.
- Product shall not be used for or incorporated into any products or systems whose manufacture, use, or sale is prohibited under any applicable laws or regulations.
- The information contained herein is presented only as guidance for Product use. No responsibility is assumed by TOSHIBA for any infringement of patents or any other intellectual property rights of third parties that may result from the use of Product. No license to any intellectual property right is granted by this document, whether express or implied, by estoppel or otherwise.
- **ABSENT A WRITTEN SIGNED AGREEMENT, EXCEPT AS PROVIDED IN THE RELEVANT TERMS AND CONDITIONS OF SALE FOR PRODUCT, AND TO THE MAXIMUM EXTENT ALLOWABLE BY LAW, TOSHIBA (1) ASSUMES NO LIABILITY WHATSOEVER, INCLUDING WITHOUT LIMITATION, INDIRECT, CONSEQUENTIAL, SPECIAL, OR INCIDENTAL DAMAGES OR LOSS, INCLUDING WITHOUT LIMITATION, LOSS OF PROFITS, LOSS OF OPPORTUNITIES, BUSINESS INTERRUPTION AND LOSS OF DATA, AND (2) DISCLAIMS ANY AND ALL EXPRESS OR IMPLIED WARRANTIES AND CONDITIONS RELATED TO SALE, USE OF PRODUCT, OR INFORMATION, INCLUDING WARRANTIES OR CONDITIONS OF MERCHANTABILITY, FITNESS FOR A PARTICULAR PURPOSE, ACCURACY OF INFORMATION, OR NONINFRINGEMENT.**
- Do not use or otherwise make available Product or related software or technology for any military purposes, including without limitation, for the design, development, use, stockpiling or manufacturing of nuclear, chemical, or biological weapons or missile technology products (mass destruction weapons). Product and related software and technology may be controlled under the applicable export laws and regulations including, without limitation, the Japanese Foreign Exchange and Foreign Trade Law and the U.S. Export Administration Regulations. Export and re-export of Product or related software or technology are strictly prohibited except in compliance with all applicable export laws and regulations.
- Please contact your TOSHIBA sales representative for details as to environmental matters such as the RoHS compatibility of Product. Please use Product in compliance with all applicable laws and regulations that regulate the inclusion or use of controlled substances, including without limitation, the EU RoHS Directive. **TOSHIBA ASSUMES NO LIABILITY FOR DAMAGES OR LOSSES OCCURRING AS A RESULT OF NONCOMPLIANCE WITH APPLICABLE LAWS AND REGULATIONS.**

TOSHIBA ELECTRONIC DEVICES & STORAGE CORPORATION

<https://toshiba.semicon-storage.com/>