

TB6560AFG Usage Considerations

The TB6560AFG drives a two-phase bipolar stepping motor.

It drives at a constant current by PWM control. The TB6560AFG can be used in applications that require 2-phase, 1-2-phase, 2W1-2-phase and 4W1-2-phase excitation modes. It is capable of forward and reverse driving of a two-phase bipolar stepping motor using only a clock signal.

1. Power Supply Voltage

(1) Operating Range of Power Supply Voltage

Characteristic	Symbol	Operating Voltage Range	Absolute Maximum Ratings	Unit
Control power supply voltage	V _{DD}	4.5 to 5.5	6	V
Motor power supply voltage	V _{MA} , V _{MB}	4.5 to 34	40	V

The absolute maximum ratings of a semiconductor device are a set of ratings that must not be exceeded, even for a moment. Do not exceed any of these ratings.

If a voltage outside the operating range as follows; $4.5 \leq V_{DD} \leq 5.5$, $4.5 \leq V_{MA/B} \leq 34$, $V_{DD} \leq V_{MA/B}$ is applied, the IC may not operate properly or the IC and peripheral parts may be permanently damaged. Ensure that the voltage range does not exceed the upper and lower limits of the specified range.

(2) Power-on Sequence with Control Input Signals

Turn on V_{DD}. Then, when the V_{DD} voltage has stabilized, turn on V_{MA/B}.

Hold the control input pins Low while turning on V_{DD} and V_{MA/B}.

(All the control input pins are internally pulled down.)

After V_{DD} and V_{MA/B} completely stabilizes at the rated voltages, the $\overline{\text{RESET}}$ and ENABLE pins can be set High. If this sequence is not properly followed, the IC may not operate correctly, or the IC and the peripheral parts may be damaged.

When $\overline{\text{RESET}}$ is released High, the CLK signal is applied and excitation is started. Only after ENABLE is also set High, outputs are enabled. When only $\overline{\text{RESET}}$ is set High, outputs are disabled and only the internal counter advances. Likewise, when only ENABLE is set High, the excitation will not be performed even if the CLK signal is applied and the outputs will remain in the initial state.

An example of a control input sequence is shown below.

A power-off sequence should be the reverse of this sequence.

Recommended Control Input Sequence is indicated below.

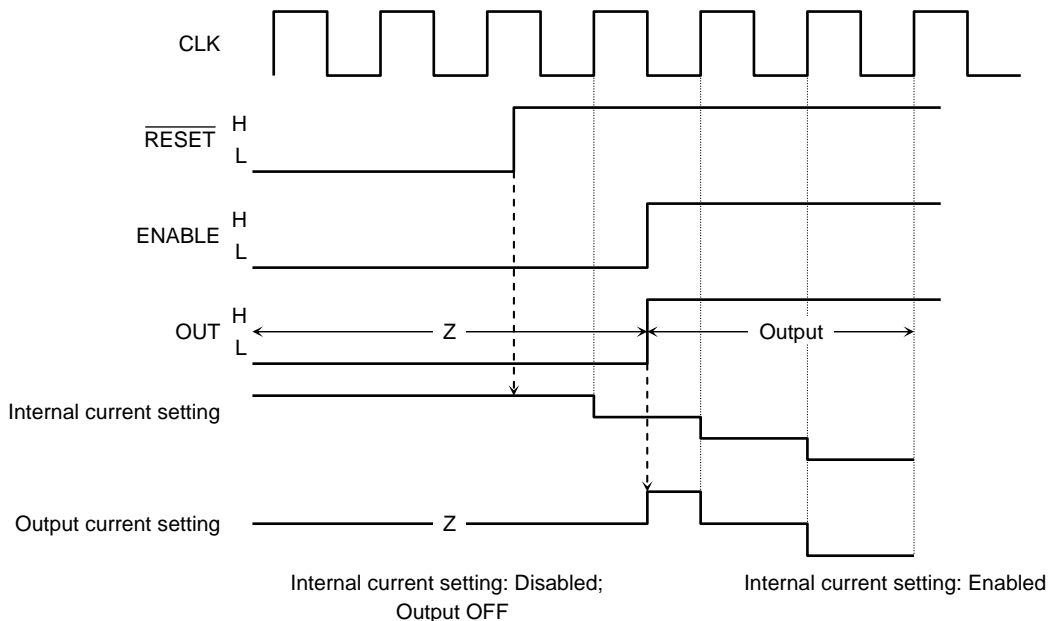

2. Output Current

The absolute maximum rating is 2.5 A per phase, and the upper limit of operating current is 1.5 A per phase. The absolute maximum ratings of a semiconductor device are a set of ratings that must not be exceeded, even for a moment. Do not exceed any of these ratings.

The average permissible current is restricted by total power dissipation. Please use the IC within the range of the power dissipation.

3. Output ON-Resistance

Output ON-resistances for H-bridge: 0.7 Ω typical and 1.0 Ω maximum (upper and lower sum) with a test condition of the $I_{out} = 1.5$ A

4. Output Residual Voltage

The residual voltages of the M_O and Protect output pins are up to 0.5 V each where $I_o = 1$ mA.

5. Power Dissipation

PD-Ta curve of the TB6560AFG in each mounted condition are shown below.

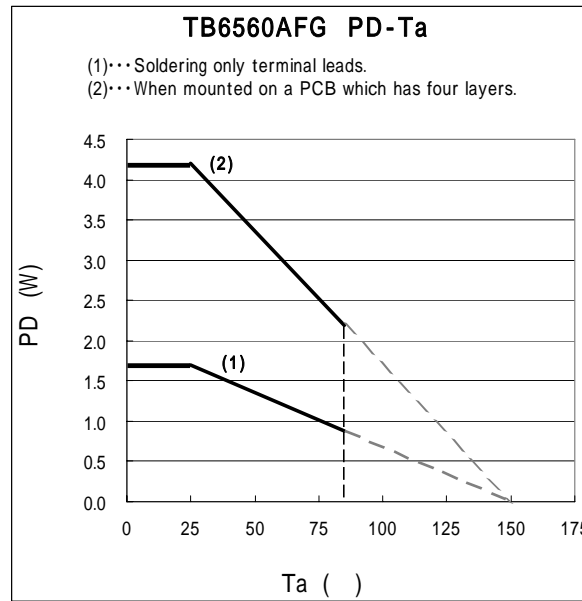

Power consumption in each excitation mode is calculated at a rough estimate as follows:

- 2-phase excitation

$$P = V_{DD} \times I_{DD} + (R_{on}(U + L) \times I_o \times I_o) \times 2$$
- 1-2 phase excitation

$$P = V_{DD} \times I_{DD} + \{(R_{on}(U + L) \times I_o \times 100\% \times I_o \times 100\% \times (2/8)) + (R_{on}(U + L) \times I_o \times 71\% \times I_o \times 71\% \times (4/8)) + (R_{on}(U + L) \times I_o \times 0\% \times I_o \times 0\% \times (2/8))\} \times 2$$
- 2W1-2 phase excitation

$$P = V_{DD} \times I_{DD} + \{(R_{on}(U + L) \times I_o \times 100\% \times I_o \times 100\% \times (2/32)) + (R_{on}(U + L) \times I_o \times 98\% \times I_o \times 98\% \times (4/32)) + (R_{on}(U + L) \times I_o \times 92\% \times I_o \times 92\% \times (4/32)) + (R_{on}(U + L) \times I_o \times 83\% \times I_o \times 83\% \times (4/32)) + (R_{on}(U + L) \times I_o \times 71\% \times I_o \times 71\% \times (4/32)) + (R_{on}(U + L) \times I_o \times 56\% \times I_o \times 56\% \times (4/32)) + (R_{on}(U + L) \times I_o \times 38\% \times I_o \times 38\% \times (4/32)) + (R_{on}(U + L) \times I_o \times 20\% \times I_o \times 20\% \times (4/32)) + (R_{on}(U + L) \times I_o \times 0\% \times I_o \times 0\% \times (2/32))\} \times 2$$
- 4W1-2 phase excitation

$$P = V_{DD} \times I_{DD} + \{(R_{on}(U + L) \times I_o \times 100\% \times I_o \times 100\% \times (2/64)) + (R_{on}(U + L) \times I_o \times 98\% \times I_o \times 98\% \times (4/64)) + (R_{on}(U + L) \times I_o \times 96\% \times I_o \times 96\% \times (4/64)) + (R_{on}(U + L) \times I_o \times 92\% \times I_o \times 92\% \times (4/64)) + (R_{on}(U + L) \times I_o \times 88\% \times I_o \times 88\% \times (4/64)) + (R_{on}(U + L) \times I_o \times 83\% \times I_o \times 83\% \times (4/64)) + (R_{on}(U + L) \times I_o \times 77\% \times I_o \times 77\% \times (4/64)) + (R_{on}(U + L) \times I_o \times 71\% \times I_o \times 71\% \times (4/64)) + (R_{on}(U + L) \times I_o \times 63\% \times I_o \times 63\% \times (4/64)) + (R_{on}(U + L) \times I_o \times 56\% \times I_o \times 56\% \times (4/64)) + (R_{on}(U + L) \times I_o \times 47\% \times I_o \times 47\% \times (4/64)) + (R_{on}(U + L) \times I_o \times 38\% \times I_o \times 38\% \times (4/64)) + (R_{on}(U + L) \times I_o \times 29\% \times I_o \times 29\% \times (4/64)) + (R_{on}(U + L) \times I_o \times 20\% \times I_o \times 20\% \times (4/64)) + (R_{on}(U + L) \times I_o \times 10\% \times I_o \times 10\% \times (4/64)) + (R_{on}(U + L) \times I_o \times 10\% \times I_o \times 10\% \times (2/64))\} \times 2$$

(Notes)

- V_{DD} = Power supply pin for control block
- I_{DD} = Supply current for control block
- R_{on}(U + L) = Output on-resistance (Upper + lower)
- I_o = Output current (Peak value of 100%)

Please confirm the operation in the actual operation conditions because thermal characteristics changes widely depending on the discharge characteristics of the board and the transient characteristics in the mounted state.

Heat loss can be promoted by taking the GND pattern of the print board widely. Usage of a heat sink is recommended to promote more heat loss.

6. Application Circuit Example

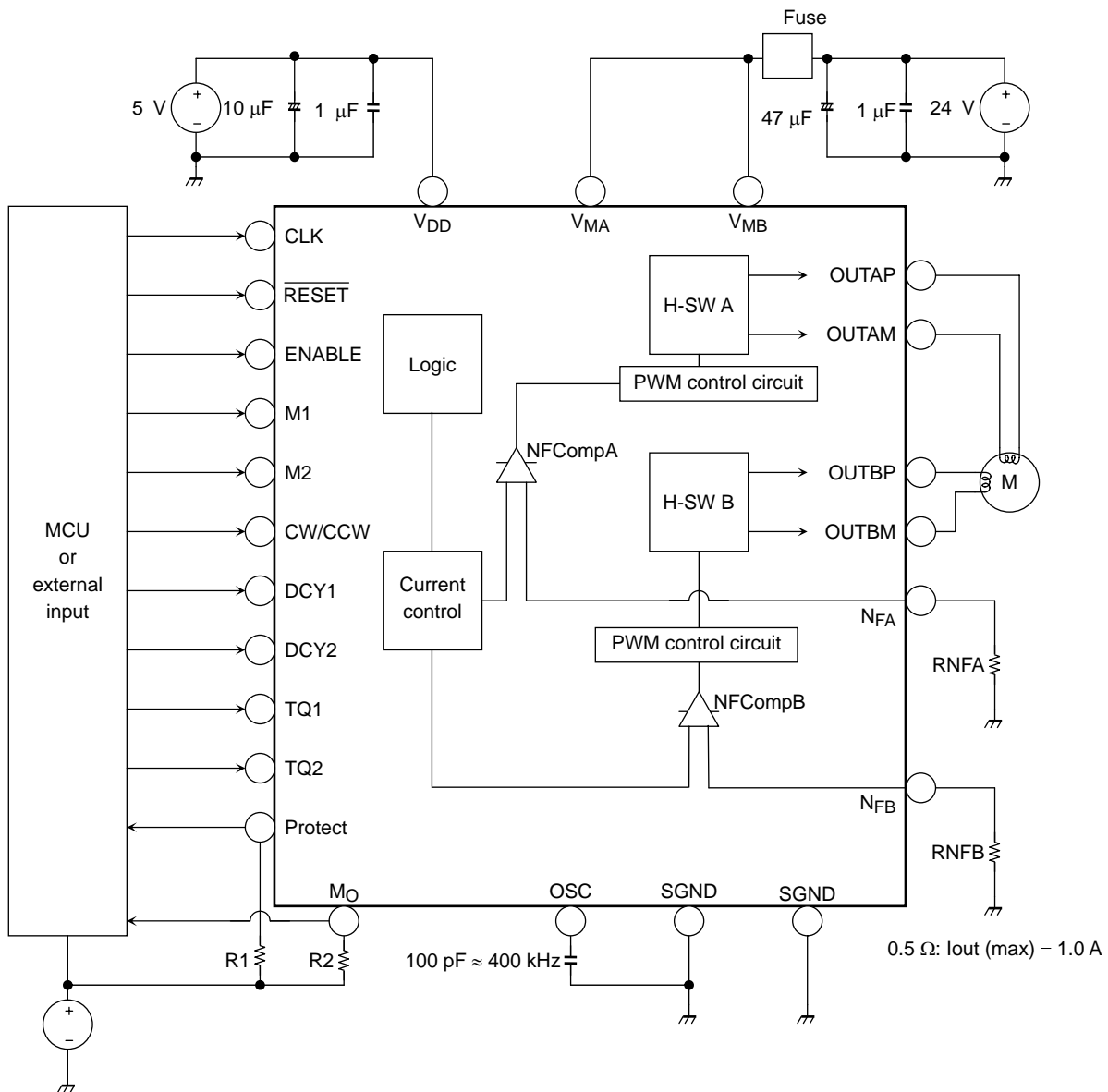

Note: Capacitors for the power supply lines should be connected as close to the IC as possible.

Usage Considerations

- A large current might abruptly flow through the IC in case of a short-circuit across its outputs, a short-circuit to power supply or a short-circuit to ground, leading to a damage of the IC. Also, the IC or peripheral parts may be permanently damaged or emit smoke or fire resulting in injury especially if a power supply pin (VDD, VMA and VMB) or an output pin (OUTAP, OUTAM, OUTBP and OUTBM) is short-circuited to adjacent or any other pins. These possibilities should be fully considered in the design of the output, VDD, VM, and ground lines.
- A fuse should be connected to the power supply line. The rated maximum current of the TB6560AFG is 2.5 A/phase. Considering those maximum ratings, an appropriate fuse must be selected depending on operating conditions of a motor to be used. Toshiba recommends that a fast-blow fuse be used.
- The power-on sequence described on page 2 must be properly followed.
- If a voltage outside the operating range specified on page 1 ($4.5 \leq V_{DD} \leq 5.5$, $4.5 \leq V_{MA/B} \leq 34$, $V_{DD} \leq V_{MA/B}$) is applied, the IC may not operate properly or the IC and peripheral parts may be permanently damaged. Ensure that the voltage range does not exceed the upper and lower limits of the specified range.

(1) Capacitors for the Power Supply Lines

Capacitors for the power supply lines between VDD and GND should be connected as close to the IC as possible.

Recommended Value

Characteristic	Recommended Value	Remarks
V _{DD} – GND	10 μF to 100 μF	Electrolytic capacitor
	0.1 μF to 1 μF	Ceramic capacitor

(2) Capacitors for V_M Terminal

Capacitors for V_M terminal between V_M and GND should be connected as close to the IC as possible.

Recommended Value

Characteristic	Recommended Value	Remarks
V _M – GND	10 μF to 100 μF	Electrolytic capacitor
	0.1 μF to 1 μF	Ceramic capacitor

(3) Resistances for NFA and NFB Terminals

The resistance of NFA terminal (RNFA) and that of NFB terminal (RNFB) determine the maximum current of phase A and B.

The reference current for the constant current operation should be set by the external resistance. When voltage for NFA and NFB terminals become 0.5 V or more (in case torque is 100 %.), it stops charging and the current which is over the reference value does not flow.

$$I_{out} (A) = 0.5 V / R_{NF} (\Omega)$$

Example: When the maximum current is 1 A, external resistance is 0.5 Ω.

(4) Adjusting the External Capacitor Value (C_{OSC}) and Minimum Clock Pulse Width (t_w (CLK))

A triangular-wave is generated internally by CR oscillation. The capacitor is externally connected to the OSC pin. The recommended capacitor value is between 100 pF and 1000 pF.

Approximate equation: $f_{osc} = 1 / \{C_{OSC} \times 1.5 \times (10 / C_{OSC} + 1) / 66\} + 1000$ kHz
 (Since this is an approximation formula, the calculation result may not be exactly equal to the actual value.)

The approximate values are shown below.

The minimum clock pulse width (t_w(CLK)) corresponds to the external capacitor (C_{OSC}) as follows:

Capacitor	Oscillating Frequency	Minimum Clock Pulse Width t _w (CLK) (Note)
1000 pF	44 kHz	90 μs
330 pF	130 kHz	30 μs
100 pF	400 kHz	10 μs

Note: When the frequency of an input clock signal is high, the C_{OSC} value should be small so that the duty cycle of an input clock pulse does not become extremely high (should be around 50% or lower).

- (5) To set decay mode (current decay by DCY1 and DCY2 terminals), set the appropriate mode by monitoring the waveform of motor coil current. The appropriate mode depends on the conditions (usage motor, power supply voltage, CLK frequency, and so on).

Example: Set current decay

(a) Normal mode
(First decay = 0%, DCY1 = Low,
DCY2 = Low)

(b) 50%Decay mode
(First decay = 50%, DCY1 = Low,
DCY2 = High)

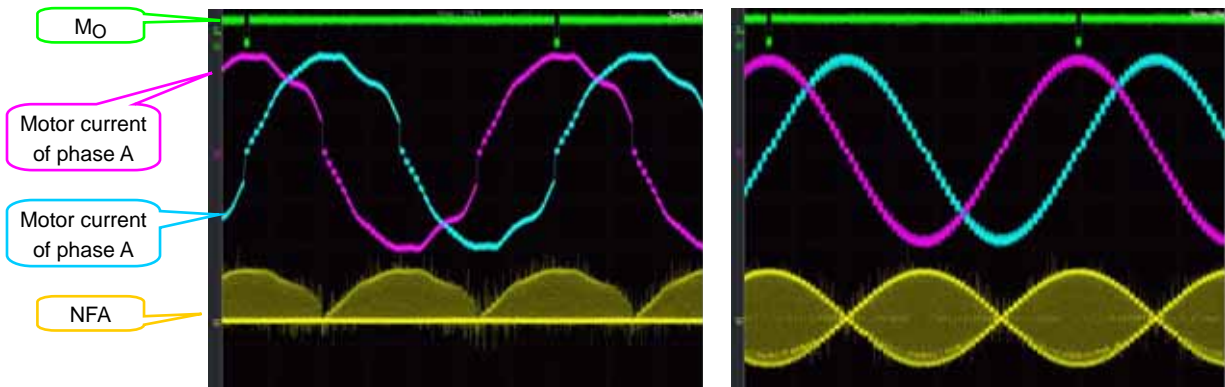

7. Excitation Mode Setting

The excitation mode can be selected from 2 phase, 1-2 phase, 2W1-2 phase, and 4W1-2 phase modes using the M1 and M2 inputs. It is capable of forward and reverse driving of a two-phase bipolar stepping motor with CW and CCW terminals using only a clock signal.

2-Phase Excitation (M1: L, M2: L, CW mode)

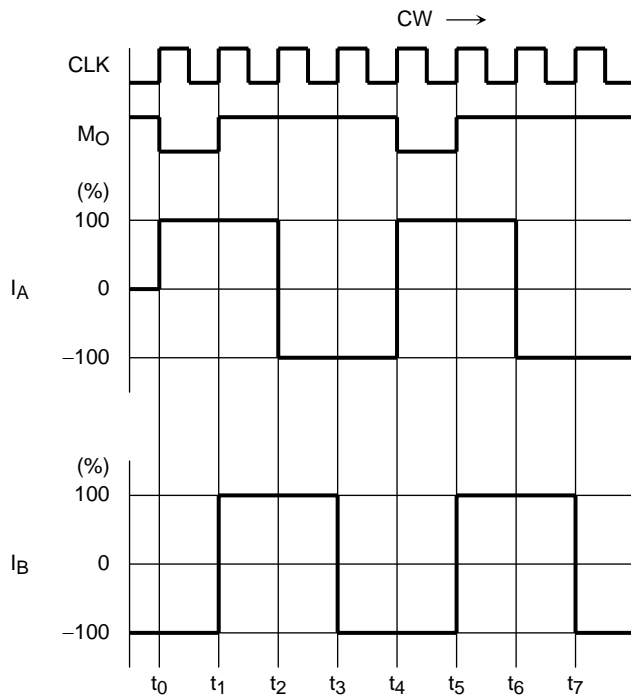

1-2 Phase Excitation (M1: H, M2: L, CW mode)

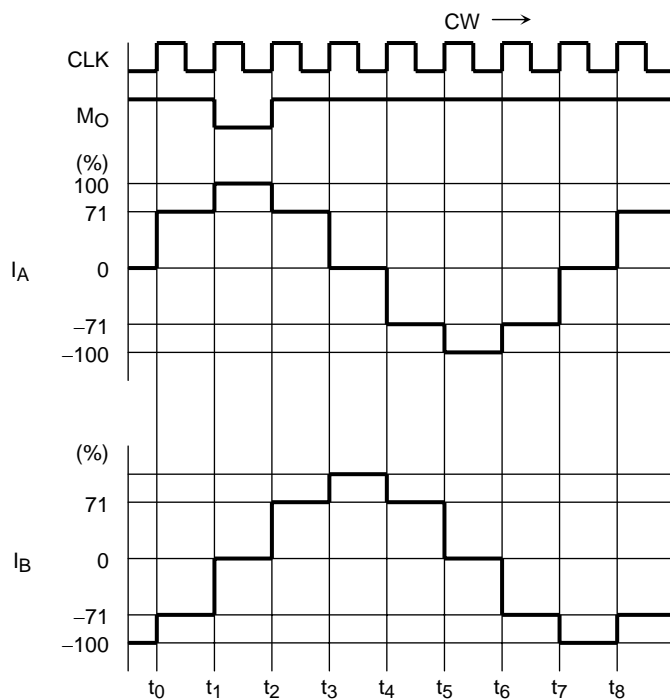

2W1-2 Phase Excitation (M1: H, M2: H, CW mode)

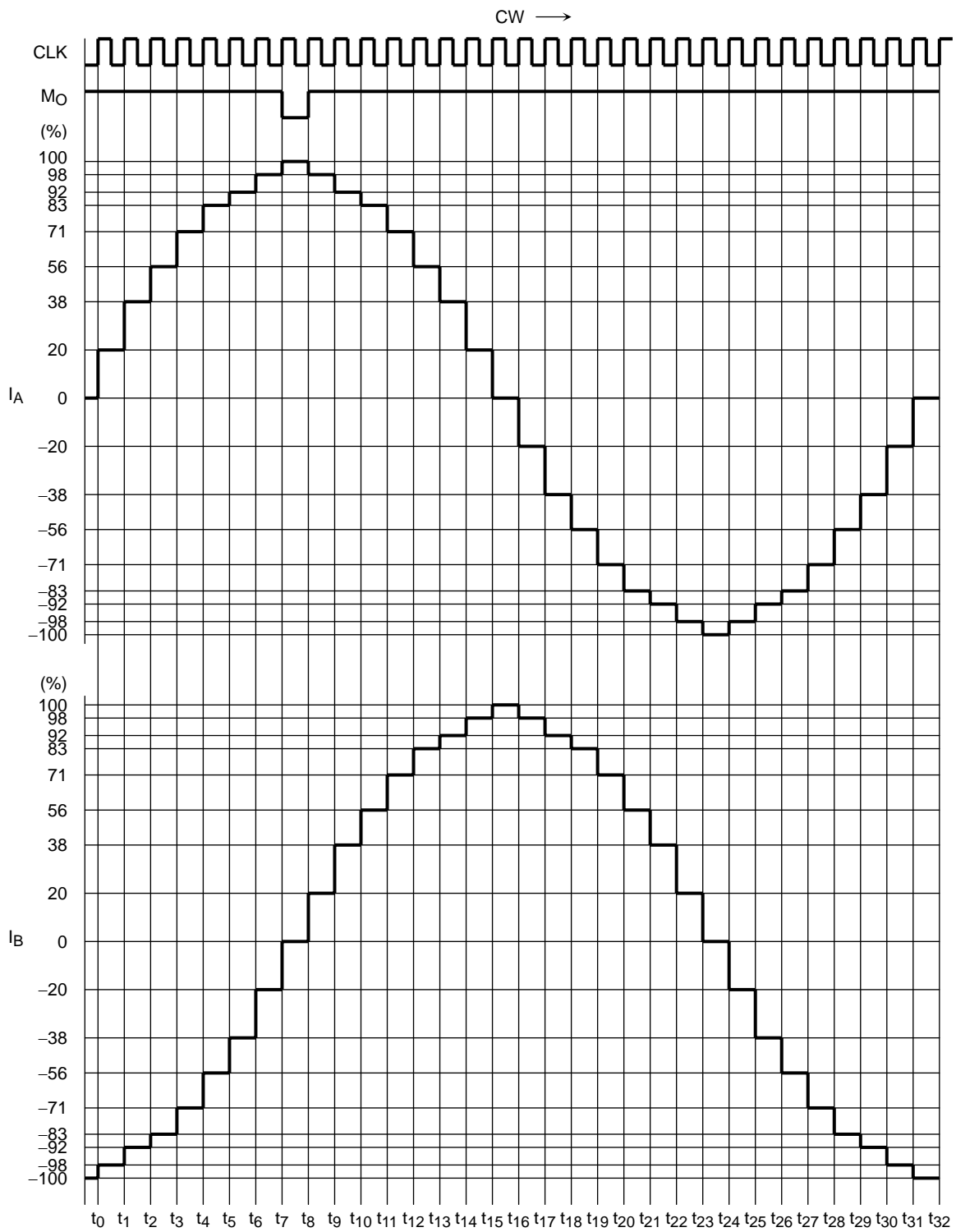

4W1-2 Phase Excitation (M1: L, M2: H, CW mode)

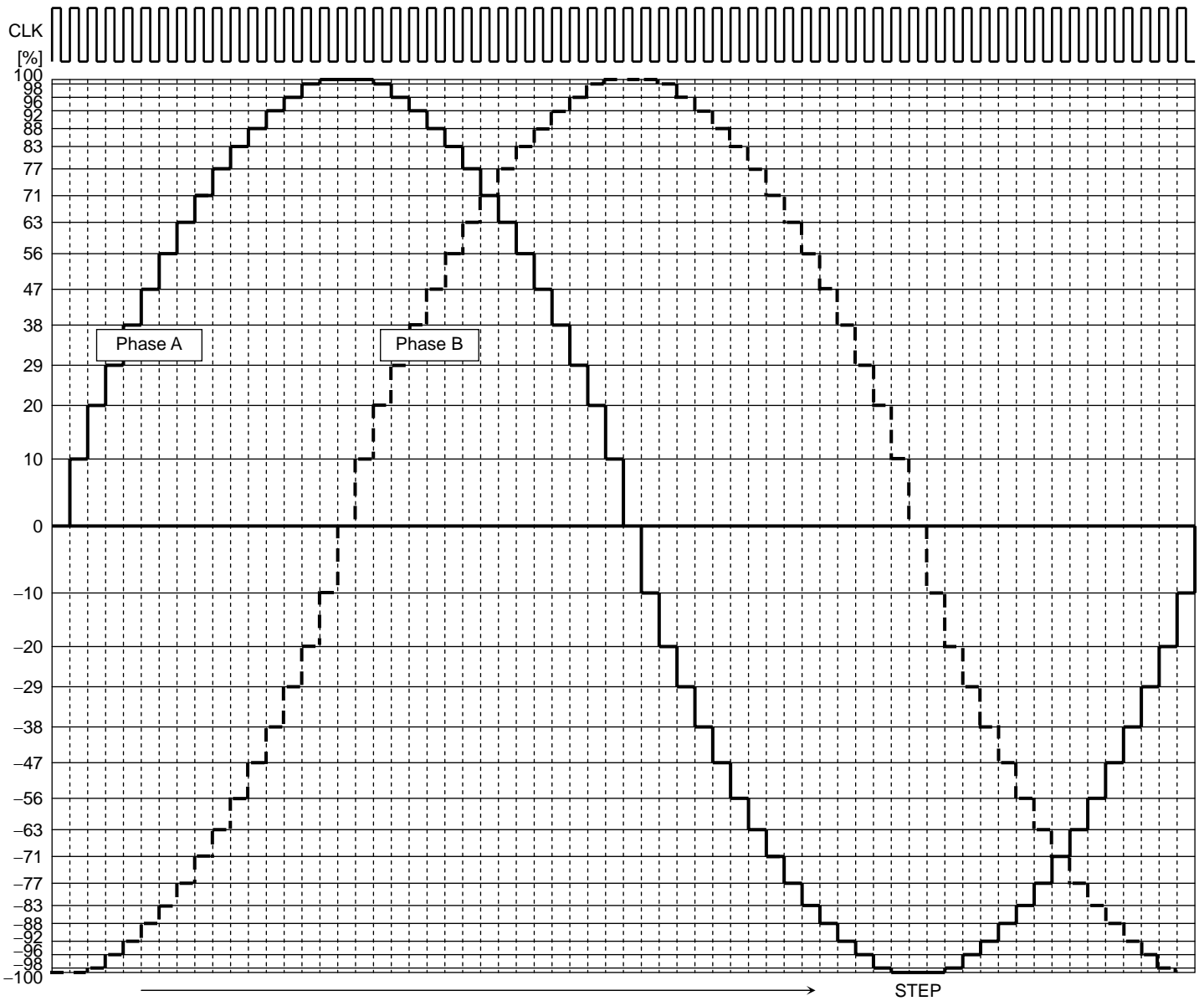

Input Signal Example

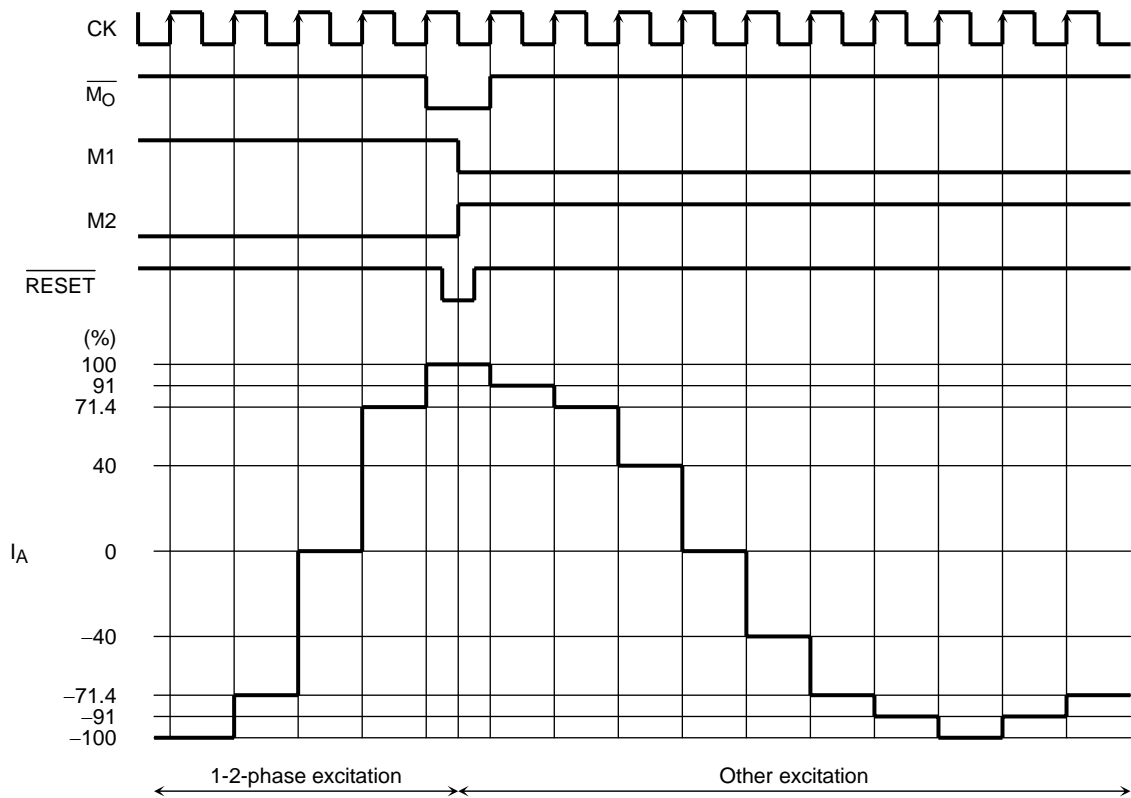

It is recommended that the state of the M1 and M2 pins be changed after setting the $\overline{\text{RESET}}$ signal Low during the Initial state ($\overline{\text{M0}} = \text{Low}$). Even when the $\overline{\text{M0}}$ signal is Low, changing the M1 and M2 signals without setting the $\overline{\text{RESET}}$ signal Low may cause a discontinuity in the current waveform.

RESTRICTIONS ON PRODUCT USE

- Toshiba Corporation, and its subsidiaries and affiliates (collectively "TOSHIBA"), reserve the right to make changes to the information in this document, and related hardware, software and systems (collectively "Product") without notice.
- This document and any information herein may not be reproduced without prior written permission from TOSHIBA. Even with TOSHIBA's written permission, reproduction is permissible only if reproduction is without alteration/omission.
- Though TOSHIBA works continually to improve Product's quality and reliability, Product can malfunction or fail. Customers are responsible for complying with safety standards and for providing adequate designs and safeguards for their hardware, software and systems which minimize risk and avoid situations in which a malfunction or failure of Product could cause loss of human life, bodily injury or damage to property, including data loss or corruption. Before creating and producing designs and using, customers must also refer to and comply with (a) the latest versions of all relevant TOSHIBA information, including without limitation, this document, the specifications, the data sheets and application notes for Product and the precautions and conditions set forth in the "TOSHIBA Semiconductor Reliability Handbook" and (b) the instructions for the application that Product will be used with or for. Customers are solely responsible for all aspects of their own product design or applications, including but not limited to (a) determining the appropriateness of the use of this Product in such design or applications; (b) evaluating and determining the applicability of any information contained in this document, or in charts, diagrams, programs, algorithms, sample application circuits, or any other referenced documents; and (c) validating all operating parameters for such designs and applications. **TOSHIBA ASSUMES NO LIABILITY FOR CUSTOMERS' PRODUCT DESIGN OR APPLICATIONS.**
- Product is intended for use in general electronics applications (e.g., computers, personal equipment, office equipment, measuring equipment, industrial robots and home electronics appliances) or for specific applications as expressly stated in this document. Product is neither intended nor warranted for use in equipment or systems that require extraordinarily high levels of quality and/or reliability and/or a malfunction or failure of which may cause loss of human life, bodily injury, serious property damage or serious public impact ("Unintended Use"). Unintended Use includes, without limitation, equipment used in nuclear facilities, equipment used in the aerospace industry, medical equipment, equipment used for automobiles, trains, ships and other transportation, traffic signaling equipment, equipment used to control combustions or explosions, safety devices, elevators and escalators, devices related to electric power, and equipment used in finance-related fields. Do not use Product for Unintended Use unless specifically permitted in this document.
- Do not disassemble, analyze, reverse-engineer, alter, modify, translate or copy Product, whether in whole or in part.
- Product shall not be used for or incorporated into any products or systems whose manufacture, use, or sale is prohibited under any applicable laws or regulations.
- The information contained herein is presented only as guidance for Product use. No responsibility is assumed by TOSHIBA for any infringement of patents or any other intellectual property rights of third parties that may result from the use of Product. No license to any intellectual property right is granted by this document, whether express or implied, by estoppel or otherwise.
- **ABSENT A WRITTEN SIGNED AGREEMENT, EXCEPT AS PROVIDED IN THE RELEVANT TERMS AND CONDITIONS OF SALE FOR PRODUCT, AND TO THE MAXIMUM EXTENT ALLOWABLE BY LAW, TOSHIBA (1) ASSUMES NO LIABILITY WHATSOEVER, INCLUDING WITHOUT LIMITATION, INDIRECT, CONSEQUENTIAL, SPECIAL, OR INCIDENTAL DAMAGES OR LOSS, INCLUDING WITHOUT LIMITATION, LOSS OF PROFITS, LOSS OF OPPORTUNITIES, BUSINESS INTERRUPTION AND LOSS OF DATA, AND (2) DISCLAIMS ANY AND ALL EXPRESS OR IMPLIED WARRANTIES AND CONDITIONS RELATED TO SALE, USE OF PRODUCT, OR INFORMATION, INCLUDING WARRANTIES OR CONDITIONS OF MERCHANTABILITY, FITNESS FOR A PARTICULAR PURPOSE, ACCURACY OF INFORMATION, OR NONINFRINGEMENT.**
- Do not use or otherwise make available Product or related software or technology for any military purposes, including without limitation, for the design, development, use, stockpiling or manufacturing of nuclear, chemical, or biological weapons or missile technology products (mass destruction weapons). Product and related software and technology may be controlled under the Japanese Foreign Exchange and Foreign Trade Law and the U.S. Export Administration Regulations. Export and re-export of Product or related software or technology are strictly prohibited except in compliance with all applicable export laws and regulations.
- Please contact your TOSHIBA sales representative for details as to environmental matters such as the RoHS compatibility of Product. Please use Product in compliance with all applicable laws and regulations that regulate the inclusion or use of controlled substances, including without limitation, the EU RoHS Directive. TOSHIBA assumes no liability for damages or losses occurring as a result of noncompliance with applicable laws and regulations.