

TOSHIBA

TOSHIBA Original CMOS 16-Bit Microcontroller

TLCS-900/L1 Series

TMP91FY42FG

Not Recommended
for New Design

TOSHIBA CORPORATION

Semiconductor Company

Preface

Thank you very much for making use of Toshiba microcomputer LSIs.
Before use this LSI, refer the section, "Points of Note and Restrictions".
Especially, take care below cautions.

Not Recommended
for New Design

CMOS 16-Bit Microcontrollers TMP91FY42FG

1. Outline and Features

TMP91FY42F is a high-speed 16-bit microcontroller designed for the control of various mid- to large-scale equipment.

TMP91FY42FG comes in a 100-pin flat package.

Listed below are the features.

- (1) High-speed 16-bit CPU (900/L1 CPU)
 - Instruction mnemonics are upward-compatible with TLCS-90/900
 - General-purpose registers and register banks
 - 16 Mbytes of linear address space
 - 16-bit multiplication and division instructions; bit transfer and arithmetic instructions
 - Micro DMA: 4-channels (593 ns/2 bytes at 27 MHz)
- (2) Minimum instruction execution time: 148 ns (at 27 MHz)

RESTRICTIONS ON PRODUCT USE

060925EBP

- The information contained herein is subject to change without notice. 021023_D
- TOSHIBA is continually working to improve the quality and reliability of its products. Nevertheless, semiconductor devices in general can malfunction or fail due to their inherent electrical sensitivity and vulnerability to physical stress. It is the responsibility of the buyer, when utilizing TOSHIBA products, to comply with the standards of safety in making a safe design for the entire system, and to avoid situations in which a malfunction or failure of such TOSHIBA products could cause loss of human life, bodily injury or damage to property.
In developing your designs, please ensure that TOSHIBA products are used within specified operating ranges as set forth in the most recent TOSHIBA products specifications. Also, please keep in mind the precautions and conditions set forth in the "Handling Guide for Semiconductor Devices," or "TOSHIBA Semiconductor Reliability Handbook" etc. 021023_A
- The TOSHIBA products listed in this document are intended for usage in general electronics applications (computer, personal equipment, office equipment, measuring equipment, industrial robotics, domestic appliances, etc.). These TOSHIBA products are neither intended nor warranted for usage in equipment that requires extraordinarily high quality and/or reliability or a malfunction or failure of which may cause loss of human life or bodily injury ("Unintended Usage"). Unintended Usage include atomic energy control instruments, airplane or spaceship instruments, transportation instruments, traffic signal instruments, combustion control instruments, medical instruments, all types of safety devices, etc. Unintended Usage of TOSHIBA products listed in this document shall be made at the customer's own risk. 021023_B
- The products described in this document shall not be used or embedded to any downstream products of which manufacture, use and/or sale are prohibited under any applicable laws and regulations. 060106_Q
- The information contained herein is presented only as a guide for the applications of our products. No responsibility is assumed by TOSHIBA for any infringements of patents or other rights of the third parties which may result from its use. No license is granted by implication or otherwise under any patent or patent rights of TOSHIBA or others. 021023_C
- The products described in this document are subject to foreign exchange and foreign trade control laws. 060925_E
- For a discussion of how the reliability of microcontrollers can be predicted, please refer to Section 1.3 of the chapter entitled Quality and Reliability Assurance/Handling Precautions. 030619_S

This product uses the Super Flash® technology under the license of Silicon Storage Technology, Inc.
Super Flash® is a registered trademark of Silicon Storage Technology, Inc.

- (3) Built-in RAM: 16 Kbytes
Built-in ROM: 256 Kbytes Flash memory
4 Kbytes mask ROM (used for booting)
- (4) External memory expansion
 - Expandable up to 16 Mbytes (shared program/data area)
 - Can simultaneously support 8-/16-bit width external data bus
... Dynamic data bus sizing
- (5) 8-bit timers: 8 channels
- (6) 16-bit timer/event counter: 2 channels
- (7) General-purpose serial interface: 2 channels
 - UART/ Synchronous mode: 2 channels
 - IrDA ver1.0 (115.2 kbps) supported: 1 channel
- (8) Serial bus interface: 1 channel
 - I²C bus mode/clock synchronous Select mode
- (9) 10-bit AD converter (built-in sample hold circuit) : 8 channels
- (10) Watchdog timer
- (11) Special timer for clock
- (12) Chip Select/Wait controller: 4 channels
- (13) Interrupts: 45 interrupts
 - 9 CPU interrupts: Software interrupt instruction and illegal instruction
 - 26 internal interrupts: Seven selectable priority levels
 - 10 external interrupts:
- (14) Input/Output ports: 81 pins
- (15) Standby function
Three HALT modes: IDLE2 (programmable), IDLE1, STOP
- (16) Clock controller
 - Clock Gear function: Select a high-frequency clock (f_c to $f_c/16$)
 - Special timer for CLOCK ($f_s = 32.768$ kHz)
- (17) Operating voltage
 - $V_{CC} = 2.7$ V to 3.6 V (f_c max = 27 MHz, flash memory read operation)
 - $V_{CC} = 3.0$ V to 3.6 V (f_c max = 27 MHz, flash memory erase/program operations)
- (18) Package
 - 100-pin LQFP: LQFP100-P-1414-0.50F

Note: This LSI does not build in Clock doubler (DFM.)

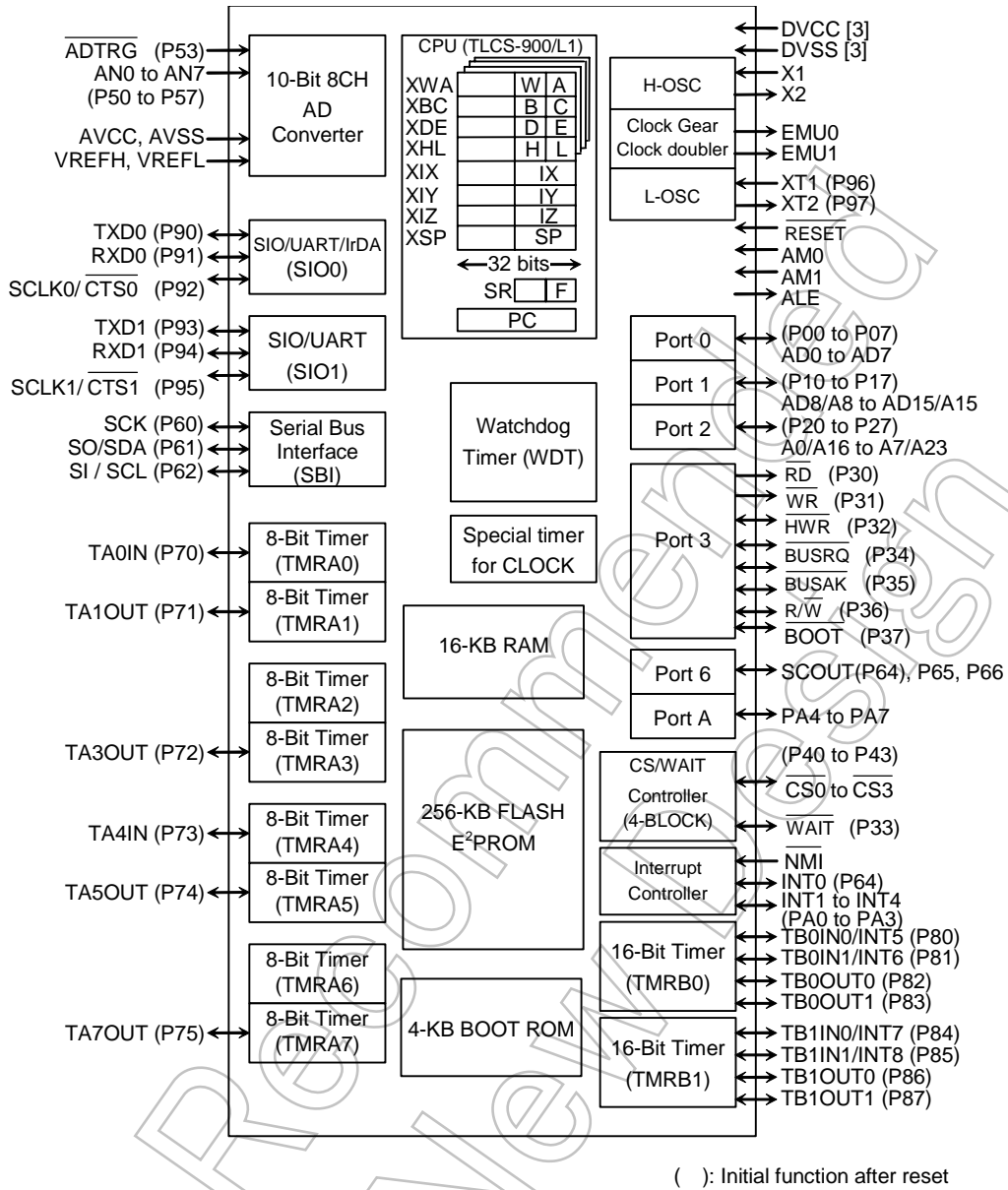

Figure 1.1 TMP91FY42F Block Diagram

2. Pin Assignment and Pin Functions

The assignment of input/output pins for the TMP91FY42, their names and functions are as follows:

2.1 Pin Assignment Diagram

Figure 2.1.1 shows the pin assignment of the TMP91FY42.

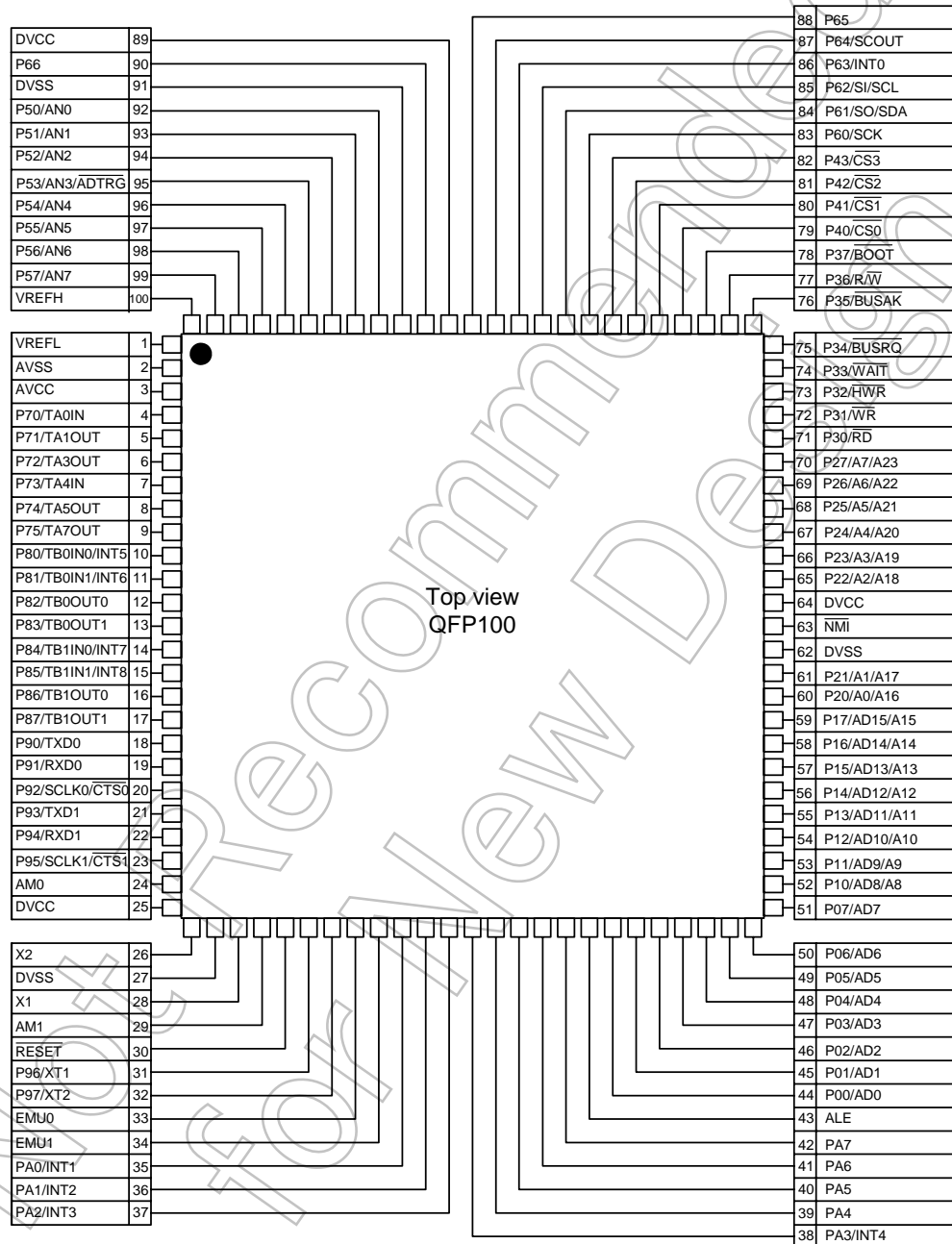

Figure 2.1.1 Pin assignment diagram (100-pin LQFP)

2.2 Pin Names and Functions

The names of the input/output pins and their functions are described below.

Table 2.2.1 Pin names and functions.

Table 2.2.1 Pin names and functions (1/3)

Pin Name	Number of Pins	I/O	Functions
P00~P07 AD0~AD7	8	I/O I/O	Port 0: I/O port that allows I/O to be selected at the bit level Address and data (lower): Bits 0 to 7 of address and data bus
P10~P17 AD8~AD15 A8~A15	8	I/O I/O Output	Port 1: I/O port that allows I/O to be selected at the bit level Address and data (upper): Bits 8 to 15 for address and data bus Address: Bits 8 to 15 of address bus
P20~P27 A0~A7 A16~A23	8	I/O Output Output	Port 2: I/O port that allows I/O to be selected at the bit level Address: Bits 0 to 7 of address bus Address: Bits 16 to 23 of address bus
P30 RD	1	Output Output	Port 30: Output port Read: Strobe signal for reading external memory This port output RD signal also case of reading internal-area by setting P3 <P30> = 0 and P3FC <P30F> = 1.
P31 WR	1	Output Output	Port 31: Output port Write: Strobe signal for writing data to pins AD0 to AD7
P32 HWR	1	I/O Output	Port 32: I/O port (with pull-up resistor) High Write: Strobe signal for writing data to pins AD8 to AD15
P33 WAIT	1	I/O Input	Port 33: I/O port (with pull-up resistor) Wait: Pin used to request CPU bus wait ((1+N) WAIT mode)
P34 BUSRQ	1	I/O Input	Port 34: I/O port (with pull-up resistor) Bus Request: Signal used to request Bus Release
P35 BUSAK	1	I/O Output	Port 35: I/O port (with pull-up resistor) Bus Acknowledge: Signal used to acknowledge Bus Release
P36 R/W	1	I/O Output	Port 36: I/O port (with pull-up resistor) Read/Write: 1 represents Read or Dummy cycle; 0 represents Write cycle.
P37 BOOT	1	I/O Input	Port 36: I/O port (with pull-up resistor) This pin sets single boot mode. When released reset, Single boot mode is started at P37=Low level.
P40 CS0	1	I/O Output	Port 40: I/O port (with pull-up resistor) Chip Select 0: Outputs 0 when address is within specified address area
P41 CS1	1	I/O Output	Port 41: I/O port (with pull-up resistor) Chip Select 1: Outputs 0 if address is within specified address area
P42 CS2	1	I/O Output	Port 42: I/O port (with pull-up resistor) Chip Select 2: Outputs 0 if address is within specified address area
P43 CS3	1	I/O Output	Port 43: I/O port (with pull-up resistor) Chip Select 3: Outputs 0 if address is within specified address area
P50~P57 AN0~AN7 ADTRG	8	Input Input Input	Port 5: Pin used to input port Analog input: Pin used to input to AD converter AD Trigger: Signal used to request start of AD converter (Shared with 53 pin)

Table 2.2.1 Pin names and functions (2/3)

Pin Name	Number of Pins	I/O	Functions
P60 SCK	1	I/O I/O	Port 60: I/O port Serial bus interface clock in SIO Mode
P61 SO SDA	1	I/O Output I/O	Port 61: I/O port Serial bus interface send data at SIO mode Serial bus interface send/recv data at I ² C bus mode Open-drain output mode by programmable
P62 SI SCL	1	I/O Input I/O	Port 62: I/O port Serial bus interface receive data at SIO mode Serial bus interface clock I/O data at I ² C bus mode Open-drain output mode by programmable
P63 INT0	1	I/O Input	Port 63: I/O port Interrupt Request Pin 0: Interrupt request pin with programmable level / rising edge / falling edge
P64 SCOUT	1	I/O Output	Port 64: I/O port System Clock Output: Outputs f _{FPH} or f _s clock.
P65	1	I/O	Port 65 I/O port
P66	1	I/O	Port 66 I/O port
P70 TA0IN	1	I/O Input	Port 70 I/O port 8-bit timer 0 input: Timer 0 input
P71 TA1OUT	1	I/O Output	Port 71 I/O port 8-bit timer 1 output: Timer 0 or Timer 1 output
P72 TA3OUT	1	I/O Output	Port 72 I/O port 8-bit 8-bit timer 3 output: Timer 2 or Timer 3 output
P73 TA4IN	1	I/O Input	Port 73: I/O port 8-bit timer 4 input: Timer 4 input
P74 TA5OUT	1	I/O Output	Port 74: I/O port 8-bit timer 5 output: Timer 4 or Timer 5 output
P75 TA7OUT	1	I/O Output	Port 75: I/O port 88-bit timer 7 output: Timer 6 or Timer 7 output
P80 TB0IN0 INT5	1	I/O Input Input	Port 80: I/O port 16-bit timer 0 input 0: 16-bit Timer 0 count / capture trigger input Interrupt Request Pin 5: Interrupt request pin with programmable rising edge / falling edge.
P81 TB0IN1 INT6	1	I/O Input Input	Port 81: I/O port 16-bit timer 0 input 1: 16-bit Timer 0 count / capture trigger input Interrupt Request Pin 6: Interrupt request on rising edge
P82 TB0OUT0	1	I/O Output	Port 82: I/O port 16-bit timer 0 output 0: 16-bit Timer 0 output
P83 TB0OUT1	1	I/O Output	Port 83: I/O port 16-bit timer 0 output 1: 16-bit Timer 0 output
P84 TB1IN0 INT7	1	I/O Input Input	Port 84: I/O port 16-bit timer 1 input 0: 16-bit Timer 1 count / capture trigger input Interrupt Request Pin 7: Interrupt request pin with programmable rising edge / falling edge.
P85 TB1IN1 INT8	1	I/O Input Input	Port 85: I/O port 16-bit timer 1 input 1: 16-bit Timer 1 count / capture trigger input Interrupt Request Pin 8: Interrupt request on rising edge
P86 TB1OUT0	1	I/O Output	Port 86: I/O port 16-bit timer 1 output 0: 16-bit Timer 1 output 16-bit
P87 TB1OUT1	1	I/O Output	Port 87: I/O port 16-bit timer 1 output 1: 16-bit Timer 1 output 16-bit 16-bit

Table 2.2.1 Pin names and functions (3/3)

Pin Name	Number of Pins	I/O	Functions
P90 TXD0	1	I/O Output	Port 90: I/O port Serial Send Data 0 (programmable open-drain)
P91 RXD0	1	I/O Input	Port 91: I/O port Serial Receive Data 0
P92 SCLK0 CTS0	1	I/O I/O Input	Port 92: I/O port Serial Clock I/O 0 Serial Data Send Enable 0 (Clear to Send)
P93 TXD1	1	I/O Output	Port 93: I/O port Serial Send Data 1 (programmable open-drain)
P94 RXD1	1	I/O Input	Port 94: I/O port (with pull-up resistor) Serial Receive Data 1
P95 SCLK1 CTS1	1	I/O I/O Input	Port 95: I/O port (with pull-up resistor) Serial Clock I/O 1 Serial Data Send Enable 1 (Clear to Send)
P96 XT1	1	I/O Input	Port 96: I/O port (open-drain output) Low-frequency oscillator connection pin
P97 XT2	1	I/O Output	Port 97: I/O port (open-drain output) Low-frequency oscillator connection pin
PA0~PA3 INT1~INT4	4	I/O Input	Ports A0 to A3: I/O ports Interrupt Request Pins 1 to 4: Interrupt request pins with programmable rising edge / falling edge.
PA4~PA7	4	I/O	Ports A4 to A7: I/O ports
ALE	1	Output	Address Latch Enable Can be disabled to reduce noise.
NMI	1	Input	Non-Maskable Interrupt Request Pin: Interrupt request pin with programmable falling edge or both edge.
AM0~1	2	Input	Operation mode: Fixed to AM1 = 1, AM0 = 1
EMU0	1	Output	Open pin
EMU1	1	Output	Open pin
RESET	1	Input	Reset: initializes TMP91FY42. (With pull-up resistor)
VREFH	1	Input	Pin for reference voltage input to AD converter (H)
VREFL	1	Input	Pin for reference voltage input to AD converter (L)
AVCC	1		Power supply pin for AD converter
AVSS	1		GND pin for AD converter (0 V)
X1/X2	2	I/O	High-frequency oscillator connection pins
DVCC	3		Power supply pins (All DVCC pins should be connected with the power supply pin.)
DVSS	3		GND pins (0 V) (All DVSS pins should be connected with the power supply pin.)

Note: An external DMA controller cannot access the device's built-in memory or built-in I/O devices using the BUSRQ and BUSAK signal.

3. Operation

This following describes block by block the functions and operation of the TMP91FY42.

Notes and restrictions for each book are outlined in 7 “Points of Note and Restrictions” at the end of this manual.

3.1 CPU

The TMP91FY42 incorporates a high-performance 16-bit CPU (The 900/L1 CPU). For CPU operation, see the “TLCS-900/L1 CPU”.

The following describe the unique function of the CPU used in the TMP91FY42; these functions are not covered in the TLCS-900/L1 CPU section.

3.1.1 Reset

When resetting the TMP91FY42 microcontroller, ensure that the power supply voltage is within the operating voltage range, and that the internal high-frequency oscillator has stabilized. Then hold the $\overline{\text{RESET}}$ input to low level for at least 10 system clocks (12 μ s at 27MHz).

Thus, when turn on the switch, be set to the power supply voltage is within the operating voltage range, and that the internal high-frequency oscillator has stabilized. Then hold the $\overline{\text{RESET}}$ input to low level at least for 10 system clocks.

Clock gear is initialized 1/16 mode by reset operation. It means that the system clock mode f_{SYS} is set to $f_c/32$ ($= f_c/16 \times 1/2$).

When the reset is accept, the CPU:

- Sets as follows the program counter (PC) in accordance with the reset vector stored at address FFFF00H to FFFF02H:
 - PC<7:0> ← Value at FFFF00H address
 - PC<15:8> ← Value at FFFF01H address
 - PC<23:16> ← Value at FFFF02H address
- Sets the stack pointer (XSP) to 100H.
- Sets bits <IFF2:0> of the status register (SR) to 111 (Sets the interrupt level mark register to level 7).
- Sets the <MAX> bit of the status register to 1 (MAX mode).
(Note: As this product does not support MIN mode, do not write a 0 to the <MAX>.)
- Clears bits <RFP2:0> of the status register to 000 (Sets the register bank to 0).

When reset is released, the CPU starts executing instructions in accordance with the program counter settings. CPU internal registers not mentioned above do not change when the reset is released.

When the reset is accepted, the CPU sets internal I/O, ports, and other pins as follows.

- Initializes the internal I/O registers.
- Sets the port pins, including the pins that also act as internal I/O, to general-purpose input or output port mode.
- Sets ALE pin to “High-Z”

Note: The CPU internal register (except to PC, SR, XSP) and internal RAM data do not change by resetting.

Figure 3.1.1 is a reset timing of the TMP91FY42.

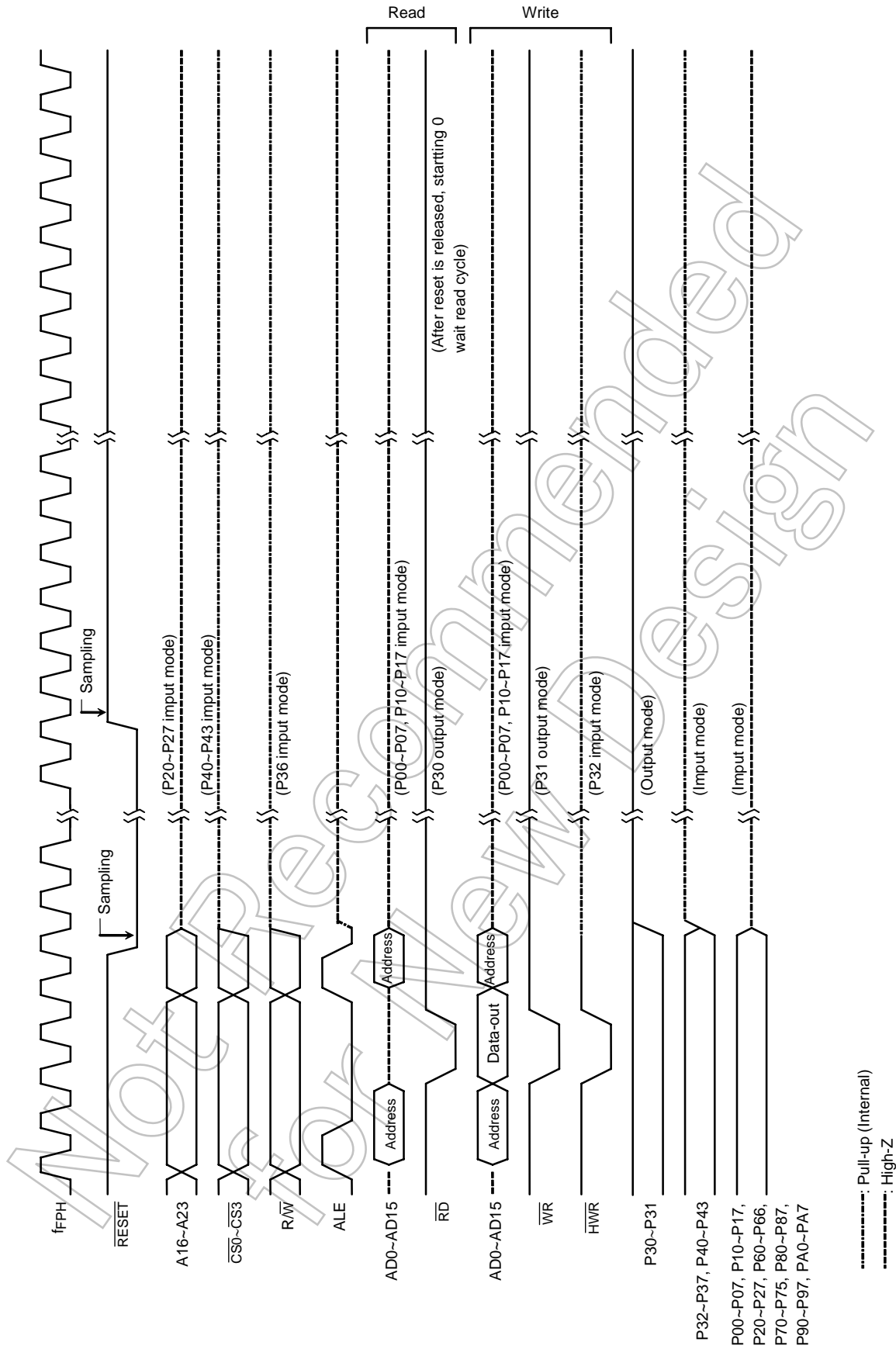



Figure 3.1.1 TMP91FY42 Reset Timing Example

3.1.2 Outline of Operation Modes

There are single-chip and single-boot modes. Which mode is selected depends on the device's pin state after a reset.

- Single-chip mode: The device normally operations in this mode. After a reset, the device starts executing the internal memory program.
- Single-boot mode: This mode is used to rewrite the internal flash memory by serial transfer (UART).
After a reset, internal boot program starts up, executing an on-board rewrite program.

Table 3.1.1 Operation Mode Setup Table

Operation Mode	Mode Setup Input Pin			
	RESET	BOOT (P37)	AM0	AM1
Single-chip mode		H	H	H
Single-boot mode		L		

Not Recommended for New Designs

3.2 Memory Map

Figure 3.2.1 is a memory map of the TMP91FY42.

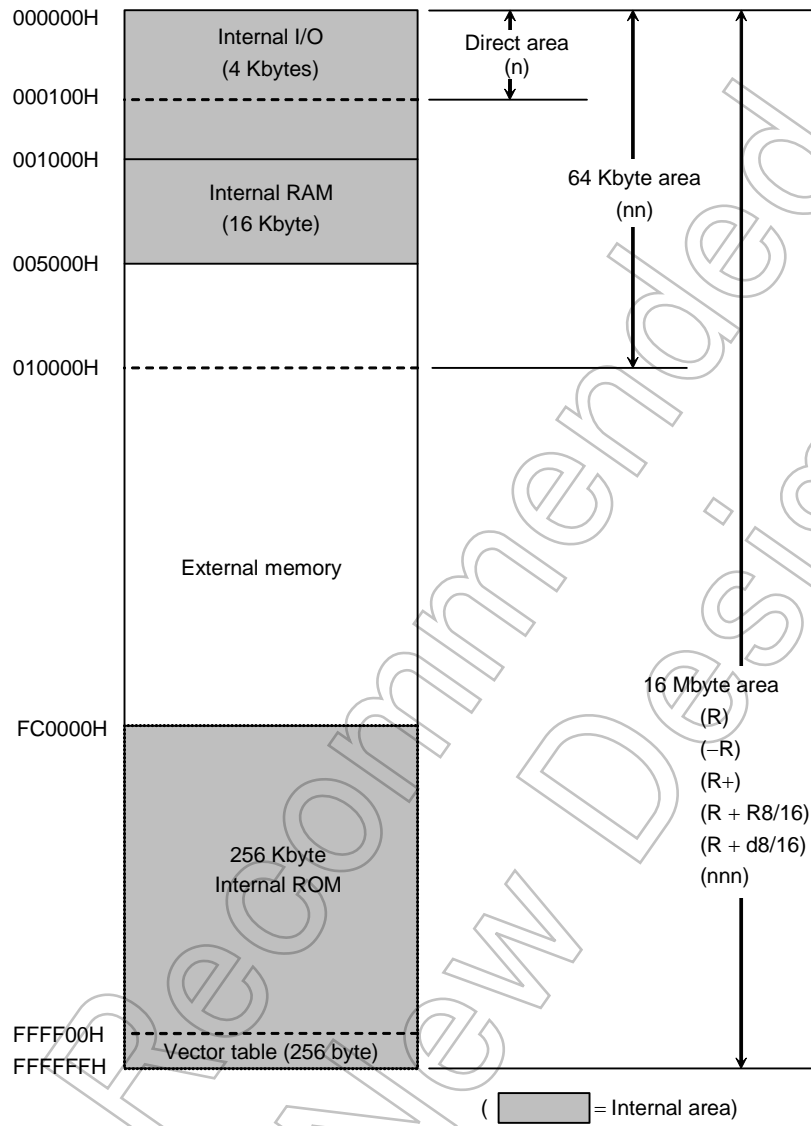

Figure 3.2.1 Memory Map

3.3 Triple Clock Function and Standby Function

TMP91FY42 contains (1) Clock gear, (2) Standby controller, and (3) Noise-reducing circuit. It is used for low-power, low-noise systems.

This chapter is organized as follows:

- 3.3.1 Block Diagram of System Clock
- 3.3.2 SFRs
- 3.3.3 System Clock Controller
- 3.3.4 Prescaler Clock Controller
- 3.3.5 Noise Reduction Circuits
- 3.3.6 Standby Controller

Not Recommended
for New Design

The clock operating modes are as follows: (a) Single clock mode (X1, X2 pins only), (b) Dual clock mode (X1, X2, XT1 and XT2 pins).

Figure 3.3.1 shows a transition figure.

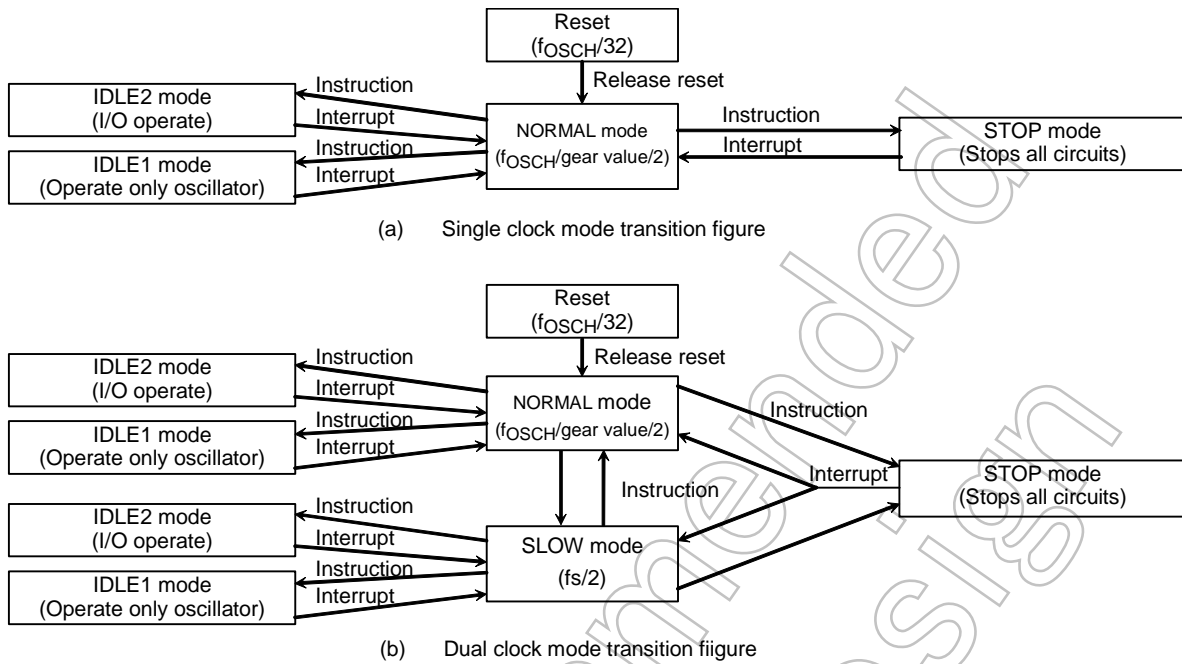

Figure 3.3.1 System Clock Block Diagram

The clock frequency input from the X1 and X2 pins is called f_c and the clock frequency input from the XT1 and XT2 pins is called f_s . The clock frequency selected by SYSCR1<SYSCK> is called the system clock f_{PPH} . The system clock f_{SYS} is defined as the divided clock of f_{PPH} , and one cycle of f_{SYS} is defined to as one state.

TMP91FY42 does not built-in Clock Doubler (DFM).

3.3.1 Block Diagram of System Clock

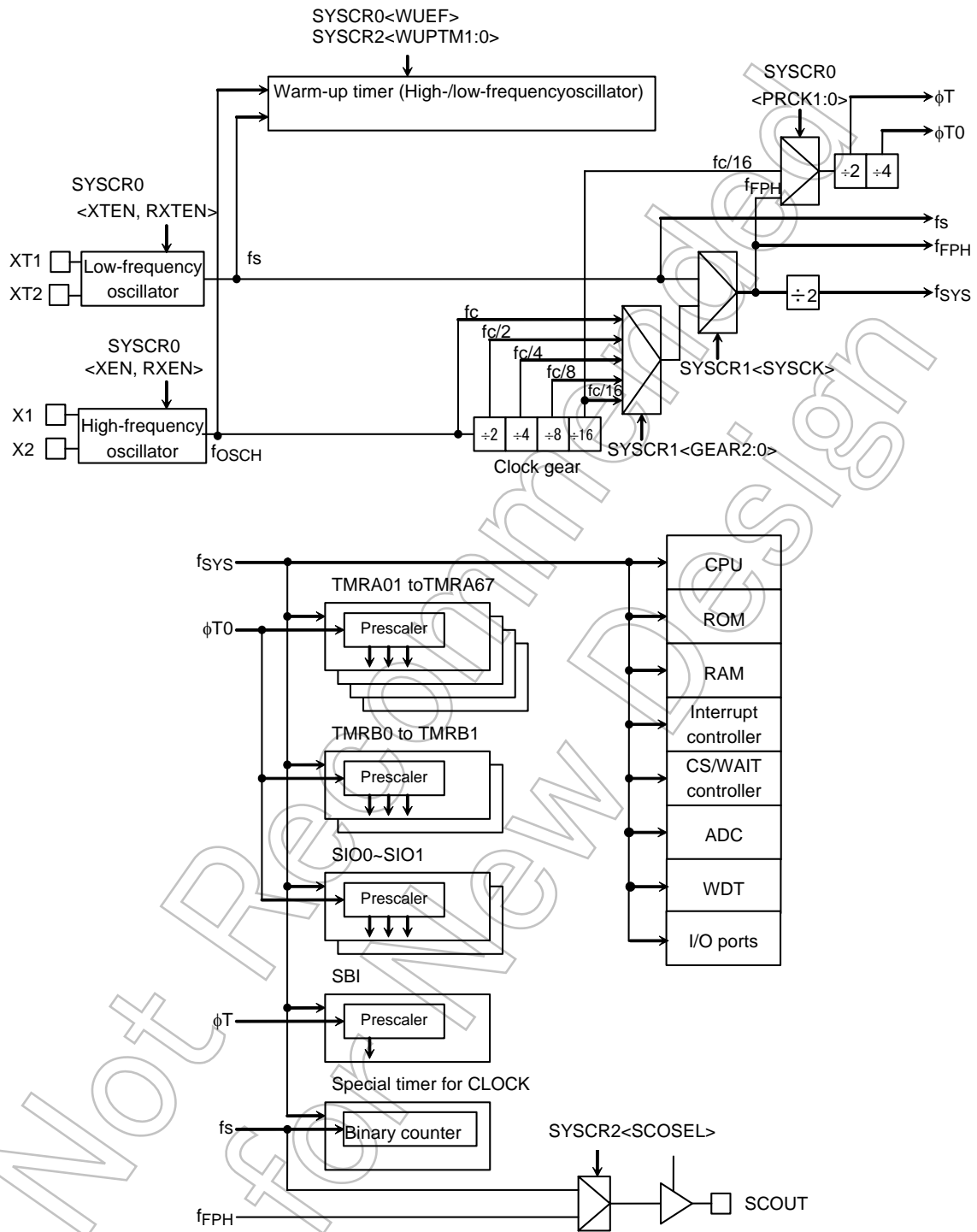

Figure 3.3.2 Block Diagram of System Clock

Note: TMP91FY42 does not built-in Clock Doubler (DFM).

3.3.2 SFRs

		7	6	5	4	3	2	1	0	
SYSCR0 (00E0H)	Bit symbol	XEN	XTEN	RXEN	RXTEN	RSYSCK	WUEF	PRCK1	PRCK0	
	Read/Write	R/W								
	After reset	1	1	1	0	0	0	0	0	
	Function	High-frequency oscillator (fc) 0: Stop 1: Oscillation	Low-frequency oscillator (fs) 0: Stop 1: Oscillation (Note 1)	High-frequency oscillator (fc) after release of STOP mode 0: Stop 1: Oscillation	Low-frequency oscillator (fs) after release of STOP mode 0: Stop 1: Oscillation	Selects clock after release of STOP mode 0: fc 1: fs	Warm-up timer 0: Write don't care 1: Write start timer 0: Read end warm up 1: Read do not end warm up	Select prescaler clock 00: f _{FPH} (Note 2) 01: Reserved 10: fc/16 11: Reserved		
SYSCR1 (00E1H)	Bit symbol					SYSCK	GEAR2	GEAR1	GEAR0	
	Read/Write	R/W								
	After reset					0	1	0	0	
	Function					Select system clock 0: fc 1: fs	Select gear value of high frequency (fc) 000: fc 001: fc/2 010: fc/4 011: fc/8 100: fc/16 101: (Reserved) 110: (Reserved) 111: (Reserved)			
SYSCR2 (00E2H)	Bit symbol		SCOSEL	WUPTM1	WUPTM0	HALTM1	HALTM0		DRVE	
	Read/Write		R/W							R/W
	After reset		0	1	0	1	1		0	
	Function		Selects SCOUT 0: fs 1: f _{FPH}	Warm-up timer 00: Reserved 01: 2 ⁸ /inputted frequency 10: 2 ¹⁴ /inputted frequency 11: 2 ¹⁶ /inputted frequency		HALT mode 00: Reserved 01: STOP mode 10: IDLE1 mode 11: IDLE2 mode			Pin state control in STOP/IDLE1 mode 0: I/O off 1: Remains the state before halt	

Note 1: SYSCR1<bit7:4>, SYSCR2<bit7,1> are read as undefined value.

Note 2: In case of using built-in SBI circuit, it must set SYSCR0<PRCK1:0> to 00.

Figure 3.3.3 SFR for System Clock

	7	6	5	4	3	2	1	0
DFMCR0 (00E8H)	ACT1	ACT10	DLUPFG	DLUPTM				
Read/Write	R/W		R	R/W				
After reset	0	0	0	0				
Function	Always write "0"							

	7	6	5	4	3	2	1	0
DFMCR1 (00E9H)	-	-	-	-	-	-	-	-
Read/Write	R/W							
After reset	0	0	0	1	0	0	1	1
Function	Don't access this register							

Figure 3.3.4 SFR for DFM

Note: TMP91FY42 does not built-in Clock Doubler (DFM).

	7	6	5	4	3	2	1	0
EMCCR0 (00E3H)	PROTECT	-	-	-	ALEEN	EXTIN	DRVOSCH	DRVOSCL
Read/Write	R	R/W						
After reset	0	0	1	0	0	0	1	1
Function	Protect flag 0: OFF 1: ON	Always write "0"	Always write "1"	Always write "0"	0: ALE output disable 1: ALE output enable	1: fc external clock	fc oscillator driver ability 1: Normal 0: Weak	fs oscillator driver ability 1: Normal 0: Weak
EMCCR1 (00E4H)	Bit symbol	Writing 1FH turns protections off. Writing any value other than 1FH turns protection on.						
	Read/Write							
	After reset							
	Function							

Note1: When restarting the oscillator from the stop oscillation state (e.g. restarting the oscillator in STOP mode), set EMCCR0<DRVOSCH>, <DRVOSCL>="1"..

Figure 3.3.5 SFR for Noise Reducing

3.3.3 System Clock Controller

The system clock controller generates the system clock signal (f_{SYS}) for the CPU core and internal I/O. It contains two oscillation circuits and a clock gear circuit for high-frequency (f_c) operation. The register SYSCR1<SYSCK> changes the system clock to either f_c or f_s , SYSCR0<XEN> and SYSCR0<XTEN> control enabling and disabling of each oscillator, and SYSCR1<GEAR0:2> sets the high-frequency clock gear to either 1, 2, 4, 8 or 16 (f_c , $f_c/2$, $f_c/4$, $f_c/8$ or $f_c/16$). These functions can reduce the power consumption of the equipment in which the device is installed.

The combination of settings <XEN> = 1, <XTEN> = 0, <SYSCK> = 0 and <GEAR0:2> = 100 will cause the system clock (f_{SYS}) to be set to $f_c/32$ ($f_c/16 \times 1/2$) after a reset.

For example, f_{SYS} is set to 0.84 MHz when the 27-MHz oscillator is connected to the X1 and X2 pins.

(1) Switching from NORMAL mode to SLOW mode

When the resonator is connected to the X1 and X2 pins, or to the XT1 and XT2 pins, the warm-up timer can be used to change the operation frequency after stable oscillation has been attained.

The warm-up time can be selected using SYSCR2<WUPTM0:1>.

This warm-up timer can be programmed to start and stop as shown in the following examples 1 and 2.

Table 3.3.1 shows the warm-up times.

Note 1: When using an oscillator (Other than a resonator) with stable oscillation, a warm-up timer is not needed.

Note 2: The warm-up timer is operated by an oscillation clock. Hence, there may be some variation in warm-up time.

Note 2: Note on using low-frequency oscillation circuit

To connect the low-frequency resonator to port 96, 97, it is necessary to set the following to reduce the power consumption.

(connecting with resonators)

P9CR<P96C:97C> = 11, P9<P96:97> = 00

(connection with oscillators)

P9CR<P96C:97C> = 11, P9<P96:97> = 10

Table 3.3.1 Warm-up Times

Warm-up Time SYSCR2 <WUPTM1:0>	Change to NORMAL Mode	Change to SLOW Mode
01 ($2^8/\text{frequency}$)	9.0 [μs]	7.8 [ms]
10 ($2^{14}/\text{frequency}$)	0.607 [ms]	500 [ms]
11 ($2^{16}/\text{frequency}$)	2.427 [ms]	2000 [ms]

at $f_{OSCH} = 27 \text{ MHz}$,
 $f_s = 32.768 \text{ kHz}$

Example 1: Setting the clock

Changing from high frequency (fc) to low frequency (fs).

SYSCR0	EQU	00E0H		
SYSCR1	EQU	00E1H		
SYSCR2	EQU	00E2H		
	LD	(SYSCR2), -X11--X-B	:	Sets warm-up time to $2^{16}/f_s$.
	SET	6, (SYSCR0)	:	Enables low-frequency oscillation.
	SET	2, (SYSCR0)	:	Clears and starts warm-up timer.
WUP:	BIT	2, (SYSCR0)	:	} Detects stopping of warm-up timer.
	JR	NZ, WUP	:	
	SET	3, (SYSCR1)	:	Changes f_{SYS} from f_c to f_s .
	RES	7, (SYSCR0)	:	Disables high-frequency oscillation.

X: Don't care, -: No change

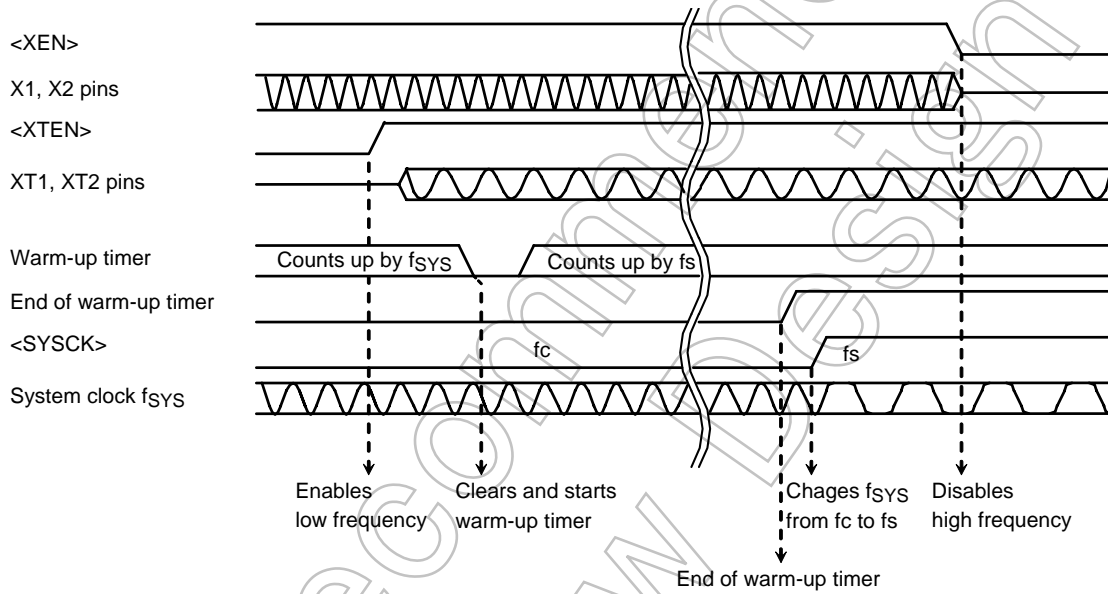

Not Recommended for New

Example 2: Setting the clock
 Changing from low frequency (f_s) to high frequency (f_c).

SYSCR0	EQU	00E0H		
SYSCR1	EQU	00E1H		
SYSCR2	EQU	00E2H		
	LD	(SYSCR2), -X10----	-B	; Sets warm-up time to $2^{14}/f_c$.
	SET	7, (SYSCR0)		; Enables high-frequency oscillation.
	SET	2, (SYSCR0)		; Clears and starts warm-up timer.
WUP:	BIT	2, (SYSCR0)		; } Detects stopping of warm-up timer.
	JR	NZ, WUP		; }
	RES	3, (SYSCR1)		; Changes f_{SYS} from f_s to f_c .
	RES	6, (SYSCR0)		; Disables low-frequency oscillation.

X: Don't care, -: No change

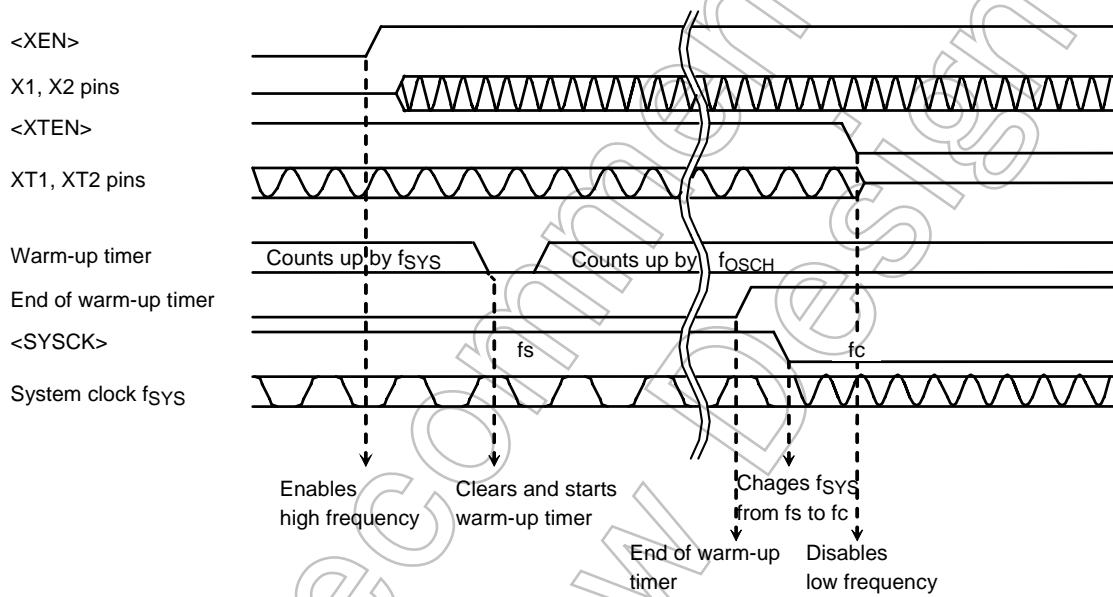

(2) Clock gear controller

When the high-frequency clock f_c is selected by setting $\text{SYSCR1}\langle\text{SYSCK}\rangle = 0$, f_{FPH} is set according to the contents of the clock gear select register $\text{SYSCR1}\langle\text{GEAR2:0}\rangle$ to either f_c , $f_c/2$, $f_c/4$, $f_c/8$ or $f_c/16$. Using the clock gear to select a lower value of f_{FPH} reduces power consumption.

Example 3: Changing to a high-frequency gear
 SYSCR1 EQU 00E1H
 LD (SYSCR1), XXXX0000B ; Changes f_{SYS} to $f_c/2$.

X: Don't care

(High-speed clock gear changing)

To change the clock gear, write the register value to the $\text{SYSCR1}\langle\text{GEAR2:0}\rangle$ register. It is necessary the warm-up time until changing after writing the register value.

There is the possibility that the instruction next to the clock gear changing instruction is executed by the clock gear before changing. To execute the instruction next to the clock gear switching instruction by the clock gear after changing, input the dummy instruction as follows (Instruction to execute the write cycle).

(Example)
 SYSCR1 EQU 00E1H
 LD (SYSCR1), XXXX0001B ; Changes f_{SYS} to $f_c/4$.
 LD (DUMMY), 00H ; Dummy instruction.

Instruction to be executed after clock gear has changed.

(3) Internal colck pin output function

P64/SCOUT pin outputs the internal clocks f_{FPH} or f_s .

The port 6 control register $\text{P6CR}\langle\text{P64C}\rangle = 1$, $\text{P6FC}\langle\text{P64F}\rangle = 1$ specifies the SCOUT output pin. The selection of output clock is set by $\text{SYSCR2}\langle\text{SCOSEL}\rangle$.

Table 3.3.2 shows pin states in their respective operation modes which is under condition that P64/SCOUT pin is specifies as SCOUT output.

Table 3.3.2 SCOUT Pin States in the Operation Modes

Operation Mode SCOUT	NORMAL, SLOW	HALT Mode		
		IDLE2	IDLE1	STOP
$\langle\text{SCOSEL}\rangle = "0"$		Outputs f_s clock		Fixed to "0" or "1"
$\langle\text{SCOSEL}\rangle = "1"$	Output f_{FPH} clock			

3.3.4 Prescaler Clock Controller

For the internal I/O (TMRA01 to TMRA67, TMRB0 to TMRB1, SIO0 to SIO1, SBI) there is a prescaler which can divide the clock.

The ϕ_T clock input to the prescaler is either the clock f_{PPH} divided by 2 or the clock $f_c/16$ divided by 2. The setting of the SYSCR0<PRCK0:1> register determines which clock signal is input. When it's used internal SBI circuit, <PRCK1:0> register must be set to 00.

3.3.5 Noise Reduction Circuits

Noise reduction circuits are built in, allowing implementation of the following features.

- (1) Reduced drivability for high-frequency oscillator
- (2) Reduced drivability for low-frequency oscillator
- (3) Single drive for high-frequency oscillator]
- (4) Disables Output for ALE-pin
- (4) Runaway provision with SFR protection register

The above functions are performed by making the appropriate settings in the EMCCR0 to EMCCR1 registers.

- (1) Reduced drivability for high-frequency oscillator

(Purpose)

Reduces noise and power for oscillator when a resonator is used.

(Block diagram)

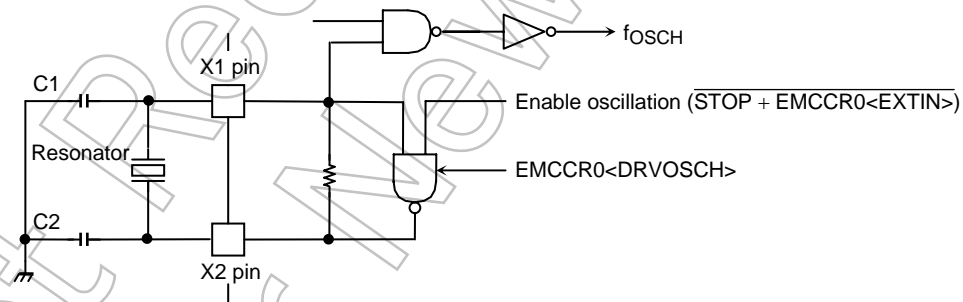

(Setting method)

The drivability of the oscillator is reduced by writing 0 to EMCCR0<DRVOSCH> register. By reset, <DRVOSCH> is initialized to 1 and the oscillator starts oscillation by normal drivability when the power supply is on. The case of $V_{CC} \leq 2.7$ V, it is impossible to use selecting function of drivability of High-frequency oscillator.

Do not write "0" to EMCCR0<DRVOSCH>.

(2) Reduced drivability for low-frequency oscillator

(Purpose)

Reduces noise and power for oscillator when a resonator is used.

(Block diagram)

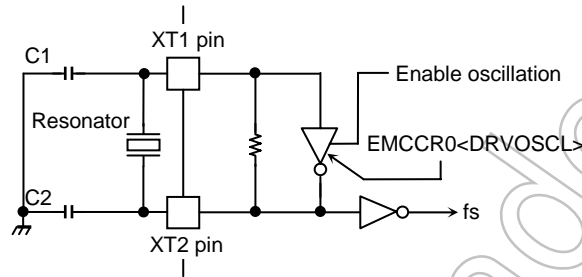

(Setting method)

The drivability of the oscillator is reduced by writing 0 to the EMCCR0<DRVOSCL> register. By reset, <DRVOSCL> is initialized to 1.

(3) Single drive for high-frequency oscillator

(Purpose)

Not need twin-drive and protect mistake operation by inputted noise to X2 pin when the external oscillator is used.

(Block diagram)

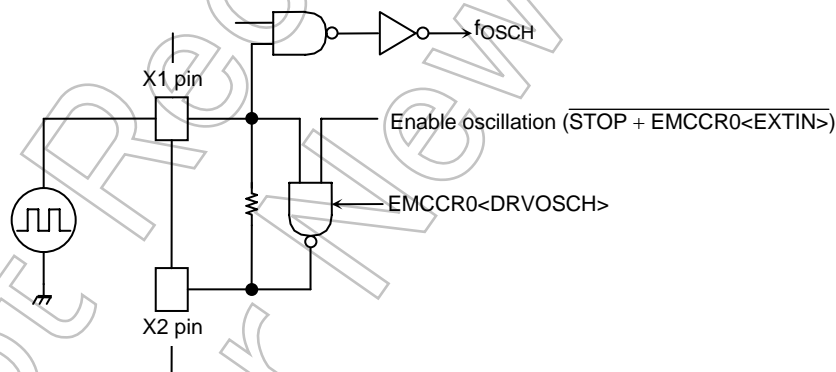

(Setting method)

The oscillator is disabled and starts operation as buffer by writing 1 to EMCCR0<EXTIN> register. X2 pin is always outputted 1.

By reset, <EXTIN> is initialized to 0.

Note: Do not write EMCCR0<EXTIN> = "1" when using external resonator.

(4) Disables Output for ALE-pin

(Purpose)

Disables output ALE pulse for reducing noise when CPU does not access to external area.

(Block diagram)

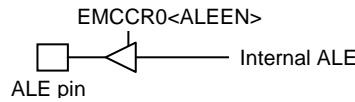

(Setting method)

ALE pin is set to high-impedance by writing “0” to EMCCR0<ALEEN> register. By reset, <ALEEN> is initialized to “0”. Write “1” to <ALEEN> before access when CPU will access to external area.

(4) Runaway provision with SFR protection registers

(Purpose)

Provision in runaway of program by noise mixing.

Write operation to specified SFR is prohibited so that provision program in runaway prevents that it is in the state which is fetch impossibility by stopping of clock, memory control register (CS/WAIT controller) is changed.

Specified SFR list

- | |
|---|
| <p>1. CS/WAIT controller
 B0CS, B1CS, B2CS, B3CS, BEXCS,
 MSAR0, MSAR1, MSAR2, MSAR3,
 MAMR0, MAMR1, MAMR2, MAMR3</p> <p>2. Clock gear (Only EMCCR1 is available to write).
 SYSCR0, SYSCR1, SYSCR2, EMCCR0</p> <p>4. (DFM)
 DFMCRO</p> |
|---|

(Block diagram)

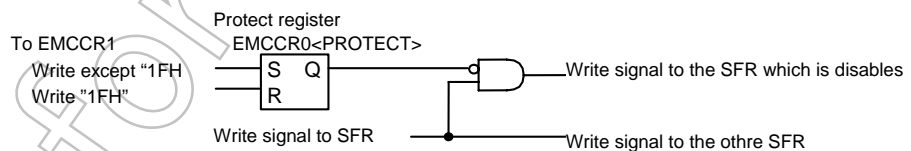

(Setting method)

The protect-status is ON by writing except “1FH” Codes to EMCCR1 register, and CPU is disabled to write-operation to the specific-SFR.

The protect-status is OFF by writing “1FH” code to EMCCR1. The protect-status is set to EMCCR0<PROTECT>register.

It is initialized to OFF by resetting.

3.3.6 Standby Controller

(1) HALT modes

When the HALT instruction is executed, the operating mode switches to IDLE2, IDLE1 or STOP mode, depending on the contents of the SYSCR2<HALTM1:0> register.

The subsequent actions performed in each mode are as follows:

- a. IDLE2: Only the CPU halts.

The internal I/O is available to select operation during IDLE2 mode by setting the following register.

Table 3.3.3 shows the registers of setting operation during IDLE2 mode.

Table 3.3.3 SFR Setting Operation during IDLE2 Mode

Internal I/O	SFR
TMRA01	TA01RUN<I2TA01>
TMRA23	TA23RUN<I2TA23>
TMRA45	TA45RUN<I2TA45>
TMRA67	TA67RUN<I2TA67>
TMRB0	TB0RUN<I2TB0>
TMRB1	TB1RUN<I2TB1>
SIO0	SC0MOD1<I2S0>
SIO1	SC1MOD1<I2S1>
SBI	SBI0BR0<I2SBI0>
AD converter	ADMOD1<I2AD>
WDT	WDMOD<I2WDT>

- b. IDLE1: Only the oscillator and the Special timer for CLOCK continue to operate.

- c. STOP: All internal circuits stop operating.

The operation of each of the different HALT modes is described in Table 3.3.4.

Table 3.3.4 I/O Operation during HALT Modes

HALT Mode		IDLE2	IDLE1	STOP	
SYSCR2<HALTM1:0>		11	10	01	
Block	CPU	Stop			
	I/O ports	Keep the state when the HALT instruction was executed.		See Table 3.3.7, Table 3.3.8	
	TMRA01~TMRA67, TMRB0~TMRB1	Available to select operation block			Stop
	SIO0~SIO1, SBI				
	AD converter				
	WDT				
	Special timer for CLOCK	Operational available			
	Interrupt controller	Operate			

(2) How to release the HALT mode

These halt states can be released by resetting or requesting an interrupt. The halt release sources are determined by the combination between the states of interrupt mask register <IFF2:0> and the HALT modes. The details for releasing the halt status are shown in Table 3.3.5.

Released by requesting an interrupt

The operating released from the HALT mode depends on the interrupt enabled status. When the interrupt request level set before executing the halt instruction exceeds the value of interrupt mask register, the interrupt due to the source is processed after releasing the HALT mode, and CPU status executing an instruction that follows the halt instruction. When the interrupt request level set before executing the halt instruction is less than the value of the interrupt mask register, releasing the HALT mode is not executed (in non-maskable interrupts, interrupt processing is processed after releasing the HALT mode regardless of the value of the mask register). However only for INT0 to INT4 and INTRTC, even if the interrupt request level set before executing the halt instruction is less than the value of the interrupt mask register, releasing the the HALT mode is executed. In this case, interrupt processing, and CPU starts executing the instruction next to the HALT instruction, but the interrupt request flag is held at 1.

Note: Usually, interrupts can release all halt status. However, the interrupts ($\overline{\text{NMI}}$, INT0 to INT4, INTRTC) which can release the HALT mode may not be able to do so if they are input during the period CPU is shifting to the HALT mode (for about 5 clocks of f_{FPH}) with IDLE1 or STOP mode (IDLE2 is not applicable to this case). (In this case, an interrupt request is kept on hold internally.) If another interrupt is generated after it has shifted to the HALT mode completely, halt status can be released without difficulty. The priority of this interrupt is compared with that of the interrupt kept on hold internally, and the interrupt with higher priority is handled first followed by the other interrupt.

- Releasing by resetting

Releasing all halt status is executed by resetting.

When the stop mode is released by reset, it is necessary enough resetting time (See Table 3.3.6) to set the operation of the oscillator to be stable.

When releasing the HALT mode by resetting, the internal RAM data keeps the state before the HALT instruction is executed. However the other settings contents are initialized. (Releasing due to interrupts keeps the state before the HALT instruction is executed.)

Table 3.3.5 Source of Halt State Clearance and Halt Clearance Operation

Status of Received Interrupt		Interrupt Enabled (Interrupt level) ≥ (Interrupt mask)			Interrupt Disabled (Interrupt level) < (Interrupt mask)			
		HALT mode	IDLE2	IDLE1	STOP	IDLE2	IDLE1	STOP
Source of halt state clearance	Interrupt	NMI	◆	◆	◆*1	—	—	—
		INTWD	◆	×	×	—	—	—
		INT0~INT4 (Note 1)	◆	◆	◆*1	○	○	○*1
		INTRTC	◆	◆	×	○	○	×
		INT5~INT8	◆ (Note2)	×	×	×	×	×
		INTTA0~INTTA7	◆	×	×	×	×	×
		INTTB00, INTTB01, INTTB10, INTTB11, INTTBOF0, INTTBOF1	◆	×	×	×	×	×
		INTRX0~INTRX1, INTTX0~INTTX1	◆	×	×	×	×	×
		INTSBI	◆	×	×	×	×	×
		INTAD	◆	×	×	×	×	×
		RESET	Initialize LSI.					

- ◆: After clearing the HALT mode, CPU starts interrupt processing.
- : After clearing the HALT mode, CPU resumes executing starting from instruction following the HALT instruction.
- ×: It can not be used to release the HALT mode.
- : The priority level (Interrupt request level) of non-maskable interrupts is fixed to 7, the highest priority level. There is not this combination type.
- *1: Releasing the HALT mode is executed after passing the warm-up time.

Note1: When the HALT mode is cleared by an INT0 interrupt of the level mode in the interrupt enabled status, hold level H until starting interrupt processing. If level L is set before holding level L, interrupt processing is correctly started.

Note2: When the external interrupts INT5 to INT8 are used during IDLE2 mode, set to 1 for TB0RUN<I2TB0> and TB1RUN<I2TB1>.

(Example releasing IDLE1 mode)

An INT0 interrupt clears the halt state when the device is in IDLE1 mode.

```

Address
8200H   LD   (P6FC), 08H           ; Sets P63 to INT0.
8203H   LD   (IIMC), 00H          ; Selects INT0 interrupt rising edge.
8206H   LD   (INTE0AD), 06H       ; Sets INT0 interrupt level to 6.
8209H   EI   5                    ; Sets interrupt level to 5 for CPU.
820BH   LD   (SYSCR2), 88H        ; Sets HALT mode to IDLE1 mode.
820EH   HALT                      ; Halts CPU.
    
```



(3) Operation

a. IDLE2 mode

In IDLE2 mode only specific internal I/O operations, as designated by the IDLE2 setting register, can take place. Instruction execution by the CPU stops.

Figure 3.3.6 illustrates an example of the timing for clearance of the IDLE2 mode halt state by an interrupt.

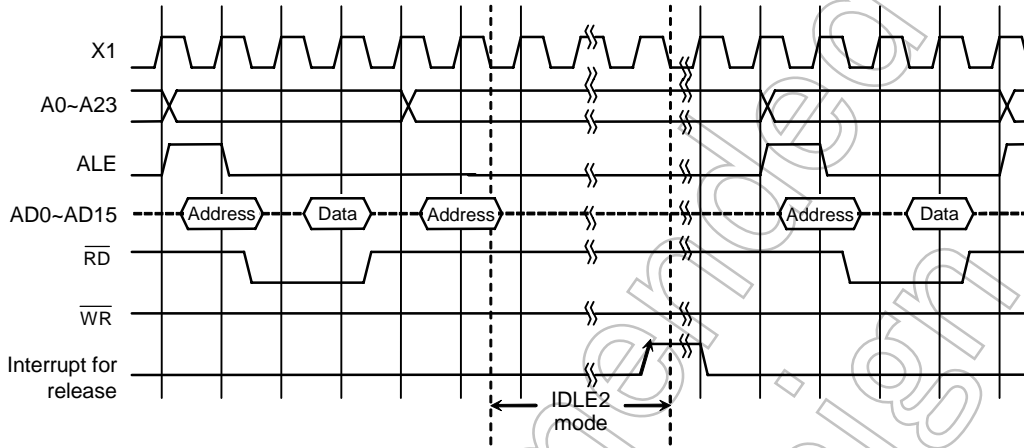

Figure 3.3.6 Timing Chart for IDLE2 Mode Halt State Cleared by Interrupt

b. IDLE1 mode

In IDLE1 mode, only the internal oscillator and the Special timer for CLOCK continue to operate. The system clock in the MCU stops.

In the halt state, the interrupt request is sampled asynchronously with the system clock; however, clearance of the halt state (e.g., restart of operation) is synchronous with it.

Figure 3.3.7 illustrates the timing for clearance of the IDLE1 mode halt state by an interrupt.

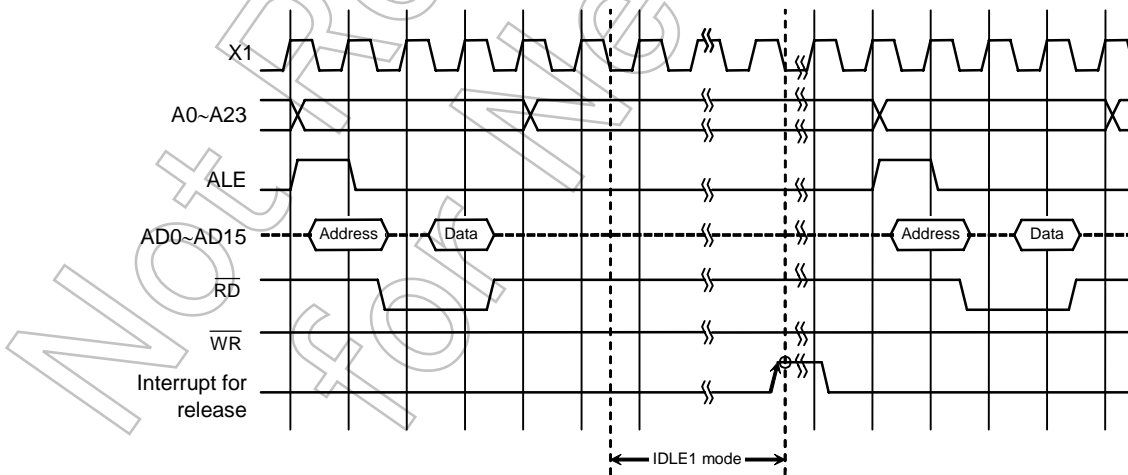

Figure 3.3.7 Timing Chart for IDLE1 Mode Halt State Cleared by Interrupt

c. STOP mode

When STOP mode is selected, all internal circuits stop, including the internal oscillator pin status in STOP mode depends on the settings in the SYSCR2<DRVE> register. Table 3.3.7, Table 3.3.8 summarizes the state of these pins in STOP mode.

After STOP mode has been cleared system clock output starts when the warm-up time has elapsed, in order to allow oscillation to stabilize. After STOP mode has been cleared, either NORMAL mode or SLOW mode can be selected using the SYSCR0<RSYSCK> register. Therefore, <RSYSCK>, <RXEN> and <RXTEN> must be set see the sample warm-up times in Table 3.3.6.

Figure 3.3.8 illustrates the timing for clearance of the STOP mode halt state by an interrupt.

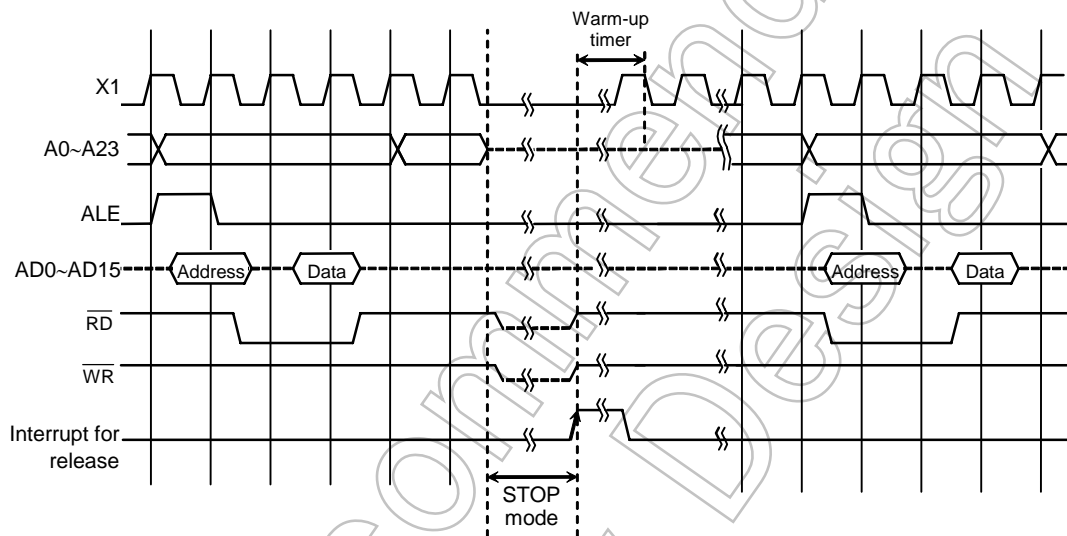

Figure 3.3.8 Timing Chart for STOP Mode Halt State Cleared by Interrupt

Table 3.3.6 Sample Warm-up Times after Clearance of STOP Mode

at f_{OSCH} = 27 MHz, f_s = 32.768 kHz

SYSCR0 <RSYSCK>	SYSCR2<WUPTM1:0>		
	01 (2 ⁸)	10 (2 ¹⁴)	11 (2 ¹⁶)
0 (fc)	9.0 μs	0.607 ms	2.427 ms
1 (fs)	7.8 ms	500 ms	2000 ms

- (Setting example)
- The STOP mode is entered when the low frequency operates, and high frequency operates after releasing due to NMI.

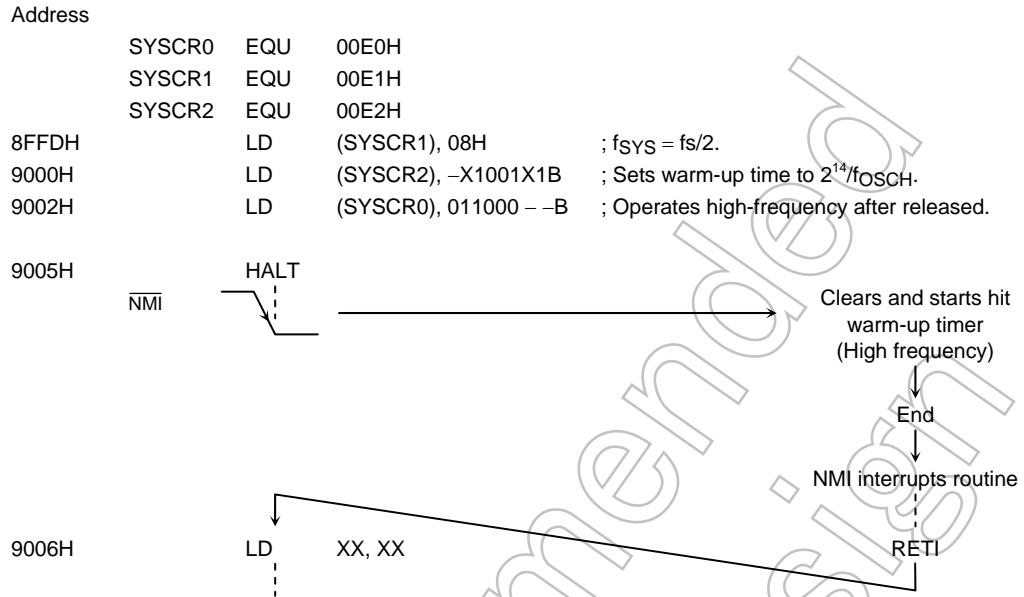

- -: No change

Not Recommended for New Design

Table 3.3.7 Input buffer state table

Port Name	Input Function Name	Input Buffer State								
		During Reset	When the CPU is operating		In HALT mode (IDLE2)		In HALT mode (STOP)			
			When Used as function Pin	When Used as Input Port	When Used as function Pin	When Used as Input Port	<DRVE>=1		<DRVE>=0	
						When Used as function Pin	When Used as Input Port	When Used as function Pin	When Used as Input Port	
P00-07	AD0-AD7	OFF	ON upon external read	ON	OFF	OFF	OFF	OFF	OFF	
P10-17	AD8-AD15				-		-			
P20-27	-				-		-			
P32	-				-		-			
P33	WAIT	ON	ON	OFF	ON	OFF	OFF	OFF	OFF	
P34	BUSRQ			ON		ON				
P35-P37	-			-		ON				
P40-43	-			-		-				
P50-52, P54-57	-	OFF	ON upon port read	-	OFF	OFF	OFF	ON	OFF	
P53	ADTRG			-		ON				
P60	SCK	ON	ON	ON	ON	ON	OFF	ON	ON	
P61	SDA			ON		ON				
P62	SCL, SI			ON		ON				
P63	INT0			ON		ON				
P64-66	-	ON	ON	-	ON	-	-	-	OFF	
P70	TA0IN			ON		ON				
P73	TA4IN			ON		ON				
P71-72, P74-75	-			-		-				
P80	INT5, TB0IN0			ON		ON				
P81	INT6, TB0IN1			ON		ON				
P84	INT7, TB1IN0			ON		ON				
P85	INT8, TB1IN1			ON		ON				
P82-83, P86-87	-			-		-				
P90, P93	-			-		-				
P91	RXD0	ON	ON	ON	ON	ON	OFF	OFF	OFF	
P92	SCLK0, CTS0			ON		ON				
P94	RXD1			ON		ON				
P95	SCLK1, CTS1			ON		ON				
P96	XT1	For oscillator	OFF	OFF	OFF	OFF	OFF	OFF	OFF	
		For port	ON	OFF	OFF	ON	ON	ON		
P97	-	OFF	ON	-	OFF	-	-	-	ON	
PA0	INT1			ON		ON				
PA1	INT2			ON		ON				
PA2	INT3			ON		ON				
PA3	INT4			ON		ON				
PA4-A7	-	-	-							
NMI, RESET, AM0, AM1	-	ON	ON	-	ON	-	ON	ON	-	
X1	-	-	-	-	-	OFF	-	OFF	-	

ON: The buffer is always turned on. A current flow the input buffer if the input pin is not driven.

OFF: The buffer is always turned off.

-: No applicable

*1: Port having a pull-up/pull-down resistor.

*2: AIN input does not cause a current to flow through the buffer.

Table 3.3.8 Output buffer state table

Port Name	Output Function Name	Input Buffer State								
		During Reset	When the CPU is operating		In HALT mode (IDLE2)		In HALT mode (STOP)			
			When Used as function Pin	When Used as output Port	When Used as function Pin	When Used as output Port	<DRVE>=1		<DRVE>=0	
							When Used as function Pin	When Used as output Port	When Used as function Pin	When Used as output Port
P00-07	AD0-AD7	OFF	ON upon external write		OFF		OFF		OFF	
P10-17	AD8-AD15									
	A8-A15									
P20-27	A0-A7	ON	ON		ON		ON		OFF	
	A16-A23									
P30	RD									
P31	WR	ON							OFF	
P32	HWR									
P33-34,37	-			-		-		-		
P35	BUSAK	OFF							OFF	
P36	R/W									
P40	CS0		ON		ON		ON			OFF
P41	CS1									
P42	CS2									
P43	CS3									
P60	SCK									
P61	SDA,SO			ON		ON		ON		
P62	SCL									
P63,65-66	-			-		-		-		
P64	SCOUT	OFF	ON		ON		ON		OFF	
P70,73	-			-		-		-		
P71	TA1OUT									
P72	TA3OUT		ON		ON		ON		OFF	
P74	TA5OUT									
P75	TA7OUT									
P80-81, P84-85	-			-		-		-		
P82	TB0OUT0									
P83	TB0OUT1									
P86	TB1OUT0		ON		ON		ON		OFF	
P87	TB1OUT1									
P90	TXD0									
P91,94	-		-		-		-		OFF	
P92	SCLK0									
P93	TXD1	ON		ON		ON		OFF		
P95	SCLK1									
P96	-	ON	-		-		-		-	
P97	XT2	- For oscillator	OFF	ON	OFF	ON	OFF	OFF	OFF	OFF
		- For port	ON	OFF	ON	OFF	ON	ON	ON	ON
PA0-A7	-	OFF	-		-		-		-	
ALE	-	OFF	-		-		ON		ON	
X2	-	ON	ON	-	ON	-	Output "H" level	-	Output "H" level	-

*1
*1
*1
*1
*1
*1
*1

ON: The buffer is always turned on. When the bus is released, however, output buffers for some pins are turned off. *1: Port having a pull-up/pull-down resistor

OFF: The buffer is always turned off.

-: Not applicable

3.4 Interrupts

Interrupts are controlled by the CPU interrupt mask register SR<IFF2:0> and by the built-in interrupt controller.

The TMP91FY42 has a total of 45 interrupts divided into the following five types:

- Interrupts generated by CPU: 9 sources
(Software interrupts, illegal instruction interrupt)
- Internal interrupts: 26 sources
- Interrupts on external pins ($\overline{\text{NMI}}$ and INT0 to INT8): 10 sources

A (Fixed) individual interrupt vector number is assigned to each interrupt.

One of six (Variable) priority level can be assigned to each maskable interrupt.

The priority level of non-maskable interrupts are fixed at 7 as the highest level.

When an interrupt is generated, the interrupt controller sends the priority of that interrupt to the CPU. If multiple interrupts are generated simultaneously, the interrupt controller sends the interrupt with the highest priority to the CPU. (The highest priority is level 7 using for non-maskable interrupts.)

The CPU compares the priority level of the interrupt with the value of the CPU interrupt mask register <IFF2:0>. If the priority level of the interrupt is higher than the value of the interrupt mask register, the CPU accepts the interrupt.

The interrupt mask register <IFF2:0> value can be updated using the value of the EI instruction (EI num sets <IFF2:0> data to num).

For example, specifying EI 3 enables the maskable interrupts which priority level set in the interrupt controller is 3 or higher, and also non-maskable interrupts.

Operationally, the DI instruction (<IFF2:0> = 7) is identical to the EI7 instruction. DI instruction is used to disable maskable interrupts because of the priority level of maskable interrupts is 1 to 6. The EI instruction is valid immediately after execution.

In addition to the above general-purpose interrupt processing mode, TLCS-900/L1 has a micro DMA interrupt processing mode as well. The CPU can transfer the data (1/2/4 bytes) automatically in micro DMA mode, therefore this mode is used for speed-up interrupt processing, such as transferring data to the internal or external peripheral I/O. Moreover, TMP91FY42 has software start function for micro DMA processing request by the software not by the hardware interrupt.

Figure 3.4.1 shows the overall interrupt processing flow.

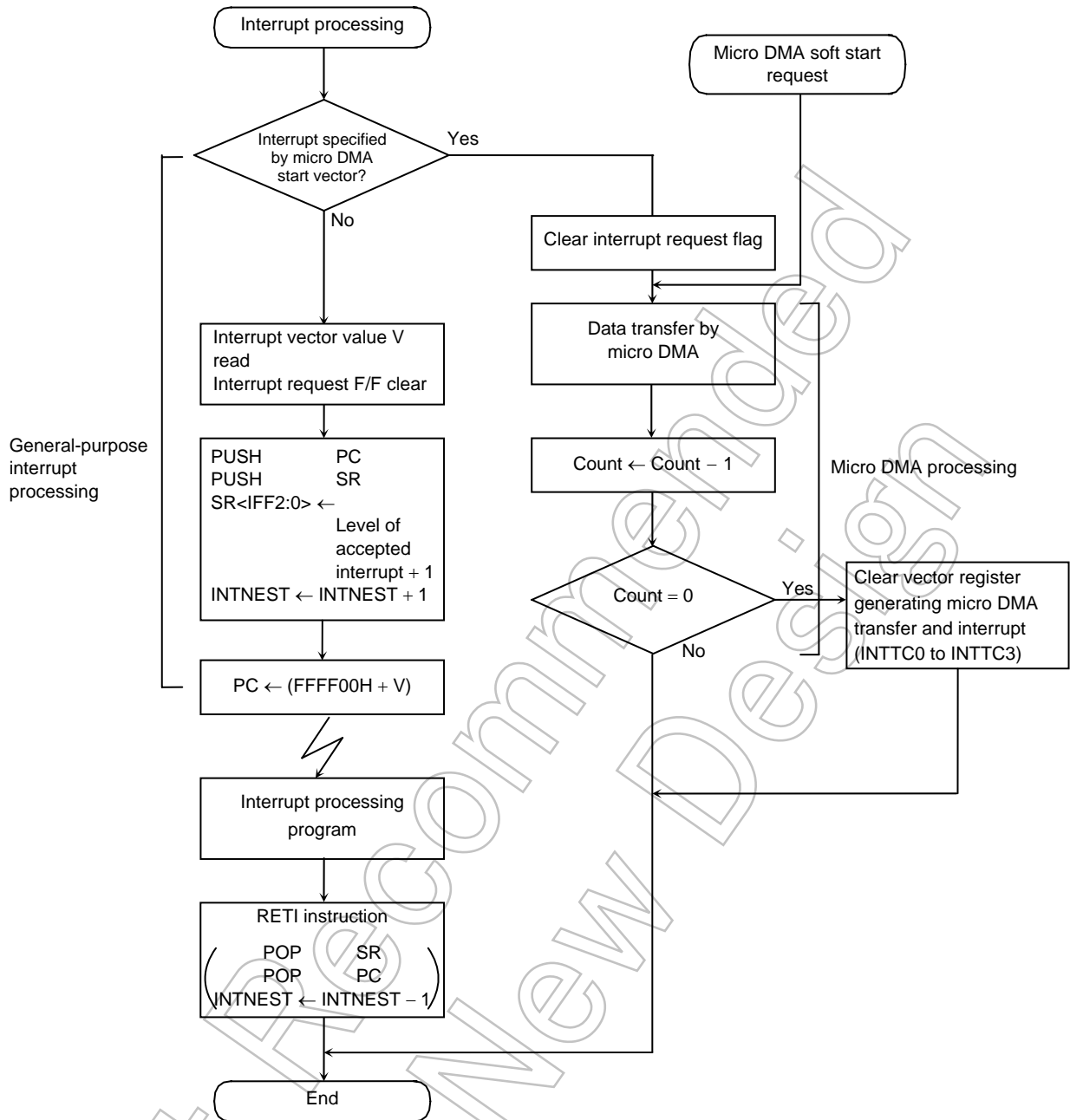

Figure 3.4.1 Overall Interrupt Processing Flow

3.4.1 General-purpose Interrupt Processing

When the CPU accepts an interrupt, it usually performs the following sequence of operations. That is also the same as TLCS-900/L and TLCS-900/H.

- (1) The CPU reads the interrupt vector from the interrupt controller.
If the same level interrupts occur simultaneously, the interrupt controller generates an interrupt vector in accordance with the default priority and clears the interrupt request.
(The default priority is already fixed for each interrupt: The smaller vector value has the higher priority level.)
- (2) The CPU pushes the value of program counter (PC) and status register (SR) onto the stack area (Indicated by XSP).
- (3) The CPU sets the value which is the priority level of the accepted interrupt plus 1 (+1) to the interrupt mask register <IFF2:0>. However, if the priority level of the accepted interrupt is 7, the register's value is set to 7.
- (4) The CPU increases the interrupt nesting counter INTNEST by 1 (+1).
- (5) The CPU jumps to the address indicated by the data at address FFFF00H + interrupt vector and starts the interrupt processing routine.
- (6) The above processing time is 18-states (1.33 μ s at 27 MHz) as the best case (16 bits data bus width and 0 waits).

When the CPU completed the interrupt processing, use the RETI instruction to return to the main routine. RETI restores the contents of program counter (PC) and status register (SR) from the stack and decreases the interrupt nesting counter INTNEST by 1 (-1).

Non-maskable interrupts cannot be disabled by a user program. Maskable interrupts, however, can be enabled or disabled by a user program. A program can set the priority level for each interrupt source. (A priority level setting of 0 or 7 will disable an interrupt request.)

If an interrupt request which has a priority level equal to or greater than the value of the CPU interrupt mask register <IFF2:0> comes out, the CPU accepts its interrupt. Then, the CPU interrupt mask register <IFF2:0> is set to the value of the priority level for the accepted interrupt plus 1 (+1).

Therefore, if an interrupt is generated with a higher level than the current interrupt during its processing, the CPU accepts the later interrupt and goes to the nesting status of interrupt processing.

Moreover, if the CPU receives another interrupt request while performing the said (1) to (5) processing steps of the current interrupt, the latest interrupt request is sampled immediately after execution of the first instruction of the current interrupt processing routine. Specifying DI as the start instruction disables maskable interrupt nesting.

A reset initializes the interrupt mask register <IFF2:0> to 111, disabling all maskable interrupts.

Table 3.4.1 shows the TMP91FY42 interrupt vectors and micro DMA start vectors. The address FFFF00H to FFFFFFFH (256 bytes) is assigned for the interrupt vector area.

Table 3.4.1 TMP91FY42 Interrupt Vectors Table

Default Priority	Type	Interrupt Source and Source of Micro DMA Request	Vector Value (V)	Vector Reference Address	Micro DMA Start Vector
1	Non maskable	Reset or "SWI 0" instruction	0000H	FFFF00H	-
2		"SWI 1" instruction	0004H	FFFF04H	-
3		INTUNDEF: Illegal instruction or "SWI 2" instruction	0008H	FFFF08H	-
4		"SWI 3" instruction	000CH	FFFF0CH	-
5		"SWI 4" instruction	0010H	FFFF10H	-
6		"SWI 5" instruction	0014H	FFFF14H	-
7		"SWI 6" instruction	0018H	FFFF18H	-
8		"SWI 7" instruction	001CH	FFFF1CH	-
9		$\overline{\text{NMI}}$ pin	0020H	FFFF20H	-
10		INTWD: Watchdog timer	0024H	FFFF24H	-
-		Micro DMA (MDMA)	-	-	-
11	Maskable	INT0 pin	0028H	FFFF28H	0AH
12		INT1 pin	002CH	FFFF2CH	0BH
13		INT2 pin	0030H	FFFF30H	0CH
14		INT3 pin	0034H	FFFF34H	0DH
15		INT4 pin	0038H	FFFF38H	0EH
16		INT5pin	003CH	FFFF3CH	0FH
17		INT6 pin	0040H	FFFF40H	10H
18		INT7 pin	0044H	FFFF44H	11H
19		INT8 pin	0048H	FFFF48H	12H
20		INTTA0: 8-bit timer 0	004CH	FFFF4CH	13H
21		INTTA1: 8-bit timer 1	0050H	FFFF50H	14H
22		INTTA2: 8-bit timer 2	0054H	FFFF54H	15H
23		INTTA3: 8-bit timer 3	0058H	FFFF58H	16H
24		INTTA4: 8-bit timer 4	005CH	FFFF5CH	17H
25		INTTA5: 8-bit timer 5	0060H	FFFF60H	18H
26		INTTA6: 8-bit timer 6	0064H	FFFF64H	19H
27		INTTA7: 8-bit timer 7	0068H	FFFF68H	1AH
28		INTTB00: 16-bit timer 0 (TBORG0)	006CH	FFFF6CH	1BH
29		INTTB01: 16-bit timer 0 (TBORG1)	0070H	FFFF70H	1CH
30		INTTB10: 16-bit timer 1 (TBORG0)	0074H	FFFF74H	1DH
31		INTTB11: 16-bit timer 1 (TBORG1)	0078H	FFFF78H	1EH
32		INTTBOF0: 16-bit timer 0 (Over-flow)	007CH	FFFF7CH	1FH
33		INTTBOF1: 16-bit timer 1 (Over-flow)	0080H	FFFF80H	20H
34		INTRX0: Serial reception (Channel 0)	0084H	FFFF84H	21H
35		INTTX0: Serial transmission (Channel 0)	0088H	FFFF88H	22H
36		INTRX1: Serial reception (Channel 1)	008CH	FFFF8CH	23H
37		INTTX1: Serial transmission (Channel 1)	0090H	FFFF90H	24H
38		INTSBI: SBI interrupt	0094H	FFFF94H	25H
39		INTRTC: Special timer for clock	0098H	FFFF98H	26H
40		INTAD: AD conversion end	009CH	FFFF9CH	27H
41		INTTC0: Micro DMA end (Channel 0)	00A0H	FFFA0H	-
42		INTTC1: Micro DMA end (Channel 1)	00A4H	FFFA4H	-
43		INTTC2: Micro DMA end (Channel 2)	00A8H	FFFA8H	-
44		INTTC3: Micro DMA end (Channel 3)	00ACH	FFFAACH	-
		(Reserved)	00B0H	FFFB0H	-
		:	:	:	:
		(Reserved)	00FCH	FFFFFCH	-

3.4.2 Micro DMA Processing

In addition to general-purpose interrupt processing, the TMP91FY42 supports a micro DMA function. Interrupt requests set by micro DMA perform micro DMA processing at the highest priority level (Level 6) among maskable interrupts, regardless of the priority level of the particular interrupt source. Micro. The micro DMA has 4 channels and is possible continuous transmission by specifying the say later burst mode.

Because the micro DMA function has been implemented with the cooperative operation of CPU, when CPU goes to a standby mode by HALT instruction, the requirement of micro DMA will be ignored (Pending).

(1) Micro DMA operation

When an interrupt request specified by the micro DMA start vector register is generated, the micro DMA triggers a micro DMA request to the CPU at interrupt priority level 6 and starts processing the request in spite of any interrupt source's level. The micro DMA is ignored on $\langle \text{IFF2:0} \rangle = 7$.

The 4 micro DMA channels allow micro DMA processing to be set for up to 4 types of interrupts at any one time. When micro DMA is accepted, the interrupt request flip-flop assigned to that channel is cleared.

The data are automatically transferred once (1/2/4 bytes) from the transfer source address to the transfer destination address set in the control register, and the transfer counter is decreased by 1 (-1).

If the decreased result is 0, the micro DMA transfer end interrupt (INTTC0 to INTTC3) passes from the CPU to the interrupt controller. In addition, the micro DMA start vector register DMAnV is cleared to 0, the next micro DMA is disabled and micro DMA processing completes. If the decreased result is other than 0, the micro DMA processing completes if it isn't specified the say later burst mode. In this case, the micro DMA transfer end interrupt (INTTC0 to INTTC3) aren't generated.

If an interrupt request is triggered for the interrupt source in use during the interval between the clearing of the micro DMA start vector and the next setting, general-purpose interrupt processing executes at the interrupt level set. Therefore, if only using the interrupt for starting the micro DMA (Not using the interrupts as a general-purpose interrupt: Level 1 to 6), first set the interrupt level to 0 (Interrupt requests disabled).

If using micro DMA and general-purpose interrupts together, first set the level of the interrupt used to start micro DMA processing lower than all the other interrupt levels. In this case, the cause of general interrupt is limited to the edge interrupt.

(Note)

The priority of the micro DMA transfer end interrupt (INTTC0 to INTTC3) is defined by the interrupt level and the default priority as the same as the other maskable interrupt.

Note: If the priority level of micro DMA is set higher than that of other interrupts, CPU operates as follows.
In case INTxxx interrupt is generated first and then INTyyy interrupt is generated between checking "Interrupt specified by micro DMA start vector" (in the Figure 3.4.1) and reading interrupt vector with setting below. The vector shifts to that of INTyyy at the time.
This is because the priority level of INTyyy is higher than that of INTxxx.
In the interrupt routine, CPU reads the vector of INTyyy because checking of micro DMA has finished.
And INTyyy is generated regardless of transfer counter of micro DMA.
INTxxx: level 1 without micro DMA
INTyyy: level 6 with micro DMA

If a micro DMA request is set for more than one channel at the same time, the priority is not based on the interrupt priority level but on the channel number. The smaller channel number has the higher priority (Channel 0 (High) > Channel 3 (Low)).

While the register for setting the transfer source/transfer destination addresses is a 32-bit control register, this register can only effectively output 24-bit addresses. Accordingly, micro DMA can access 16 Mbytes (The upper 8 bits of the 32 bits are not valid).

Three micro DMA transfer modes are supported: 1-byte transfer, 2-byte (One word) transfer, and 4-byte transfer. After a transfer in any mode, the transfer source/destination addresses are increased, decreased, or remain unchanged.

This simplifies the transfer of data from I/O to memory, from memory to I/O, and from I/O to I/O. For details of the transfer modes, see 3.4.2 (4) "Detailed description of the transfer mode register". As the transfer counter is a 16-bit counter, micro DMA processing can be set for up to 65536 times per interrupt source. (The micro DMA processing count is maximized when the transfer counter initial value is set to 0000H.)

Micro DMA processing can be started by the 30 interrupts shown in the micro DMA start vectors of Table 3.4.1 and by the micro DMA soft start, making a total of 31 interrupts.

Figure 3.4.2 shows the word transfer micro DMA cycle in transfer destination address INC mode (except for counter mode, the same as for other modes).

(The conditions for this cycle are based on an external 16-bit bus, 0 waits, transfer source/transfer destination addresses both even-numbered values.)

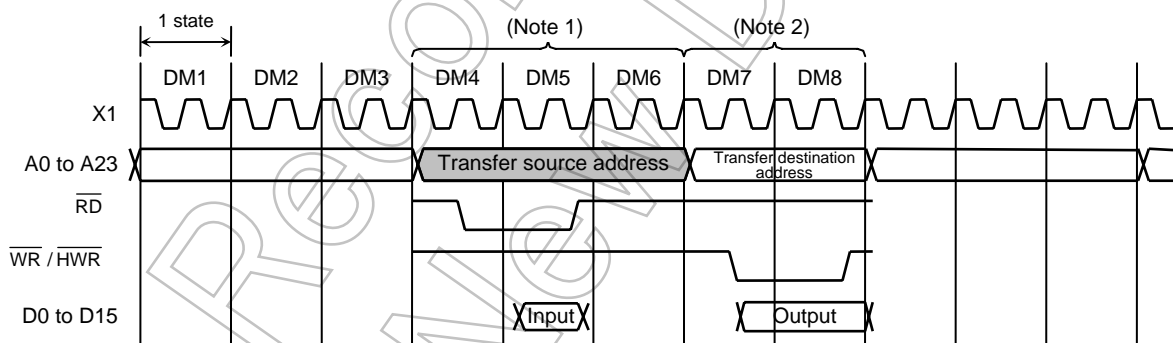

Figure 3.4.2 Timing for Micro DMA Cycle

States 1 to 3: Instruction fetch cycle (gets next address code).

If 3 bytes and more instruction codes are inserted in the instruction queue buffer, this cycle becomes a dummy cycle.

States 4 to 5: Micro DMA read cycle

State 6: Dummy cycle (The address bus remains unchanged from state 5)

States 7 to 8: Micro DMA write cycle

Note 1: If the source address area is an 8-bit bus, it is increased by two states.

If the source address area is a 16-bit bus and the address starts from an odd number, it is increased by two states.

Note 2: If the destination address area is an 8-bit bus, it is increased by two states.

If the destination address area is a 16-bit bus and the address starts from an odd number, it is increased by two states.

(2) Soft start function

In addition to starting the micro DMA function by interrupts, TMP91FY42 includes a micro DMA software start function that starts micro DMA on the generation of the write cycle to the DMAR register.

Writing “1” to each bit of DMAR register causes micro DMA once (If write “0” to each bit, micro DMA doesn’t operate). At the end of transfer, the corresponding bit of the DMAR register which support the end channel are automatically cleared to “0”.

Only one-channel can be set for DMA request at once. (Do not write “1” to plural bits.)

When writing again “1” to the DMAR register, check whether the bit is “0” before writing “1”. If read “1”, micro DMA transfer isn’t started yet.

When a burst is specified by DMAB register, data is continuously transferred until the value in the micro DMA transfer counter is “0” after start up of the micro DMA. If execute soft start during micro DMA transfer by interrupt source, micro DMA transfer counter doesn’t change. Don’t use Read-modify-write instruction to avoid writing to other bits by mistake.

Symbol	Name	Address	7	6	5	4	3	2	1	0
DMAR	DMA request register	89H (Prohibit RMW)	/	/	/	/	DMAR3	DMAR2	DMAR1	DMAR0
			/	/	/	/	R/W			
			/	/	/	/	0	0	0	0
			DMA request							

(3) Transfer control registers

The transfer source address and the transfer destination address are set in the following registers in CPU. Data setting for these registers is done by an LDC cr, r instruction.

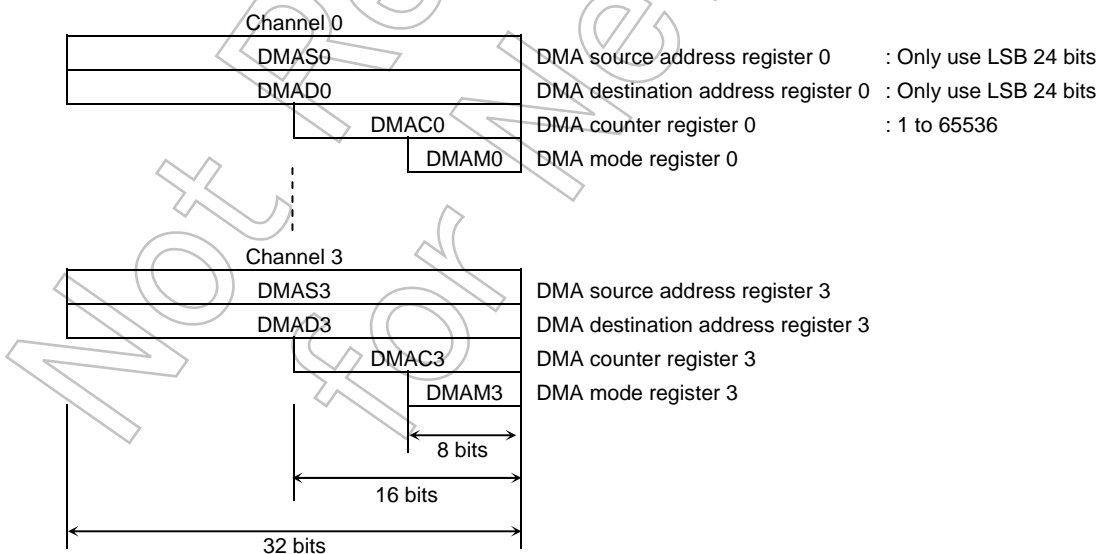

(4) Detailed description of the transfer mode register

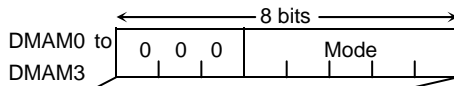

Note: When setting a value in this register, write 0 to the upper 3 bits.

			Number of Transfer Bytes	Mode Description	Number of Execution States	Minimum Execution Time at $f_c = 27$ MHz
000 (Fixed)	000	00	Byte transfer	Transfer destination address INC mode I/O to memory (DMADn+) ← (DMASn)	8 states	593 ns
		01	Word transfer	DMACn ← DMACn - 1 If DMACn = 0, then INTTCn is generated.	12 states	889 ns
		10	4-byte transfer			
	001	00	Byte transfer	Transfer destination address DEC mode I/O to memory (DMADn-) ← (DMASn)	8 states	593 ns
		01	Word transfer	DMACn ← DMACn - 1 If DMACn = 0, then INTTCn is generated.	12 states	889 ns
		10	4-byte transfer			
	010	00	Byte transfer	Transfer source address INC mode Memory to I/O (DMADn) ← (DMASn+)	8 states	593 ns
		01	Word transfer	DMACn ← DMACn - 1 If DMACn = 0, then INTTCn is generated.	12 states	889 ns
		10	4-byte transfer			
	011	00	Byte transfer	Transfer source address DEC mode Memory to I/O (DMADn) ← (DMASn-)	8 states	593 ns
		01	Word transfer	DMACn ← DMACn - 1 If DMACn = 0, then INTTCn is generated.	12 states	889 ns
		10	4-byte transfer			
100	00	Byte transfer	Fixed address mode I/O to I/O	8 states	593 ns	
	01	Word transfer	(DMADn) ← (DMASn-) DMACn ← DMACn - 1	12 states	889 ns	
	10	4-byte transfer	If DMACn = 0, then INTTCn is generated.			
101	00	Counter mode for counting number of times interrupt is generated DMASn ← DMASn + 1 DMACn ← DMACn - 1 If DMACn = 0, then INTTCn is generated.	5 states	370 ns		

Note 1: "n" is the corresponding micro DMA channels 0 to 3

DMADn+/DMASn+: Post-increment (Increment register value after transfer)

DMADn-/DMASn-: Post-decrement (Decrement register value after transfer)

The I/Os in the table mean fixed address and the memory means increment (INC) or decrement (DEC) addresses.

Note 2: Execution time is under the condition of:

16-bit bus width (Both translation and destination address area)/0 waits/ $f_c = 27$ MHz/selected high-frequency mode ($f_c \times 1$)

Note 3: Do not use an undefined code for the transfer mode register except for the defined codes listed in the above table.

3.4.3 Interrupt Controller Operation

The block diagram in Figure 3.4.3 shows the interrupt circuits. The left-hand side of the diagram shows the interrupt controller circuit. The right-hand side shows the CPU interrupt request signal circuit and the halt release circuit.

For each of the 45 interrupt channels there is an interrupt request flag (Consisting of a flip-flop), an interrupt priority setting register and a micro DMA start vector register. The interrupt request flag latches interrupt requests from the peripherals. The flag is cleared to zero in the following cases:

- when reset occurs
- when the CPU reads the channel vector after accepted its interrupt
- when executing an instruction that clears the interrupt (Write DMA start vector to INTCLR register)
- when the CPU receives a micro DMA request (when micro DMA is set)
- when the micro DMA burst transfer is terminated

An interrupt priority can be set independently for each interrupt source by writing the priority to the interrupt priority setting register (e.g., INTE0AD or INTE12). 6 interrupt priorities levels (1 to 6) are provided. Setting an interrupt source's priority level to 0 (or 7) disables interrupt requests from that source. The priority of non-maskable interrupts (NMI pin interrupts and watchdog timer interrupts) is fixed at 7. If interrupt request with the same level are generated at the same time, the default priority (The interrupt with the lowest priority or, in other words, the interrupt with the lowest vector value) is used to determine which interrupt request is accepted first.

The 3rd and 7th bits of the interrupt priority setting register indicate the state of the interrupt request flag and thus whether an interrupt request for a given channel has occurred.

The interrupt controller sends the interrupt request with the highest priority among the simultaneous interrupts and its vector address to the CPU. The CPU compares the priority value $\langle IFF2:0 \rangle$ in the status register by the interrupt request signal with the priority value set; if the latter is higher, the interrupt is accepted. Then the CPU sets a value higher than the priority value by 1 (+1) in the CPU SR $\langle IFF2:0 \rangle$. Interrupt request where the priority value equals or is higher than the set value are accepted simultaneously during the previous interrupt routine.

When interrupt processing is completed (after execution of the RETI instruction), the CPU restores the priority value saved in the stack before the interrupt was generated to the CPU SR $\langle IFF2:0 \rangle$.

The interrupt controller also has registers (4 channels) used to store the micro DMA start vector. Writing the start vector of the interrupt source for the micro DMA processing (See Table 3.4.1), enables the corresponding interrupt to be processed by micro DMA processing. The values must be set in the micro DMA parameter register (e.g., DMAS and DMAD) prior to the micro DMA processing.

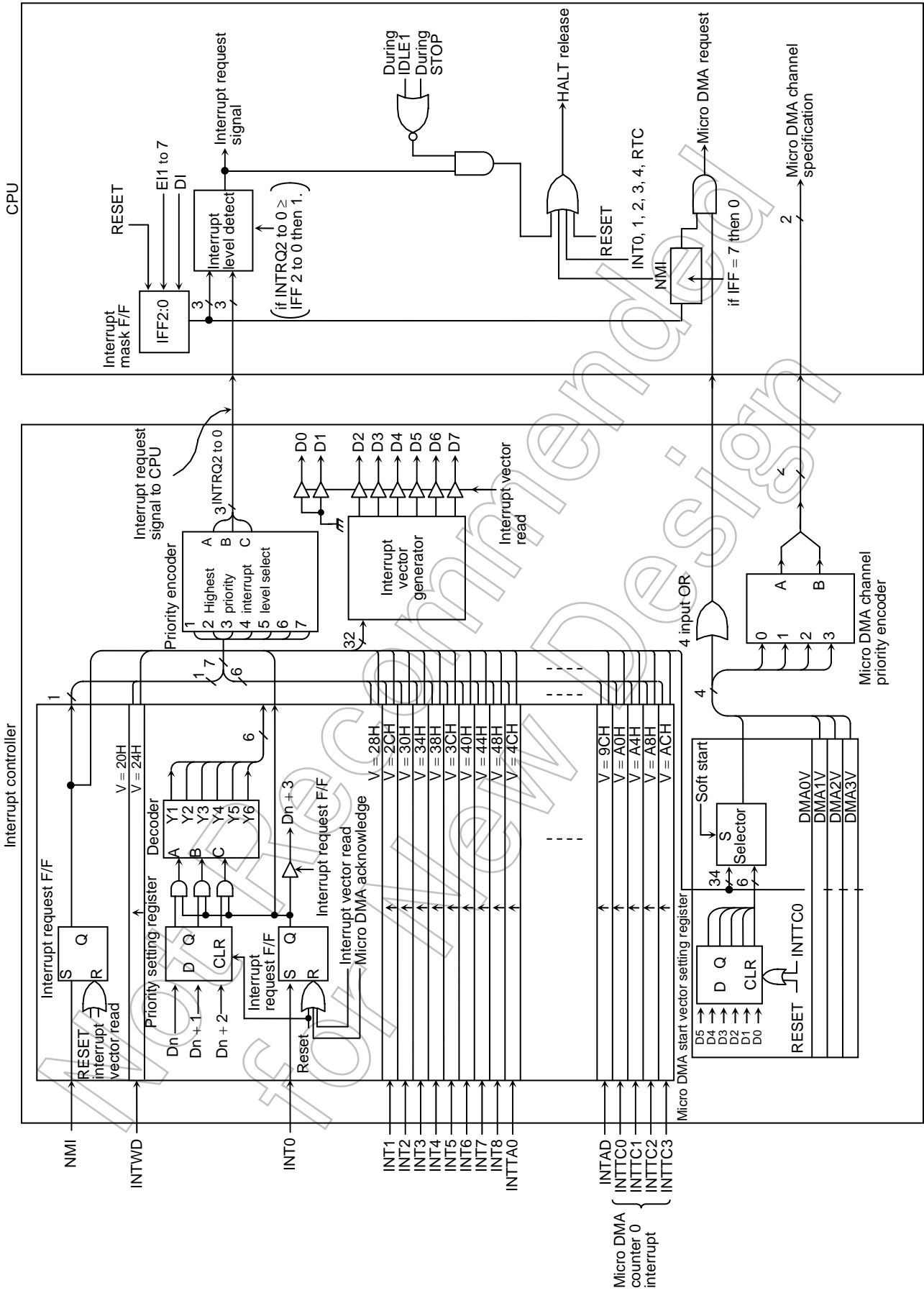
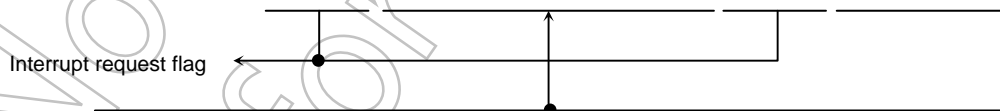

Figure 3.4.3 Block Diagram of Interrupt Controller

(1) Interrupt level setting registers

Symbol	Name	Address	7	6	5	4	3	2	1	0
INTE0AD	INT0 & INTAD enable	90H	INTAD				INT0			
			IADC	IADM2	IADM1	IADM0	I0C	I0M2	I0M1	I0M0
			R	R/W			R	R/W		
			0	0	0	0	0	0	0	0
INTE12	INT1 & INT2 enable	91H	INT2				INT1			
			I2C	I2M2	I2M1	I2M0	I1C	I1M2	I1M1	I1M0
			R	R/W			R	R/W		
			0	0	0	0	0	0	0	0
INTE34	INT3& INT4 enable	92H	INT4				INT3			
			I4C	I4M2	I4M1	I4M0	I3C	I3M2	I3M1	I3M0
			R	R/W			R	R/W		
			0	0	0	0	0	0	0	0
INTE56	INT5 & INT6 enable	93H	INT6				INT5			
			I6C	I6M2	I6M1	I6M0	I5C	I5M2	I5M1	I5M0
			R	R/W			R	R/W		
			0	0	0	0	0	0	0	0
INTE78	INT7 & INT8 enable	94H	INT8				INT7			
			I8C	I8M2	I8M1	I8M0	I7C	I7M2	I7M1	I7M0
			R	R/W			R	R/W		
			0	0	0	0	0	0	0	0
INTEA01	INTTA0 & INTTA1 enable	95H	INTTA1 (TMRA1)				INTTA0 (TMRA0)			
			ITA1C	ITA1M2	ITA1M1	ITA1M0	ITA0C	ITA0M2	ITA0M1	ITA0M0
			R	R/W			R	R/W		
			0	0	0	0	0	0	0	0
INTEA23	INTTA2 & INTTA3 enable	96H	INTTA3 (TMRA3)				INTTA2 (TMRA2)			
			ITA3C	ITA3M2	ITA3M1	ITA3M0	ITA2C	ITA2M2	ITA2M1	ITA2M0
			R	R/W			R	R/W		
			0	0	0	0	0	0	0	0
INTEA45	INTTA4 & INTTA5 enable	97H	INTTA5 (TMRA5)				INTTA4 (TMRA4)			
			ITA5C	ITA5M2	ITA5M1	ITA5M0	ITA4C	ITA4M2	ITA4M1	ITA4M0
			R	R/W			R	R/W		
			0	0	0	0	0	0	0	0
INTEA67	INTTA6 & INTTA7 enable	98H	INTTA7 (TMRA7)				INTTA6 (TMRA6)			
			ITA7C	ITA7M2	ITA7M1	ITA7M0	ITA6C	ITA6M2	ITA6M1	ITA6M0
			R	R/W			R	R/W		
			0	0	0	0	0	0	0	0



IxxM2	IxxM1	IxxM0	Function (Write)
0	0	0	Disables interrupt requests
0	0	1	Sets interrupt priority level to 1
0	1	0	Sets interrupt priority level to 2
0	1	1	Sets interrupt priority level to 3
1	0	0	Sets interrupt priority level to 4
1	0	1	Sets interrupt priority level to 5
1	1	0	Sets interrupt priority level to 6
1	1	1	Disables interrupt requests

Symbol	Name	Address	7	6	5	4	3	2	1	0
INTETB0	INTTB00 & INTTB01 enable	99H	INTTB01 (TMRB0)				INTTB00 (TMRB0)			
			ITB01C	ITB01M2	ITB01M1	ITB01M0	ITB00C	ITB00M2	ITB00M1	ITB00M0
			R	R/W			R	R/W		
			0	0	0	0	0	0	0	0
INTETB1	INTTB10 & INTTB11 enable	9AH	INTTB11 (TMRB1)				INTTB10 (TMRB1)			
			ITB11C	ITB11M2	ITB11M1	ITB11M0	ITB10C	ITB10M2	ITB10M1	ITB10M0
			R	R/W			R	R/W		
			0	0	0	0	0	0	0	0
INTETB01V	INTTBOF0 & INTTBOF1 enable (Over flow)	9BH	INTTBOF1 (TMRB1 Over-flow)				INTTBOF0 (TMRB0 Over-flow)			
			ITF1C	ITF1M2	ITF1M1	ITF1M0	ITF0C	ITF0M2	ITF0M1	ITF0M0
			R	R/W			R	R/W		
			0	0	0	0	0	0	0	0
INTES0	INTRX0 & INTTX0 enable	9CH	INTTX0				INTRX0			
			ITX0C	ITX0M2	ITX0M1	ITX0M0	IRX0C	IRX0M2	IRX0M1	IRX0M0
			R	R/W			R	R/W		
			0	0	0	0	0	0	0	0
INTES1	INTRX1 & INTTX1 enable	9DH	INTTX1				INTRX1			
			ITX1C	ITX1M2	ITX1M1	ITX1M0	IRX1C	IRX1M2	IRX1M1	IRX1M0
			R	R/W			R	R/W		
			0	0	0	0	0	0	0	0
INTES2RTC	INTSBI & RTC enable	9EH	INTRTC				INTSBI			
			IRTC	IRTCM2	IRTCM1	IRTCM0	ISBIC	ISBIM2	ISBIM1	ISBIM0
			R	R/W			R	R/W		
			0	0	0	0	0	0	0	0
INTETC01	INTTC0 & INTTC1 enable	A0H	INTTC1				INTTC0			
			ITC1C	ITC1M2	ITC1M1	ITC1M0	ITC0C	ITC0M2	ITC0M1	ITC0M0
			R	R/W			R	R/W		
			0	0	0	0	0	0	0	0
INTETC23	INTTC2 & INTTC3 enable	A1H	INTTC3				INTTC2			
			ITC3C	ITC3M2	ITC3M1	ITC3M0	ITC2C	ITC2M2	ITC2M1	ITC2M0
			R	R/W			R	R/W		
			0	0	0	0	0	0	0	0

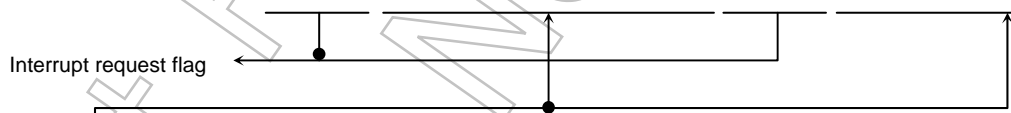

lxxM2	lxxM1	lxxM0	Function (Write)
0	0	0	Disables interrupt requests
0	0	1	Sets interrupt priority level to 1
0	1	0	Sets interrupt priority level to 2
0	1	1	Sets interrupt priority level to 3
1	0	0	Sets interrupt priority level to 4
1	0	1	Sets interrupt priority level to 5
1	1	0	Sets interrupt priority level to 6
1	1	1	Disables interrupt requests

(2) External interrupt control

Symbol	Name	Address	7	6	5	4	3	2	1	0	
IIMC	Interrupt input mode control	8CH (Prohibit RMW)	–	I4EDGE	I3EDGE	I2EDGE	I1EDGE	I0EDGE	I0LE	NMIREE	
			W								
			0	0	0	0	0	0	0	0	
			Always write 0	INT4EDGE 0: Rising 1: Falling	INT3EDGE 0: Rising 1: Falling	INT2EDGE 0: Rising 1: Falling	INT1EDGE 0: Rising 1: Falling	INT0EDGE 0: Rising 1: Falling	INT0 mode 0: Edge 1: Level	1: Operates even on rising/falling edge of $\overline{\text{NMI}}$	

INT0 level enable

0	edge detect INT
1	H level INT

NMI rising edge enable

0	INT request generation at falling edge
1	INT request generation at rising/falling edge

(3) Interrupt request flag clear register

The interrupt request flag is cleared by writing the appropriate micro DMA start vector, as given in Table 3.4.1, to the register INTCLR.

For example, to clear the interrupt flag INT0, perform the following register operation after execution of the DI instruction.

INTCLR ← 0AH: Clears interrupt request flag INT0.

Symbol	Name	Address	7	6	5	4	3	2	1	0	
INTCLR	Interrupt clear control	88H (Prohibit RMW)			CLR5	CLR4	CLR3	CLR2	CLR1	CLR0	
			W								
					0	0	0	0	0	0	
			Interrupt vector								

(4) Micro DMA start vector registers

This register assigns micro DMA processing to which interrupt source. The interrupt source with a micro DMA start vector that matches the vector set in this register is assigned as the micro DMA start source.

When the micro DMA transfer counter value reaches zero, the micro DMA transfer end interrupt corresponding to the channel is sent to the interrupt controller, the micro DMA start vector register is cleared, and the micro DMA start source for the channel is cleared. Therefore, to continue micro DMA processing, set the micro DMA start vector register again during the processing of the micro DMA transfer end interrupt.

If the same vector is set in the micro DMA start vector registers of more than one channel, the channel with the lowest number has a higher priority.

Accordingly, if the same vector is set in the micro DMA start vector registers of two channels, the interrupt generated in the channel with the lower number is executed until micro DMA transfer is complete. If the micro DMA start vector for this channel is not set again, the next micro DMA is started for the channel with the higher number (Micro DMA chaining).

Symbol	Name	Address	7	6	5	4	3	2	1	0
DMA0V	DMA0 start vector	80H	/	/	DMA0V5	DMA0V4	DMA0V3	DMA0V2	DMA0V1	DMA0V0
					R/W					
					0	0	0	0	0	0
					DMA0 start vector					
DMA1V	DMA1 start vector	81H	/	/	DMA1V5	DMA1V4	DMA1V3	DMA1V2	DMA1V1	DMA1V0
					R/W					
					0	0	0	0	0	0
					DMA1 start vector					
DMA2V	DMA2 start vector	82H	/	/	DMA2V5	DMA2V4	DMA2V3	DMA2V2	DMA2V1	DMA2V0
					R/W					
					0	0	0	0	0	0
					DMA2 start vector					
DMA3V	DMA3 start vector	83H	/	/	DMA3V5	DMA3V4	DMA3V3	DMA3V2	DMA3V1	DMA3V0
					R/W					
					0	0	0	0	0	0
					DMA3 start vector					

(5) Micro DMA burst specification

Specifying the micro DMA burst continues the micro DMA transfer until the transfer counter register reaches zero after micro DMA start. Setting a bit which corresponds to the micro DMA channel of the DMAB registers mentioned below to 1 specifies a burst.

Symbol	Name	Address	7	6	5	4	3	2	1	0
DMAR	DMA software request register (Prohibit RMW)	89H	/	/	/	/	DMAR3	DMAR2	DMAR1	DMAR0
							R/W			
							0	0	0	0
							1: DMA software request			
DMAB	DMA burst register	8AH	/	/	/	/	DMAB3	DMAB2	DMAB1	DMAB0
							R/W			
							0	0	0	0
							1. DMA burst request			

(6) Attention point

The instruction execution unit and the bus interface unit of this CPU operate independently. Therefore, immediately before an interrupt is generated, if the CPU fetches an instruction that clears the corresponding interrupt request flag, the CPU may execute the instruction that clears the interrupt request flag (Note) between accepting and reading the interrupt vector. In this case, the CPU reads the default vector 0008H and reads the interrupt vector address FFFF08H.

To avoid the above program, place instructions that clear interrupt request flags after a DI instruction. And in the case of setting an interrupt enable again by EI instruction after the execution of clearing instruction, execute EI instruction after clearing and more than 1-instructions (e.g., "NOP" × 1 times).

In the case of changing the value of the interrupt mask register <IFF2:0> by execution of POP SR instruction, disable an interrupt by DI instruction before execution of POP SR instruction.

In addition, take care as the following 2 circuits are exceptional and demand special attention.

INT0 Level Mode	<p>In level mode INT0 is not an edge-triggered interrupt. Hence, in level mode the interrupt request flip-flop for INT0 does not function. The peripheral interrupt request passes through the S input of the flip-flop and becomes the Q output. If the interrupt input mode is changed from edge mode to level mode, the interrupt request flag is cleared automatically.</p> <p>If the CPU enters the interrupt response sequence as a result of INT0 going from 0 to 1, INT0 must then be held at 1 until the interrupt response sequence has been completed. If INT0 is set to level mode so as to release a halt state, INT0 must be held at 1 from the time INT0 changes from 0 to 1 until the halt state is released. (Hence, it is necessary to ensure that input noise is not interpreted as a 0, causing INT0 to revert to 0 before the halt state has been released.)</p> <p>When the mode changes from level mode to edge mode, interrupt request flags which were set in level mode will not be cleared. Interrupt request flags must be cleared using the following sequence.</p> <pre>DI LD (IIMC), 00H; Switches interrupt input mode from level mode to edge mode. LD (INTCLR), 0AH; Clears interrupt request flag. NOP ; Wait EI instruction EI</pre>
INTRX	<p>The interrupt request flip-flop can only be cleared by a reset or by reading the serial channel receive buffer. It cannot be cleared by writing INTCLR register.</p>

Note: The following instructions or pin input state changes are equivalent to instructions that clear the interrupt request flag.

INT0: Instructions which switch to level mode after an interrupt request has been generated in edge mode.

The pin input change from high to low after interrupt request has been generated in level mode. (H → L)

INTRX: Instruction which read the receive buffer

3.5 Port Functions

The TMP91FY42 features 81-bit settings which relate to the various I/O ports.

As well as general-purpose I/O port functionality, the port pins also have I/O functions which relate to the built-in CPU and internal I/Os. Table 3.5.1 list the functions of each port pin. Table 3.5.2 list I/O registers and their specifications.

Table 3.5.1 Port Functions (1/2)

(R: PU = with programmable pull-up resistor)

Port Name	Pin Name	Number of Pins	Direction	R	Direction Setting Unit	Pin Name for Built-in Function
Port 0	P00~P07	8	I/O	–	Bit	AD0 to AD7
Port 1	P10~P17	8	I/O	–	Bit	AD8 to AD15/A8 to A15
Port 2	P20~P27	8	I/O	–	Bit	A16 to A23/A0 to A7
Port 3	P30	1	Output	–	Bit	\overline{WR}
	P31	1	Output	–	Bit	\overline{HWR}
	P32	1	I/O	PU	Bit	\overline{WAIT}
	P33	1	I/O	PU	Bit	\overline{BUSRQ}
	P34	1	I/O	PU	Bit	\overline{BUSAk}
	P35	1	I/O	PU	Bit	\overline{BUSAk}
	P36	1	I/O	PU	Bit	R / \overline{W}
	P37	1	I/O	PU	Bit	
Port 4	P40	1	I/O	PU	Bit	$\overline{CS0}$
	P41	1	I/O	PU	Bit	$\overline{CS1}$
	P42	1	I/O	PU	Bit	$\overline{CS2}$
	P43	1	I/O	PU	Bit	$\overline{CS3}$
Port 5	P50 to P57	8	Input	–	(Fixed)	AN0 to AN7, \overline{ADTRG} (P53)
Port 6	P60	1	I/O	–	Bit	SCK
	P61	1	I/O	–	Bit	SO/SDA
	P62	1	I/O	–	Bit	SI/SCL
	P63	1	I/O	–	Bit	INT0
	P64	1	I/O	–	Bit	SCOUT
	P65	1	I/O	–	Bit	
	P66	1	I/O	–	Bit	
Port 7	P70	1	I/O	–	Bit	TA0IN
	P71	1	I/O	–	Bit	TA1OUT
	P72	1	I/O	–	Bit	TA3OUT
	P73	1	I/O	–	Bit	TA4IN
	P74	1	I/O	–	Bit	TA5OUT
	P75	1	I/O	–	Bit	TA7OUT
	Port 8	P80	1	I/O	–	Bit
P81		1	I/O	–	Bit	TB0IN1/INT6
P82		1	I/O	–	Bit	TB0OUT0
P83		1	I/O	–	Bit	TB0OUT1
P84		1	I/O	–	Bit	TB1IN0/INT7
P85		1	I/O	–	Bit	TB1IN1/INT8
P86		1	I/O	–	Bit	TB1OUT0
P87		1	I/O	–	Bit	TB1OUT1
Port 9	P90	1	I/O	–	Bit	TXD0
	P91	1	I/O	–	Bit	RXD0
	P92	1	I/O	–	Bit	SCLK0/ $\overline{CTS0}$
	P93	1	I/O	–	Bit	TXD1
	P94	1	I/O	–	Bit	RXD1
	P95	1	I/O	–	Bit	SCLK1/ $\overline{CTS1}$
	P96	1	I/O	–	Bit	XT1
	P97	1	I/O	–	Bit	XT2
Port A	PA0 to PA3	4	I/O	–	Bit	INT1 to INT4
	PA4 to PA7	4	I/O	–	Bit	

Table 3.5.2 I/O Registers and Specifications (1/3)

Port	Pin Name	Specification	After reset	I/O Register		
				Pn	PnCR	PnFC
Port 0	P00 to P07	Input port	●	x	0	None
		Output port		x	1	
		AD0 to AD7 bus (Note 1)		x	x	
Port 1	P10 to P17	Input port	●	x	0	0
		Output port		x	1	0
		AD8 to AD15 bus (Note 1)		x	0	1
		A8 to A15		x	1	1
Port 2	P20 to P27	Input port	●	x	0	0
		Output port		x	1	0
		A0 to A7 output		x	0	1
		A16 to A23 output		x	1	1
Port 3	P30	Output port	●	x	None	0
		Outputs \overline{RD} only when accessing external space		1		1
		Always \overline{RD} output		0		1
	P31	Output port	●	x	None	0
		Outputs \overline{WR} only when accessing external space		x		1
	P32 to P37	Input port (without PU)		0	0	0
		Input port (with PU)	●	1	0	0
		Output port		x	1	0
	P32	HWR output		x	1	1
	P33	WAIT input (without PU)		0	0	None
		WAIT input (with PU)		1	0	
	P34	BUSRQ input (without PU)		0	0	1
		BUSRQ input (with PU)		1	0	1
	P35	BUSAK output		x	1	1
P36	R/W output		x	1	1	
Port 4	P40 to P43	Input port (without PU)		0	0	0
		Input port (with PU)	●	1	0	0
		Output port		x	1	0
	P40	$\overline{CS0}$ output		x	1	1
	P41	$\overline{CS1}$ output		x	1	1
	P42	$\overline{CS2}$ output		x	1	1
	P43	$\overline{CS3}$ output		x	1	1
Port 5	P50 to P57	Input port	●	x	None	
		AN0 to AN7 input		x		
	P53	ADTRG input		x		
Port 6	P60 to P66	Input port	●	x	0	0
		Output port		x	1	0
	P60	SCK input		x	0	0
		SCK output		x	1	1
	P61	SDA input		x	0	0
		SDA output (Note 2)		x	1	1
		SO output		x	1	1
	P62	SI input		x	0	0
		SCL input		x	0	0
		SCL output (Note 2)		x	1	1
P63	INT0 input		x	0	1	
P64	SCOUT output		x	1	1	

Table 3.5.3 I/O Registers and Specifications (2/3)

Port	Pin Name	Specification	After reset	I/O Register		
				Pn	PnCR	PnFC
Port 7	P70 to P75	Input port	●	x	0	0
		Output port		x	1	0
	P70	TA0IN input		x	0	None
	P71	TA1OUT output		x	1	1
	P72	TA3OUT output		x	1	1
	P73	TA4IN input		x	0	None
	P74	TA5OUT output		x	1	1
	P75	TA7OUT output		x	1	1
Port 8	P80 to P87	Input port	●	x	0	0
		Output port		x	1	0
	P80	TB0IN0, INT5 input		x	0	1
	P81	TB0IN1, INT6 input		x	0	1
	P82	TB0OUT0 output		x	1	1
	P83	TB0OUT1 output		x	1	1
	P84	TB1IN0, INT7 input		x	0	1
	P85	TB1IN1, INT8 input		x	0	1
	P86	TB1OUT0 output		x	1	1
P87	TB1OUT1 output		x	1	1	
Port 9	P90 to P95	Input port	●	x	0	0
		Output port		x	1	0
	P90	TXD0 output		x	1	1
	P91	RXD0 input		x	0	None
	P92	SCLK0 input		x	0	0
		SCLK0 output		x	1	1
		CTS0 input		x	0	0
	P93	TXD1 output		x	1	1
	P94	RXD1 input		x	0	None
	P95	SCLK1 input		x	0	0
		SCLK1 output		x	1	1
		CTS1 input		x	0	0
	P96 to P97	Input port		x	0	None
		Output port (Note 3)	●	x	1	
XT1 to XT2			x	0		
Port A	PA0 to PA7	Input port	●	x	0	0
		Output port		x	1	0
	PA0	INT1 input		x	0	1
	PA1	INT2 input		x	0	1
	PA2	INT3 input		x	0	1
	PA3	INT4 input		x	0	1

X: Don't care

Note 1: There is not port setting for changing AD0 to AD7 pins. It function is changed automatically by accessing external area.

Note 2: When P61/P62 are used as SDA/SCL open-drain outputs, P60DE<ODEP62:61> is used to set the open-drain output mode.

Note 3: In case using P96 to P97 as Output port, it is open-drain output buffer.

- Note about bus release and programmable pull-up I/O port pins

When the bus is released (e.g., when $\overline{\text{BUSAK}} = 0$), the output buffers for AD0 to AD15, A0 to A23, and the control signals ($\overline{\text{RD}}$, $\overline{\text{WR}}$, $\overline{\text{HWR}}$, $\text{R}/\overline{\text{W}}$ and $\overline{\text{CS0}}$ to $\overline{\text{CS3}}$) are off and are set to high-impedance.

However, the output of built-in programmable pull-up resistors are kept before the bus is released. These programmable pull-up resistors can be selected ON/OFF by programmable when they are used as the input ports.

When they are used as output ports, they cannot be turned ON/OFF in software.

Table 3.5.4 shows the pin states after the bus has been released.

Table 3.5.4 Pin states (after bus release)

Pin Name	The Pin State (when the bus is released)	
	Port Mode	Function Mode
P00~P07 (AD0~AD7) P10~P17 (AD8~AD15/A8~A15)	The state is not changed. (Don't become to high-impedance (HZ)).	Become high-impedance (HZ).
P20~P27 (A16~A23)	↑	First sets all bits to high then sets them to High-impedance (HZ).
P30 ($\overline{\text{RD}}$) P31 ($\overline{\text{WR}}$)	↑	↑
P32 ($\overline{\text{HWR}}$) P37	↑	Output buffer is OFF. The programmable pull up resistor is ON irrespective of the output.
P36 ($\text{R}/\overline{\text{W}}$) P40 ($\overline{\text{CS0}}$) P41 ($\overline{\text{CS1}}$) P42 ($\overline{\text{CS2}}$) P43 ($\overline{\text{CS3}}$)	↑	↑

Figure 3.5.1 shows an example external interface circuit when the bus release function is used.

When the bus is released, neither the internal memory nor the internal I/O can be accessed. However, the internal I/O continues to operate. As a result, the watchdog timer also continues to run. Therefore, the bus release time must be taken into account and care must be taken when setting the detection time for the WDT.

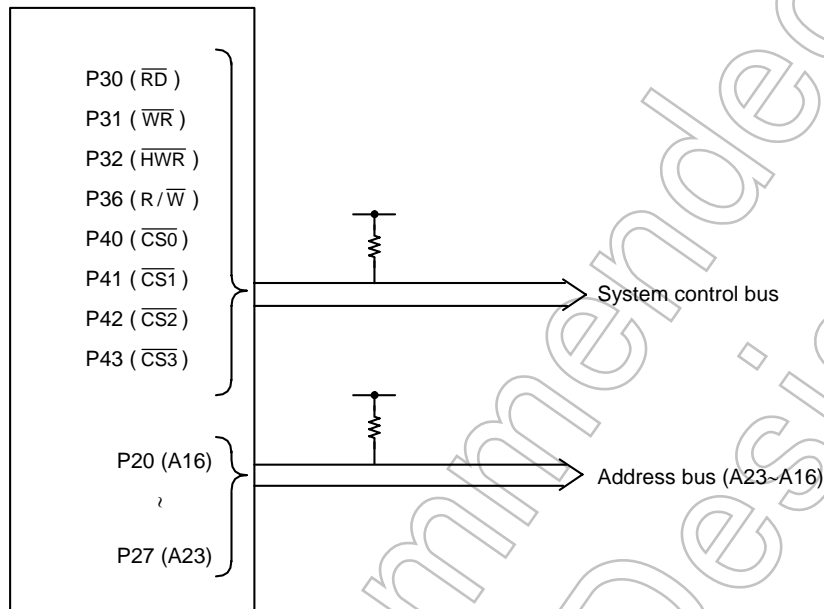

Figure 3.5.1 Interface Circuit Example (Using bus release function)

The above circuit is necessary to set the signal level when the bus is released.

A reset sets P30 (\overline{RD}) and P31 (\overline{WR}) to output, and P40 ($\overline{CS0}$), P41 ($\overline{CS1}$), P42 ($\overline{CS2}$), P43 ($\overline{CS3}$), P32 (\overline{HWR}) and P35 (\overline{BUSAk}) to input with pull-up resistor.

3.5.1 Port 0 (P00 to P07)

Port 0 is an 8-bit general-purpose I/O port. Each bit can be set individually for input or output using the control register P0CR. Resetting resets all bits of the output latch P0, the control register P0CR to 0 and sets port 0 to input mode. In addition to functioning as a general-purpose I/O port, port 0 can also function as an Address data bus (AD0 to AD7).

When external memory is accessed, the port automatically functions as the Address data bus (AD0 to AD7) and all bits of P0CR are cleared to 0.

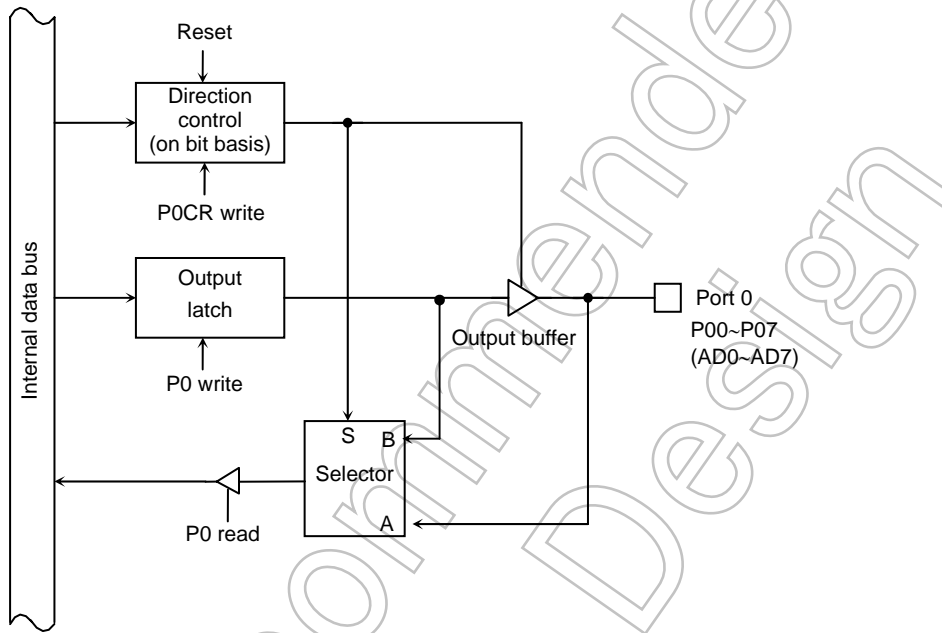

Figure 3.5.2 Port 0

		7	6	5	4	3	2	1	0
P0 (0000H)	Bit symbol	P07	P06	P05	P04	P03	P02	P01	P00
	Read/Write	R/W							
	After reset	Data from external port (Output latch register is cleared to 0.)							
Port 0 Control Register									
		7	6	5	4	3	2	1	0
P0CR (0002H)	Bit symbol	P07C	P06C	P05C	P04C	P03C	P02C	P01C	P00C
	Read/Write	W							
	After reset	0	0	0	0	0	0	0	0
	Function	Port 0 input/output settings 0: Input 1:Output							

Note 1: Read-modify-write is prohibited for P0CR.

Note 2: When accessing external, P0CR is AD0 to AD7 and it is cleared to 0.

Figure 3.5.3 Register for Port 0

3.5.2 Port 1 (P10 to P17)

Port 1 is an 8-bit general-purpose I/O port. Each bit can be set individually for input or output using the control register P1CR and the function register P1FC. Resetting resets all bits of the output latch P1, the control register P1CR and the function register P1FC to 0 and sets port 1 to input mode.

In addition to functioning as a general-purpose I/O port, port 1 can also function as an Address data bus (AD8 to AD15) and Address bus (A8 to A15).

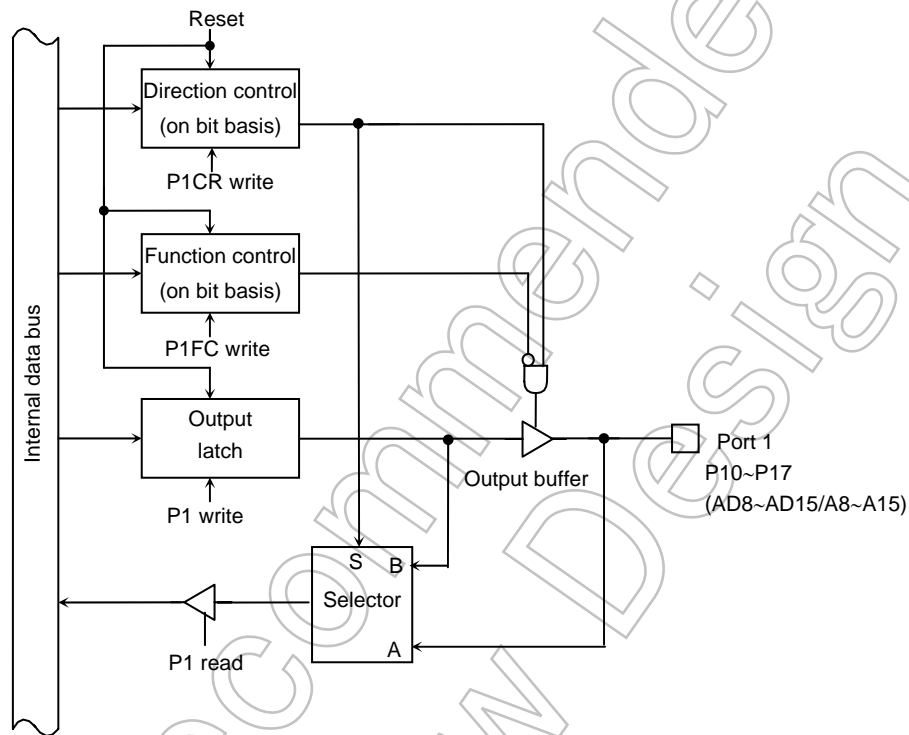

Figure 3.5.4 Port 1

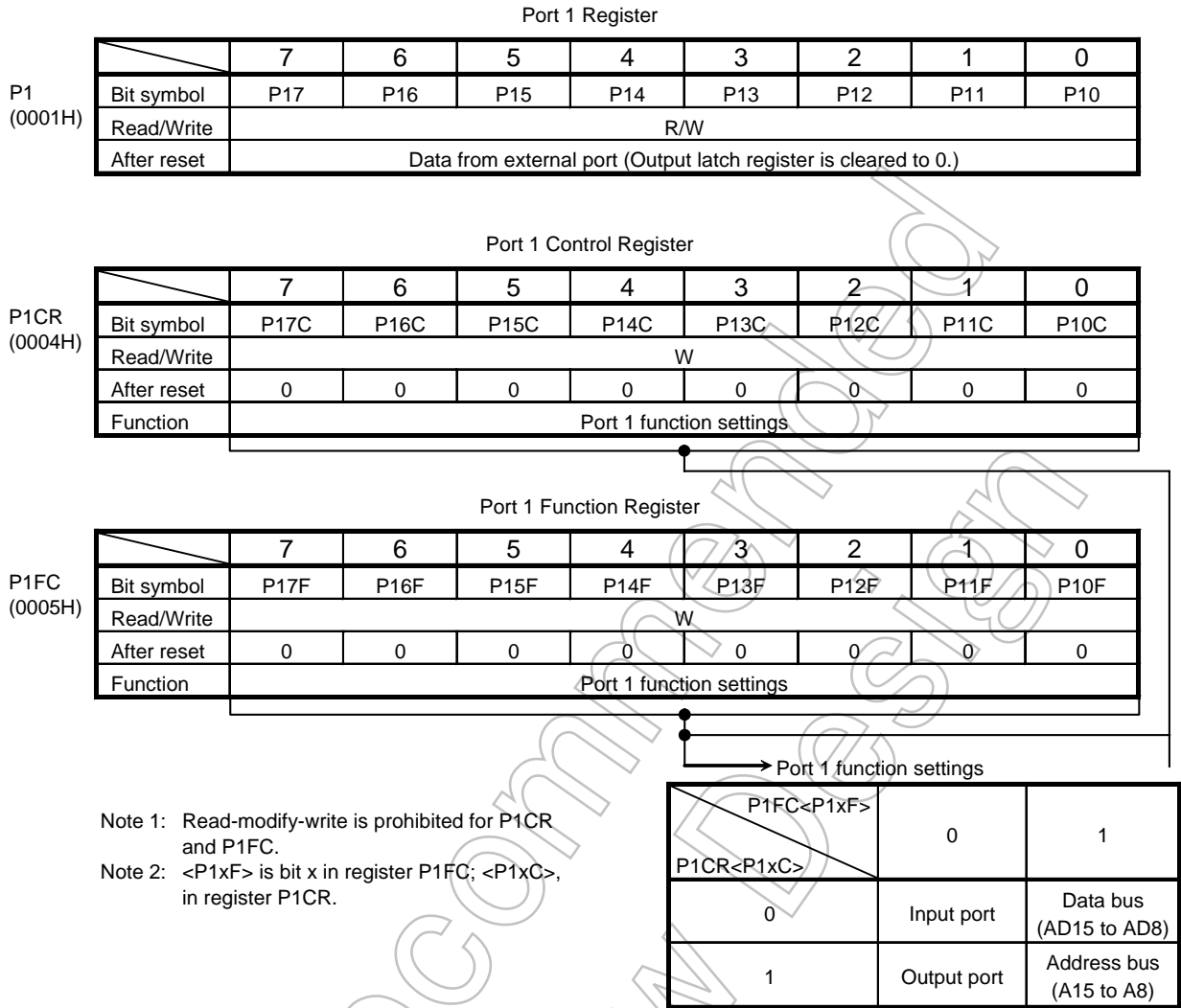

Figure 3.5.5 Register for Port 1

3.5.3 Port 2 (P20 to P27)

Port 2 is an 8-bit general-purpose I/O port. Each bit can be set individually for input or output using the control register P2CR and the function register P2FC. In addition to functioning as a general-purpose I/O port, port 2 can also function as an address bus (A0 to A7) and (A16 to A23).

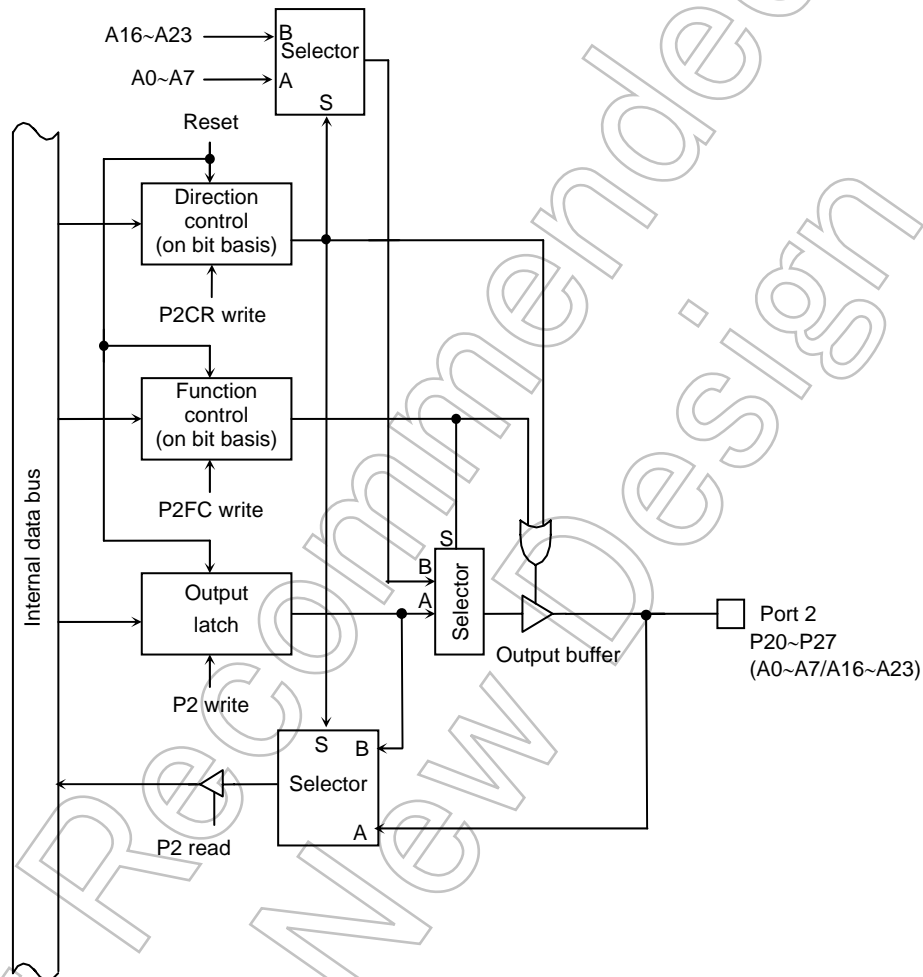

Figure 3.5.6 Port 2

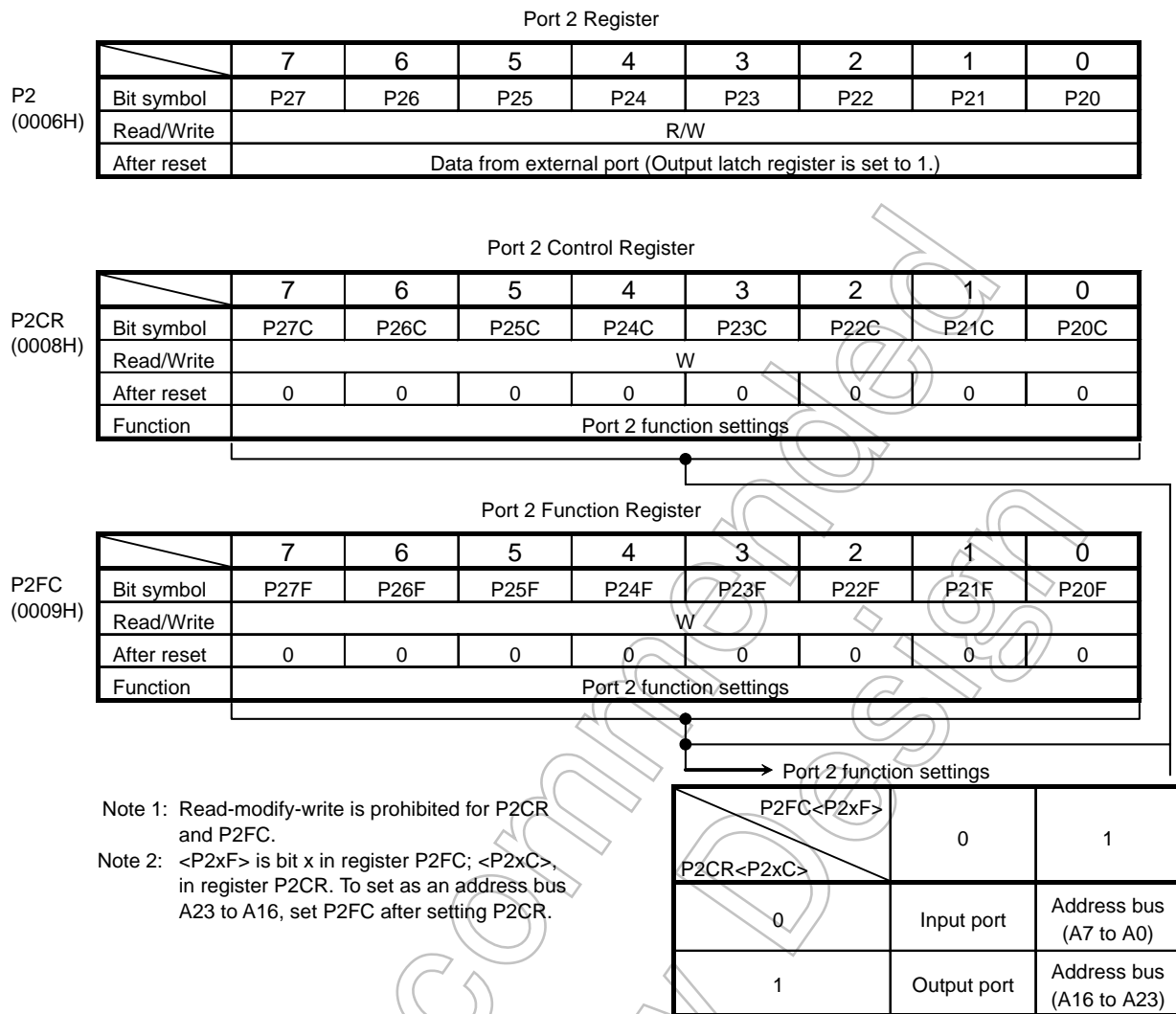

Figure 3.5.7 Register for Port 2

3.5.4 Port 3 (P30 to P37)

Port 3 is an 8-bit general-purpose I/O port. I/O can be set on a bit basis, but note that P30 and P31 are used for output only. I/O is set using control register P3CR and function register P3FC. Resetting set all bits of output latch P3 to "1", and control register P3CR (Bits 0 and 1 are unused), and function register P3FC to "0". Resetting also outputs 1 from P30 and P31, sets P32 to P37 to input mode, and connects a pull-up resistor.

In addition to functioning as a general-purpose I/O port, Port 3 also functions as an I/O for the CPU's control/status signal.

When P30 pin is defined as \overline{RD} signal output mode ($\langle P30F \rangle = 1$), clearing the output latch register $\langle P30 \rangle$ to 0 outputs the \overline{RD} strobe (used for the pseudo static RAM) from the P30 pin even when the internal address area is accessed.

If the output latch register $\langle P30 \rangle$ remains 1, the \overline{RD} strobe signal is output only when the external address area is accessed.

Not Recommended
for New Design

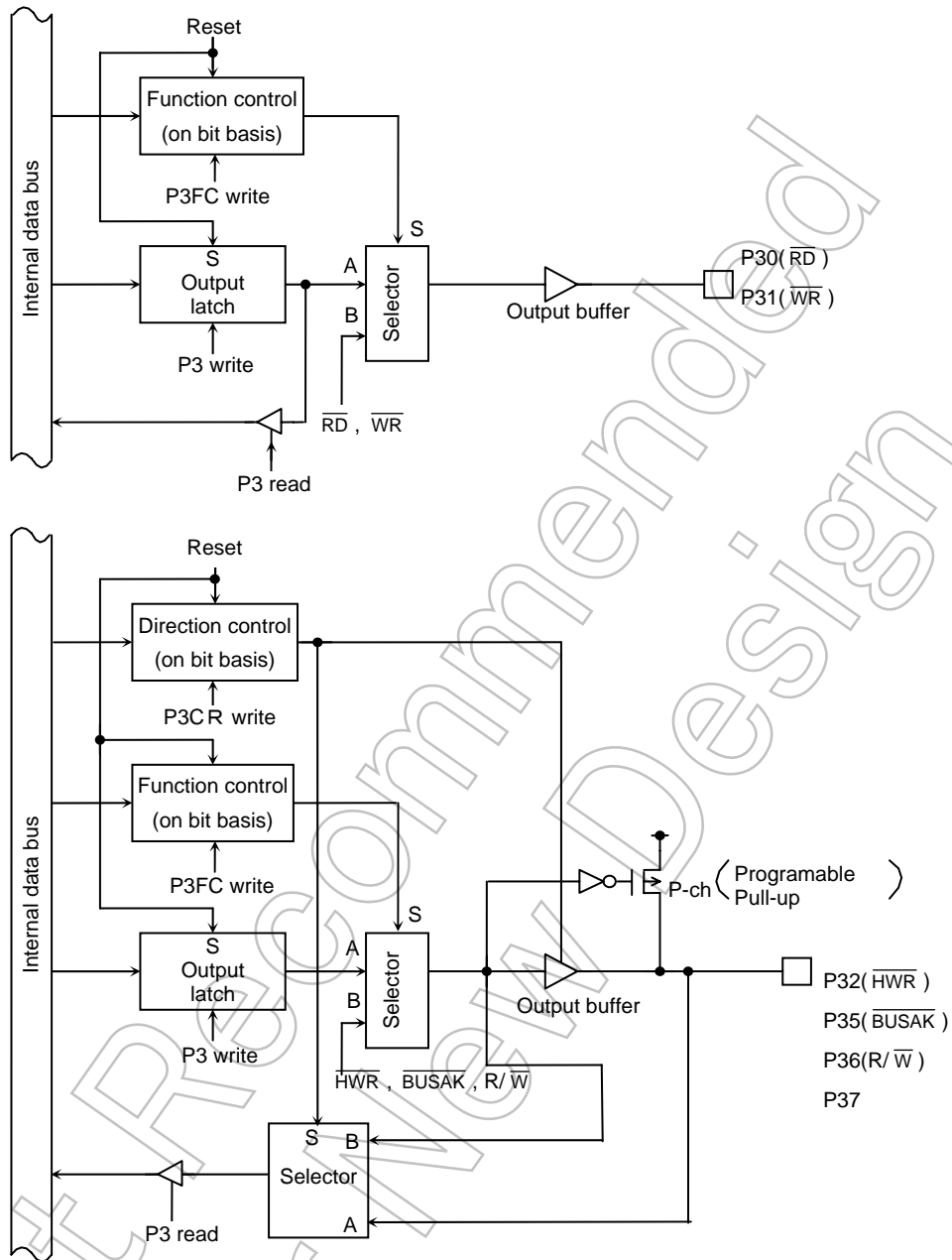

Figure 3.5.8 Port 3 (P30, P31, P32, P35, P36, P37)

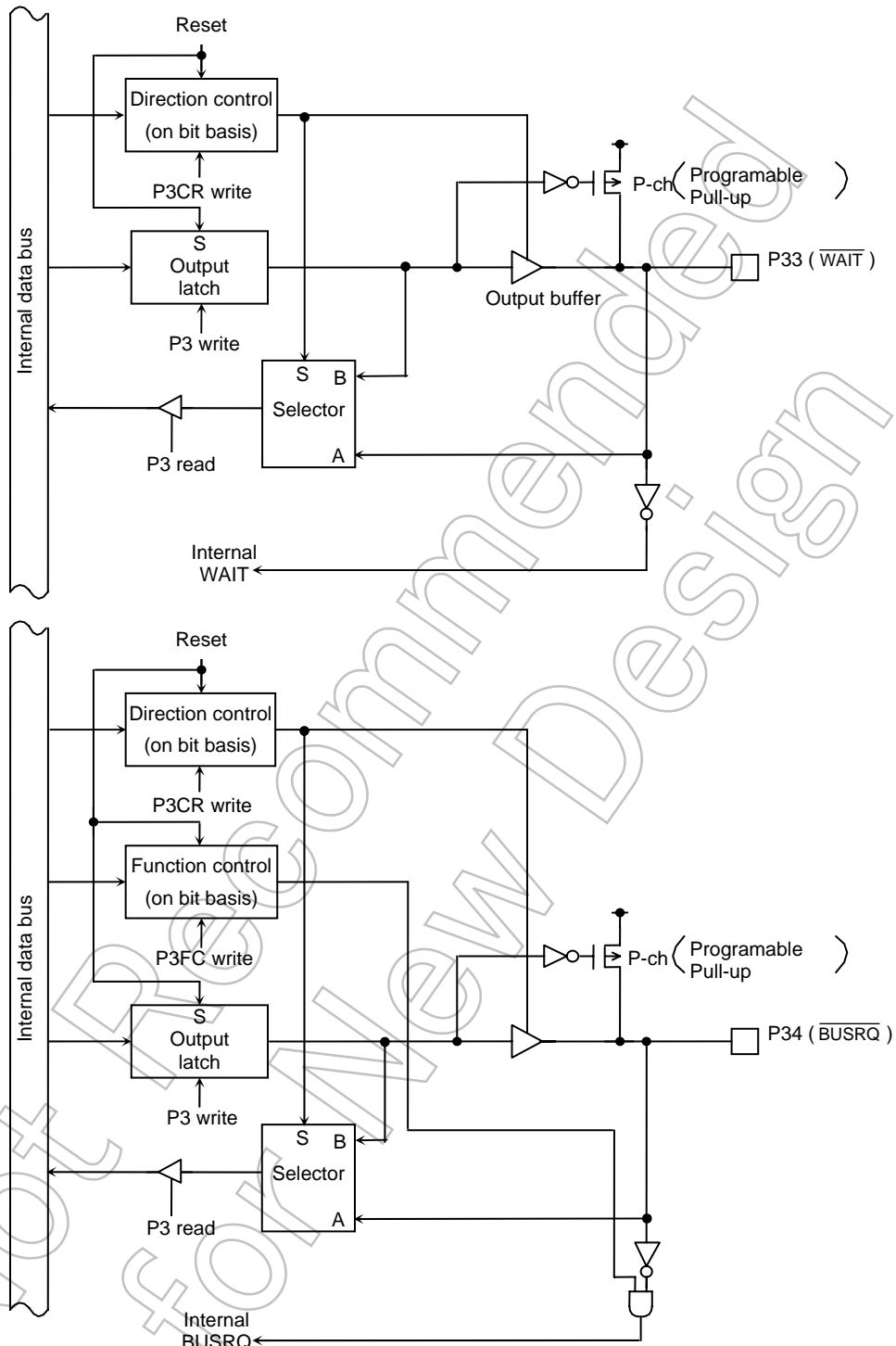

Figure 3.5.9 Port 3 (P33, P34)

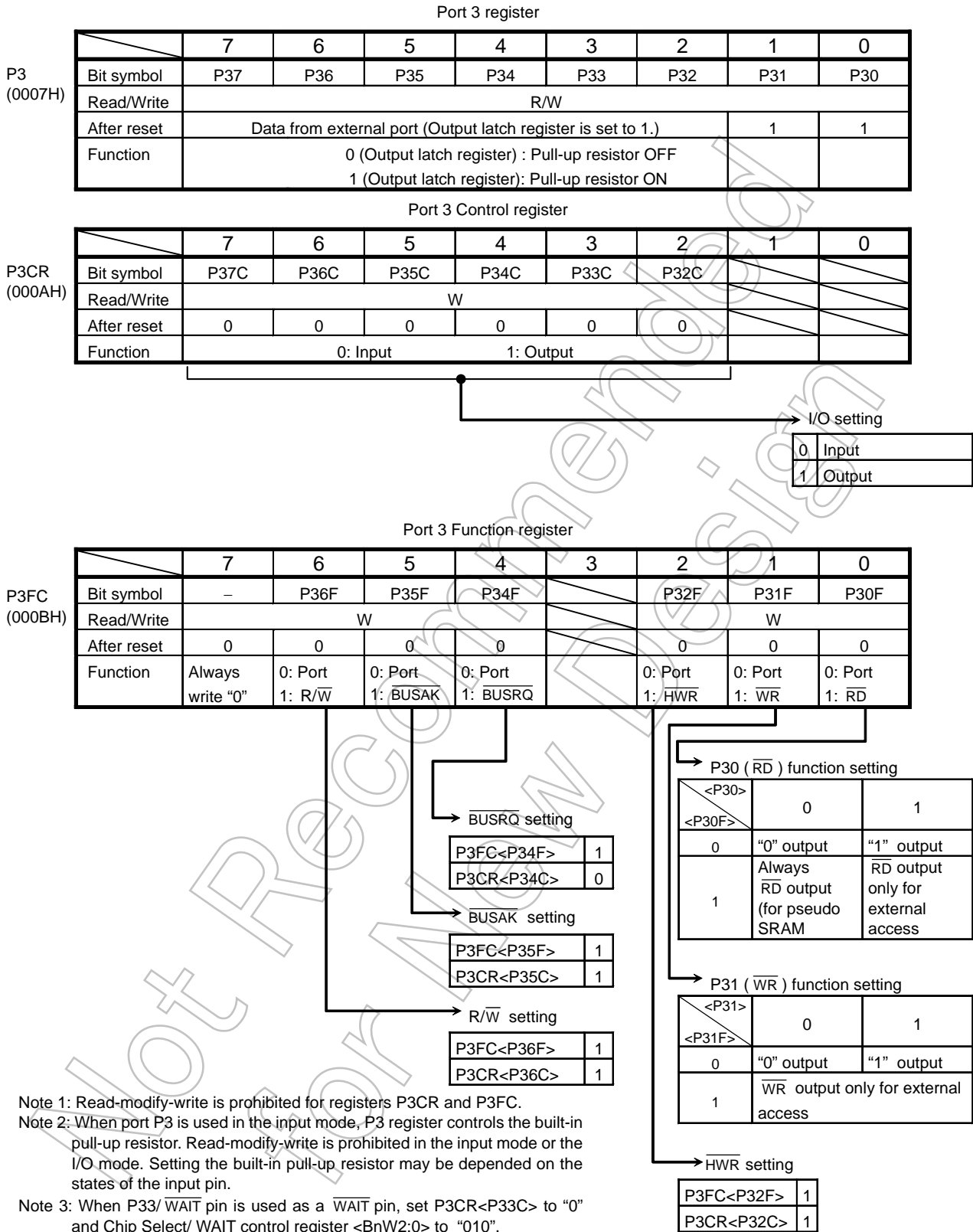

Figure 3.5.10 Register for Port 3

3.5.5 Port 4 (P40~P43)

Port 4 is a 4-bit general-purpose I/O port. Each bit can be set individually for input or output using the control register P4CR and function register P4FC. Resetting, set P40 to P43 of output register to "1", the control register P4CR and function register P4FC reset to "0" and sets port 4 to input mode with pull-up resistor.

In addition to functioning as a general-purpose I/O port, port 4 can also function as chip select output signal ($\overline{CS0}$ to $\overline{CS3}$).

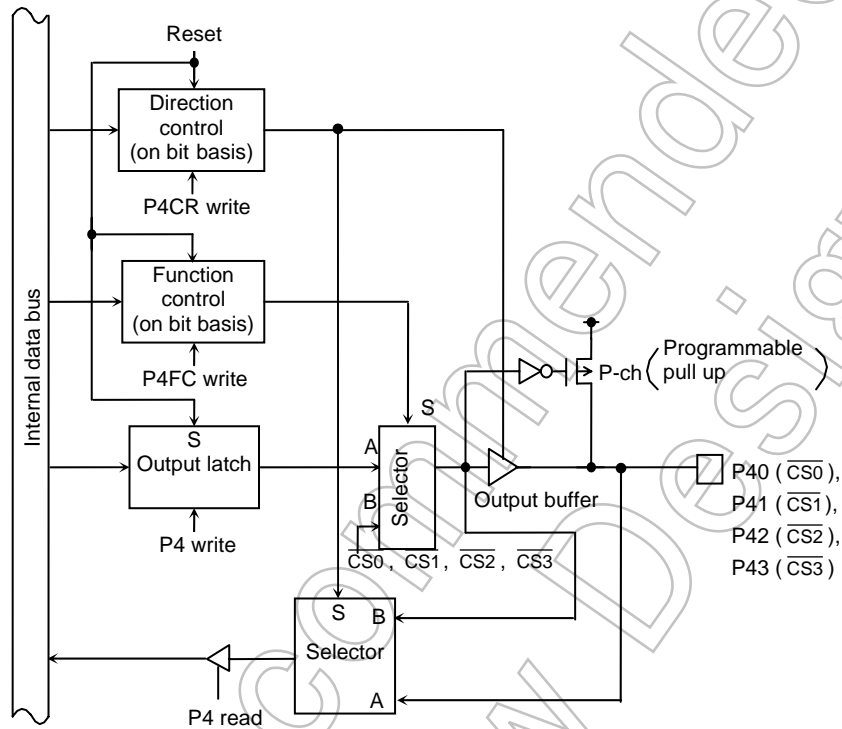
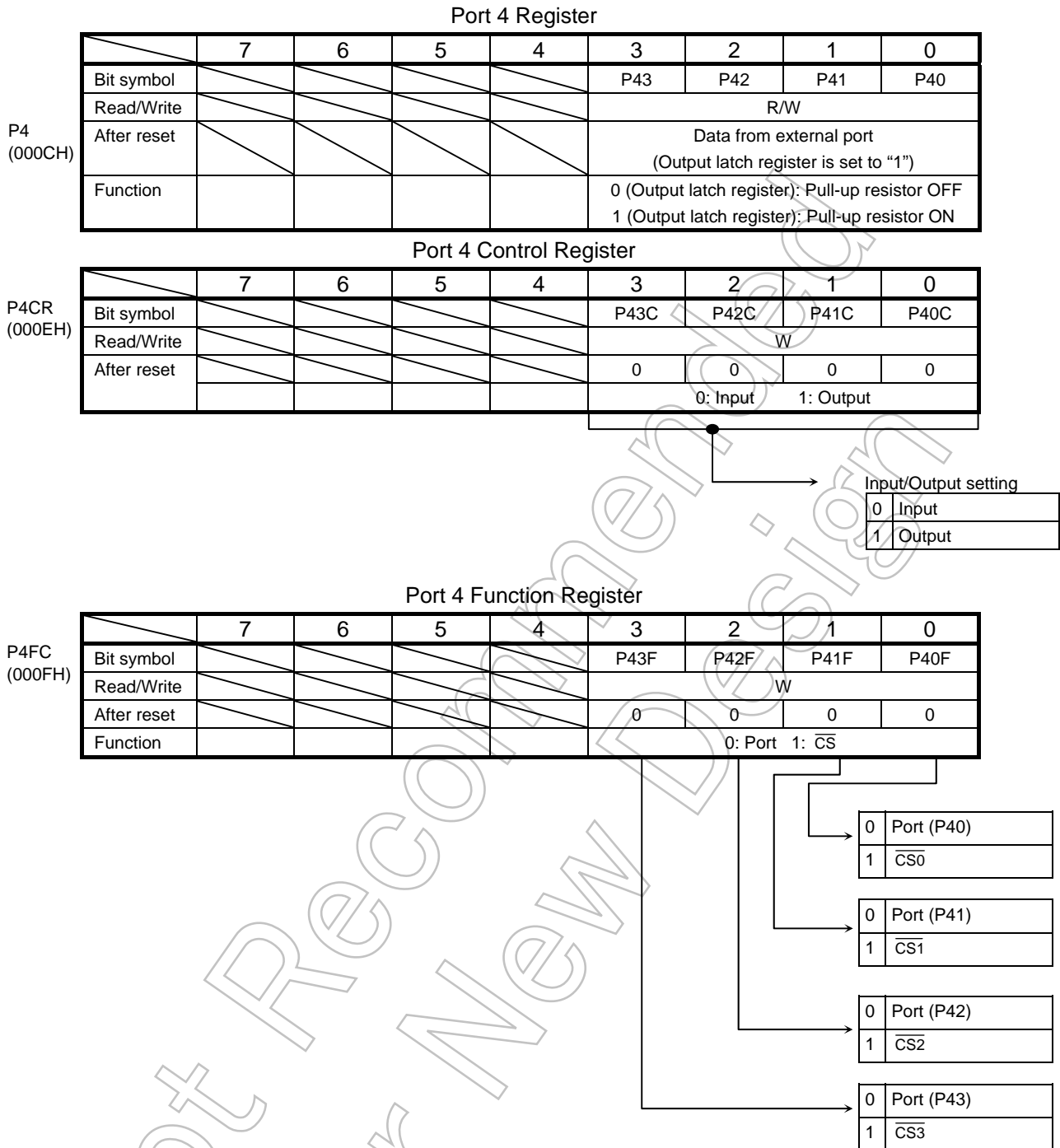

Figure 3.5.11 Port4



- Note 1: Read-modify-write instructions are prohibited for registers, P4CR and P4FC.
- Note 2: When port 4 is used in Input mode, the P4 register controls the internal pull-up resistor. Read-modify-write instruction is prohibited in Input mode or I/O mode. Setting the internal pull-up resistor may be depend on the states of the input pin.
- Note 3: When output chip select signal ($\overline{CS0}$ to $\overline{CS3}$), set bit of control register P4CR to "1" after set bit of function register P4FC to "1".
- Note 4: Output latch register is set to "1", and pull-up resistor is connected.

Figure 3.5.12 Register for Port 4

3.5.6 Port 5 (P50 to P57)

Port 5 is an 8-bit input port and can also be used as the analog input pin for the AD converter. P53 can also be used as AD trigger input pin for AD converter.

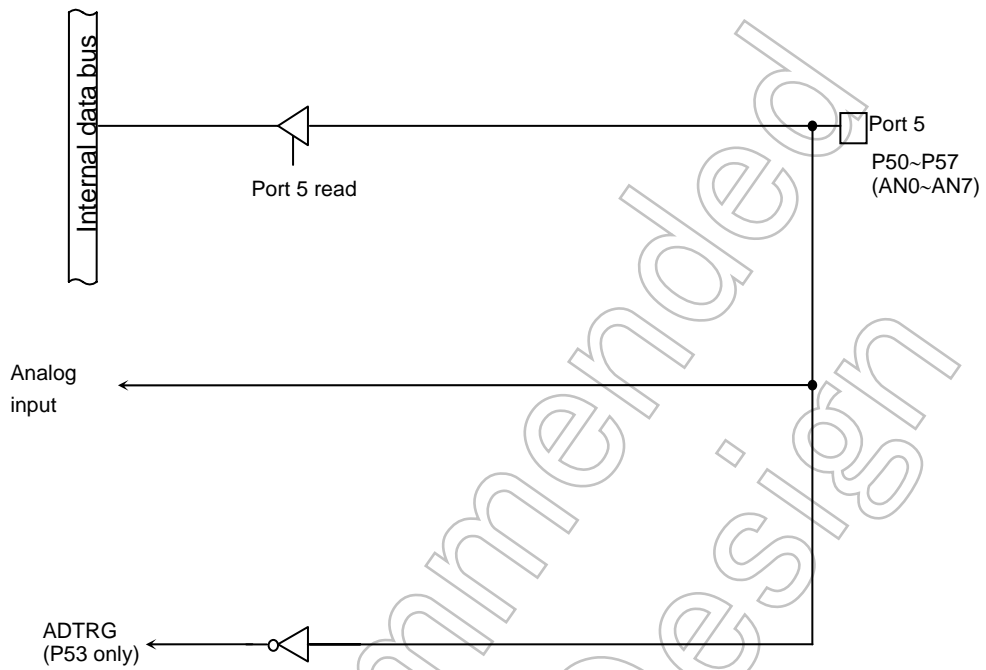

Figure 3.5.13 Port 5

Port 5 Register

	7	6	5	4	3	2	1	0
P5 (000DH)	P57	P56	P55	P54	P53	P52	P51	P50
Read/Write	R							
After reset	Data from external port							

Figure 3.5.14 Register for Port 5

Note: The input channel selection of AD converter and the permission of AD trigger input of P53 set by AD converter mode register ADMOD1.

3.5.7 Port 6 (P60 to P66)

Port 6 are 7-bit general-purpose I/O ports. Resetting set to input port. All bits of output latch register P6 are set to “1”.

In addition to functioning as an I/O port, port 6 can also function as input or output function of serial bus interface. This function enable each function by writing “1” to applicable bit of Port 6 function register P6FC.

Resetting, P6CR and P6FC reset to “0”, all bit set input port.

(1) Port 60 (SCK)

In addition to functioning as an I/O port, port 60 can also function as clock SCK I/O port in SIO mode of serial bus interface.

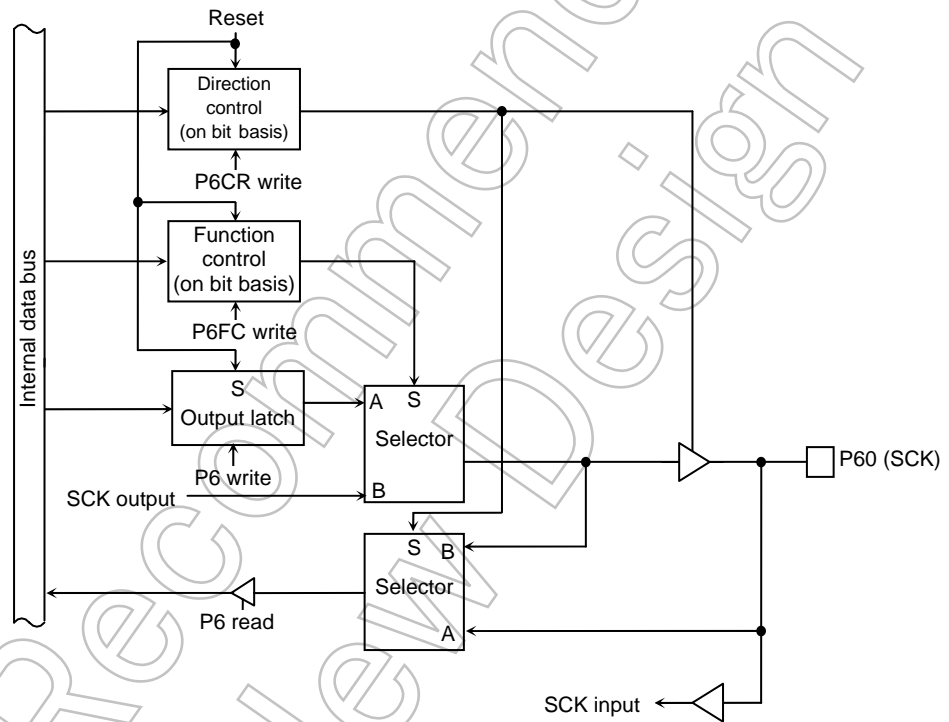

Figure 3.5.15 Port 60

(2) Port 61 (SO/SDA)

In addition to functioning as an I/O port, port 61 can also function as data SDA I/O port in I²C mode or data SO output pin in SIO mode of serial bus interface.

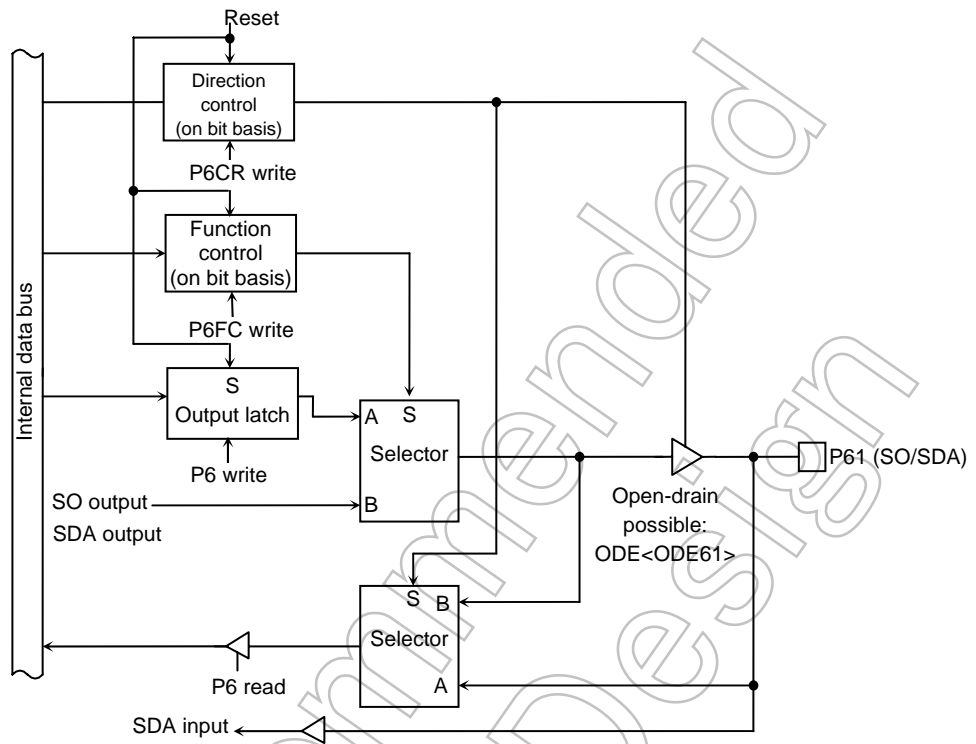

Figure 3.5.16 Port 61

Not Recommended for New Design

(3) Port 62 (SI/SCL)

In addition to functioning as an I/O port, port 62 can also function as data receiving pin in SIO mode or clock SCL I/O pin in I²C bus mode of serial bus interface.

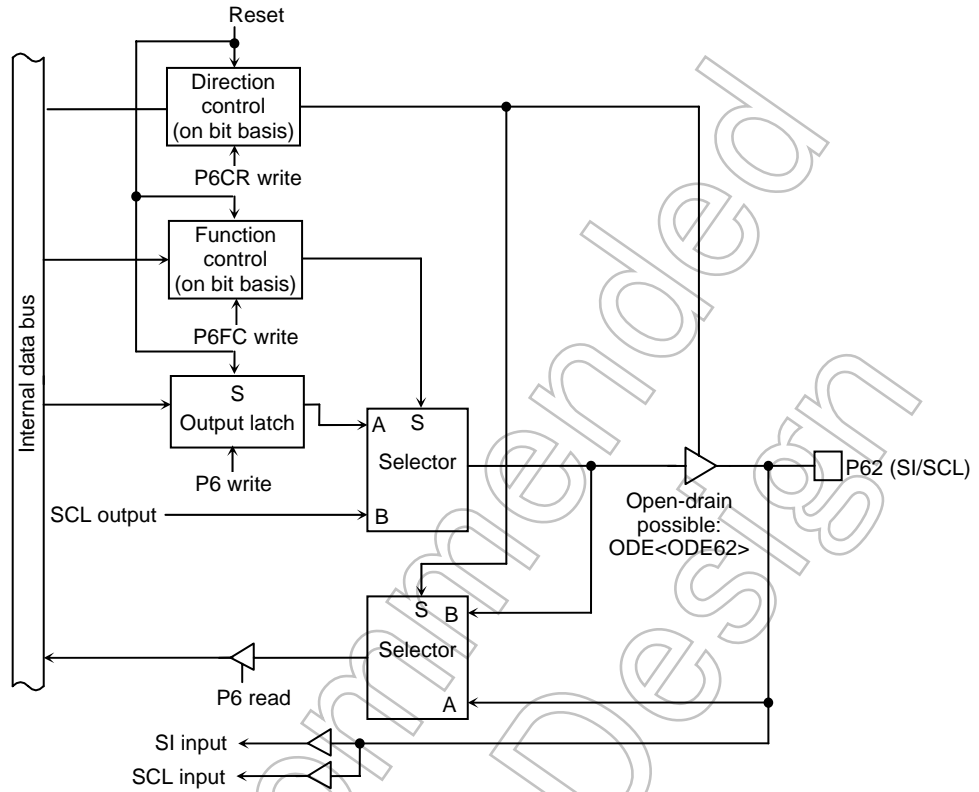

Figure 3.5.17 Port 62

Not Recommended for New Design

(4) Port 63 (INT0)

In addition to functioning as an I/O port, port 63 can also function as INT0 input pin of external interrupt.

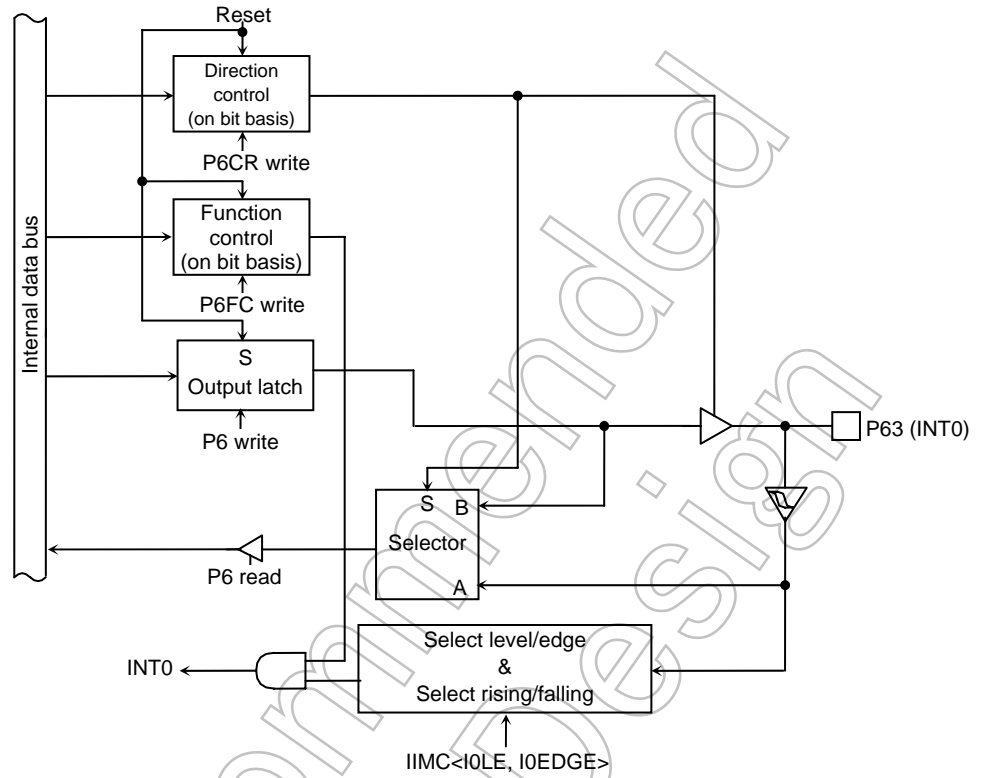

Figure 3.5.18 Port 63

Not Recommended for New

(5) Port 64 (SCOUT)

In addition to functioning as an I/O port, port 64 can also function as SCOUT output pin for outputs internal clock.

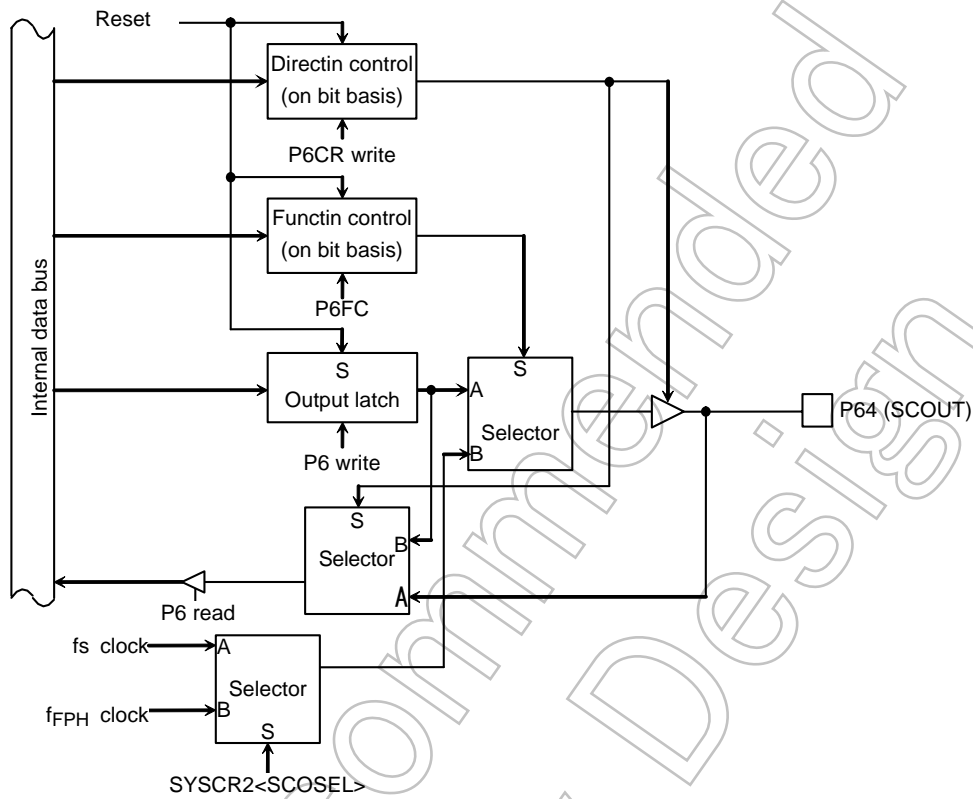

Figure 3.5.19 Port 64

(6) Port 65, 66

Port 65 and 66 functions as input or output ports.

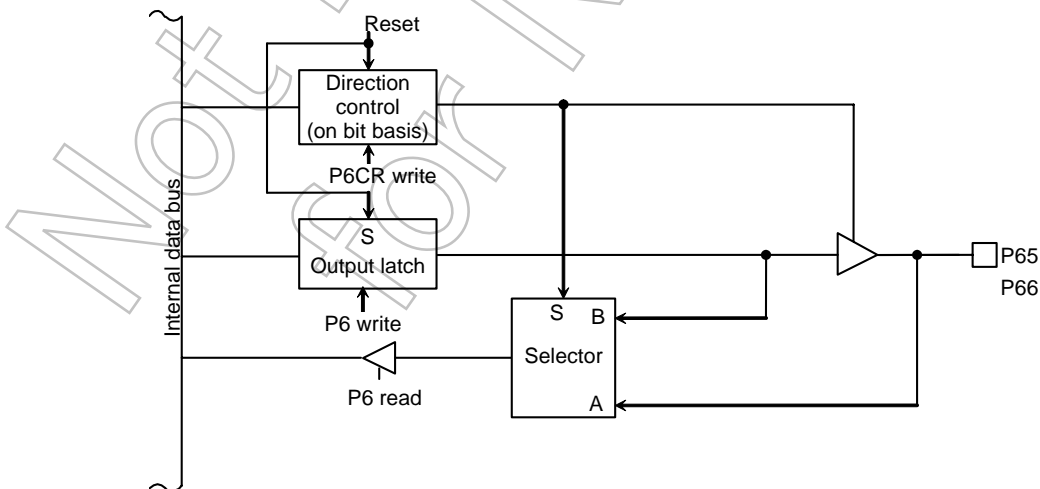

Figure 3.5.20 ポート 65, 66

Port 6 Registers

	7	6	5	4	3	2	1	0
P6 (0012H)	Bit symbol	P66	P65	P64	P63	P62	P61	P60
	Read/Write	R/W						
	After reset	Data from external port (Output latch register is set to "1")						

Port 6 Control Register

	7	6	5	4	3	2	1	0
P6CR (0014H)	Bit symbol	P66C	P65C	P64C	P63C	P62C	P61C	P60C
	Read/Write	W						
	After reset	0	0	0	0	0	0	0
	Function	0: Input 1: Output						

Port6 I/O setting

0	Input
1	Output

Port 6 Function Register

	7	6	5	4	3	2	1	0
P6FC (0015H)	Bit symbol			P64F	P63F	P62F	P61F	P60F
	Read/Write	W						
	After reset			0	0	0	0	0
	Function			0: Port 1: SCOUT output	0: Port 1: INT0 input	0: Port 1: SCL output	0: Port 1: SDA/SO output	0: Port 1: SCK output

P60 SCK output setting

P6FC<P60F>	1
P6CR<P60C>	1

P61 SDA/SO output setting

P6FC<P61F>	1
P6CR<P61C>	1

P62 SCL output setting

P6FC<P62F>	1
P6CR<P62C>	1

P63 INT0 input setting

P6FC<P63F>	1
P6CR<P63C>	0

P64 SCOUT output setting

P6FC<P64F>	1
P6CR<P64C>	0

Note: Read-modify-write instructions are prohibited for registers P6CR and P6FC.

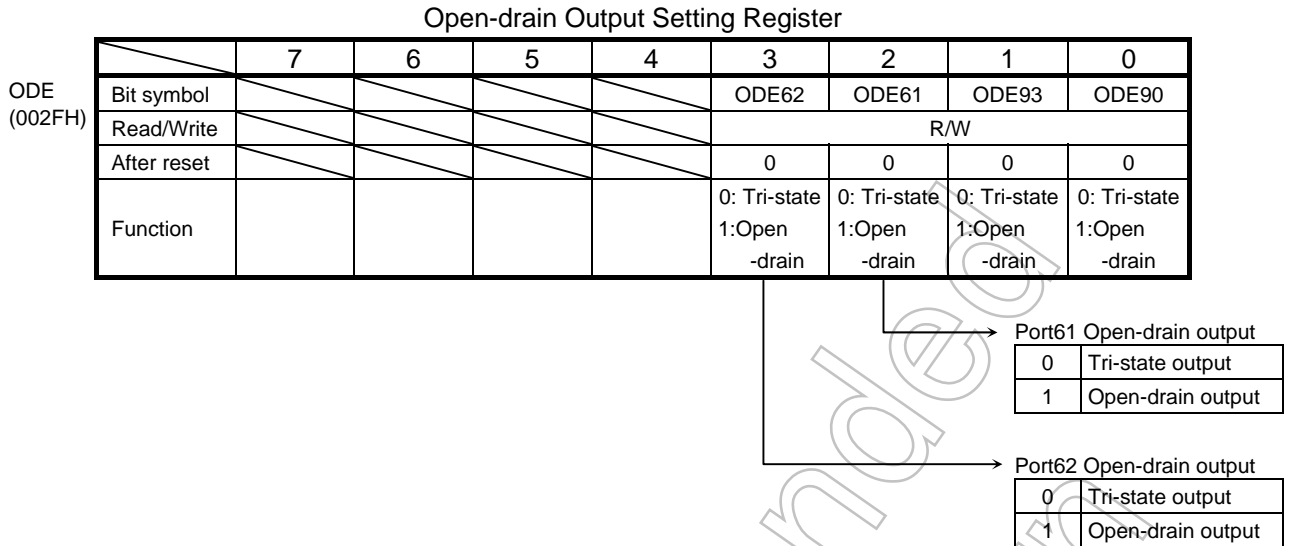

Figure 3.5.21 Register for Port 6

Not Recommended for New Designs

3.5.8 Port 7 (P70 to P75)

Port 7 is a 6-bit general-purpose I/O port. Resetting set to input port.

In addition to functioning as a I/O port, port 70 and 73 can also function as clock input pin TA0IN, TA4IN of 8-bit timer 0, 4 and port 71, 72, 74 and 75 can also function 8-bit timer output pin TA1OUT, TA3OUT, TA5OUT and TA7OUT. This timer output function enable each function by writing "1" to applicable bit of Port 7 function register P7FC.

Resetting, P7CR and P7FC reset to "0", all bit set input port.

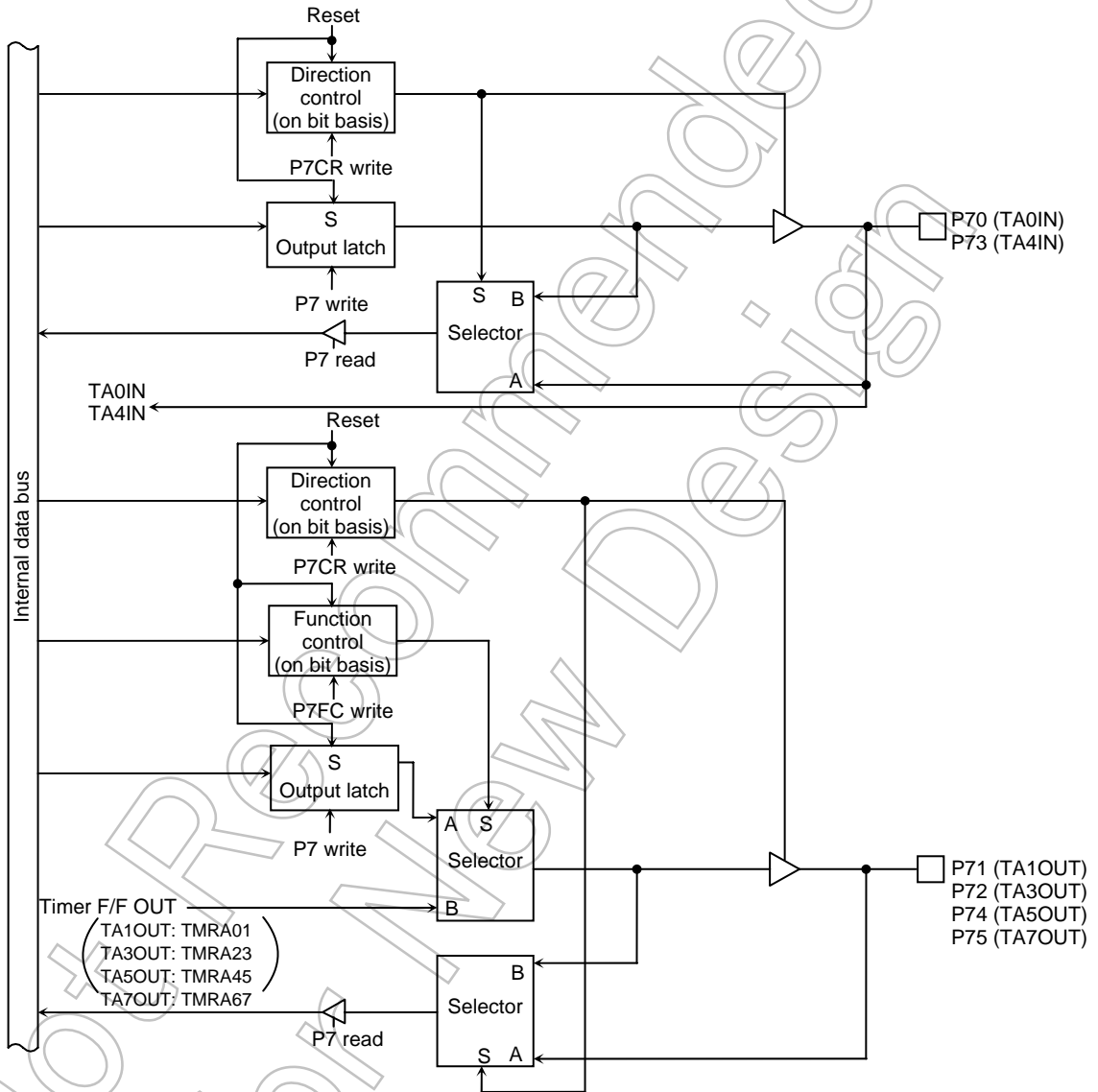
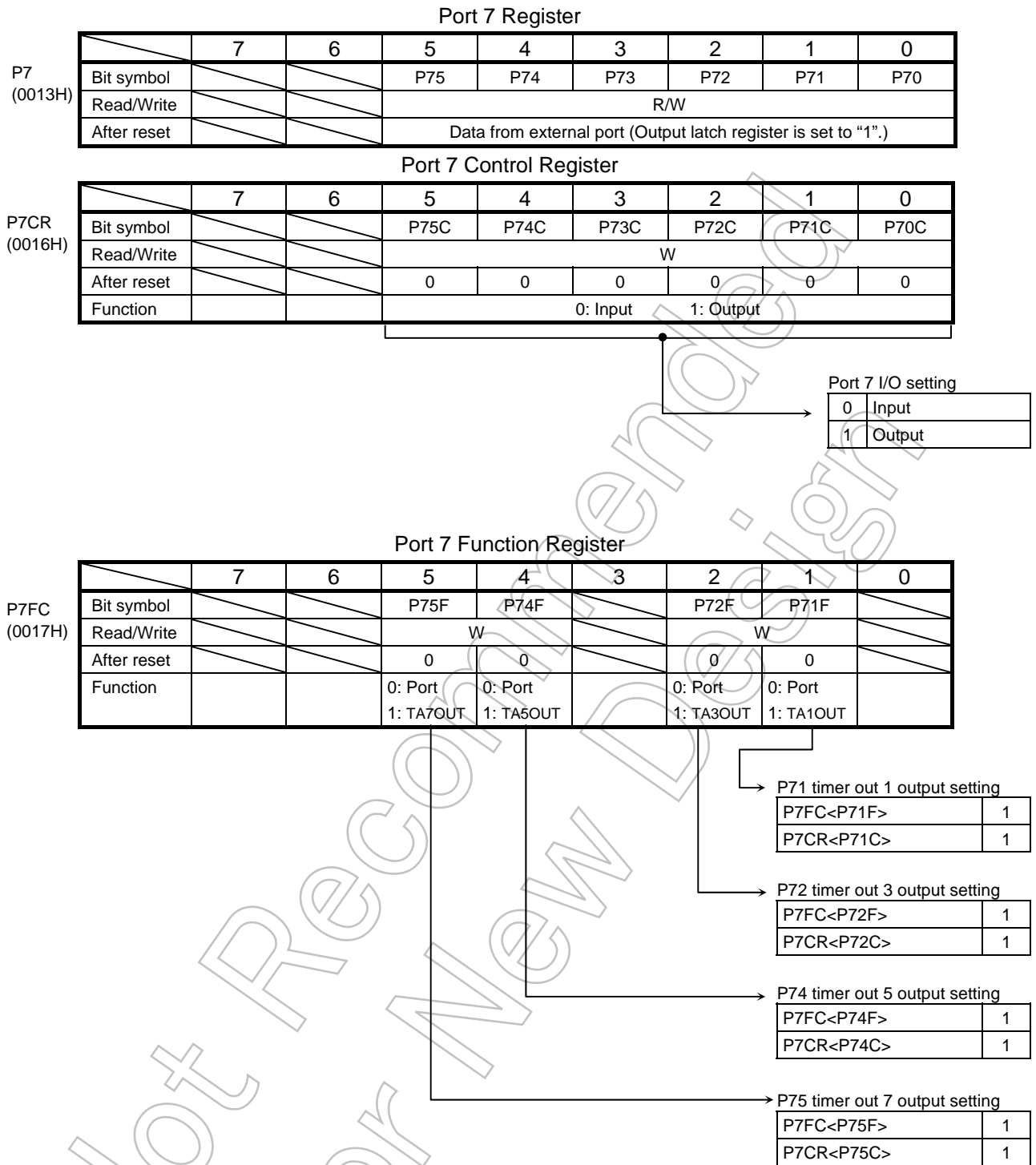

Figure 3.5.22 Port 7



Note 1: Read-Modify-Write instructions are prohibited for the registers P7CR and P7FC.

Note 2: P70/TA0IN and P73/TA4IN pin does not have a register changing Port/Function.

For example, when it is used as an input port, the input signal is inputted to 8-bit timer.

Figure 3.5.23 Register for Port 7

3.5.9 Port 8 (P80 to P87)

Port 8 is an 8-bit general-purpose I/O port. Resetting set to input port. All bits of output latch register P8 are set to “1”.

In addition to functioning as an I/O port, port 8 can also function as clock input of 16-bit timer, output of 16-bit timer F/F and input function of INT5 to INT8. This function enable each function by writing “1” to applicable bit of port 8 function register P8FC.

Resetting, P8CR and P8FC reset to “0”, all bits set input port.

(1) P80 to P87

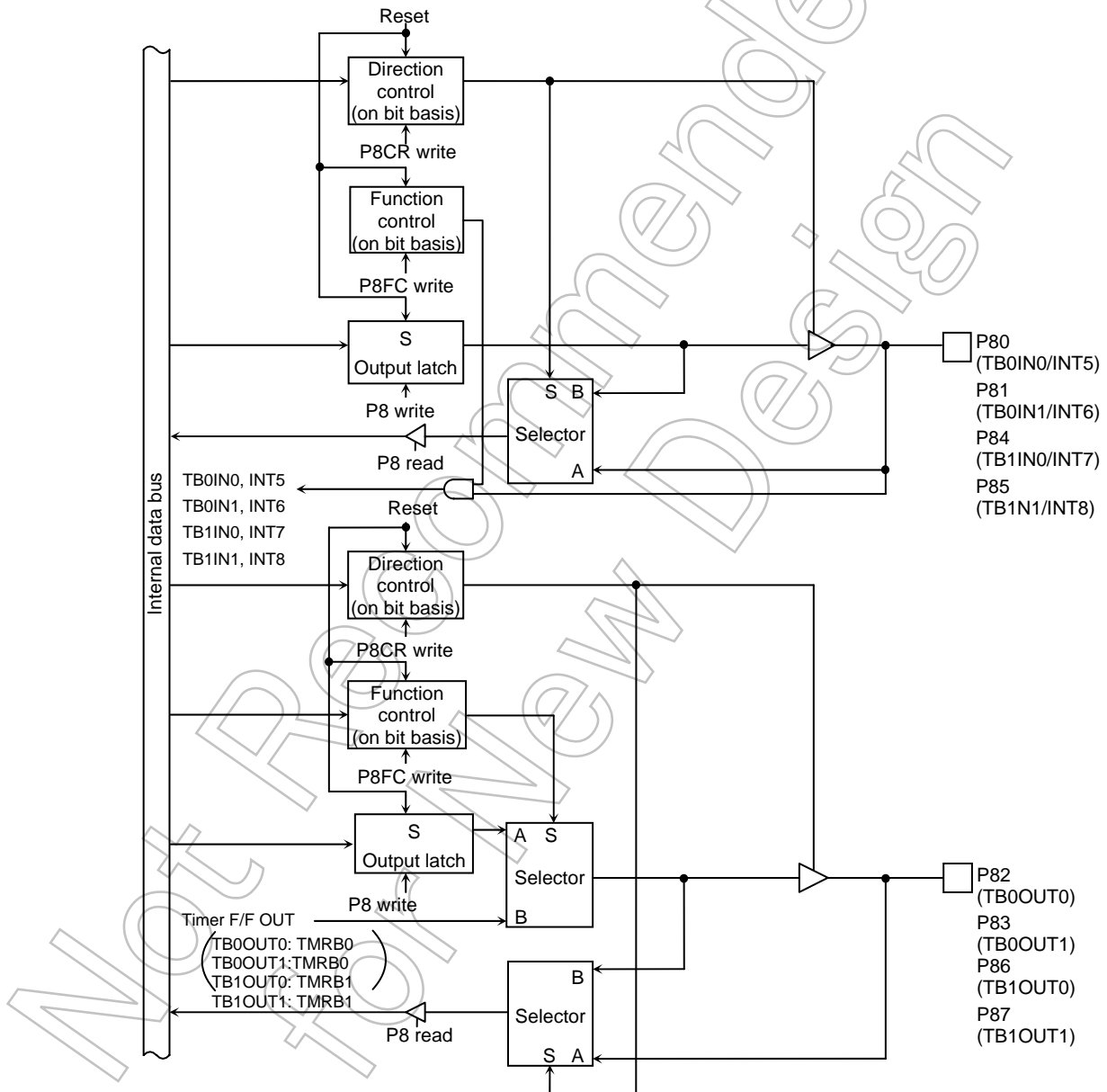
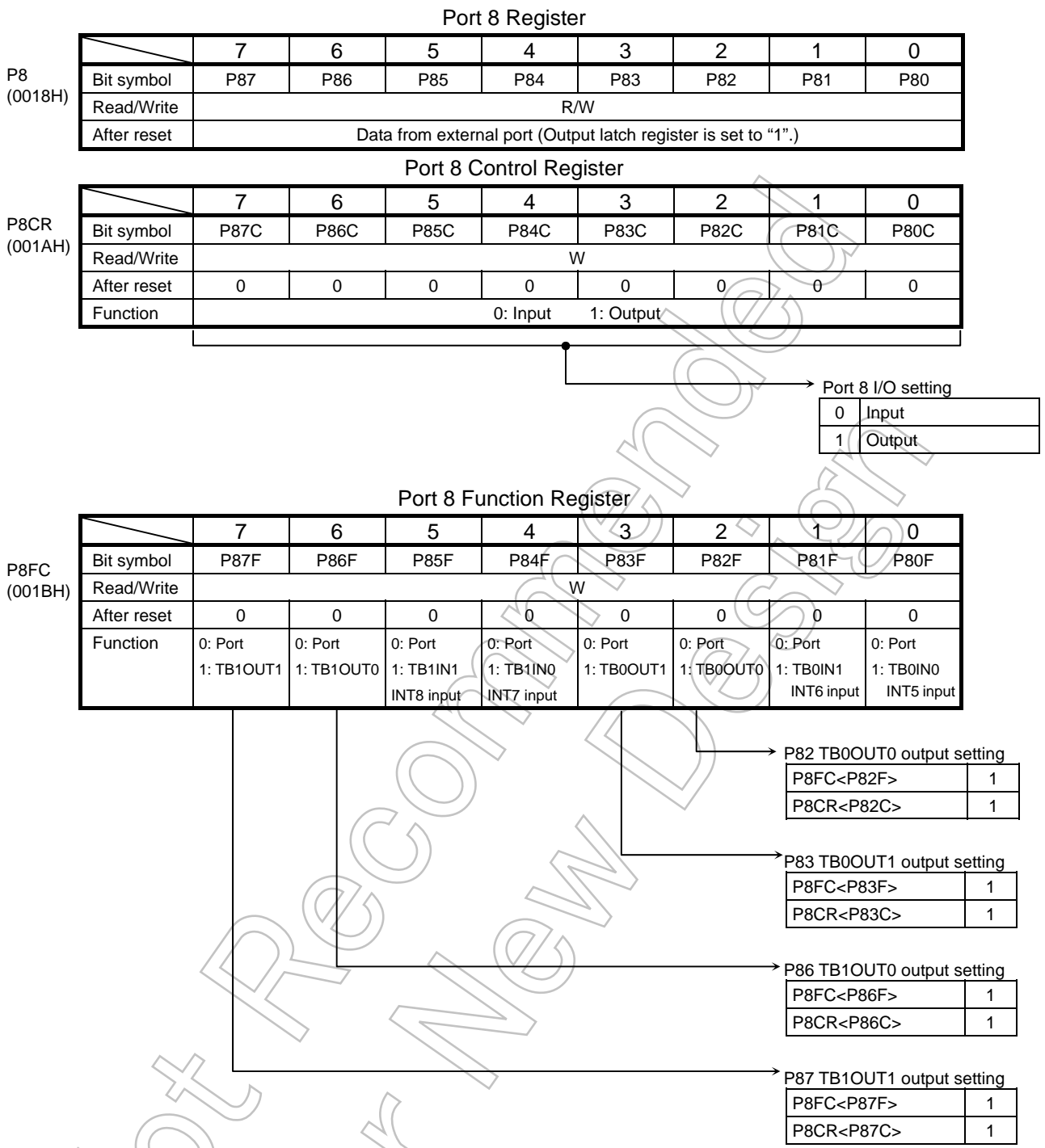

Figure 3.5.24 Port 8 (P80 to P87)



Note: Read-modify-write instructions are prohibited for registers P8CR and P8FC.

Figure 3.5.25 Register for Port 8

3.5.10 Port 9 (P90 to P97)

Ports 90 to 95

Ports 90 to 95 are a 6-bit general-purpose I/O port. Resetting set to input port. All bits of output latch register are set to "1".

In addition to functioning as a I/O port, port 90 to 95 can also function as I/O of SIO0, SIO1. This function enable each function by writing "1" to applicable bit of port 9 function register P9FC.

Resetting, P9CR and P9FC reset to "0", all bits set input port.

Ports 96 to 97

Ports 96 to 97 are a 2-bit general-purpose I/O port. Case of output port, this is open drain output. Resetting, output latch register and control register set to "1", and set to "High-Z" (High impedance).

In addition to functioning as a I/O port, ports 96 to 97 can also function as low-frequency oscillator connection pin (XT1 and XT2) during using low speed clock function. Therefore, dual clock function can use by setting of system clock control registers SYSCR0 and SYSCR1.

(1) Ports 90 and 93 (TXD0 and TXD1)

In addition to functioning as an I/O port, Ports 90 and 93 can also function as TXD output pin of serial channel.

And P90 and P93 have a programmable open-drain function which can be controlled by the ODE<ODE90, 93> register.

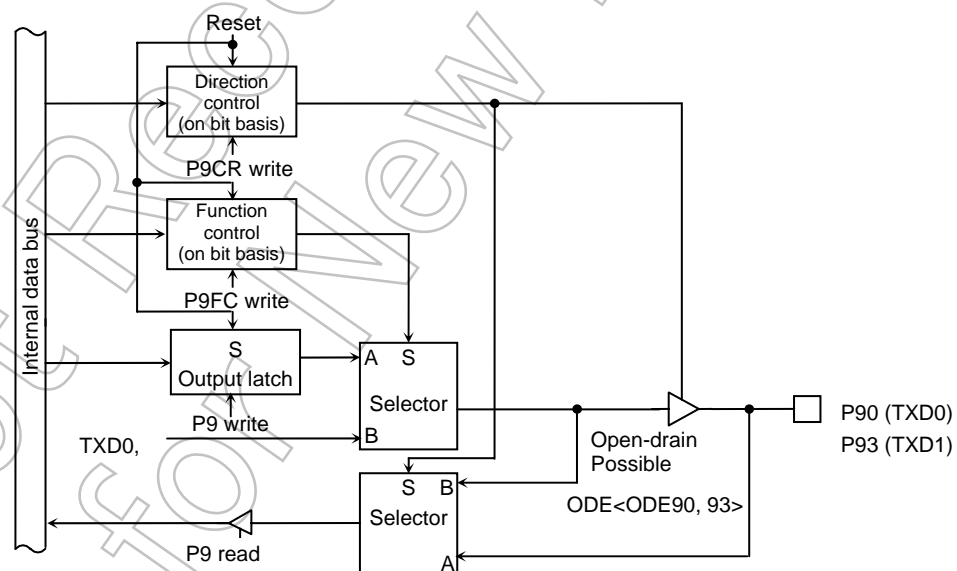

Figure 3.5.26 Ports 90 and 93

(2) Ports 91 and 94 (RXD0 and RXD1)

In addition to functioning as an I/O port, ports 91 and 94 can also function as RXD input pin of serial channel.

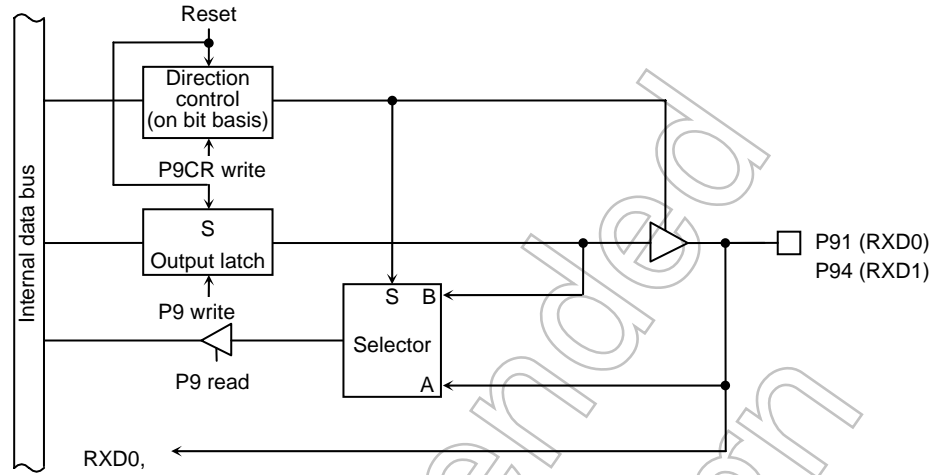

Figure 3.5.27 Ports 91 and 94

(3) Ports 92 and 95 ($\overline{CTS0}/SCLK0$, $\overline{CTS1}/SCLK1$)

In addition to functioning as an I/O port, ports 92 and 95 can also function as \overline{CTS} input pin or SCLK I/O pin of serial channel.

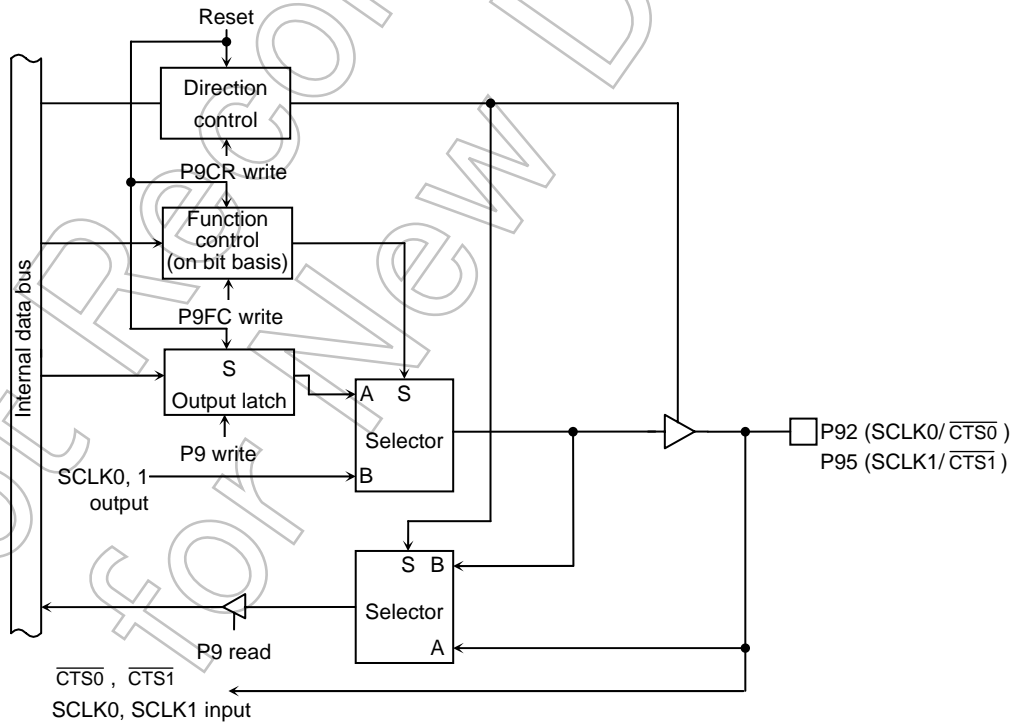

Figure 3.5.28 Port 92, 95

(4) Ports 96 (XT1) and 97 (XT2)

In addition to functioning as an I/O port, ports 96 and 97 can also function as low frequency oscillator connection pins.

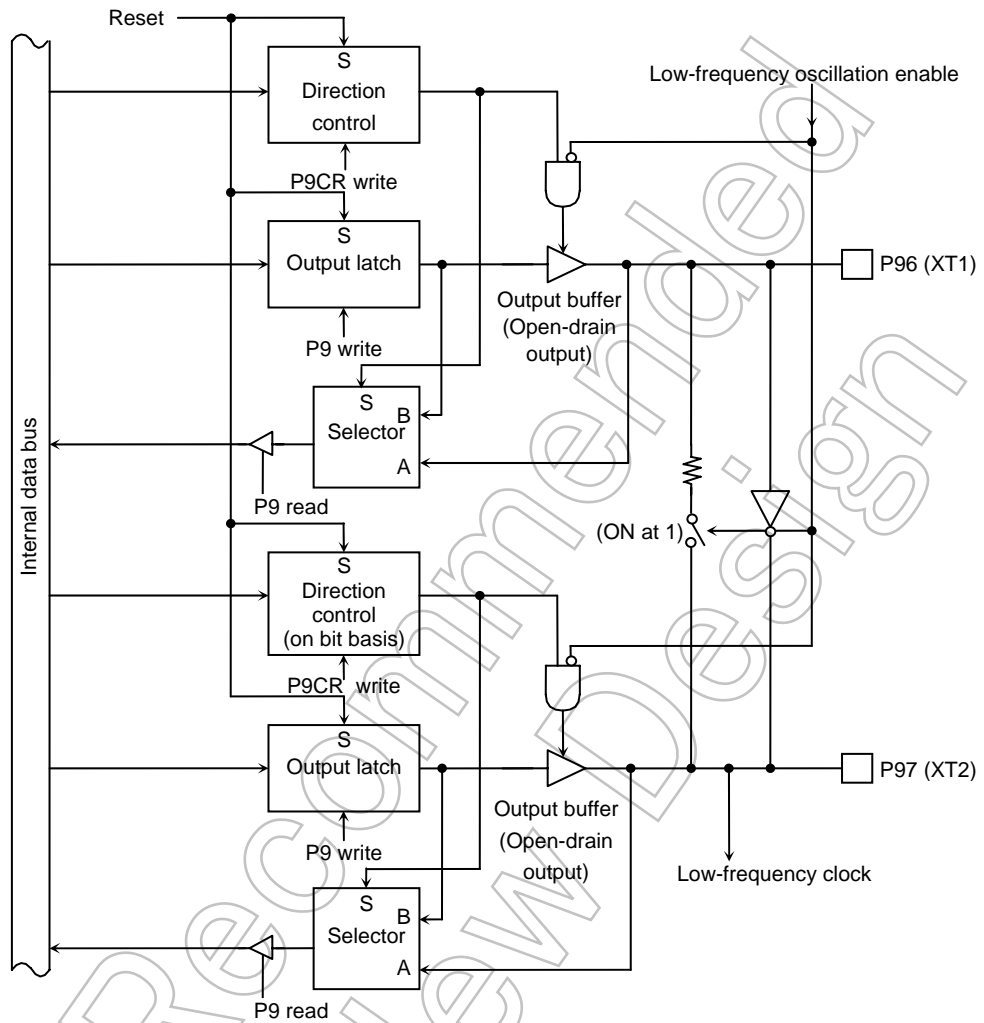

Figure 3.5.29 Ports 96 and 97

Not for use

Port 9 Registers

	7	6	5	4	3	2	1	0	
P9 (0019H)	Bit symbol	P97	P96	P95	P94	P93	P92	P91	P90
	Read/Write	R/W							
	After reset	1	1	Data from external port (Output latch register is set to "1".)					

Port 9 Control Register

	7	6	5	4	3	2	1	0	
P9CR (001CH)	Bit symbol	P97C	P96C	P95C	P94C	P93C	P92C	P91C	P90C
	Read/Write	W							
	After reset	1	1	0	0	0	0	0	0
	Function	0: Input 1: Output							

Port9 I/O setting

0	Input
1	Output

Note: Ports 96 and 97 are open-drain output pins.

Port 9 Function Register

	7	6	5	4	3	2	1	0
P9FC (001DH)	Bit symbol			P95F		P93F	P92F	P90F
	Read/Write			W		W		W
	After reset			0		0	0	0
	Function			0: Port 1: SCLK1 output		0: Port 1: TXD1	0: Port 1: SCLK0 output	0: Port 1: TXD0

P90 TXD0 output setting

P9FC<P90F>	1
P9CR<P90C>	1

P92 SCLK0 output setting

P9FC<P92F>	1
P9CR<P92C>	1

P93 TXD1 output setting

P9FC<P93F>	1
P9CR<P93C>	1

P95 SCLK1 output setting

P9FC<P95F>	1
P9CR<P95C>	1

Note 1: Read-modify-write instructions are prohibited for the registers P9CR and P9FC.

Note 2: When set TXD pin to open-drain output, write "1" to bit0 of ODE register (for TXD0 pin), or bit1 (for TXD1 pin). P91/RXD0 and P94/RXD1 pin does not have a register changing Port/Function. For example, when it is used as an input port, the input signal is inputted to SIO as serial receiving data.

Note 3: Low frequency oscillation circuit

To connect a low frequency resonator to ports 96 and 97, it is necessary to set a following procedure to reduce the consumption power supply.

(Case of resonator connection)

P9CR<P96C, P97C> = "11", P9<P96:97> = "00"

(Case of oscillator connection)

P9CR<P96C, P97C> = "11", P9<P96:97> = "10"

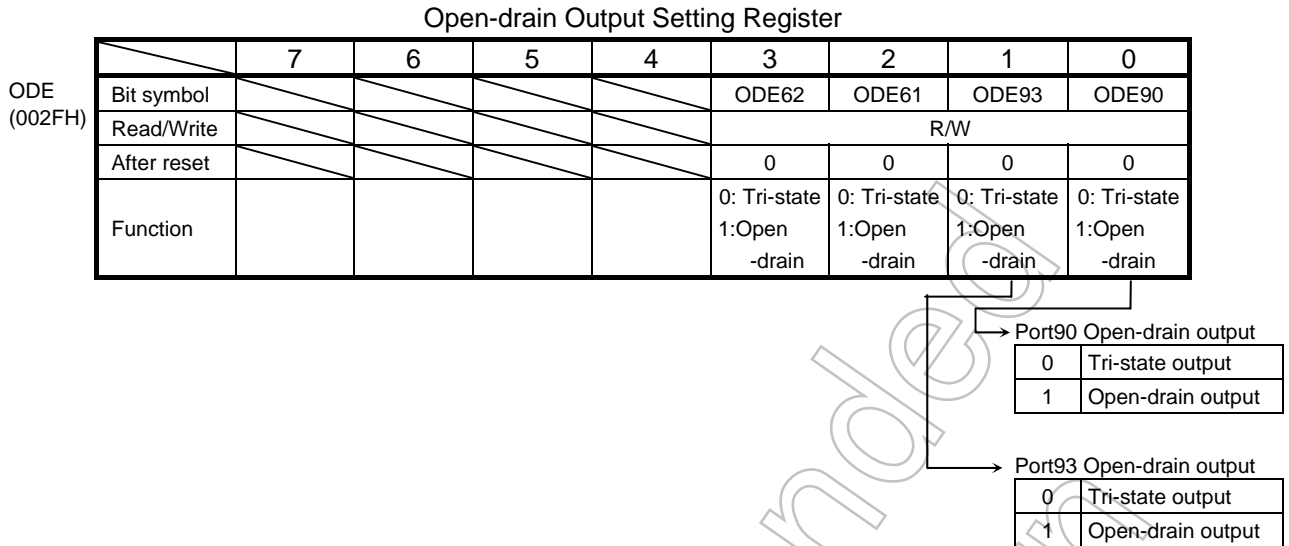

Figure 3.5.30 Register for Port 9

Not Recommended for New Designs

3.5.11 Port A (PA0~PA7)

Port A is an 8-bit general-purpose I/O port. I/Os can be set on a bit basis by control register PACR. After reset, PACR is reset to 0 and port A is set to an input port. Port A0 to A3 can also function as inputs for INT1 to INT4.

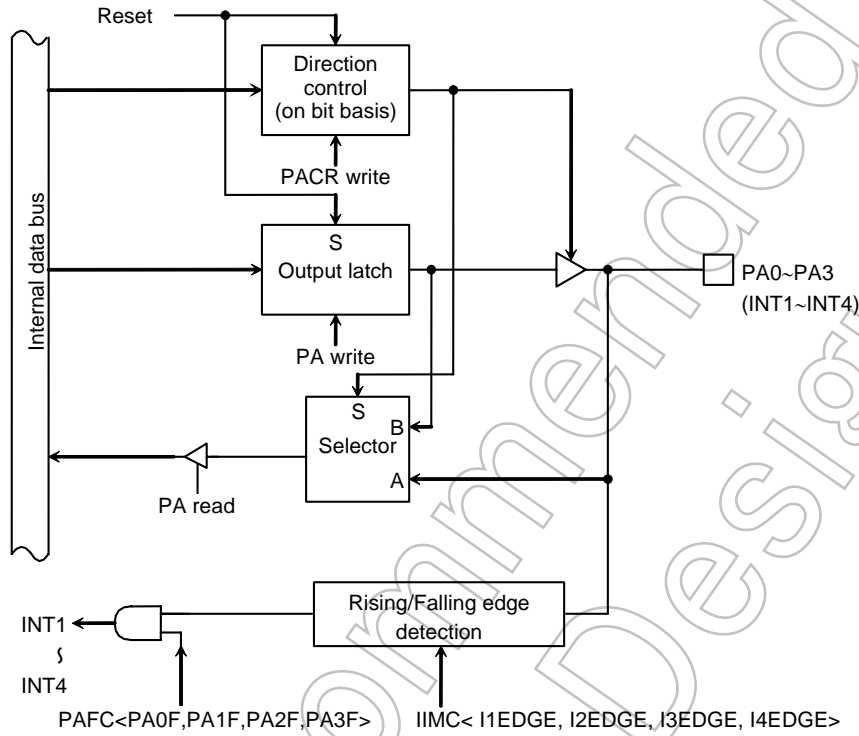

Figure 3.5.31 Port A0~A3

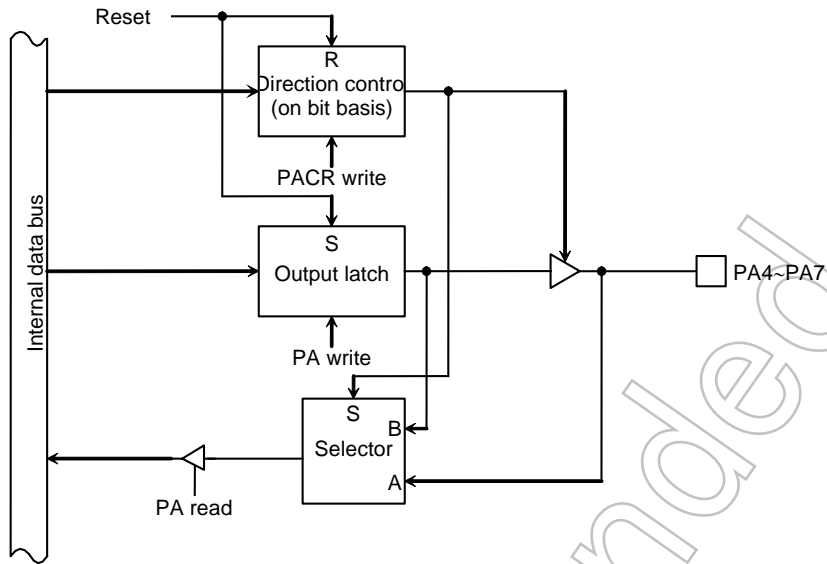
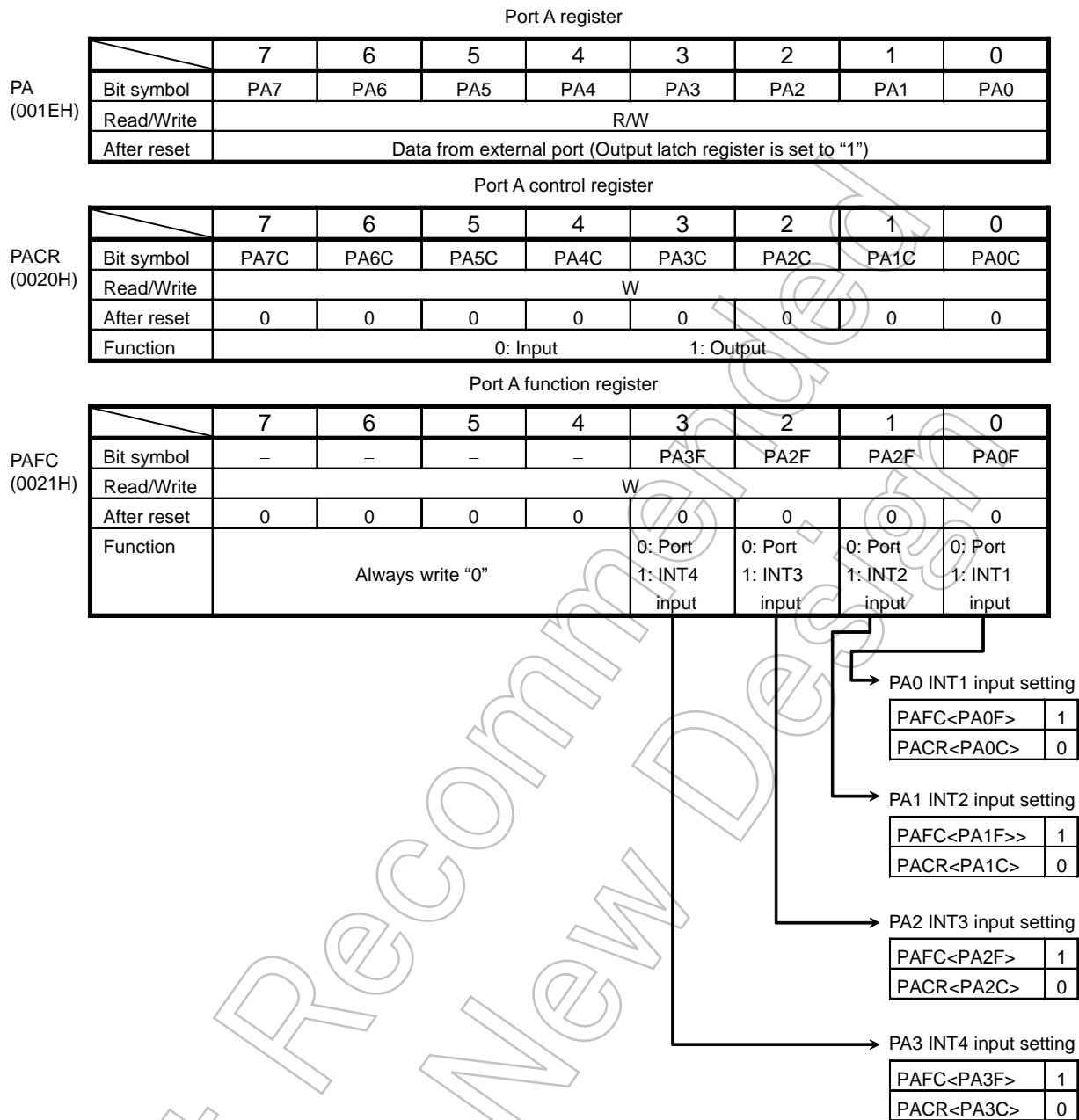

Figure 3.5.32 Port A4~A7

Not Recommended for New Design



Note: Read-modify-write is prohibited for registers PACR and PAFC.

Figure 3.5.33 Register for Port A

3.6 Chip Select/Wait Controller

On the TMP91FY42, four user-specifiable address areas (CS0 to CS3) can be set. The data bus width and the number of waits can be set independently for each address area (CS0 to CS3 and others).

The pins $\overline{CS0}$ to $\overline{CS3}$ (which can also function as port pins P40 to P43) are the respective output pins for the areas CS0 to CS3. When the CPU specifies an address in one of these areas, the corresponding $\overline{CS0}$ to $\overline{CS3}$ pin outputs the chip select signal for the specified address area (in ROM or SRAM). However, in order for the chip select signal to be output, the port 4 function register P4FC must be set. TMP91FY42 supports connection of external ROM and SRAM.

The areas CS0 to CS3 are defined by the values in the memory start address registers MSAR0 to MSAR3 and the memory address mask registers MAMR0 to MAMR3.

The chip select/wait control registers B0CS to B3CS and BEXCS should be used to specify the master enable/disable status the data bus width and the number of waits for each address area.

The input pin controlling these states is the bus wait request pin (\overline{WAIT}).

3.6.1 Specifying an Address Area

The CS0 to CS3 address areas are specified using the start address registers (MSAR0 to MSAR3) and memory address mask registers (MAMR0 to MAMR3).

At each bus cycle, a compare operation is performed to determine if the address on the specified a location in the CS0 to CS3 area. If the result of the comparison is a match, this indicates an access to the corresponding CS area. In this case, the $\overline{CS0}$ to $\overline{CS3}$ pin outputs the chip select signal and the bus cycle operates in accordance with the settings in chip select/wait control register B0CS to B3CS. (See 3.6.2 “Chip Select/Wait Control Registers”.)

(1) Memory start address registers

Figure 3.6.1 shows the memory start address registers. The memory start address registers MSAR0 to MSAR3 set the start addresses for the CS0 to CS3 areas. Set the upper 8 bits (A23 to A16) of the start address in <S23:16>. The lower 16 bits of the start address (A15 to A0) are permanently set to 0. Accordingly, the start address can only be set in 64-Kbyte increments, starting from 000000H. Figure 3.6.2 shows the relationship between the start address and the start address register value.

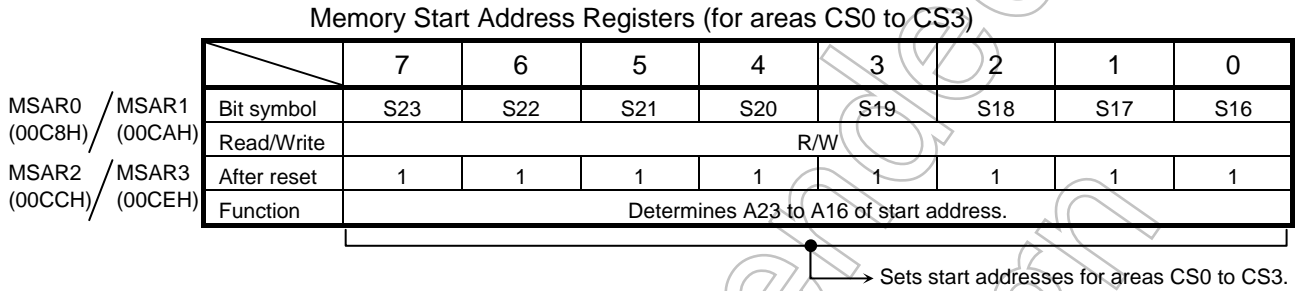

Figure 3.6.1 Memory Start Address Register

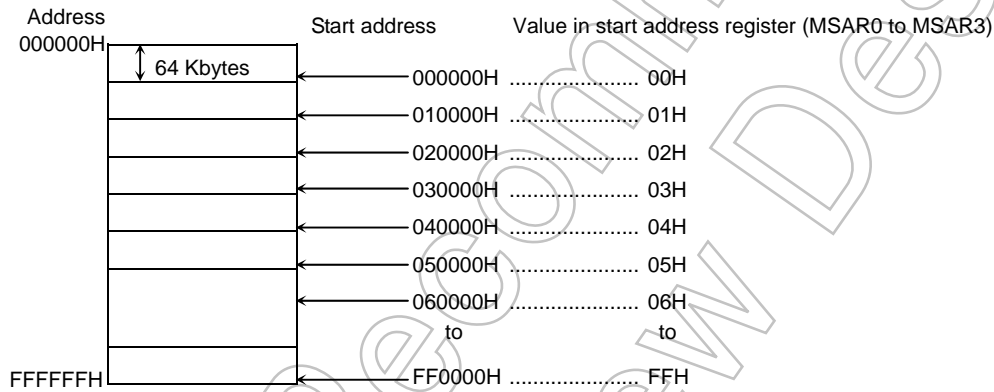

Figure 3.6.2 Relationship between Start Address and Start Address Register Value

(2) Memory address mask registers

Figure 3.6.3 shows the memory address mask registers. Memory address mask registers MAMR0 to MAMR3 are used to set the size of the CS0 to CS3 areas by specifying a mask for each bit of the start address set in memory start address registers MAMR0 to MAMR3. The compare operation used to determine if an address is in the CS0 to CS3 areas is only performed for bus address bits corresponding to bits set to 0 in these registers. Also, the address bits that can be masked by MAMR0 to MAMR3 differ between CS0 to CS3 areas. Accordingly, the size that can be each area is different.

Memory Address Mask Register (for CS0 area)

	7	6	5	4	3	2	1	0	
MAMR0 (00C9H)	Bit symbol	V20	V19	V18	V17	V16	V15	V14 to V9	V8
	Read/Write	R/W							
	After reset	1	1	1	1	1	1	1	1
	Function	Sets size of CS0 area 0: Used for address compare							

Range of possible settings for CS0 area size: 256 bytes to 2 Mbytes

Memory Address Mask Register (CS1)

	7	6	5	4	3	2	1	0	
MAMR1 (00CBH)	Bit symbol	V21	V20	V19	V18	V17	V16	V15 to V9	V8
	Read/Write	R/W							
	After reset	1	1	1	1	1	1	1	1
	Function	Sets size of CS1 area 0: Used for address compare							

Range of possible settings for CS1 area size: 256 bytes to 4 Mbytes.

Memory Address Mask Register (CS2, CS3)

	7	6	5	4	3	2	1	0	
MAMR2 / MAMR3 (00CDH) / (00CFH)	Bit symbol	V22	V21	V20	V19	V18	V17	V16	V15
	Read/Write	R/W							
	After reset	1	1	1	1	1	1	1	1
	Function	Sets size of CS2 or CS3 area 0: Used for address compare							

Range of possible settings for CS2 and CS3 area sizes: 32 Kbytes to 8 Mbytes.

Figure 3.6.3 Memory Address Mask Registers

(3) Setting memory start addresses and address areas

Figure 3.6.4 show an example of specifying a 64-Kbyte address area starting from 010000H using the CS0 areas.

Set 01H in memory start address register MSAR0<S23:16> (Corresponding to the upper 8 bits of the start address). Next, calculate the difference between the start address and the anticipated end address (01FFFFH). Bits 20 to 8 of the result correspond to the mask value to be set for the CS0 area. Setting this value in memory address mask register MAMR0<V20:8> sets the area size. This example sets 07H in MAMR0 to specify a 64-Kbyte area.

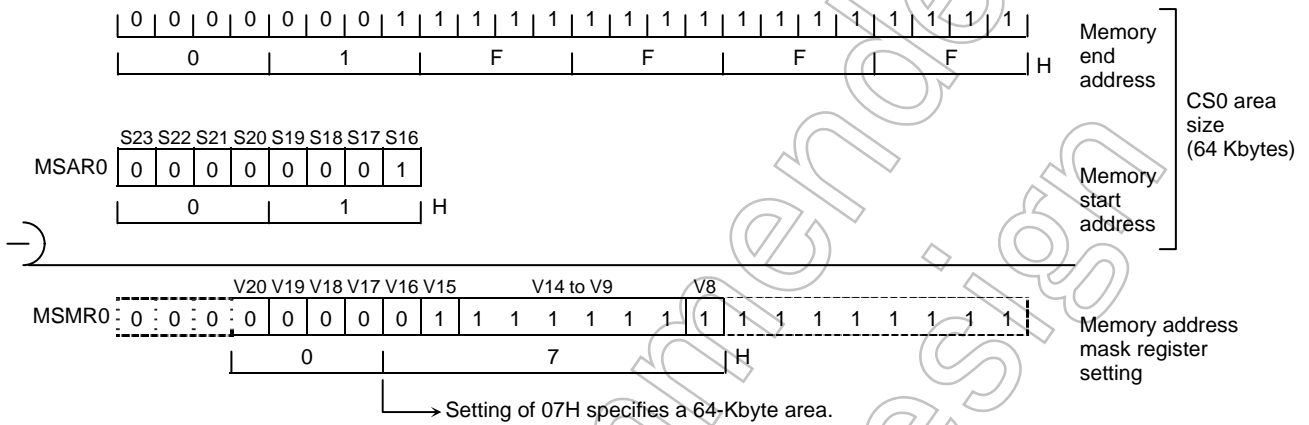

Figure 3.6.4 Example Showing How to Set the CS0 Area

After a reset, MSAR0 to MSAR3 and MAMR0 to MAMR3 are set to FFH. B0CS<B0E>, B1CS<B1E> and B3CS<B3E> are reset to 0. This disabling the CS0, CS1 and CS3 areas. However, as B2CS<B2M> to 0 and B2CS<B2E> to 1, CS2 is enabled from 000FE0H to 000FFFH to 003000H to FFFFFFFH in TMP91FY42. Also, the bus width and number of waits specified in BEXCS are used for accessing addresses outside the specified CS0 to CS3 area. (See 3.6.2 “Chip Select/Wait Control Registers”.)

(4) Address area size specification

Table 3.6.1 shows the relationship between CS area and area size. “Δ” indicates areas that cannot be set by memory start address register and address mask register combinations. When setting an area size using a combination indicated by “Δ”, set the start address mask register in the desired steps starting from 000000H.

If the CS2 area is set to 16-Mbytes or if two or more areas overlap, the smaller CS area number has the higher priority.

Example: To set the area size for CS0 to 128 Kbytes:

a. Valid start addresses

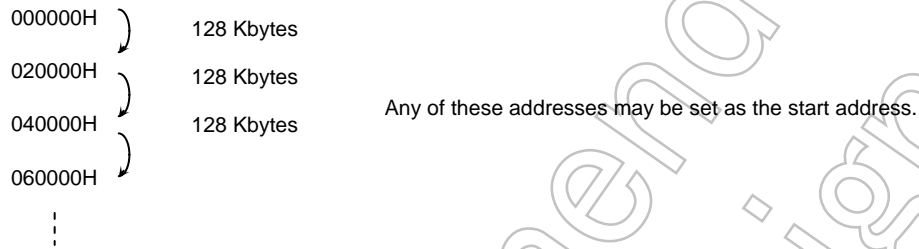

b. Invalid start addresses

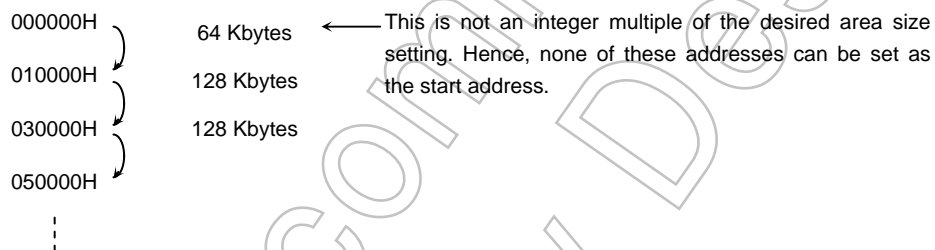

Table 3.6.1 Valid Area Sizes for Each CS Area

Size (Bytes) \ CS Area	256	512	32 K	64 K	128 K	256 K	512 K	1 M	2 M	4 M	8 M
CS0	○	○	○	○	Δ	Δ	Δ	Δ	Δ		
CS1	○	○		○	Δ	Δ	Δ	Δ	Δ	Δ	
CS2			○	○	Δ	Δ	Δ	Δ	Δ	Δ	Δ
CS3			○	○	Δ	Δ	Δ	Δ	Δ	Δ	Δ

Note: “Δ” indicates areas that cannot be set by memory start address register and address mask register combinations.

3.6.2 Chip Select/Wait Control Registers

Figure 3.6.5 lists the chip select/wait control registers.

The master enable/disable, chip select output waveform, data bus width and number of wait states for each address area (CS0 to CS3 and others) are set in their respective chip select/wait control registers, B0CS to B3CS and BEXCS.

Not Recommended
for New Design

	7	6	5	4	3	2	1	0	
B0CS (00C0H)	Bit symbol	B0E		B0OM1	B0OM0	B0BUS	B0W2	B0W1	B0W0
	Read/Write	W		W					
	After reset	0		0	0	0	0	0	0
	Function	0: Disable 1: Enable		Chip select output waveform selection 00: For ROM/SRAM 01: } 10: } Don't care 11: }	Data bus width 0: 16 bits 1: 8 bits	Number of waits 000: 2 waits 100: Reserved 001: 1 wait 101: 3 waits 010: (1 + N) waits 110: 4 waits 011: 0 waits 111: 8 waits			
B1CS (00C1H)	Bit symbol	B1E		B1OM1	B1OM0	B1BUS	B1W2	B1W1	B1W0
	Read/Write	W		W					
	After reset	0		0	0	0	0	0	0
	Function	0: Disable 1: Enable		Chip select output waveform selection 00: For ROM/SRAM 01: } 10: } Don't care 11: }	Data bus width 0: 16 bits 1: 8 bits	Number of waits 000: 2 waits 100: Reserved 001: 1 wait 101: 3 waits 010: (1 + N) waits 110: 4 waits 011: 0 waits 111: 8 waits			
B2CS (00C2H)	Bit symbol	B2E	B2M	B2OM1	B2OM0	B2BUS	B2W2	B2W1	B2W0
	Read/Write	W							
	After reset	1	0	0	0	0	0	0	0
	Functions	0: Disable 1: Enable	CS2 area selection 0: 16-Mbyte area 1: CS area	Chip select output waveform selection 00: For ROM/SRAM 01: } 10: } Don't care 11: }	Data bus width 0: 16 bits 1: 8 bits	Number of waits 000: 2 waits 100: Reserved 001: 1 wait 101: 3 waits 010: (1 + N) waits 110: 4 waits 011: 0 waits 111: 8 waits			
B3CS (00C3H)	Bit symbol	B3E		B3OM1	B3OM0	B3BUS	B3W2	B3W1	B3W0
	Read/Write	W		W					
	After reset	0		0	0	0	0	0	0
	Functions	0: Disable 1: Enable		Chip select output waveform selection 00: For ROM/SRAM 01: } 10: } Don't care 11: }	Data bus width 0: 16 bits 1: 8 bits	Number of waits 000: 2 waits 100: Reserved 001: 1 wait 101: 3 waits 010: (1 + N) waits 110: 4 waits 011: 0 waits 111: 8 waits			
BEXCS (00C7H)	Bit symbol					BEXBUS	BEXW2	BEXW1	BEXW0
	Read/Write					W			
	After reset					0	0	0	0
	Functions					Data bus width 0: 16 bits 1: 8 bits	Number of waits 000: 2 waits 100: Reserved 001: 1 wait 101: 3 waits 010: (1 + N) waits 110: 4 waits 011: 0 waits 111: 8 waits		

Master enable bit

0	Enable
1	Disable

Chip select output waveform selection

00	For ROM/SRAM
01	
10	Don't care
11	

Number of address area waits
(See 3.6.2, (3) Wait control.)

Data bus width selection

0	16-bit data bus
1	8-bit data bus

CS2 area selection

0	16-Mbyte area
1	Specified address area

Figure 3.6.5 Chip Select/Wait Control Registers

(1) Master enable bits

Bit 7 (<B0E>, <B1E>, <B2E> or <B3E>) of a chip select/wait control register is the master bit which is used to enable or disable settings for the corresponding address area. Writing 1 to this bit enables the settings. Reset disables (Sets to 0) <B0E>, <B1E> and <B3E>, and enabled (Sets to 1) <B2E>. This enables area CS2 only.

(2) Data bus width selection

Bit 3 (<B0BUS>, <B1BUS>, <B2BUS>, <B3BUS> or <BEXBUS>) of a chip select/wait control register specifies the width of the data bus. This bit should be set to 0 when memory is to be accessed using a 16-bit data bus and to 1 when an 8-bit data bus is to be used.

This process of changing the data bus width according to the address being accessed is known as dynamic bus sizing. For details of this bus operation see Table 3.6.2.

Table 3.6.2 Dynamic Bus Sizing

Operand Data Bus Width	Operand Start Address	Memory Data Bus Width	CPU Address	CPU Data	
				D15 to D8	D7 to D0
8 bits	2n + 0 (Even number)	8 bits	2n + 0	xxxxx	b7 to b0
		16 bits	2n + 0	xxxxx	b7 to b0
	2n + 1 (Odd number)	8 bits	2n + 1	xxxxx	b7 to b0
		16 bits	2n + 1	b7 to b0	xxxxx
16 bits	2n + 0 (Even number)	8 bits	2n + 0	xxxxx	b7 to b0
			2n + 1	xxxxx	b15 to b8
		16 bits	2n + 0	b15 to b8	b7 to b0
	2n + 1 (Odd number)	8 bits	2n + 1	xxxxx	b7 to b0
			2n + 2	xxxxx	b15 to b8
		16 bits	2n + 1	b7 to b0	xxxxx
32 bits	2n + 0 (Even number)	8 bits	2n + 0	xxxxx	b7 to b0
			2n + 1	xxxxx	b15 to b8
			2n + 2	xxxxx	b23 to b16
			2n + 3	xxxxx	b31 to b24
		16 bits	2n + 0	b15 to b8	b7 to b0
		2n + 2	b31 to b24	b23 to b16	
	2n + 1 (Odd number)	8 bits	2n + 1	xxxxx	b7 to b0
			2n + 2	xxxxx	b15 to b8
			2n + 3	xxxxx	b23 to b16
			2n + 4	xxxxx	b31 to b24
16 bits		2n + 1	b7 to b0	xxxxx	
	2n + 2	b23 to b16	b15 to b8		
	2n + 4	xxxxx	b31 to b24		

Note: xxxxx indicates that the input data from these bits are ignored during a read. During a write, indicates that the bus for these bits goes too high impedance; also, that the write strobe signal for the bus remains inactive.

(3) Wait control

Bits 0 to 2 (<B0W0:2>, <B1W0:2>, <B2W0:2>, <B3W0:2>, <BEXW0:2>) of a chip select/wait control register specify the number of waits that are to be inserted when the corresponding memory area is accessed.

The following types of wait operation can be specified using these bits. Bit settings other than those listed in the table should not be made.

Table 3.6.3 Wait Operation Settings

<BxW2:0>	Number of Waits	Wait Operation
000	2	Inserts a wait of 2 states, irrespective of the $\overline{\text{WAIT}}$ pin state.
001	1	Inserts a wait of 1 state, irrespective of the $\overline{\text{WAIT}}$ pin state.
010	(1 + N)	Samples the state of the $\overline{\text{WAIT}}$ pin after inserting a wait of 1 state. If the $\overline{\text{WAIT}}$ pin is low, the waits continue and the bus cycle is extended until the pin goes high.
011	0	Ends the bus cycle without a wait, regardless of the $\overline{\text{WAIT}}$ pin state.
100	Reserved	Invalid setting
101	3	Inserts a wait of 3 states, irrespective of the $\overline{\text{WAIT}}$ pin state.
110	4	Inserts a wait of 4 states, irrespective of the $\overline{\text{WAIT}}$ pin state.
111	8	Inserts a wait of 8 states, irrespective of the $\overline{\text{WAIT}}$ pin state.

A reset sets these bits to 000 (2 waits).

(4) Bus width and wait control for an area other than CS0 to CS3

The chip select/wait control register BEXCS controls the bus width and number of waits when memory locations which are not in one of the four user-specified address areas (CS0 to CS3) are accessed. The BEXCS register settings are always enabled for areas other than CS0 to CS3.

(5) Selecting 16-Mbyte area/specified address area

Setting B2CS<B2M> (Bit 6 of the chip select/wait control register for CS2) to 0 designates the 16-Mbyte area (005000H~FBFFFFH) as the CS2 area. Setting B2CS<B2M> to 1 designates the address area specified by the start address register MSAR2 and the address mask register MAMR2 as CS2 (e.g., if B2CS<B2M> = 1, CS2 is specified in the same manner as CS0, CS1 and CS3 are).

A reset clears this bit to 0, specifying CS2 as a 16-Mbyte address area.

(6) Procedure for setting chip select/wait control

When using the chip select/wait control function, set the registers in the following order:

1. Set the memory start address registers MSAR0 to MSAR3.
Set the start addresses for CS0 to CS3.
2. Set the memory address mask registers MAMR0 to MAMR3.
Set the sizes of CS0 to CS3.
3. Set the chip select/wait control registers B0CS to B3CS.

Set the chip select output waveform, data bus width, number of waits and master enable/disable status for $\overline{CS0}$ to $\overline{CS3}$.

The CS0 to CS3 pins can also function as pins P40 to P43. To output a chip select signal using one of these pins, set the corresponding bit in the port 4 function register P6FC to 1.

If a CS0 to CS3 address is specified which is actually an internal I/O and RAM area address, the CPU accesses the internal address area and no chip select signal is output on any of the $\overline{CS0}$ to $\overline{CS3}$ pins.

Setting example:

In this example CS0 is set to be the 64-Kbyte area 010000H to 01FFFFH. The bus width is set to 16 bits and the number of waits is set to 0.

MSAR0 = 01H	Start address: 010000H
MAMR0 = 07H	Address area: 64 Kbytes
B0CS = 83H	ROM/SRAM, 16-bit data bus, 0 waits, CS0 area settings enabled.

3.6.3 Connecting External Memory

Figure 3.6.6 shows an example of how to connect external memory to the TMP91FY42.

In this example the ROM is connected using a 16-bit bus. The RAM and I/O are connected using an 8-bit bus.

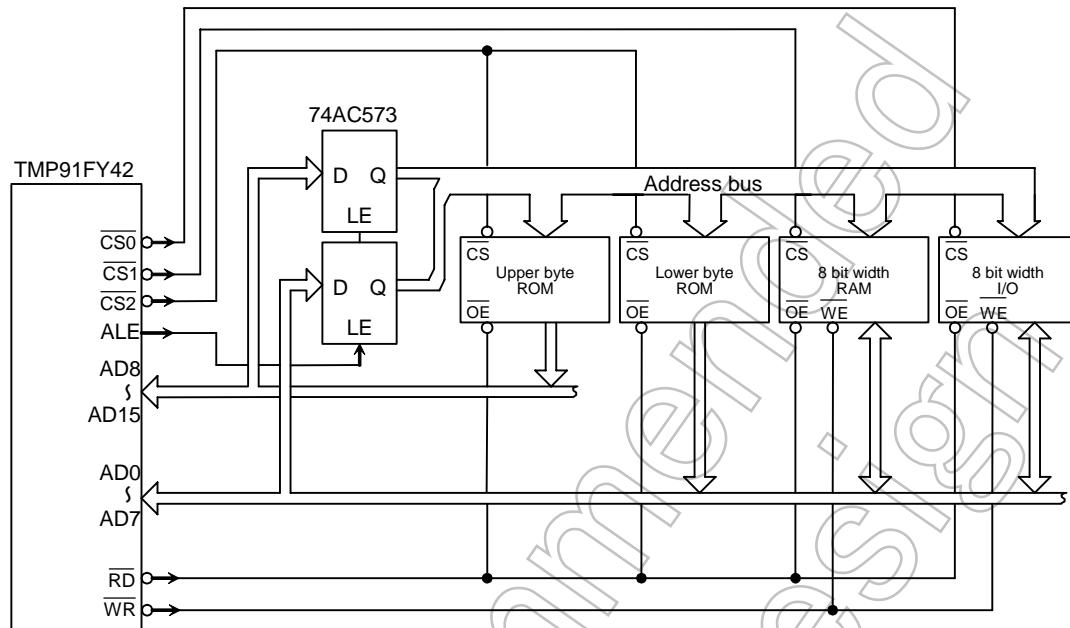

Figure 3.6.6 Example of External Memory Connection
(ROM uses 16-bit bus; RAM and I/O use 8-bit bus.)

A reset clears all bits of the port 4 control register P4CR and the port 4 function register P4FC to 0 and disables output of the CS signal. To output the CS signal, the appropriate bit must be set to 1.

3.7 8-Bit Timers (TMRA)

The TMP91FY42 features 8 channel (TMRA0 to TMRA7) built-in 8-bit timers.

These timers are paired into 4 modules: TMRA01, TMRA23, TMRA45 and TMRA67. Each module consists of 8 channels and can operate in any of the following 4 operating modes.

- 8-bit interval timer mode
- 16-bit interval timer mode
- 8-bit programmable square wave pulse generation output mode (PPG: Variable duty cycle with variable period)
- 8-bit pulse width modulation output mode (PWM: Variable duty cycle with constant period)

Figure 3.7.1 to Figure 3.7.3 show block diagrams for TMRA01, TMRA23, TMRA45 and TMRA67.

Each channel consists of an 8-bit up counter, an 8-bit comparator and an 8-bit timer register. In addition, a timer flip-flop and a prescaler are provided for each pair of channels.

The operation mode and timer flip-flop condition are controlled by 5-byte registers.

We call control registers SFRs: Special function registers.

Each of the four modules (TMRA01, TMRA23, TMRA45 and TMRA67) can be operated independently. All modules operate in the same manner; hence only the operation of TMRA01 is explained here.

The contents of this chapter are as follows.

3.7.1 Block Diagrams

3.7.2 Operation of Each Circuit

3.7.3 SFRs

3.7.4 Operation in Each Mode

- (1) 8-bit timer mode
- (2) 16-bit timer mode
- (3) 8-bit PPG (Programmable pulse generation) output mode
- (4) 8-bit PWM (Pulse width modulation) output mode
- (5) Settings for each mode

Table 3.7.1 Registers and Pins for Each Module

Module		TMRA01	TMRA23	TMRA45	TMRA67
External pin	Input pin for external clock	TA0IN (shared with P70)	None	TA4IN (shared with P73)	None
	Output pin for timer flip-flop	TA1OUT (shared with P71)	TA3OUT (shared with P72)	TA5OUT (shared with P74)	TA7OUT (shared with P75)
SFR (Address)	Timer run register	TA01RUN (0100H)	TA23RUN (0108H)	TA45RUN (0110H)	TA67RUN (0118H)
	Timer register	TA0REG (0102H) TA1REG (0103H)	TA2REG (010AH) TA3REG (010BH)	TA4REG (0112H) TA5REG (0113H)	TA6REG (011AH) TA7REG (011BH)
	Timer mode register	TA01MOD (0104H)	TA23MOD (010CH)	TA45MOD (0114H)	TA67MOD (011CH)
	Timer flip-flop control register	TA1FFCR (0105H)	TA3FFCR (010DH)	TA5FFCR (0115H)	TA7FFCR (011DH)

3.7.1 Block Diagrams

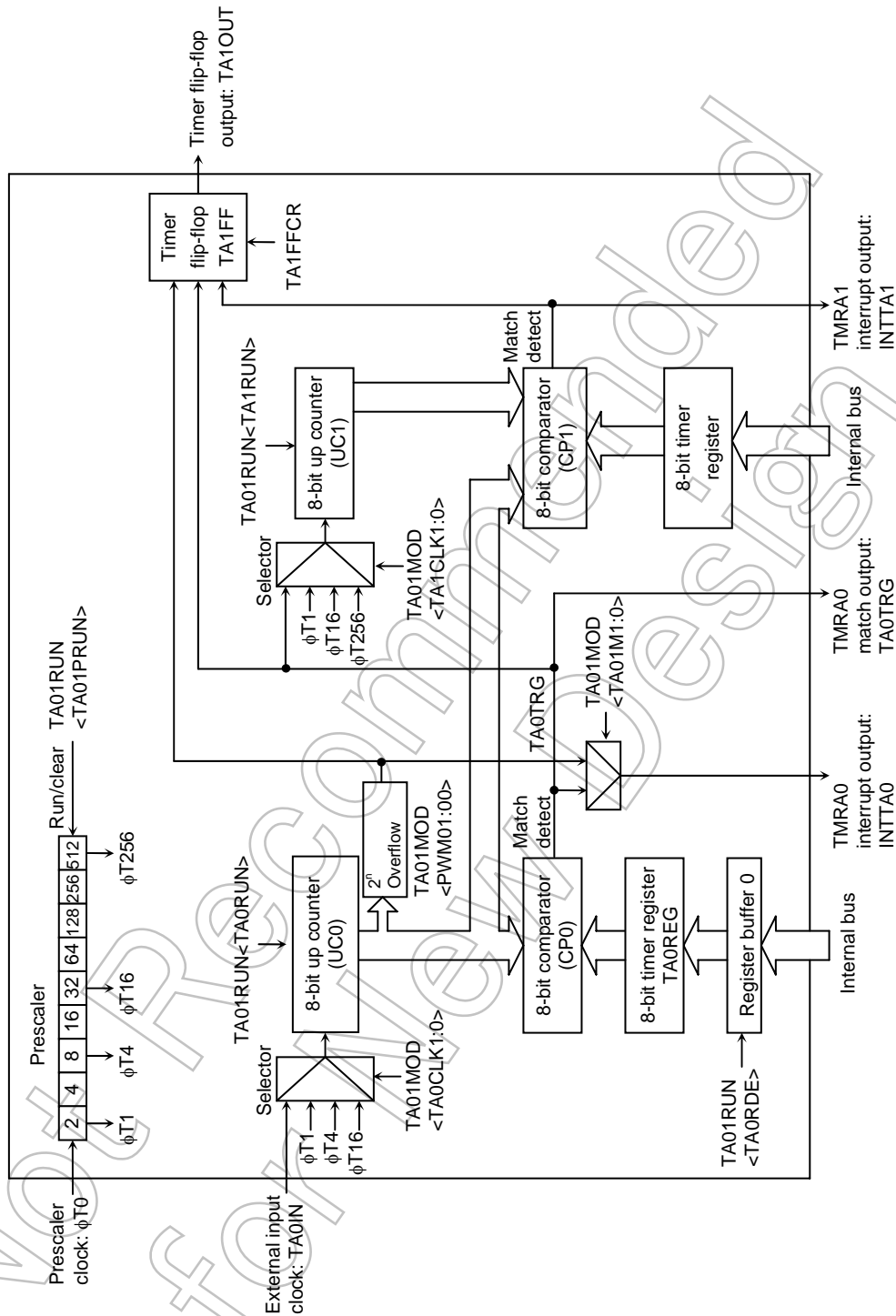

Figure 3.7.1 TMRA01 Block Diagram

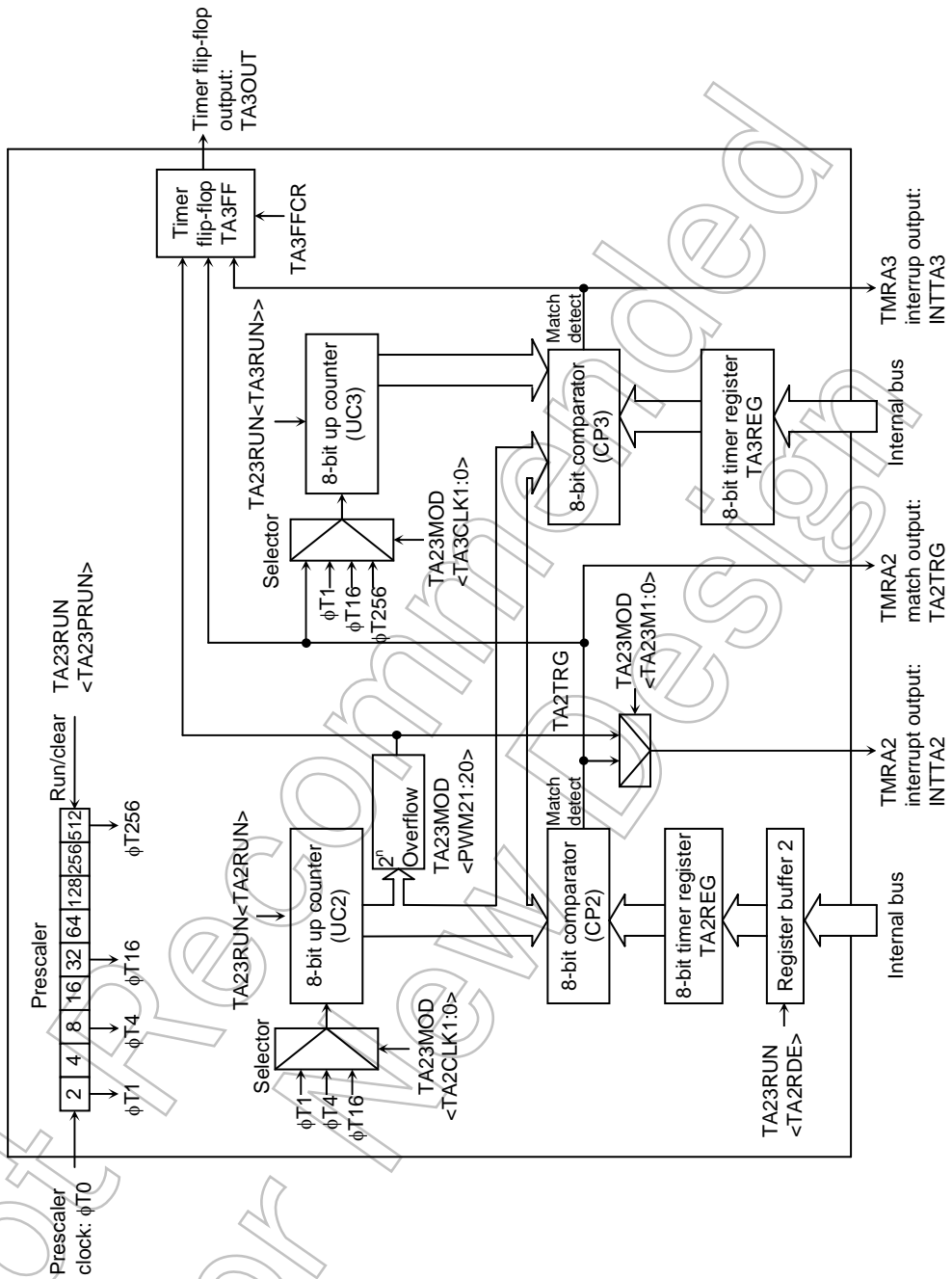

Figure 3.7.2 TMRA23 Block Diagram

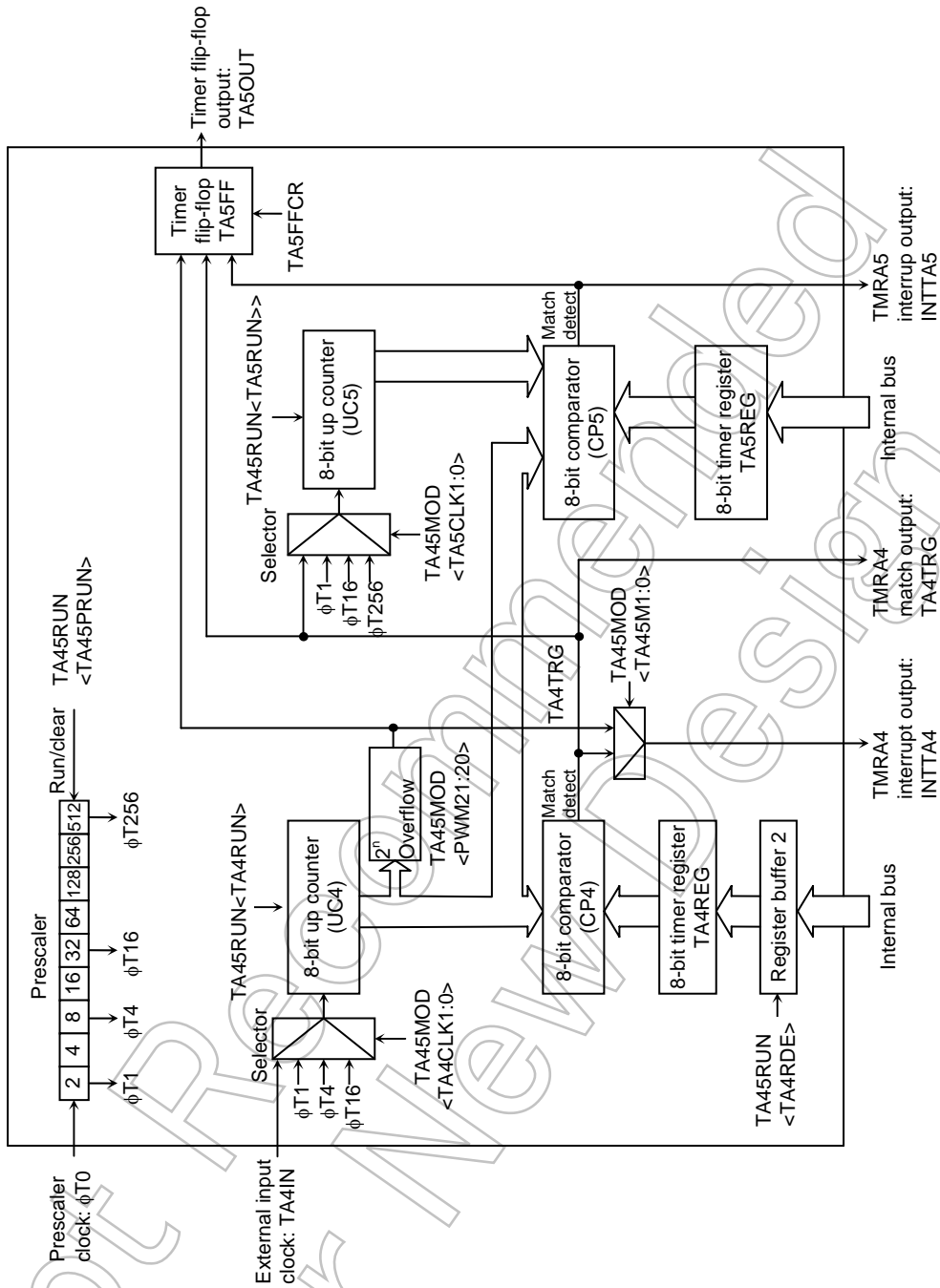

Figure 3.7.3 TMRA45 Block Diagram

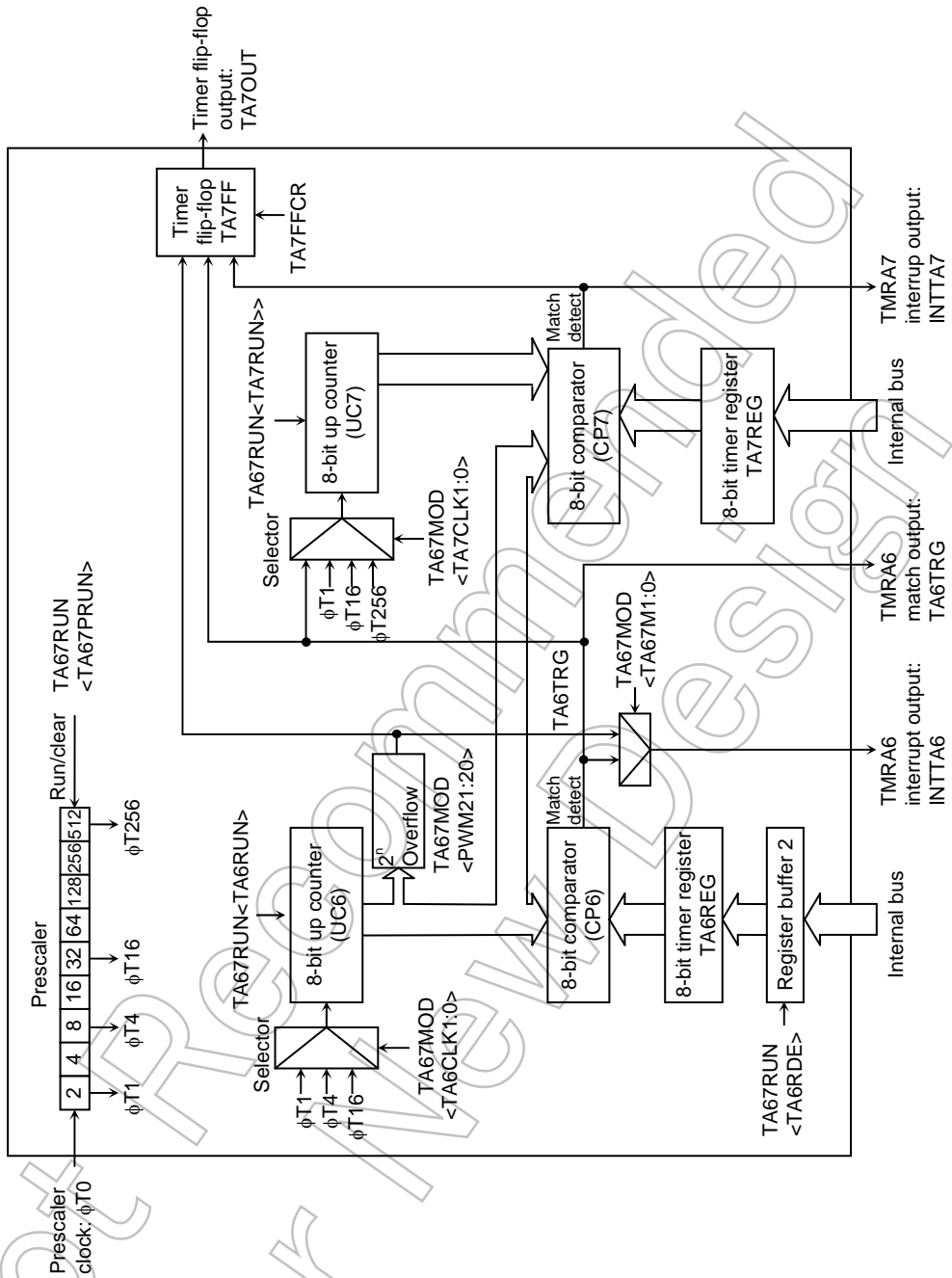

Figure 3.7.4 TMRA67 Block Diagram

3.7.2 Operation of Each Circuit

(1) Prescalers

A 9-bit prescaler generates the input clock to TMRA01.

The $\phi T0$ as the input clock to prescaler is a clock divided by 4 which selected using the prescaler clock selection register SYSCR0<PRCK1:0>.

The prescaler's operation can be controlled using TA01RUN<TA01PRUN> in the timer control register. Setting <TA01PRUN> to 1 starts the count; setting <TA01PRUN> to 0 clears the prescaler to 0 and stops operation. Table 3.7.2 shows the various prescaler output clock resolutions.

Table 3.7.2 Prescaler Output Clock Resolution

at $f_c = 27\text{MHz}$, $f_s = 32.768\text{ kHz}$

System Clock Selection SYSCR1 <SYSCK>	Prescaler Clock Selection SYSCR0 <PRCK1:0>	Gear Value SYSCR1 <GEAR2:0>	Prescaler Output Clock Resolution			
			$\phi T1$	$\phi T4$	$\phi T16$	$\phi T256$
1 (fs)		XXX	$2^3/f_s$ (244 μs)	$2^5/f_s$ (977 μs)	$2^7/f_s$ (3.9 ms)	$2^{11}/f_s$ (62.5 ms)
0 (fc)	00 (f _{FPH})	000 (fc)	$2^3/f_c$ (0.3 μs)	$2^5/f_c$ (1.2 μs)	$2^7/f_c$ (4.7 μs)	$2^{11}/f_c$ (75.9 μs)
		001 (fc/2)	$2^4/f_c$ (0.6 μs)	$2^6/f_c$ (2.4 μs)	$2^8/f_c$ (9.5 μs)	$2^{12}/f_c$ (151.7 μs)
		010 (fc/4)	$2^5/f_c$ (1.2 μs)	$2^7/f_c$ (4.7 μs)	$2^9/f_c$ (19.0 μs)	$2^{13}/f_c$ (303.4 μs)
		011 (fc/8)	$2^6/f_c$ (2.4 μs)	$2^8/f_c$ (9.5 μs)	$2^{10}/f_c$ (37.9 μs)	$2^{14}/f_c$ (606.8 μs)
		100 (fc/16)	$2^7/f_c$ (4.7 μs)	$2^9/f_c$ (19.0 μs)	$2^{11}/f_c$ (75.9 μs)	$2^{15}/f_c$ (1213.6 μs)
	10 (fc/16 clock)	XXX	$2^7/f_c$ (4.7 μs)	$2^9/f_c$ (19.0 μs)	$2^{11}/f_c$ (75.9 μs)	$2^{15}/f_c$ (1213.6 μs)

xxx: Don't care

(2) Up counters (UC0 and UC1)

These are 8-bit binary counters which count up the input clock pulses for the clock specified by TA01MOD.

The input clock for UC0 is selectable and can be either the external clock input via the TA0IN pin or one of the three internal clocks $\phi T1$, $\phi T4$ or $\phi T16$. The clock setting is specified by the value set in TA01MOD<TA0CLK1:0>.

The input clock for UC1 depends on the operation mode. In 16-bit timer mode, the overflow output from UC0 is used as the input clock. In any mode other than 16-bit timer mode, the input clock is selectable and can either be one of the internal clocks $\phi T1$, $\phi T16$ or $\phi T256$, or the comparator output (The match detection signal) from TMRA0.

For each interval timer the timer operation control register bits TA01RUN<TA0RUN> and TA01RUN<TA1RUN> can be used to stop and clear the up counters and to control their count. A reset clears both up counters, stopping the timers.

(3) Timer registers (TA0REG and TA1REG)

These are 8-bit registers which can be used to set a time interval. When the value set in the timer register TA0REG or TA1REG matches the value in the corresponding up counter, the comparator match detect signal goes active. If the value set in the timer register is 00H, the signal goes active when the up counter overflows.

The TA0REG are double buffer structure, each of which makes a pair with register buffer.

The setting of the bit TA01RUN<TA0RDE> determines whether TA0REG's double buffer structure is enabled or disabled. It is disabled if <TA0RDE> = 0 and enabled if <TA0RDE> = 1.

When the double buffer is enabled, data is transferred from the register buffer to the timer register when a 2ⁿ overflow occurs in PWM mode, or at the start of the PPG cycle in PPG mode. Hence the double buffer cannot be used in timer mode.

A reset initializes <TA0RDE> to 0, disabling the double buffer. To use the double buffer, write data to the timer register, set <TA0RDE> to 1, and write the following data to the register buffer. Figure 3.7.5 show the configuration of TA0REG.

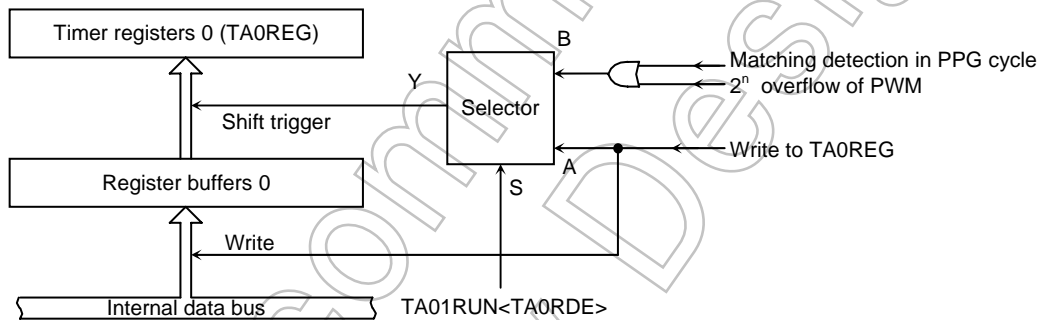

Figure 3.7.5 Configuration of TA0REG

Note: The same memory address is allocated to the timer register and the register buffer. When <TA0RDE> = 0, the same value is written to the register buffer and the timer register; when <TA0RDE> = 1, only the register buffer is written to.

The address of each timer register is as follows.

TA0REG: 000102H	TA1REG: 000103H
TA2REG: 00010AH	TA3REG: 00010BH
TA4REG: 000112H	TA5REG: 000113H
TA6REG: 00011AH	TA7REG: 00011BH

All these registers are write only and cannot be read.

(4) Comparator (CP0)

The comparator compares the value in an up counter with the value set in a timer register. If they match, the up counter is cleared to zero and an interrupt signal (INTTA0 or INTTA1) is generated. If timer flip-flop inversion is enabled, the timer flip-flop is inverted at the same time.

(5) Timer flip-flop (TA1FF)

The timer flip-flop (TA1FF) is a flip-flop inverted by the match detects signal (8-bit comparator output) of each interval timer.

Whether inversion is enabled or disabled is determined by the setting of the bit TA1FFCR<TA1FFIE> in the timer flip-flop control register.

A reset clears the value of TA1FF1 to 0.

Writing 01 or 10 to TA1FFCR<TA1FFC1:0> sets TA1FF to 0 or 1. Writing 00 to these bits inverts the value of TA1FF. (This is known as software inversion.)

The TA1FF signal is output via the TA1OUT pin (Concurrent with P71). When this pin is used as the timer output, the timer flip-flop should be set beforehand using the port 7 function register P7CR, P7FC.

Not Recommended for New Designs

3.7.3 SFRs

TMRA01 Run Register

		7	6	5	4	3	2	1	0
TA01RUN (0100H)	Bit symbol	TA0RDE				I2TA01	TA01PRUN	TA1RUN	TA0RUN
	Read/Write	R/W				R/W			
	After reset	0				0	0	0	0
	Function	Double buffer 0: Disable 1: Enable				IDLE2 0: Stop 1: Operate	TMRA01 prescaler	Up counter (UC1)	Up counter (UC0)
							0: Stop and clear 1: Run (Count up)		

0	Disable
1	Enable

0	Stop and clear
1	Run (Count up)

Note: The values of bits 4, 5, 6 of TA01RUN are undefined when read.

TMRA23 Run Register

		7	6	5	4	3	2	1	0
TA23RUN (0108H)	Bit symbol	TA2RDE				I2TA23	TA23PRUN	TA3RUN	TA2RUN
	Read/Write	R/W				R/W			
	After reset	0				0	0	0	0
	Function	Double buffer 0: Disable 1: Enable				IDLE2 0: Stop 1: Operate	TMRA23 prescaler	Up counter (UC3)	Up counter (UC2)
							0: Stop and clear 1: Run (Count up)		

0	Disable
1	Enable

0	Stop and clear
1	Run (Count up)

Note: The values of bits 4, 5, 6 of TA23RUN are undefined when read.

Figure 3.7.6 TMRA Registers

TMRA45 Run Register

	7	6	5	4	3	2	1	0
TA45RUN (0110H)	Bit symbol	TA5RDE			I2TA45	TA45PRUN	TA5RUN	TA5RUN
	Read/Write	R/W				R/W		
	After reset	0			0	0	0	0
	Function	Double buffer 0: Disable 1: Enable			IDLE2 0: Stop 1: Operate	TMRA45 prescaler	Up counter (UC5)	Up counter (UC4)
						0: Stop and clear 1: Run (Count up)		

TA4REG double buffer control	
0	Disable
1	Enable

Timer run/stop control	
0	Stop and clear
1	Run (Count up)

Note: The values of bits 4, 5, 6 of TA45RUN are undefined when read.

TMRA23 Run Register

	7	6	5	4	3	2	1	0
TA67RUN (0118H)	Bit symbol	TA6RDE			I2TA67	TA67PRUN	TA7RUN	TA6RUN
	Read/Write	R/W				R/W		
	After reset	0			0	0	0	0
	Function	Double buffer 0: Disable 1: Enable			IDLE2 0: Stop 1: Operate	TMRA67 prescaler	Up counter (UC7)	Up counter (UC6)
						0: Stop and clear 1: Run (Count up)		

TA6REG double buffer control	
0	Disable
1	Enable

Timer run/stop control	
0	Stop and clear
1	Run (Count up)

Note: The values of bits 4, 5, 6 of TA67RUN are undefined when read.

Figure 3.7.7 TMRA Registers

TMRA01 Mode Register

	7	6	5	4	3	2	1	0
Bit symbol	TA01M1	TA01M0	PWM01	PWM00	TA1CLK1	TA1CLK0	TA0CLK1	TA0CLK0
Read/Write	R/W							
After reset	0	0	0	0	0	0	0	0
Function	Operation mode 00: 8-bit timer mode 01: 16-bit timer mode 10: 8-bit PPG mode 11: 8-bit PWM mode		PWM cycle 00: Reserved 01: 2 ⁶ 10: 2 ⁷ 11: 2 ⁸		Source clock for TMRA1 00: TA0TRG 01: φT1 10: φT16 11: φT256		Source clock for TMRA0 00: TA0IN pin 01: φT1 10: φT4 11: φT16	

TMRA0 source clock selection

<TA0CLK1:0>	00	TA0IN input
	01	φT1
	10	φT4
	11	φT16

TMRA1 source clock selection

		TA01MOD <TA01M1:0> ≠ 01	TA01MOD <TA01M1:0> = 01
<TA1CLK1:0>	00	Comparator output from TMRA0	Overflow output from TMRA0 (16-bit timer mode)
	01	φT1	
	10	φT16	
	11	φT256	

PWM cycle selection

<PWM01:00>	00	Reserved
	01	2 ⁶ × source clock
	10	2 ⁷ × source clock
	11	2 ⁸ × source clock

TMRA0 source clock selection

<TA01MA1:0>	00	8-bit timers 2ch
	01	16-bit timer
	10	8-bit PPG
	11	8-bit PWM (TMRA0), 8-bit timer (TMRA1)

Figure 3.7.8 TMRA Registers

TMRA23 Mode Register

TA23MOD
(010CH)

	7	6	5	4	3	2	1	0
Bit symbol	TA23M1	TA23M0	PWM21	PWM20	TA3CLK1	TA3CLK0	TA2CLK1	TA2CLK0
Read/Write	R/W							
After reset	0	0	0	0	0	0	0	0
Function	Operation mode 00: 8-bit timer mode 01: 16-bit timer mode 10: 8-bit PPG mode 11: 8-bit PWM mode		PWM cycle 00: Reserved 01: 2 ⁶ 10: 2 ⁷ 11: 2 ⁸		TMRA3 clock for TMRA3 00: TA2TRG 01: φT1 10: φT16 11: φT256		TMRA2 clock for TMRA2 00: Reserved 01: φT1 10: φT4 11: φT16	

TMRA2 source clock selection

<TA2CLK1:0>	00	Don't set
	01	φT1
	10	φT4
	11	φT16

TMRA3 source clock selection

		TA23MOD <TA23M1:0> ≠ 01	TA23MOD <TA23M1:0> = 01
<TA3CLK1:0>	00	Comparator output from TMRA2	Overflow output from TMRA2 (16-bit timer mode)
	01	φT1	
	10	φT16	
	11	φT256	

PWM cycle selection

<PWM21:20>	00	Reserved
	01	2 ⁶ × source clock
	10	2 ⁷ × source clock
	11	2 ⁸ × source clock

TMRA2 source clock selection

<TA23MA1:0>	00	8-bit timers 2ch
	01	16-bit timer
	10	8-bit PPG
	11	8-bit PWM (TMRA2), 8-bit timer (TMRA3)

Figure 3.7.9 TMRA Registers

TMRA45 Mode Register

	7	6	5	4	3	2	1	0
Bit symbol	TA45M1	TA45M0	PWM41	PWM40	TA5CLK1	TA5CLK0	TA4CLK1	TA4CLK0
Read/Write	R/W							
After reset	0	0	0	0	0	0	0	0
Function	Operation mode 00: 8-bit timer mode 01: 16-bit timer mode 10: 8-bit PPG mode 11: 8-bit PWM mode		PWM cycle 00: Reserved 01: 2 ⁶ 10: 2 ⁷ 11: 2 ⁸		Source clock for TMRA5 00: TA4TRG 01: φT1 10: φT16 11: φT256		Source clock for TMRA4 00: TA4IN pin 01: φT1 10: φT4 11: φT16	

TMRA4 source clock selection

<TA4CLK1:0>	00	TA4IN input
	01	φT1
	10	φT4
	11	φT16

TMRA5 source clock selection

		TA45MOD <TA45M1:0> ≠ 01	TA45MOD <TA45M1:0> = 01
<TA5CLK1:0>	00	Comparator output from TMRA4	Overflow output from TMRA4 (16-bit timer mode)
	01	φT1	
	10	φT16	
	11	φT256	

PWM cycle selection

<PWM45:00>	00	Reserved
	01	2 ⁶ × source clock
	10	2 ⁷ × source clock
	11	2 ⁸ × source clock

TMRA45 source clock selection

<TA45MA1:0>	00	8-bit timers 2ch
	01	16-bit timer
	10	8-bit PPG
	11	8-bit PWM (TMRA4), 8-bit timer (TMRA5)

Figure 3.7.10 TMRA Registers

TMRA67 Mode Register

	7	6	5	4	3	2	1	0
Bit symbol	TA67M1	TA67M0	PWM61	PWM60	TA7CLK1	TA7CLK0	TA6CLK1	TA6CLK0
Read/Write	R/W							
After reset	0	0	0	0	0	0	0	0
Function	Operation mode 00: 8-bit timer mode 01: 16-bit timer mode 10: 8-bit PPG mode 11: 8-bit PWM mode		PWM cycle 00: Reserved 01: 2 ⁶ 10: 2 ⁷ 11: 2 ⁸		TMRA7 clock for TMRA7 00: TA6TRG 01: φT1 10: φT16 11: φT256		TMRA6 clock for TMRA6 00: Reserved 01: φT1 10: φT4 11: φT16	

TMRA6 source clock selection

<TA6CLK1:0>	00	Don't set
	01	φT1
	10	φT4
	11	φT16

TMRA7 source clock selection

		TA67MOD <TA67M1:0> ≠ 01	TA67MOD <TA67M1:0> = 01
<TA7CLK1:0>	00	Comparator output from TMRA6	Overflow output from TMRA6 (16-bit timer mode)
	01	φT1	
	10	φT16	
	11	φT256	

PWM cycle selection

<PWM61:60>	00	Reserved
	01	2 ⁶ × source clock
	10	2 ⁷ × source clock
	11	2 ⁸ × source clock

TMRA67 source clock selection

<TA67MA1:0>	00	8-bit timers 2ch
	01	16-bit timer
	10	8-bit PPG
	11	8-bit PWM (TMRA6), 8-bit timer (TMRA7)

Figure 3.7.11 TMRA Registers

TMRA1 Flip-Flop Control Register

		7	6	5	4	3	2	1	0
TA1FFCR (0105H)	Bit symbol					TA1FFC1	TA1FFC0	TA1FFIE	TA1FFIS
	Read/Write					R/W		R/W	
	After reset					1	1	0	0
	Function					00: Invert TA1FF 01: Set TA1FF 10: Clear TA1FF 11: Don't care		TA1FF control for inversion 0: Disable 1: Enable	TA1FF inversion select 0: TMRA0 1: TMRA1

Read-modify-write instructions are prohibited.

Inverse signal for timer flip-flop 1 (TA1FF) (Don't care except in 8-bit timer mode)

TA1FFIS	0	Inversion by TMRA0
	1	Inversion by TMRA1

Inversion of TA1FF

TA1FFIE	0	Disabled
	1	Enabled

Control of TA1FF

<TA1FFC1:0>	00	Inverts the value of TA1FF
	01	Sets TA1FF to 1
	10	Clears TA1FF to 0
	11	Don't care

Note: The values of bits 4, 5, 6 of TA1FFCR are undefined when read.

Figure 3.7.12 TMRA Registers

TMRA3 Flip-Flop Control Register

TA3FFCR
(010DH)

Read-
modify-write
instructions
are
prohibited.

	7	6	5	4	3	2	1	0
Bit symbol					TA3FFC1	TA3FFC0	TA3FFIE	TA3FFIS
Read/Write					R/W		R/W	
After reset					1	1	0	0
Function					00: Invert TA3FF 01: Set TA3FF 10: Clear TA3FF 11: Don't care		TA3FF control for inversion 0: Disable 1: Enable	TA3FF inversion select 0: TMRA2 1: TMRA3

Inverse signal for timer flip-flop 3 (TA3FF) (Don't care except in 8-bit timer mode)

TA3FFIS	0	Inversion by TMRA2
	1	Inversion by TMRA3

Inversion of TA3FF

TA3FFIE	0	Disabled
	1	Enabled

Control of TA3FF

<TA3FFC1:0>	00	Inverts the value of TA3FF
	01	Sets TA3FF to 1
	10	Clears TA3FF to 0
	11	Don't care

Note: The values of bits 4, 5, 6 of TA3FFCR are undefined when read.

Figure 3.7.13 TMRA Registers

TMRA5 Flip-Flop Control Register

	7	6	5	4	3	2	1	0
TA5FFCR (0115H)	/				TA5FFC1	TA3FFC0	TA5FFIE	TA5FFIS
Read/Write	/				R/W		R/W	
After reset	/				1	1	0	0
Function	/				00: Invert TA5FF 01: Set TA5FF 10: Clear TA5FF 11: Don't care		TA5FF control for inversion 0: Disable 1: Enable	TA5FF inversion select 0: TMRA4 1: TMRA5

Read-modify-write instructions are prohibited.

Inverse signal for timer flip-flop 5 (TA5FF) (Don't care except in 8-bit timer mode)

TA5FFIS	0	Inversion by TMRA4
	1	Inversion by TMRA5

Inversion of TA5FF

TA5FFIE	0	Disabled
	1	Enabled

Control of TA5FF

<TA5FFC1:0>	00	Inverts the value of TA5FF
	01	Sets TA5FF to 1
	10	Clears TA5FF to 0
	11	Don't care

Note: The values of bits 4, 5, 6 of TA5FFCR are undefined when read.

Figure 3.7.14 TMRA Registers

Not Recommended for New Design

TMRA7 Flip-Flop Control Register

	7	6	5	4	3	2	1	0
TA7FFCR (011DH)					TA7FFC1	TA7FFC0	TA7FFIE	TA7FFIS
Read/Write					R/W		R/W	
After reset					1	1	0	0
Function					00: Invert T75FF 01: Set TA7FF 10: Clear TA7FF 11: Don't care		TA7FF control for inversion 0: Disable 1: Enable	TA7FF inversion select 0: TMRA6 1: TMRA7

Read-modify-write instructions are prohibited.

Inverse signal for timer flip-flop 7 (TA7FF) (Don't care except in 8-bit timer mode)

TA5FFIS	0	Inversion by TMRA6
	1	Inversion by TMRA7

Inversion of TA7FF

TA7FFIE	0	Disabled
	1	Enabled

Control of TA7FF

<TA7FFC1:0>	00	Inverts the value of TA7FF
	01	Sets TA7FF to 1
	10	Clears TA7FF to 0
	11	Don't care

Note: The values of bits 4, 5, 6 of TA7FFCR are undefined when read.

Figure 3.7.15 TMRA Registers

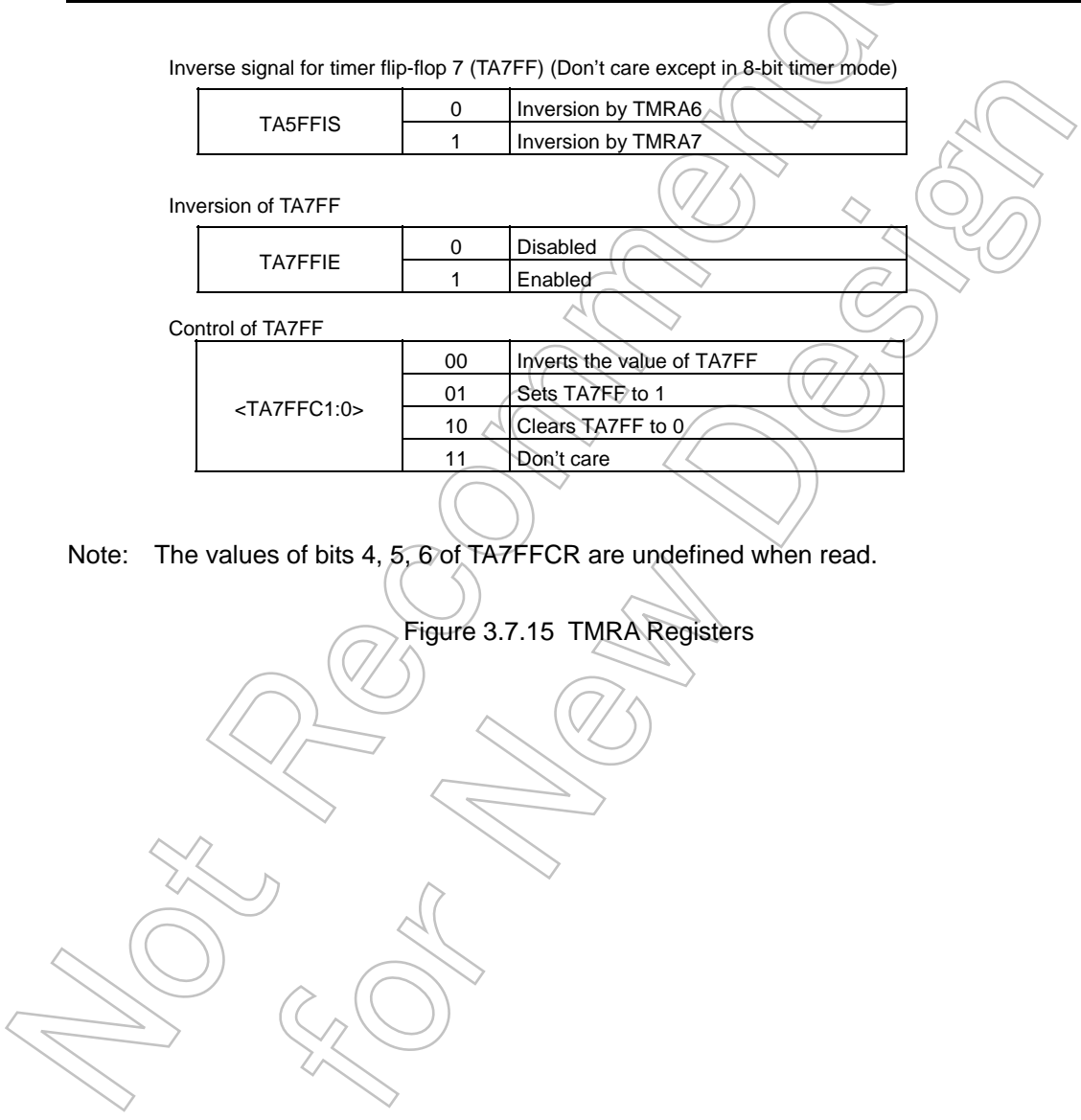

TMRA register

	7	6	5	4	3	2	1	0	
TA0REG (0102H)	bit Symbol	-							
	Read/Write	W							
	After reset	Undefined							
TA1REG (0103H)	bit Symbol	-							
	Read/Write	W							
	After reset	Undefined							
TA2REG (010AH)	bit Symbol	-							
	Read/Write	W							
	After reset	Undefined							
TA3REG (010BH)	bit Symbol	-							
	Read/Write	W							
	After reset	Undefined							
TA4REG (0112H)	bit Symbol	-							
	Read/Write	W							
	After reset	Undefined							
TA5REG (0113H)	bit Symbol	-							
	Read/Write	W							
	After reset	Undefined							
TA6REG (011AH)	bit Symbol	-							
	Read/Write	W							
	After reset	Undefined							
TA7REG (011BH)	bit Symbol	-							
	Read/Write	W							
	After reset	Undefined							

Note: The above registers are prohibited read-modify-write instruction.

Figure 3.7.16 TMRA Registers

3.7.4 Operation in Each Mode

(1) 8-bit timer mode

Both TMRA0 and TMRA1 can be used independently as 8-bit interval timers.

Setting its function or counter data for TMRA0 and TMRA1 after stop these registers.

a. Generating interrupts at a fixed interval (using TMRA1)

To generate interrupts at constant intervals using TMRA1 (INTTA1), first stop TMRA1 then set the operation mode, input clock and a cycle to TA01MOD and TA1REG register, respectively. Then, enable the interrupt INTTA1 and start TMRA1 counting.

Example: To generate an INTTA1 interrupt every 12 μseconds at $f_c = 27$ MHz, set each register as follows:

		* Clock state								System clock: High frequency (f_c)	
										Prescaler clock: f_{PPH}	
		MSB				LSB					
		7	6	5	4	3	2	1	0		
[TA01RUN	←	-	X	X	X	-	-	0	-	Stop TMRA1 and clear it to 0.
	TA01MOD	←	0	0	X	X	1	0	X	X	Select 8-bit timer mode and select $\phi T1$ ($2^3/f_c$) s at $f_c = 27$ MHz) as the input clock.
	TA1REG	←	0	0	1	0	1	0	0	0	Set TA1REG to $12 \mu s \div \phi T1$ ($2^3/f_c$) s $\approx 40 = 28H$.
	INTETA01	←	-	1	0	1	-	-	-	-	Enable INTTA1 and set it to level 5.
	TA01RUN	←	-	X	X	X	-	1	1	-	Start TMRA1 counting.

X: Don't care, -: No change

Select the input clock using in Table 3.7.2.

Note: The input clocks for TMRA0 and TMRA1 are different from as follows.

TMRA0: TA0IN input, $\phi T1$, $\phi T4$ or $\phi T16$

TMRA1: Match output of TMRA0, $\phi T1$, $\phi T16$, $\phi T256$

Not for New

b. Generating a 50% duty ratio square wave pulse

The state of the timer flip-flop (TA1FF) is inverted at constant intervals and its status output via the timer output pin (TA1OUT).

Example: To output a 1.8 μ s square wave pulse from the TA1OUT pin at $f_c = 27$ MHz, use the following procedure to make the appropriate register settings. This example uses TMRA1; however, either TMRA0 or TMRA1 may be used.

* Clock state

System clock: High frequency (f_c)
 Clock gear: 1 (f_c)
 Prescaler clock: f_{PPH}

	7	6	5	4	3	2	1	0
TA01RUN	← -	X	X	X	-	-	0	-
TA01MOD	← 0	0	X	X	0	1	X	X
TA1REG	← 0	0	0	0	0	0	1	1
TA1FFCR	← X	X	X	X	1	0	1	1
PBCR	← X	-	-	-	-	-	1	-
PBFC	← X	-	-	-	-	-	1	X
TA01RUN	← -	X	X	X	-	1	1	-

- Stop TMRA1 and clear it to 0.
- Select 8-bit timer mode and select $\phi T1$ ($(2^3/f_c)$ s at $f_c = 27$ MHz) as the input clock.
- Set the timer register to $1.8 \mu\text{s} \div \phi T1 (2^3/f_c) \text{ s} \div 2 \approx 03\text{H}$.
- Clear TA1FF to 0 and set it to invert on the match detects signal from TMRA1.
- Set P71 to function as the TA1OUT pin.
- Start TMRA1 counting.

X: Don't care, -: No change

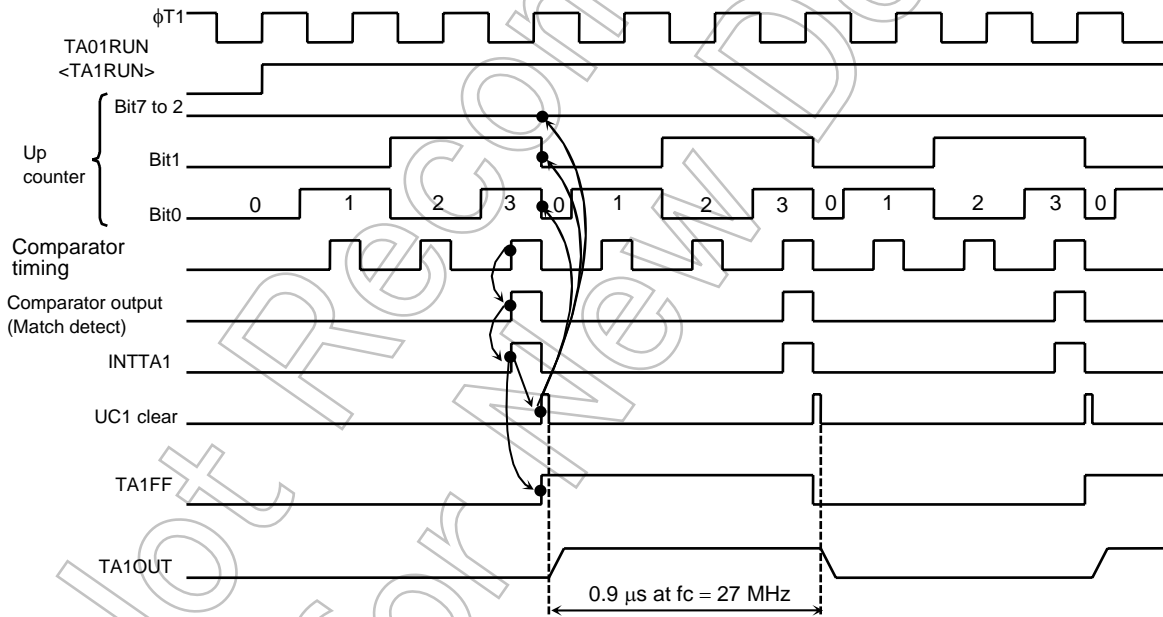

Figure 3.7.17 Square Wave Output Timing Chart (50% duty)

c. Making TMRA1 count up on the match signal from the TMRA0 comparator

Select 8-bit timer mode and set the comparator output from TMRA0 to be the input clock to TMRA1.

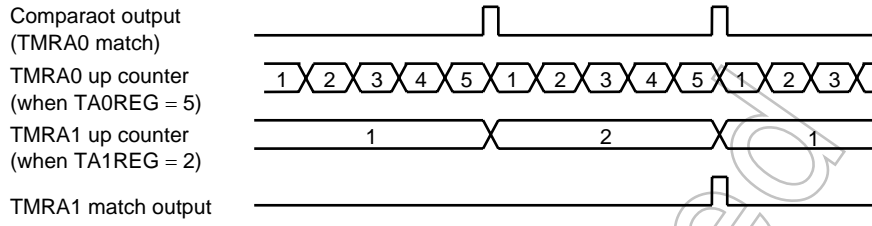

Figure 3.7.18 TMRA1 Count up on Signal from TMRA0

Not Recommended for New Design

(2) 16-bit timer mode

A 16-bit interval timer is configured by pairing the two 8-bit timers TMRA0 and TMRA1.

To make a 16-bit interval timer in which TMRA0 and TMRA1 are cascaded together, set TA01MOD<TA01M1:0> to 01.

In 16-bit timer mode, the overflow output from TMRA0 is used as the input clock for TMRA1, regardless of the value set in TA01MOD<TA01CLK1:0>. Table 3.7.2 shows the relationship between the timer (Interrupt) cycle and the input clock selection.

LSB 8 bits set to TA0REG and MSB 8 bits set to TA1REG. Please keep setting TA0REG first because setting data for TA0REG inhibit its compare function and setting data for TA1REG permit it.

Example: To generate an INTTA1 interrupt every 0.3 [s] at $f_c = 27$ MHz, set the timer registers TA0REG and TA1REG as follows:

* Clock state

System clock:	High frequency (f_c)
Clock gear:	1 (f_c)
Prescaler clock:	f_{FPH}

If ϕT_{16} ($(2^7/f_c)$ s at 27 MHz) is used as the input clock for counting, set the following value in the registers: $0.3 \text{ s} \div (2^7/f_c) \text{ s} \approx 62500 = \text{F424H}$

(e.g., set TA1REG to F4H and TA0REG to 24H).

As a result, INTTA1 interrupt can be generated every 0.29 [s].

The comparator match signal is output from TMRA0 each time the up counter UC0 matches TA0REG, though the up counter UC0 is not be cleared and also INTTA0 is not generated.

In the case of the TMRA1 comparator, the match detect signal is output on each comparator pulse on which the values in the up counter UC1 and TA1REG match. When the match detect signal is output simultaneously from both the comparators TMRA0 and TMRA1, the up counters UC0 and UC1 are cleared to 0 and the interrupt INTTA1 is generated. Also, if inversion is enabled, the value of the timer flip-flop TA1FF is inverted.

Example: When TA1REG = 04H and TA0REG = 80H

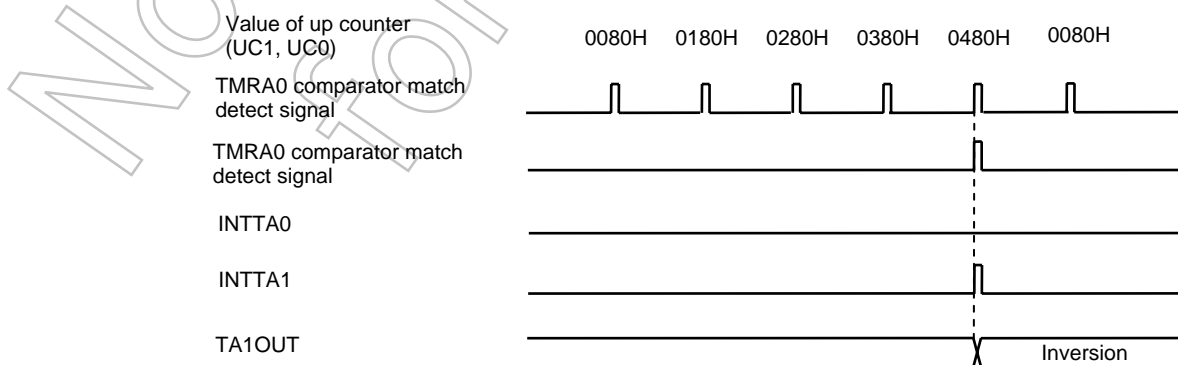

Figure 3.7.19 Timer Output by 16-Bit Timer Mode

(3) 8-bit PPG (Programmable pulse generation) output mode

Square wave pulses can be generated at any frequency and duty ratio by TMRA0. The output pulses may be active-Low or active-High. In this mode TMRA1 cannot be used.

TMRA0 outputs pulses on the TA1OUT pin.

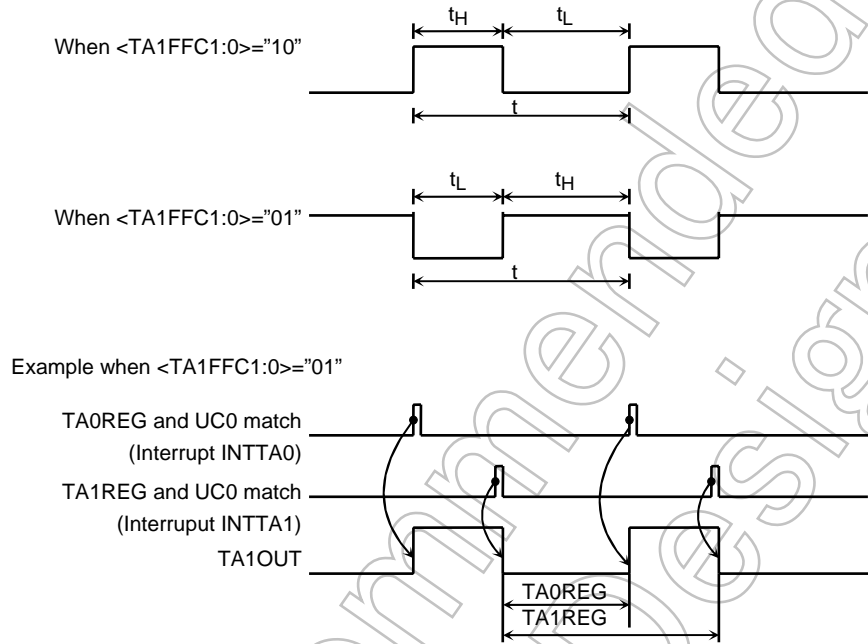

Figure 3.7.20 8-Bit PPG Output Waveforms

In this mode, a programmable square wave is generated by inverting the timer output each time the 8-bit up counter (UC0) matches the value in one of the timer registers TA0REG or TA1REG.

The value set in TA0REG must be smaller than the value set in TA1REG.

Although the up counter for TMRA1 (UC1) is not used in this mode, TA01RUN<TA1RUN> should be set to 1, so that UC1 is set for counting.

Figure 3.7.21 shows a block diagram representing this mode.

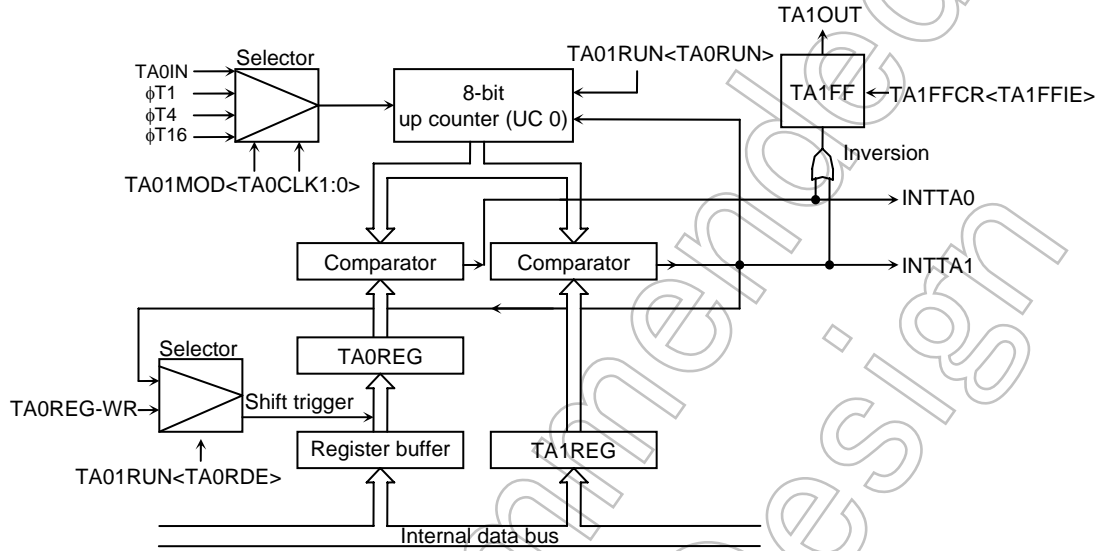

Figure 3.7.21 Block Diagram of 8-Bit PPG Output Mode

If the TA0REG double buffer is enabled in this mode, the value of the register buffer will be shifted into TA0REG each time TA1REG matches UC0.

Use of the double buffer facilitates the handling of low-duty waves (when duty is varied).

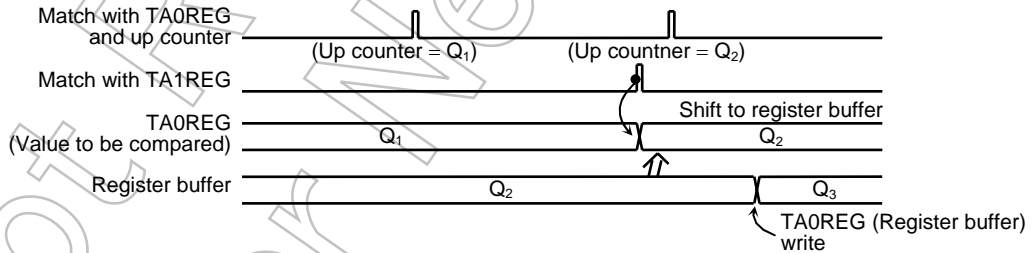
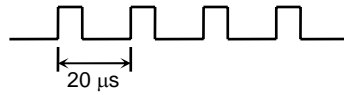

Figure 3.7.22 Operation of Register Buffer

Example: To generate 1/4-duty 50-kHz pulses (at $f_c = 27$ MHz)



* Clock state

System clock: High frequency (f_c)
 Clock gear: 1 (f_c)
 Prescaler clock: f_{PH}

Calculate the value which should be set in the timer register.

To obtain a frequency of 50 kHz, the pulse cycle t should be: $t = 1/50$ kHz = 20 μ s
 $\phi T1 = (2^3/f_c)s$ (at 27 MHz);

$$20 \mu s \div (2^3/f_c)s \approx 67$$

Therefore set TA1REG = 67 = 43H

The duty is to be set to 1/4: $t \times 1/4 = 20 \mu s \times 1/4 = 5 \mu s$

$$5 \mu s \div (2^3/f_c)s \approx 17$$

Therefore, set TA0REG = 17 = 11H.

	7	6	5	4	3	2	1	0	
TA01RUN	← -	X	X	X	-	0	0	0	Stop TMRA0 and TMRA01 and clear it to 0.
TA01MOD	← 1	0	X	X	X	X	0	1	Set the 8-bit PPG mode, and select $\phi T1$ as input clock.
TA0REG	← 0	0	0	1	0	0	0	1	Write 11H
TA1REG	← 0	1	0	0	0	0	1	1	Write 43H
TA1FFCR	← X	X	X	X	0	1	1	X	Set TA1FF, enabling both inversion and the double buffer.
						└───┬───┘			Writing 10 provides negative logic pulse.
PBCR	← X	-	-	-	-	-	1	-	} Set P71 as the TA1OUT pin.
PBFC	← X	-	-	-	-	-	1	X	
TA01RUN	← 1	X	X	X	-	1	1	1	Start TMRA0 and TMRA01 counting.

X: Don't care, -: No change

Not Recommended for New

(4) 8-bit PWM (Pulse width modulation) output mode

This mode is only valid for TMRA0. In this mode, a PWM pulse with the maximum resolution of 8 bits can be output.

When TMRA0 is used the PWM pulse is output on the TA1OUT pin. TMRA1 can also be used as an 8-bit timer.

The timer output is inverted when the up counter (UC0) matches the value set in the timer register TA0REG or when 2^n counter overflow occurs ($n = 6, 7$ or 8 as specified by TA01MOD<PWM01:00>). The up counter UC0 is cleared when 2^n counter overflow occurs.

The following conditions must be satisfied before this PWM mode can be used.

- Value set in TA0REG < Value set for 2^n counter overflow
- Value set in TA0REG $\neq 0$

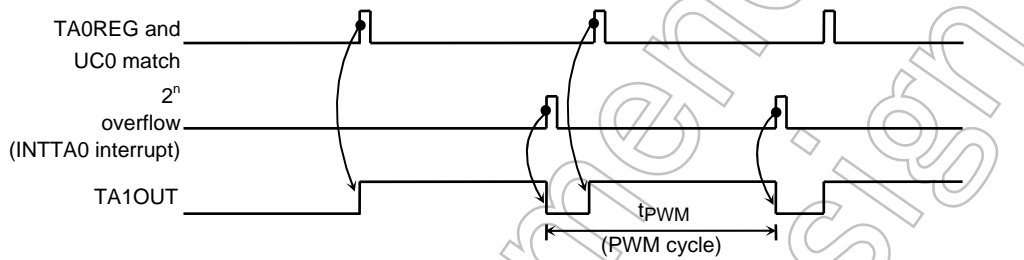

Figure 3.7.23 8-Bit PWM Waveforms

Figure 3.7.24 shows a block diagram representing this mode.

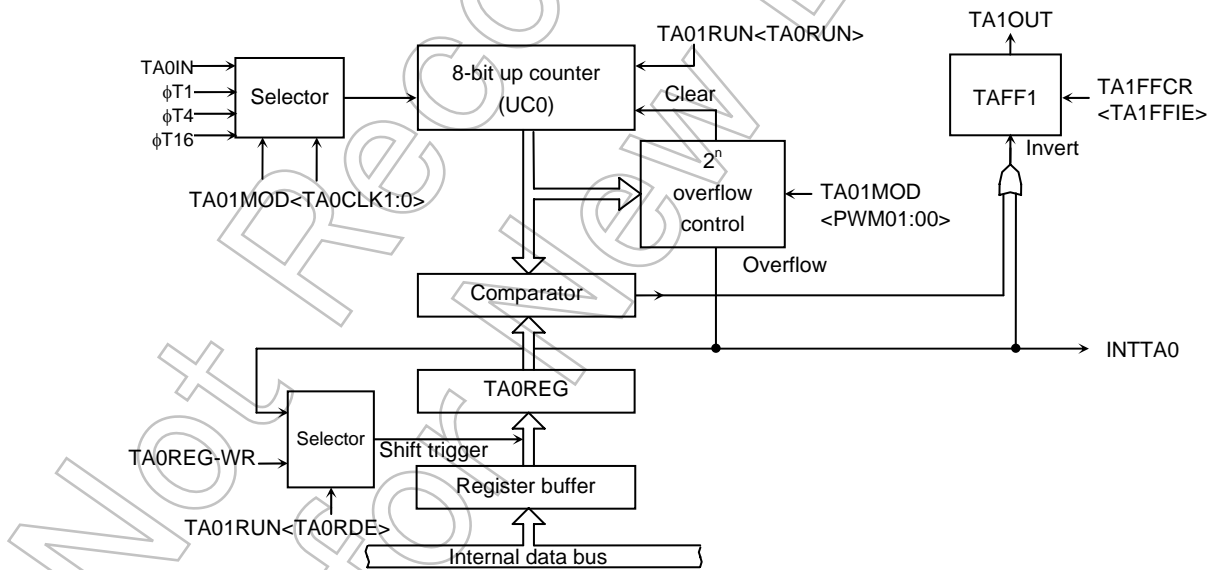

Figure 3.7.24 Block Diagram of 8-Bit PWM Mode

In this mode, the value of the register buffer will be shifted into TA0REG if 2ⁿ overflow is detected when the TA0REG double buffer is enabled.

Use of the double buffer facilitates the handling of low duty ratio waves.

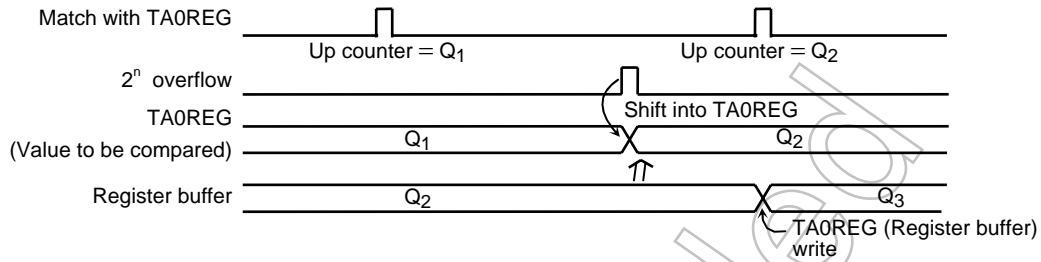
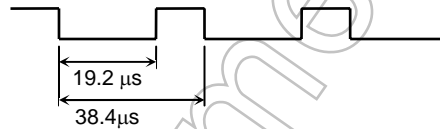

Figure 3.7.25 Register Buffer Operation

Example: To output the following PWM waves on the TA1OUT pin at $f_c = 27\text{MHz}$:



* Clock state

- System clock: High frequency (f_c)
- Clock gear: 1 (f_c)
- Prescaler clock: f_{PPH}

To achieve a 38.4 μs PWM cycle by setting $\phi T1 = (2^3/f_c) \text{ s}$ (at $f_c = 27 \text{ MHz}$):

$$38.4 \mu\text{s} \div (2^3/f_c) \text{ s} \approx 128 = 2^n$$

Therefore n should be set to 7.

Since the low-level period is 19.2 μs when $\phi T1 = (2^3/f_c) \text{ s}$, set the following value for TA0REG:

$$19.2 \mu\text{s} \div (2^3/f_c) \text{ s} \approx 64 = 40\text{H}$$

	MSB	7	6	5	4	3	2	1	LSB
TA01RUN	←	-	X	X	X	-	-	-	0
TA01MOD	←	1	1	1	0	X	X	0	1
TA0REG	←	0	1	0	0	1	0	1	0
TA1FFCR	←	X	X	X	X	1	0	1	X
PBCR	←	X	-	-	-	-	-	1	-
PBFC	←	X	-	-	-	X	-	1	X
TA01RUN	←	1	X	X	X	-	1	-	1

X: Don't care, -: No change

- Stop TMRA0 and clear it to 0.
- Select 8-bit PWM mode (Cycle: 2⁷) and select $\phi T1$ as the input clock.
- Write 40H.
- Clear TA1FF to 0, enable the inversion and double buffer.
- Set P71 and the TA1OUT pin.
- Start TMRA0 counting.

Table 3.7.3 PWM Cycle

at $f_c = 33 \text{ MHz}$, $f_s = 32.768 \text{ kHz}$

Select System Clock <SYSCK>	Select Prescaler Clock <PRCK1:0>	Gear Value <GEAR2:0>	PWM Cycle								
			2^6			2^7			2^8		
			$\phi T1$	$\phi T4$	$\phi T16$	$\phi T1$	$\phi T4$	$\phi T16$	$\phi T1$	$\phi T4$	$\phi T16$
1 (fs)		XXX	15.6 ms	62.5 ms	250 ms	31.3 ms	125.0 ms	500 ms	62.5 ms	250ms	1000 ms
0 (fc)	00 (fPH)	000 (fc)	19.0 μs	75.9 μs	303.4 μs	37.9 μs	151.7 μs	606.8 μs	75.9 μs	303.4 μs	1311 μs
		001 (fc/2)	37.9 μs	151.7 μs	606.8 μs	75.9 μs	303.4 μs	1213.6 μs	151.7 μs	606.8 μs	2621 μs
		010 (fc/4)	75.9 μs	303.4 μs	1213.6 μs	151.7 μs	606.8 μs	2427.3 μs	303.4 μs	1213.6 μs	5243 μs
		011 (fc/8)	151.7 μs	606.8 μs	2427.3 μs	303.4 μs	1213.6 μs	4854.5 μs	606.8 μs	2427.3 μs	9709.0 μs
		100 (fc/16)	303.4 μs	1213.6 μs	4854.5 μs	606.8 μs	2427.3 μs	9709.0 μs	1213.6 μs	4854.5 μs	19418 μs
		10 (fc/16 clock)	XXX	303.4 μs	1213.6 μs	4854.5 μs	606.8 μs	2427.3 μs	9709.0 μs	1213.6 μs	4854.5 μs

XXX: Don't care

(5) Settings for each mode

Table 3.7.4 shows the SFR settings for each mode.

Table 3.7.4 Timer Mode Setting Registers

Register Name	TA01MOD				TA1FFCR
	<TA01M1:0>	<PWM01:00>	<TA1CLK1:0>	<TA0CLK1:0>	TA1FFIS
Function	Timer Mode	PWM Cycle	Upper Timer Input Clock	Lower Timer Input Clock	Timer F/F Invert Signal Select
8-bit timer \times 2 channels	00	-	Lower timer match $\phi T1$, $\phi T16$, $\phi T256$ (00, 01, 10, 11)	External clock $\phi T1$, $\phi T4$, $\phi T16$ (00, 01, 10, 11)	0: Lower timer output 1: Upper timer output
16-bit timer mode	01	-	-	External clock $\phi T1$, $\phi T4$, $\phi T16$ (00, 01, 10, 11)	-
8-bit PPG \times 1 channel	10	-	-	External clock $\phi T1$, $\phi T4$, $\phi T16$ (00, 01, 10, 11)	-
8-bit PWM \times 1 channel	11	$2^6, 2^7, 2^8$ (01, 10, 11)	-	External clock $\phi T1$, $\phi T4$, $\phi T16$ (00, 01, 10, 11)	-
8-bit Timer \times 1 channel	11	-	$\phi T1$, $\phi T16$, $\phi T256$ (01, 10, 11)	-	Output disabled

--: Don't care

3.8 16-Bit Timer/Event Counters (TMRB)

The TMP91FY42 contains one multifunctional 16-bit timer/event counter (TMRB0) which has the following operation modes:

- 16-bit interval timer mode
- 16-bit event counter mode
- 16-bit programmable square wave pulse generation output mode (PPG: Variable duty cycle with variable period)

Can be used following operation modes by capture function:

- Frequency measurement mode
- Pulse width measurement mode
- Time differential measurement mode

Figure 3.8.1 and Figure 3.8.2 shows block diagram of TMRB0 and TMRB1. Timer/event counter consists of a 16-bit up counter, two 16-bit timer registers (One of them with a double-buffer structure), two 16-bit capture registers, two comparators, a capture input controller, a timer flip-flop and a control circuit.

Timer/Event counter is controlled by 11-byte control register (SFR).

2 channels (TMRB0 and TMRB1) can be used independently.

Both channels have the same operation except the Table 3.8.1 items. So, only the operation of TMRB0 will be explained below.

Table 3.8.1 Registers and Pins for TMRB0

Spec		Channel	TMRB0	TMRB1
External pin	External clock/ capture trigger input pin		TB0IN0 (Shared with P80)	TB1IN0 (Shared with P84)
			TB0IN1 (Shared with P81)	TB1IN1 (Shared with P85)
	Timer flip-flop output pin		TB0OUT0 (Shared with P82)	TB1OUT0 (Shared with P86)
			TB0OUT1 (Shared with P83)	TB1OUT1 (Shared with P87)
SFR name (Address)	Timer RUN register		TB0RUN (0180H)	TB1RUN (0190H)
	Timer mode register		TB0MOD (0182H)	TB1MOD (0192H)
	Timer flip-flop control register		TB0FFCR (0183H)	TB1FFCR (0193H)
	Timer register		TB0RG0L (0188H)	TB1RG0L (0198H)
			TB0RG0H (0189H)	TB1RG0H (0199H)
			TB0RG1L (018AH)	TB1RG1L (019AH)
			TB0RG1H (018BH)	TB1RG1H (019BH)
	Capture register		TB0CP0L (018CH)	TB1CP0L (019CH)
			TB0CP0H (018DH)	TB1CP0H (019DH)
			TB0CP1L (018EH)	TB1CP1L (019EH)
			TB0CP1H (018FH)	TB1CP1H (019FH)

3.8.1 Block Diagram of TMRB0

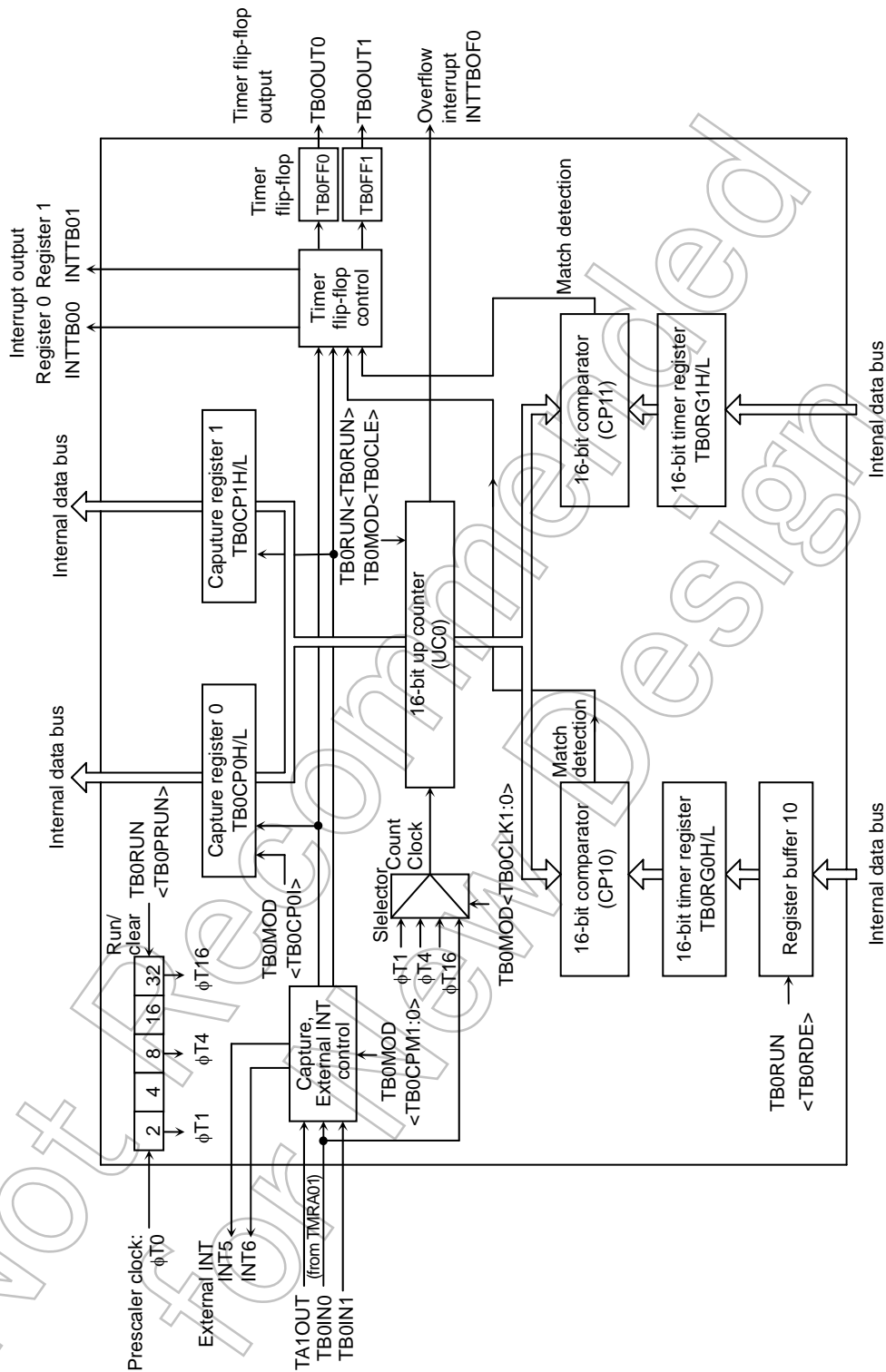

Figure 3.8.1 Block Diagram of TMRB0

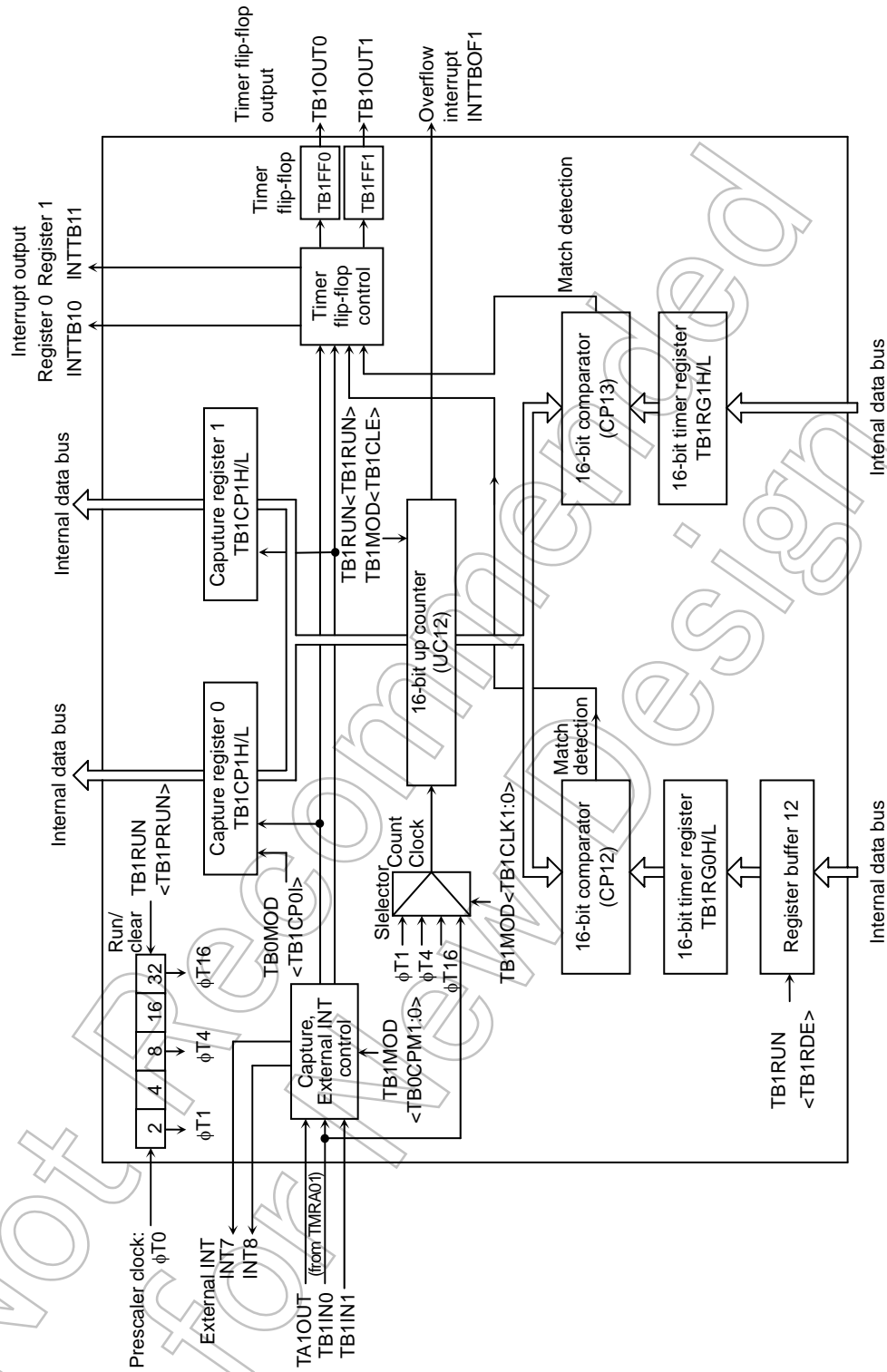

Figure 3.8.2 Block Diagram of TMRB1

3.8.2 Operation of Each Circuit

(1) Prescaler

The 5-bit prescaler generates the source clock for TMRB0. The prescaler clock ($\phi T0$) is divided clock (divided by 4) from selected clock by the register SYSCR0<PRCK1:0> of clock gear.

This prescaler can be started or stopped using TBORUN<TBOPRUN>. Counting starts when <TBOPRUN> is set to 1; the prescaler is cleared to zero and stops operation when <TBOPRUN> is cleared to 0.

Table 3.8.2 show prescaler output clock resolution.

Table 3.8.2 Prescaler Output Clock Resolution

@fc = 27 MHz, fs = 32.768 kHz

System Clock Selection <SYSCK>	Prescaler Clock Selection <PRCK1:0>	Clock Gear Value <GEAR2:0>	Prescaler Output Clock Resolution		
			$\phi T1$	$\phi T4$	$\phi T16$
1 (fs)		XXX	$2^3/fs$ (244 μ s)	$2^5/fs$ (977 μ s)	$2^7/fs$ (3.9 ms)
0 (fc)	00 (fFPH)	000 (fc)	$2^3/fc$ (0.3 μ s)	$2^5/fc$ (1.2 μ s)	$2^7/fc$ (4.7 μ s)
		001 (fc/2)	$2^4/fc$ (0.6 μ s)	$2^6/fc$ (2.4 μ s)	$2^8/fc$ (9.5 μ s)
		010 (fc/4)	$2^5/fc$ (1.2 μ s)	$2^7/fc$ (4.7 μ s)	$2^9/fc$ (19.0 μ s)
		011 (fc/8)	$2^6/fc$ (2.4 μ s)	$2^8/fc$ (9.4 μ s)	$2^{10}/fc$ (37.9 μ s)
		100 (fc/16)	$2^7/fc$ (4.7 μ s)	$2^9/fc$ (19.0 μ s)	$2^{11}/fc$ (75.9 μ s)
	10 (fc/16 clock)	XXX	$2^7/fc$ (4.7 μ s)	$2^9/fc$ (19.0 μ s)	$2^{11}/fc$ (75.9 μ s)

XXX: Don't care

(2) Up counter (UC0)

UC0 is a 16-bit binary counter which counts up according to input from the clock specified by TB0MOD<TB0CLK1:0> register.

As the input clock, one of the prescaler internal clocks $\phi T1$, $\phi T4$ and $\phi T16$ or an external clock from TB0IN0 pin can be selected. Counting or stopping and clearing of the counter is controlled by timer operation control register TBORUN<TBOPRUN>.

When clearing is enabled, the up counter UC0 will be cleared to 0 each time its value matches the value in the timer register TBORG1H/L. Clearing can be enabled or disabled using TB0MOD<TB0CLE>.

If clearing is disabled, the counter operates as a free-running counter.

A timer overflow interrupt (INTTBOF0) is generated when UC0 overflow occurs.

(3) Timer registers (TB0RG0H/L, TB0RG1H/L, TB1RG0H/L and TB1RG1H/L)

These two 16-bit registers are used to set the interval time. When the value in the up counter UC0 matches set value of timer register, the comparator match detect signal will be active.

Setting data for both upper and lower timer registers are always needed. For example, either using 2-byte data transfer instruction or using 1-byte data transfer instruction twice for lower 8 bits and upper 8 bits in order.

The TB0RG0H/L timer register has a double-buffer structure, which is paired with register buffer 0. The timer control register TB0RUN<TB0RDE> control whether the double buffer structure should be enabled or disabled: it is disabled when <TB0RDE> = 0, and enabled when <TB0RDE> = 1.

When the double buffer is enabled, data is transferred from the register buffer to the timer register when the values in the up counter (UC0) and the timer register TB0RG1 match.

After a Reset, TB0RG0H/L and TB0RG1 are undefined. To use the 16-bit timer after reset, data should be written beforehand.

When reset, <TB0RDE> is initialized to 0, whereby the double buffer is disabled. To use the double buffer, write data to the timer register, set <TB0RDE> to 1, then write following data to the register buffer.

TB0RG0H/L and the register buffer are allocated to the same memory address 0188H/0189H. When <TB0RDE> = 0, same value will be written to both the timer registers and register buffer. When <TB0RDE> = 1, the value is written into only the register buffer.

Therefore, when write initial value to timer register, set register buffer to disable.

The addresses of the timer registers are as follows:

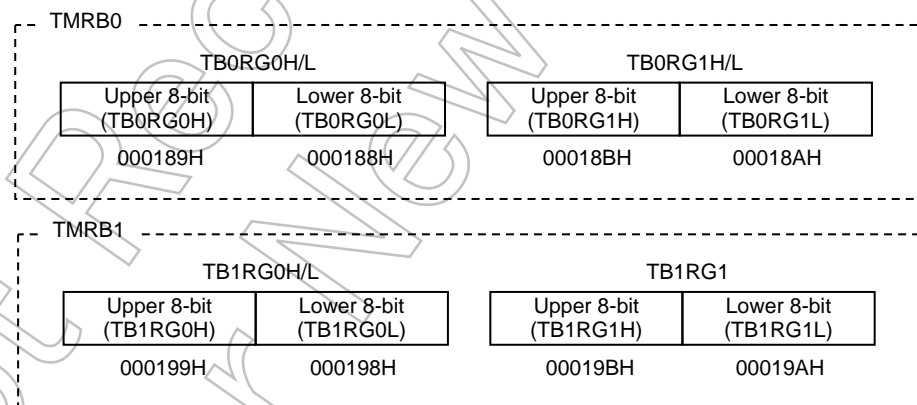

The TB0RG0H/L to TB1RG1H/L are write-only registers and thus cannot be read.

(4) Capture registers (TB0CP0H/L, TB0CP1H/L, TB1CP0H/L and TB1CP1H/L)

These 16-bit registers are used to latch the values of the up counters.

Data in the capture register should be read all 16 bits. For example, using 2-byte data load instruction or using 1-byte data load instruction twice for lower 8 bits and upper 8 bits in order.

The addresses of the capture registers are as follows:

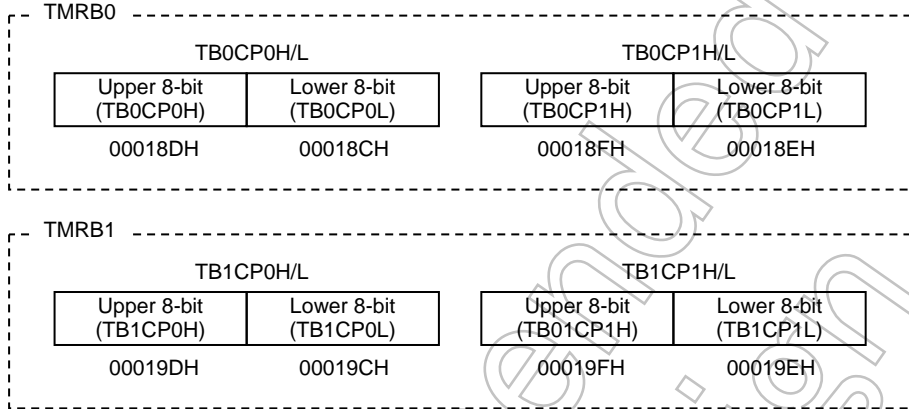

The TB0CP0H/L to TB1CP1H/L are read-only registers and thus cannot be read.

(5) Capture, external interrupts control

This circuit controls the timing to latch the value of up counter UC0 into TB0CP0H/L, TB0CP1H/L and control generation of external interrupt. The latch timing of capture register and selection of edge for external interrupt is set in TB0MOD<TB0CPM1:0>.

The edge of external interrupt INT6 is fixed to rising edge.

Besides, the value of up counter can be loaded into a capture registers by software. Whenever 0 is written to TB0MOD<TB0CP0I>, the current value in the up counter is loaded into capture register TB0CP0H/L. It is necessary to keep the prescaler in run mode (e.g., TB0RUN<TB0PRUN> must be held at a value of 1).

Note: As described above, whenever 0 is written to TB0MOD<TB0CP0I>, the current value in the up counter is loaded into capture register TB0CP0H/L. However, note that the current value in the up counter is also loaded into capture register TB0CP0H/L when 1 is written to TB0MOD<TB0CP0I> while this bit is holding 0.

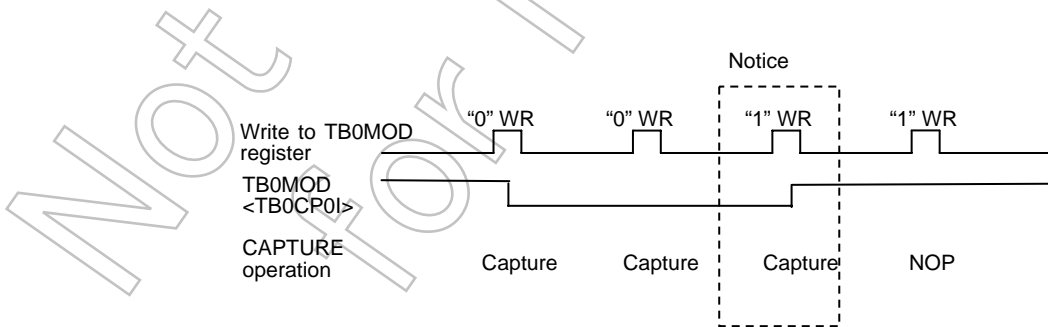

(6) Comparators (CP10 and CP11, CP12 and CP13)

CP0 and CP1 are 16-bit comparators which compare the value in the up counter UC0 value with the value set of TB0RG0H/L or TB0RG1H/L respectively, in order to detect a match. If a match is detected, the comparators generate an interrupt (INTTB00 or INTTB01 respectively).

(7) Timer flip-flops (TB0FF0 and TB0FF1)

These flip-flops are inverted by the match detect signals from the comparators and the latch signals to the capture registers. Inversion can be enabled and disabled for each element using TB0FFCR<TB0C1T1, TB0C0T1, TB0E1T1, TB0E0T1>.

After a reset, the value of TB0FF0 and TB0FF1 is undefined. If "00" is written to TB0FFCR<TB0FF0C1:0> or <TB0FF1C1:0>, TB0FF0 or TB0FF1 will be inverted. If "01" is written to the flip-flops control registers, the value of TB0FF0 and TB0FF1 will be set to "1". If "10" is written to the flip-flops control registers, the value of TB0FF0 and TB0FF1 will be cleared to "0".

The values of TB0FF0 and TB0FF1 can be output to the timer output pins TB0OUT0 (which is shared with P82), TB0OUT1 (which is shared with P83). Timer output should be specified by using the port 8 function register P8FC and port 8 control register P8CR.

Not Recommended for New Designs

3.8.3 SFR

TMRB0 RUN Register

	7	6	5	4	3	2	1	0
Bit symbol	TB0RDE	–			I2TB0	TB0PRUN		TB0RUN
Read/Write	R/W				R/W			R/W
After reset	0	0			0	0		0
Function	Double buffer 0: Disable 1: Enable	Always write "0".			IDLE2 0: Stop 1: Operation	TMRB0 prescaler 0: Stop and clear 1: Run (Count up)		Up counter (UC10)

Count operation

0	Stop and clear
1	Count

Note: The values of bits 1, 4 and 5 of TB0RUN are undefined when read.

TMRB1 RUN Register

	7	6	5	4	3	2	1	0
Bit symbol	TB1RDE	–			I2TB1	TB1PRUN		TB1RUN
Read/Write	R/W				R/W			R/W
After reset	0	0			0	0		0
Function	Double buffer 0: Disable 1: Enable	Always write "0".			IDLE2 0: Stop 1: Operation	TMRB1 prescaler 0: Stop and clear 1: Run (Count up)		Up counter (UC12)

Count operation

0	Stop and clear
1	Count

Note: The values of bits 1, 4 and 5 of TB1RUN are undefined when read.

Figure 3.8.3 Register for TMRB

TMRB0 Mode Register

	7	6	5	4	3	2	1	0
Bit symbol	TB0CT1	TB0ET1	TB0CP0I	TB0CPM1	TB0CPM0	TB0CLE	TB0CLK1	TB0CLK0
Read/Write	R/W		W*	R/W				
After reset	0	0	1	0	0	0	0	0
Function	TB0FF1 Inversion trigger 0: Trigger disable 1: Trigger enable		Software capture control 0: Software capture 1: Undefined	Capture timing 00: Disable INT5 is rising edge 01: TB0IN0 ↑ TB0IN1 ↑ INT5 is rising edge 10: TB0IN0 ↑ TB0IN0 ↓ INT5 is falling edge 11: TA1OUT ↑ TA1OUT ↓ INT5 is rising edge		Up counter control 0: Clear disable 1: Clear enable	TMRB0 source clock select 00: TB0IN0 pin input 01: φT1 10: φT4 11: φT16	
	Invert when capture to capture register 1	Invert when match UC0 with timer register 1						

Read-Modify-write instruction is prohibited

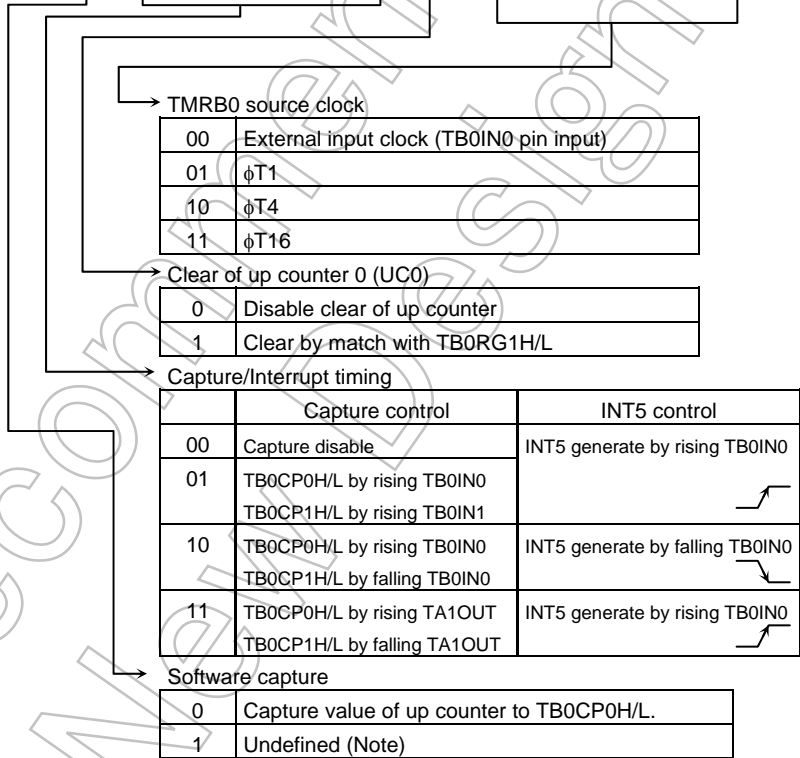

Note: Whenever programming "0" to TB0MOD<TB0CP0I> bit, present value of up counter is received to capture register TB0CP0H/L. But, write "1" to TB0MOD<TB0CP0I> in condition of written "0" to TB0MOD<TB0CP0I> bit, present value of up counter is received to capture register TB0CP0H/L. Therefore you must to regard.

Figure 3.8.4 Register for TMRB

TMRB1 Mode Register

	7	6	5	4	3	2	1	0
Bit symbol	TB1CT1	TB1ET1	TB1CP0I	TB1CPM1	TB1CPM0	TB1CLE	TB1CLK1	TB1CLK0
Read/Write	R/W		W*	R/W				
After reset	0	0	1	0	0	0	0	0
Function	TB1FF1 Inversion trigger 0: Trigger disable 1: Trigger enable		Software capture control 0: Software capture 1: Undefined	Capture timing 00: Disable INT7 is rising edge 01: TB1IN0 ↑ TB1IN1 ↑ INT7 is rising edge 10: TB1IN0 ↑ TB1IN0 ↓ INT75 is falling edge 11: TA1OUT ↑ TA1OUT ↓ INT7 is rising edge		Up counter control 0: Clear disable 1: Clear enable	TMRB1 source clock select 00: TB1IN0 pin input 01: φT1 10: φT4 11: φT16	
Invert when capture to register 1	Invert when match UC12 with register 1							

Read-Modify-write instruction is prohibited

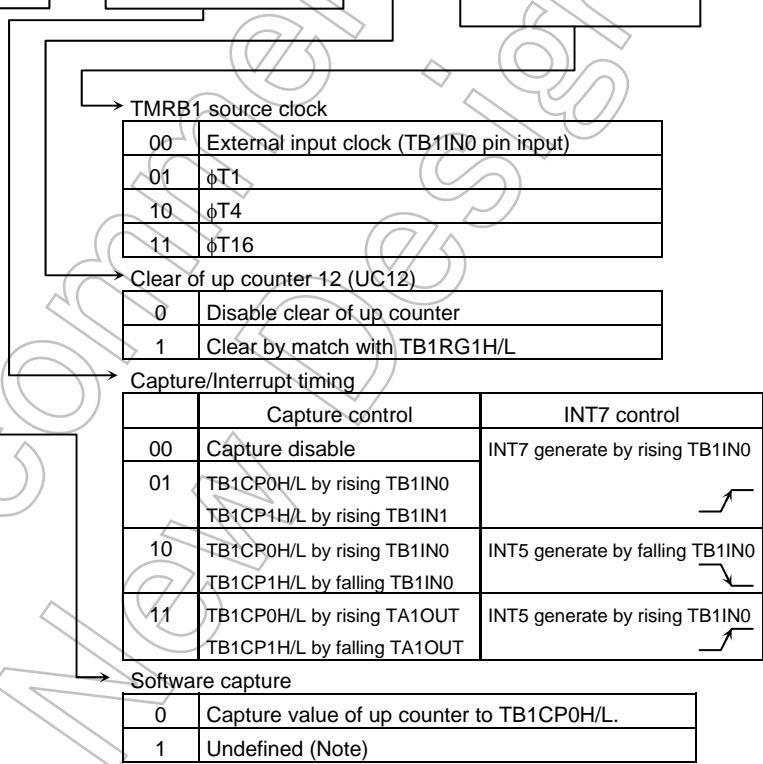

Note: Whenever programming "0" to TB1MOD<TB1CP0I> bit, present value of up counter is received to capture register TB1CP0H/L. But, write "1" to TB1MOD<TB1CP0I> in condition of written "0" to TB1MOD<TB1CP0I> bit, present value of up counter is received to capture register TB1CP0H/L. Therefore you must to regard.

Figure 3.8.5 Register for TMRB

TMRB0 Flip-Flop Control Register

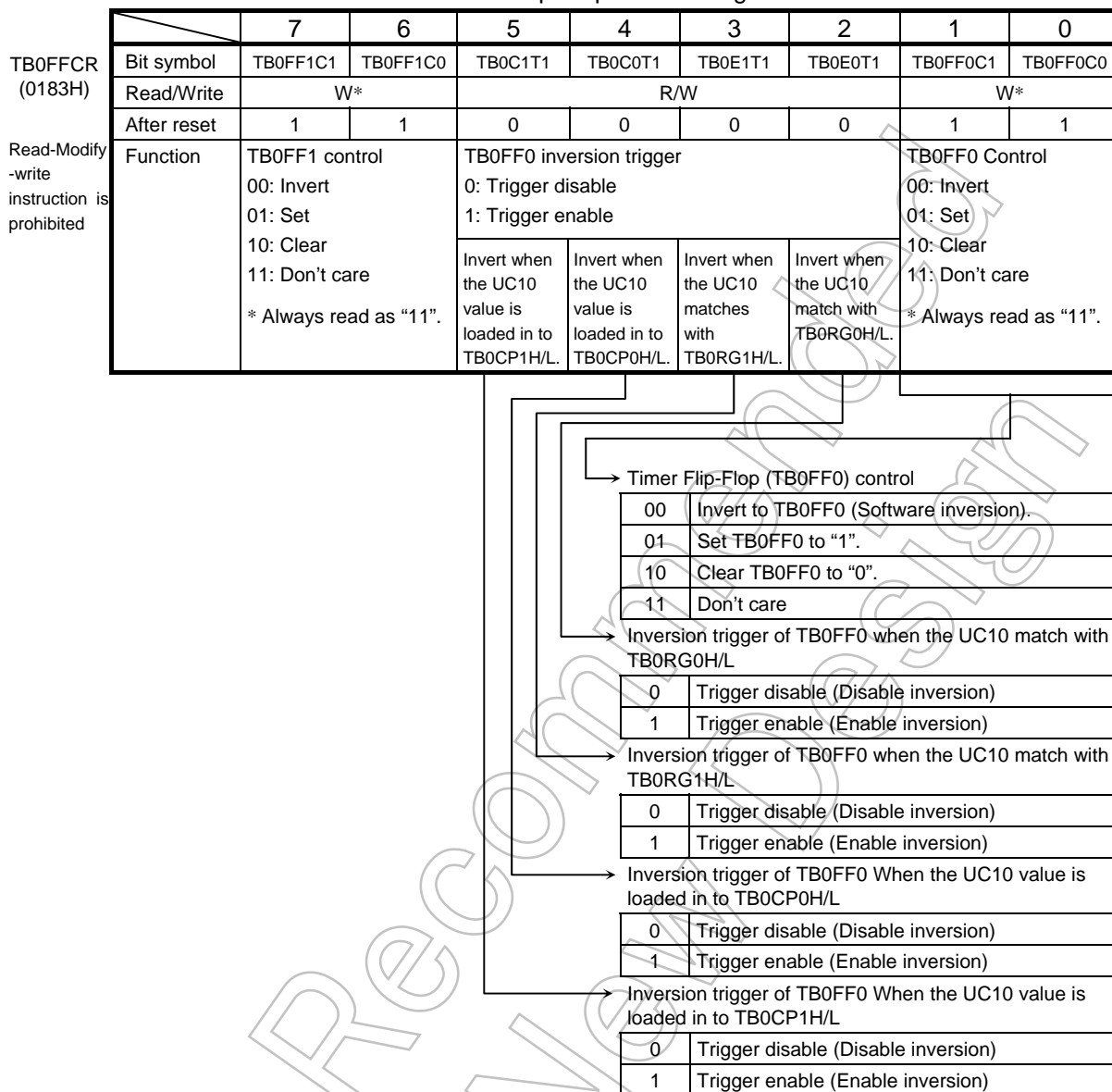

Figure 3.8.6 Register for TMRB

TMRB1 Flip-Flop Control Register

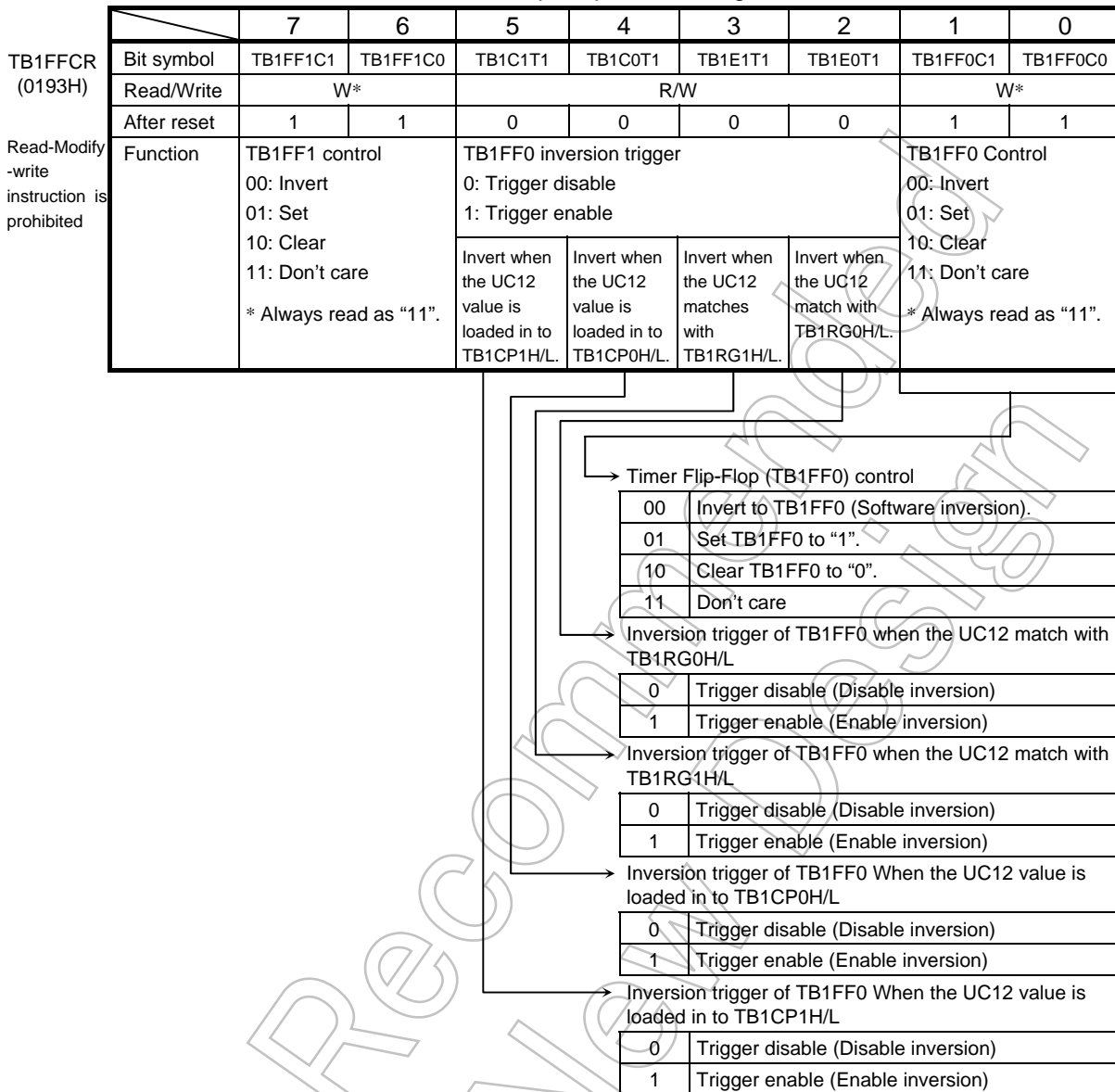

Figure 3.8.7 Register for TMRB

		7	6	5	4	3	2	1	0
TB0RG0L (0188H)	bit Symbol					-			
	Read/Write					W			
	After reset					Undefined			
TB0RG0H (0189H)	bit Symbol					-			
	Read/Write					W			
	After reset					Undefined			
TB0RG1L (018AH)	bit Symbol					-			
	Read/Write					W			
	After reset					Undefined			
TB0RG1H (018BH)	bit Symbol					-			
	Read/Write					W			
	After reset					Undefined			
TB1RG0L (0198H)	bit Symbol					-			
	Read/Write					W			
	After reset					Undefined			
TB1RG0H (0199H)	bit Symbol					-			
	Read/Write					W			
	After reset					Undefined			
TB1RG1L (019AH)	bit Symbol					-			
	Read/Write					W			
	After reset					Undefined			
TB1RG1H (019BH)	bit Symbol					-			
	Read/Write					W			
	After reset					Undefined			

Note: The above registers are prohibited read-modify-write instruction.

Figure 3.8.8 Register for TMRB

3.8.4 Operation in Each Mode

(1) 16-bit interval timer mode

Generating interrupts at fixed intervals

In this example, the interval time is set the timer register TB0RG1H/L to generate the interrupt INTTB01.

	7	6	5	4	3	2	1	0		
TB0RUN	←	-	0	X	X	-	0	X	0	Stop TMRB0.
INTETB0	←	X	1	0	0	X	0	0	0	Enable INTTB01 and set interrupt level 4. Disable INTTB00.
TB0FFCR	←	1	1	0	0	0	0	1	1	Disable the trigger.
TB0MOD	←	0	0	1	0	0	1	*	*	Select source clock and Disable the capture function.
						(** = 01, 10, 11)				
TB0RG1	←	*	*	*	*	*	*	*	*	Set the interval time.
		*	*	*	*	*	*	*	*	(16 bits)
TB0RUN	←	0	0	X	X	-	1	X	1	Start TMRB0.

X: Don't care, -: No change

(2) 16-bit event counter mode

In 16-bit timer mode as described in above, the timer can be used as an event counter by selecting the external clock (TB0IN0 pin input) as the input clock.

Up counter counting up by rising edge of TB0IN0 pin input. And execution software capture and reading capture value enable reading count value.

	7	6	5	4	3	2	1	0		
TB0RUN	←	-	0	X	X	-	0	X	0	Stop TMRB0.
P8CR	←	X	X	X	X	-	-	-	0	} Set P80 to TB0IN0 input mode.
P8FC	←	X	X	X	X	-	-	-	1	
INTETB0	←	X	1	0	0	X	0	0	0	
TB0FFCR	←	1	1	0	0	0	0	1	1	Disable trigger.
TB0MOD	←	0	0	1	0	0	1	0	0	Set input clock to TB0IN0 pin input.
TB0RG1	←	*	*	*	*	*	*	*	*	Set number of count.
		*	*	*	*	*	*	*	*	(16 bits)
TB0RUN	←	0	0	X	X	-	1	X	1	Start TMRB0.

X: Don't care, -: No change

When used as an event counter, set the prescaler to "RUN".

(TB0RUN<TB0PRUN> = "1")

(3) 16-bit programmable pulse generation (PPG) output mode

Square wave pulses can be generated at any frequency and duty ratio. The output pulse may be either low active or high active.

The PPG mode is obtained by inversion of the timer flip-flop TB0FF0 that is to be enabled by the match of the up counter UC0 with timer register TB0RG0H/L or TB0RG1H/L and to be output to TB0OUT0. In this mode, the following conditions must be satisfied.

$$(\text{Set value of TB0RG0H/L}) < (\text{Set value of TB0RG1H/L})$$

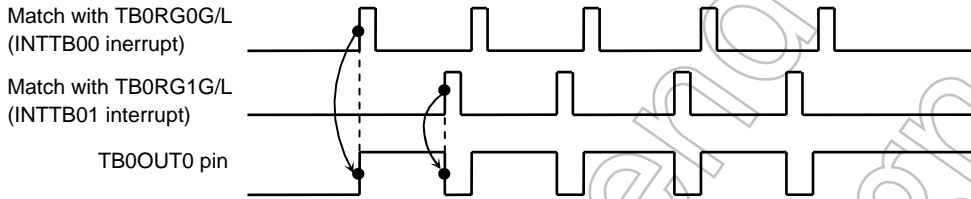

Figure 3.8.9 Programmable Pulse Generation (PPG) Output Waveforms

When the TB0RG0H/L double buffer is enabled in this mode, the value of register buffer 0 will be shifted into TB0RG0H/L at match with TB0RG1H/L. This feature makes easy the handling of low-duty waves.

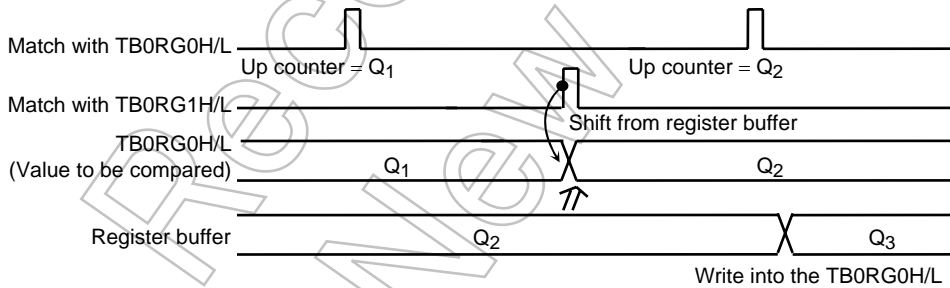

Figure 3.8.10 Operation of Register Buffer

The following block diagram illustrates this mode.

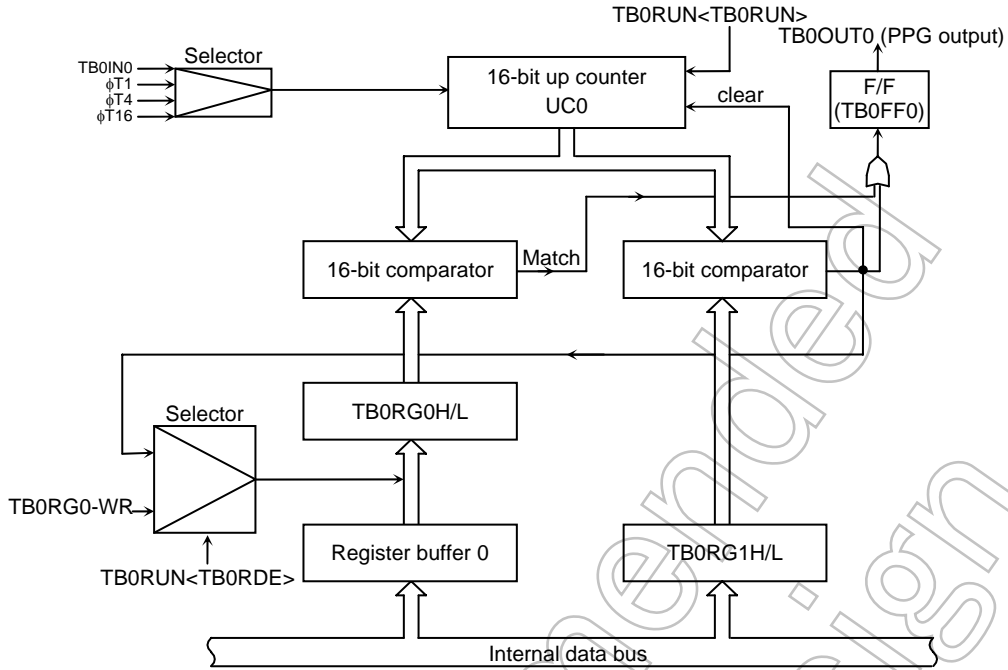

Figure 3.8.11 Block Diagram of 16-Bit PPG Mode

The following example shows how to set 16-bit PPG output mode:

	7	6	5	4	3	2	1	0	
TB0RUN	← 0	0	X	X	-	0	X	0	Disable the TB0RG0 double buffer and stop TMRB0.
TB0RG0	← *	*	*	*	*	*	*	*	Set the duty ratio. (16 bits)
TB0RG1	← *	*	*	*	*	*	*	*	Set the frequency. (16 bits)
TB0RUN	← 1	0	X	X	-	0	X	0	Enable the TB0RG0H/L double buffer. (The duty and frequency are changed on an INTTB01 Interrupt.)
TB0FFCR	← X	X	0	0	1	1	1	0	Set the mode to invert TB0FF0 at the match with TB0RG0H/L/TB0RG1H/L. Clear TB0FF0 to 0.
TB0MOD	← 0	0	1	0	0	1	*	*	Select the source clock and disable the capture function. (** = 01, 10, 11)
P8CR	← X	X	X	X	-	1	-	-	} Set P82 to function as TB0OUT0.
P8FC	← X	X	X	X	-	1	-	-	
TB0RUN	← 1	0	X	X	-	1	X	1	

X: Don't care, -: No change

(4) Capture function examples

Used capture function, they can be applicable in many ways, for example:

- a. One-shot pulse output from external trigger pulse
- b. For frequency measurement
- c. For pulse width measurement
- d. For time difference measurement

a. One-shot pulse output from external trigger pulse

Set the up counter UC0 in free-running mode with the internal input clock, input the external trigger pulse from TB0IN0 pin, and load the value of up-counter into capture register TB0CP0H/L at the rise edge of the TB0IN0 pin.

When the interrupt INT5 is generated at the rise edge of TB0IN0 input, set the TB0CP0H/L value (c) plus a delay time (d) to TB0RG0H/L ($= c + d$), and set the above set value (c + d) plus a one-shot width (p) to TB0RG1H/L ($= c + d + p$). And, set "11" to timer flip-flop control register TB0FFCR<TB0E1T1, TB0E0T1>. Set to trigger enable for be inverted timer flip-flop TB0FF0 by UC0 matching with TB0RG0H/L and with TB0RG1H/L. When interrupt INTTB01 occurs, this inversion will be disabled after one-shot pulse is output.

The (c), (d) and (p) correspond to c, d and p Figure 3.8.12.

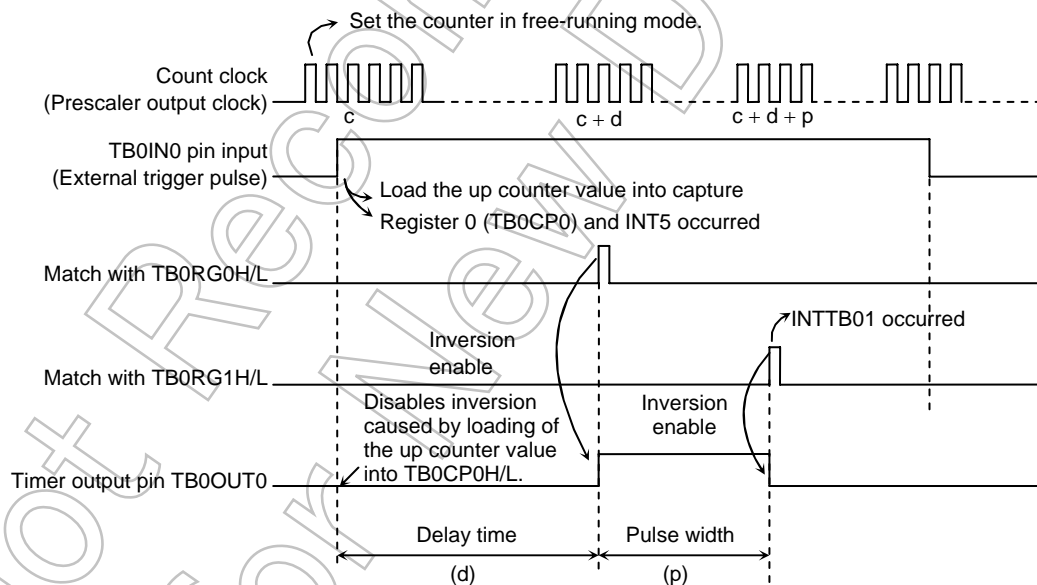

Figure 3.8.12 One-shot Pulse Output (with delay)

Example: To output a 2-ms one-shot pulse with a 3-ms delay to the external trigger pulse via the TB0IN0 pin.

* Clock state
 System clock: High frequency (fc)
 Clock gear: 1 (fc)
 Prescaler clock: f_{PPH}

Main setting

TB0MOD	←	X	X	1	0	1	0	0	1	→	Set free running. Count using φT1.
TB0FFCR	←	X	X	0	0	0	0	1	0	→	Load the up counter value into TB0CP0H/L at the rising edge of TB0IN0 pin input. Clear TB0FF0 to 0. Disable inversion of TB0FF0.
P8CR	←	X	X	X	X	-	1	-	0	}	Set P82 to function as the TB0OUT0 pin. Set P80 to TB0IN0 input mode.
P8FC	←	X	X	X	X	-	1	-	1		
INTE56	←	X	-	-	-	X	1	0	0	}	Enable INT5. Disable INTTB00 and INTTB01.
INTETB0	←	X	0	0	0	X	0	0	0		
TB0RUN	←	-	0	X	X	-	1	X	1		

X: Don't care, -: No change

Setting in INT5

TB0RG0	←	TB0CP0 + 3ms/φT1									
TB0RG1	←	TB0RG0 + 2ms/φT1									
TB0FFCR	←	X	X	-	-	1	1	-	-	→	Enable inversion of TB0FF0 when the up counter value match with value of TB0RG0H/L or TB0RG1H/L.
INTETB0	←	X	1	0	0	X	-	-	-	→	Enable INTTB01.

X: Don't care, -: No change

Setting in INTTB01

TB0FFCR	←	X	X	-	-	0	0	-	-	→	Disable inversion of TB0FF0 when the up counter value match with value of TB0RG0H/L or TB0RG1H/L.
INTETB0	←	X	0	0	0	X	-	-	-	→	Disable INTTB01.

X: Don't care, -: No change

When delay time is unnecessary, invert timer flip-flop TB0FF0 when up-counter value is loaded into capture register (TB0CP0H/L), and set the TB0CP0H/L value (c) plus the one-shot pulse width (p) to TB0RG1H/L when the interrupt INT5 occurs. The TB0FF0 inversion should be enable when the up counter (UC0) value matches TB0RG1H/L, and disabled when generating the interrupt INTTB01.

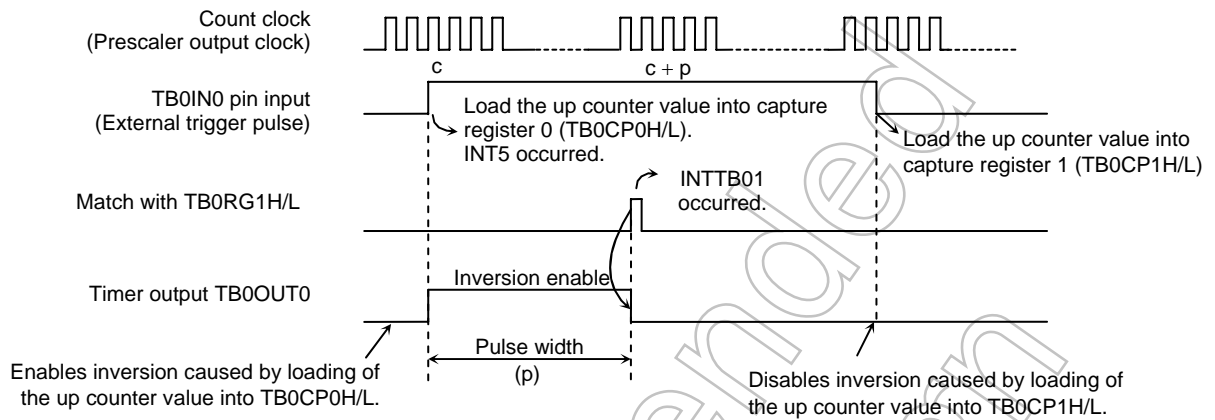

Figure 3.8.13 One-shot Pulse Output of External Trigger Pulse (without delay)

b. Frequency measurement

The frequency of the external clock can be measured in this mode. The clock is input through the TB0IN0 pin, and its frequency is measured by the 8-bit timers TMRA01 and the 16-bit timer/event counter (TMRB0). (TMRA01 is used to setting of measurement time by inversion TA1FF.)

The TB0IN0 pin input should be for the input clock of TMRB0. Set to TB0MOD <TB0CPM1:0> = "11". The value of the up counter (UC0) is loaded into the capture register TB0CP0H/L at the rise edge of the timer flip-flop TA1FF of 8-bit timers (TMRA01), and into TB0CP1H/L at its fall edge.

The frequency is calculated by difference between the loaded values in TB0CP0H/L and TB0CP1H/L when the interrupt (INTTA0 or INTTA1) is generates by either 8-bit timer.

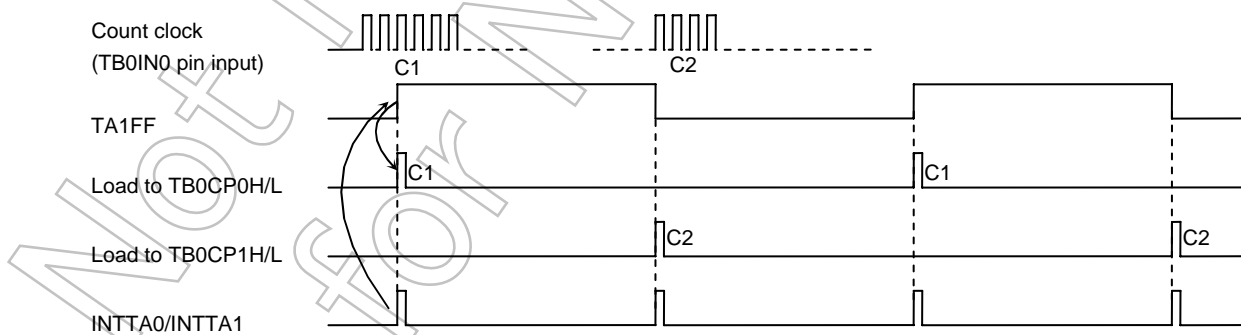

Figure 3.8.14 Frequency Measurement

For example, if the value for the level 1 width of TA1FF of the 8-bit timer is set to 0.5 s and the difference between the values in TB0CP0H/L and TB0CP1H/L is 100, the frequency is $100 \div 0.5 \text{ s} = 200 \text{ Hz}$.

c. Pulse width measurement

This mode allows to measure the high-level width of an external pulse. While keeping the 16-bit timer/event counter counting (Free running) with the internal clock input, external pulse is input through the TB0IN0 pin. Then the capture function is used to load the UC0 values into TB0CP0H/L and TB0CP1H/L at the rising edge and falling edge of the external trigger pulse respectively. The interrupt INT5 occurs at the falling edge of TB0IN0.

The pulse width is obtained from the difference between the values of TB0CP0H/L and TB0CP1H/L and the internal clock cycle.

For example, if the internal clock is $0.8 \mu\text{s}$ and the difference between TB0CP0H/L and TB0CP1H/L is 100, the pulse width will be $100 \times 0.8 \mu\text{s} = 80 \mu\text{s}$.

Additionally, the pulse width which is over the UC0 maximum count time specified by the clock source, can be measured by changing software.

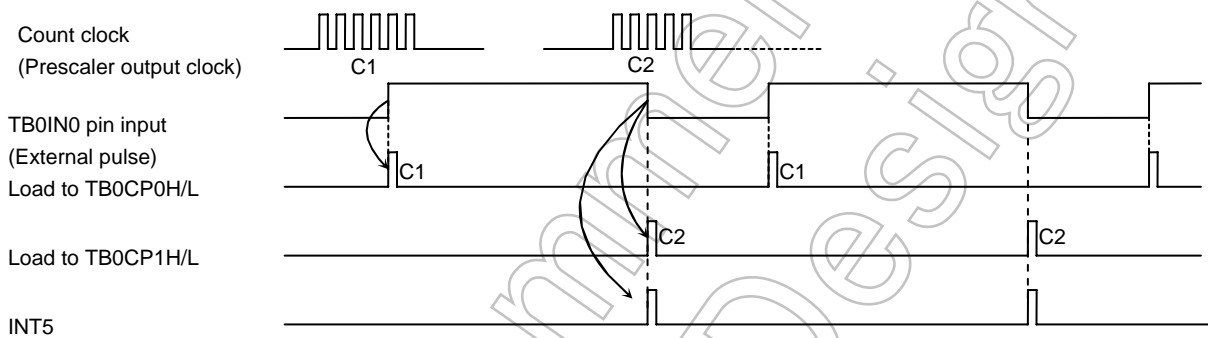

Figure 3.8.15 Pulse Width Measurement

Note: Pulse width measure by setting "10" to TB0MOD<TB0CPM1:0>. The external interrupt INT5 is generated in timing of falling edge of TB0IN0 input. In other modes, it is generated in timing of rising edge of TB0IN0 input.

The width of low-level can be measured from the difference between the first C2 and the second C1 at the second INT5 interrupt.

d. Measurement of difference time

This mode is used to measure the difference in time between the rising edges of external pulses input through TB0IN0 and TB0IN1.

Keep the 16-bit timer/event counter (TMRB0) counting (Free running) with the internal clock, and load the UC0 value into TB0CP0H/L at the rising edge of the input pulse to TB0IN0. Then the interrupt INT5 is generated.

Similarly, the UC0 value is loaded into TB0CP1H/L at the rising edge of the input pulse to TB0IN1, generating the interrupt INT6.

The time difference between these pulses can be obtained by multiplying the value subtracted TB0CP0H/L from TB0CP1H/L and the internal clock cycle together at which loading the up counter value into TB0CP0H/L and TB0CP1H/L has been done.

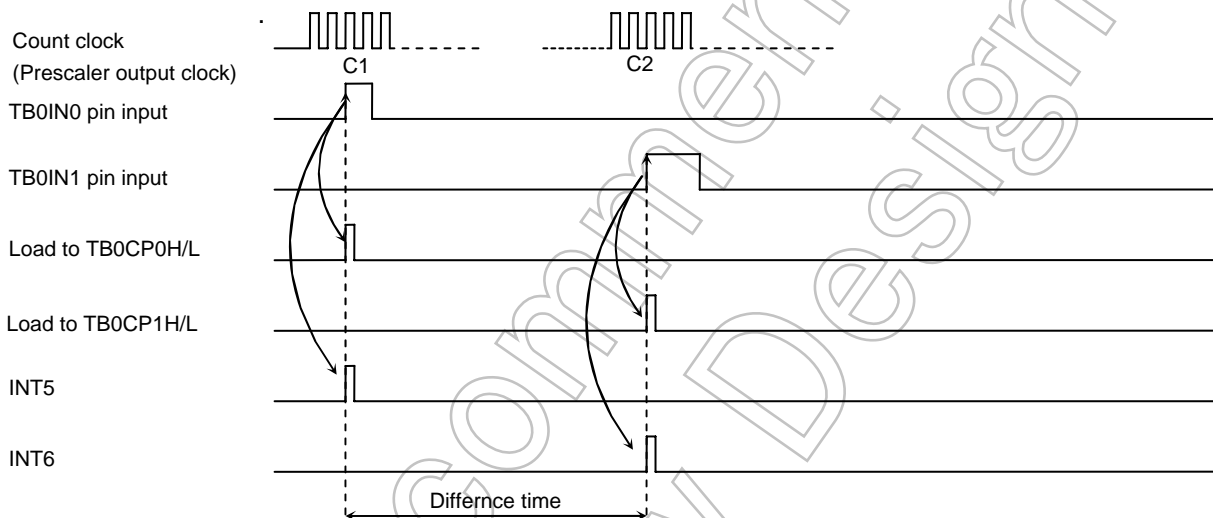

Figure 3.8.16 Measurement of Difference Time

3.9 Serial Channels

TMP91FY42 includes 2 serial I/O channels. For both channels either UART mode (Asynchronous transmission) or I/O interface mode (Synchronous transmission) can be selected.

- I/O interface mode — Mode 0: For transmitting and receiving I/O data using the synchronizing signal SCLK for extending I/O.
- UART mode — Mode 1: 7-bit data
 — Mode 2: 8-bit data
 — Mode 3: 9-bit data

In mode 1 and mode 2, a parity bit can be added. Mode 3 has a wakeup function for making the master controller start slave controllers via a serial link (A multi-controller system).

Figure 3.9.2, Figure 3.9.3 are block diagrams for each channel.

Serial channels 0 and 1 can be used independently.

Both channels operate in the same fashion except for the following points; hence only the operation of channel 0 is explained below.

Table 3.9.1 Differences between Channels 0 to 1

	Channel 0	Channel 1
Pin Name	TXD0 (P90) RXD0 (P91) CTS0 /SCLK0 (P92)	TXD1 (P93) RXD1 (P94) CTS1 /SCLK1 (P95)
IrDA Mode	Yes	No

This chapter contains the following sections:

- 3.9.1 Block Diagrams
- 3.9.2 Operation of Each Circuit
- 3.9.3 SFRs
- 3.9.4 Operation in Each Mode
- 3.9.5 Support for IrDA

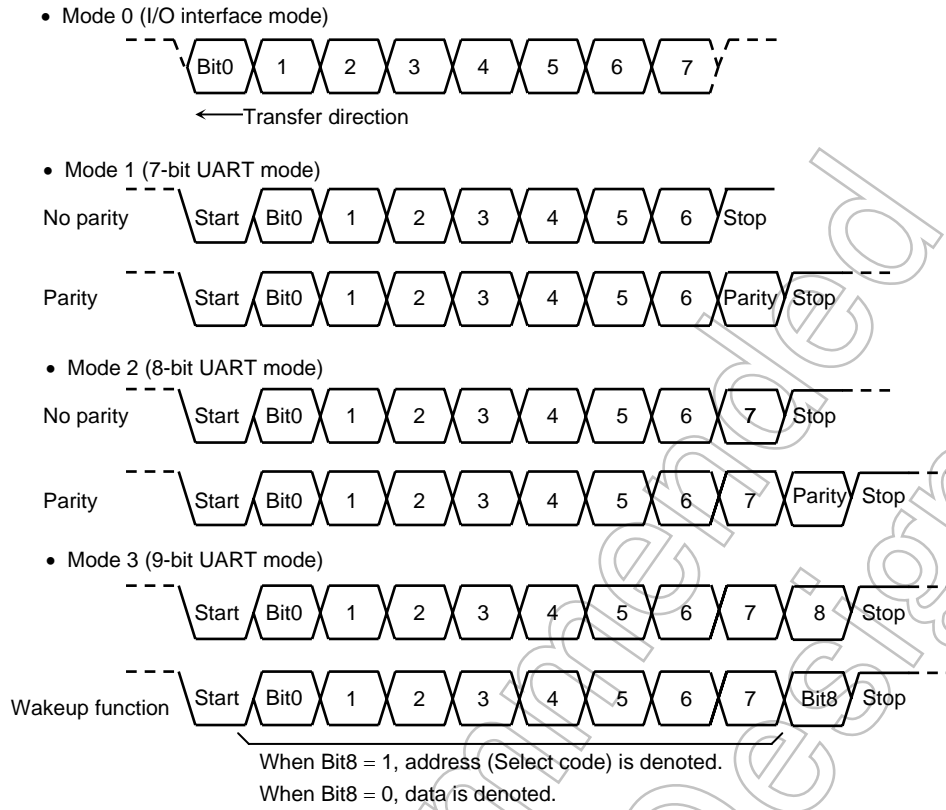

Figure 3.9.1. Data Formats

Not Recommended for New

3.9.1 Block Diagrams

Figure 3.9.2 is a block diagram representing serial channel 0.

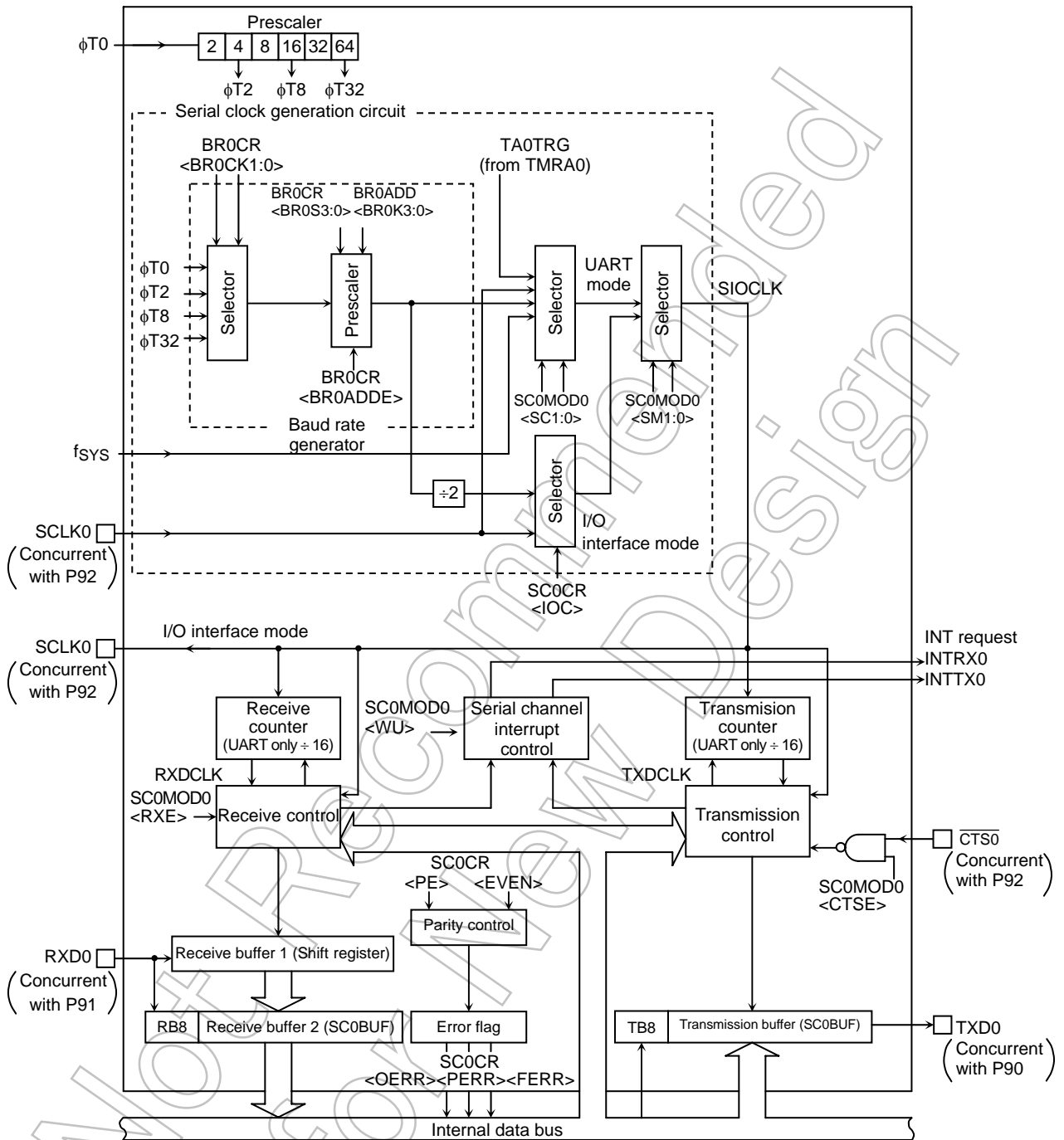

Figure 3.9.2 Block Diagram of the Serial Channel 0 (SIO0)

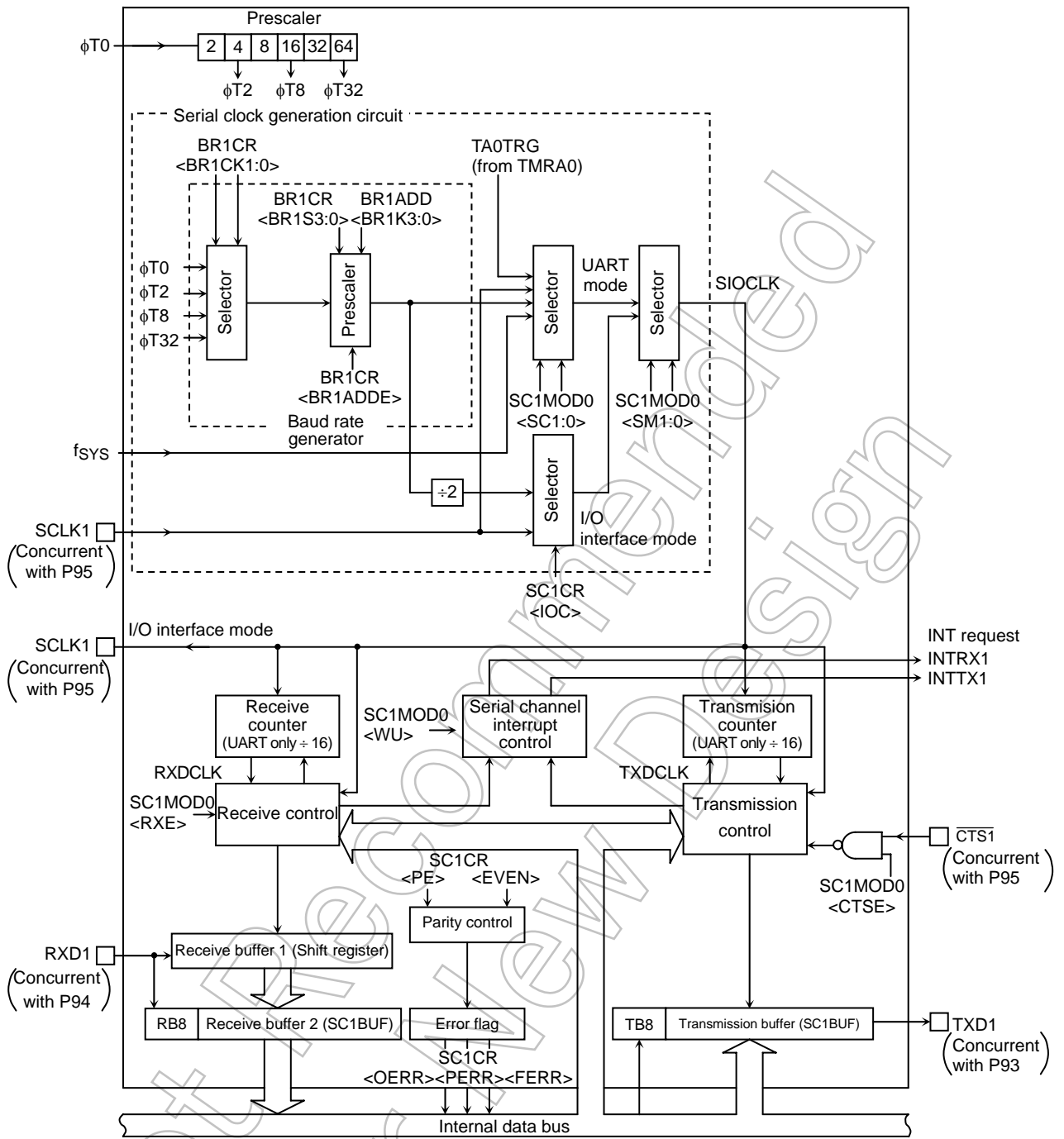

Figure 3.9.3 Block Diagram of the Serial Channel 1 (SIO1)

3.9.2 Operation of Each Circuit

(1) Prescaler

There is a 6-bit prescaler for generating a clock to SIO0. The clock selected using SYSCR<PRCK1:0> is divided by 4 and input to the prescaler as $\phi T0$. The prescaler can be run by selecting the baud rate generator as the serial transfer clock.

Table 3.9.2 shows prescaler clock resolution into the baud rate generator.

Table 3.9.2 Prescaler Clock Resolution to Baud Rate Generator

Select System Clock SYSCR1 <SYSCK>	Select Prescaler Clock SYSCR0 <PRCK1:0>	Gear Value SYSCR1<GEAR2:0>	Prescaler Output Clock Resolution			
			$\phi T0$	$\phi T2$	$\phi T8$	$\phi T32$
1 (fs)		XXX	$2^2/fs$	$2^4/fs$	$2^6/fs$	$2^8/fs$
0 (fc)	00 (fFPH)	000 (fc)	$2^2/fc$	$2^4/fc$	$2^6/fc$	$2^8/fc$
		001 (fc/2)	$2^3/fc$	$2^5/fc$	$2^7/fc$	$2^9/fc$
		010 (fc/4)	$2^4/fc$	$2^6/fc$	$2^8/fc$	$2^{10}/fc$
		011 (fc/8)	$2^5/fc$	$2^7/fc$	$2^9/fc$	$2^{11}/fc$
		100 (fc/16)	$2^6/fc$	$2^8/fc$	$2^{10}/fc$	$2^{12}/fc$
	10 (fc/16 clock)	XXX	-	$2^8/fc$	$2^{10}/fc$	$2^{12}/fc$

X: Don't care, -: Cannot be used

The baud rate generator selects between 4-clock inputs: $\phi T0$, $\phi T2$, $\phi T8$, and $\phi T32$ among the prescaler outputs.

(2) Baud rate generator

The baud rate generator is the circuit which generates transmission and receiving clocks which determine the transfer rate of the serial channels.

The input clock to the baud rate generator, $\phi T0$, $\phi T2$, $\phi T8$ or $\phi T32$, is generated by the 6-bit prescaler which is shared by the timers. One of these input clocks is selected using the BR0CR<BR0CK1:0> field in the baud rate generator control register.

The baud rate generator includes a frequency divider, which divides the frequency by 1 or $N + (16 - K)/16$ to 16 values, determining the transfer rate.

The transfer rate is determined by the settings of BR0CR<BR0ADDE, BR0S3:0> and BR0ADD<BR0K3:0>.

- In UART mode

- (1) When BR0CR<BR0ADDE> = 0

The settings BR0ADD<BR0K3:0> are ignored. The baud rate generator divides the selected prescaler clock by N, which is set in BR0CK<BR0S3:0>. (N = 1, 2, 3 ... 16)

- (2) When BR0CR<BR0ADDE> = 1

The $N + (16 - K)/16$ division function is enabled. The baud rate generator divides the selected prescaler clock by $N + (16 - K)/16$ using the value of N set in BR0CR<BR0S3:0> (N = 2, 3 ... 15) and the value of K set in BR0ADD<BR0K3:0> (K = 1, 2, 3 ... 15)

Note: If N = 1 or N = 16, the $N + (16 - K)/16$ division function is disabled. Set BR0CR<BR0ADDE> to 0.

- In I/O interface mode

The $N + (16 - K)/16$ division function is not available in I/O interface mode. Set BR0CR<BR0ADDE> to 0 before dividing by N.

The method for calculating the transfer rate when the baud rate generator is used is explained below.

- In UART mode

$$\text{Baud rate} = \frac{\text{Input clock of baud rate generator}}{\text{Frequency divider for baud rate generator}} \div 16$$

- In I/O interface mode

$$\text{Baud rate} = \frac{\text{Input clock of baud rate generator}}{\text{Frequency divider for baud rate generator}} \div 2$$

- Integer divider (N divider)

For example, when the source clock frequency (f_c) = 12.288 MHz, the input clock frequency = $\phi T2$ ($f_c/16$), the frequency divider N (BR0CR<BR0S3:0>) = 5, and BR0CR<BR0ADDE> = 0, the baud rate in UART mode is as follows:

* Clock state

System clock:	High frequency (f_c)
Clock gear:	1 (f_c)
Prescaler clock:	System clock

$$\begin{aligned} \text{Baud rate} &= \frac{f_c/16}{5} \div 16 \\ &= 12.288 \times 10^6 \div 16 \div 5 \div 16 = 9600 \text{ (bps)} \end{aligned}$$

Note: The $N + (16 - K)/16$ division function is disabled and setting BR0ADD<BR0K3:0> is invalid.

- $N + (16 - K)/16$ divider (UART mode only)

Accordingly, when the source clock frequency (f_c) = 4.8 MHz, the input clock frequency = $\phi T0$, the frequency divider N (BR0CR<BR0S3:0>) = 7, K (BR0ADD<BR0K3:0>) = 3, and BR0CR <BR0ADDE> = 1, the baud rate in UART mode is as follows:

* Clock state

System clock:	High frequency (f_c)
Clock gear:	1 (f_c)
Prescaler clock:	System clock

$$\begin{aligned} \text{Baud rate} &= \frac{f_c/4}{7 + \frac{(16-3)}{16}} \div 16 \\ &= 4.8 \times 10^6 \div 4 \div (7 + 13/16) \div 16 = 9600 \text{ (bps)} \end{aligned}$$

Table 3.9.3 show examples of UART mode transfer rates.

Additionally, the external clock input is available in the serial clock (Serial channels 0, 1). The method for calculating the baud rate is explained below:

- In UART mode

Baud rate = External clock input frequency \div 16

It is necessary to satisfy (External clock input cycle) \geq 4/ f_c

- In I/O interface mode

Baud rate = External clock input frequency

It is necessary to satisfy (External clock input cycle) \geq 16/ f_c

Table 3.9.3 Transfer Rate Selection

(when baud rate generator is used and BR0CR<BR0ADDE> = 0)

Unit (kbps)

fc [MHz]	Input Clock				
	Frequency Divider (set to BR1CR<BR1S3:0>)	$\phi T0$	$\phi T2$	$\phi T8$	$\phi T32$
9.830400	2	76.800	19.200	4.800	1.200
↑	4	38.400	9.600	2.400	0.600
↑	8	19.200	4.800	1.200	0.300
↑	0	9.600	2.400	0.600	0.150
12.288000	5	38.400	9.600	2.400	0.600
↑	A	19.200	4.800	1.200	0.300
14.745600	2	115.200	28.800	7.200	1.800
↑	3	76.800	19.200	4.800	1.200
↑	6	38.400	9.600	2.400	0.600
↑	C	19.200	4.800	1.200	0.300
19.6608	1	307.200	76.800	19.200	4.800
↑	2	153.600	38.400	9.600	2.400
↑	4	76.800	19.200	4.800	1.200
↑	8	38.400	9.600	2.400	0.600
↑	10	19.200	4.800	1.200	0.300
22.1184	3	115.200	28.800	7.200	1.800
24.576	1	384.000	96.000	24.000	6.000
↑	2	192.000	48.000	12.000	3.000
↑	4	96.000	24.000	6.000	1.500
↑	5	76.800	19.200	4.800	1.200
↑	8	48.000	12.000	3.000	0.750
↑	A	38.400	9.600	2.400	0.600
↑	10	24.000	6.000	1.500	0.375
27.0336	B	38.400	9.600	2.400	0.600

Note 1: Transfer rates in I/O interface mode are eight times faster than the values given above.

Note 2: The values in this table are calculated for when fc is selected as the system clock, the clock gear is set for fc/1 and the system clock is the prescaler clock input f_{PPH}.

Timer out clock (TA0TRG) can be used for source clock of UART mode only.

Calculation method the frequency of TA0TRG

Frequency of TA0TRG = Baud rate × 16

Note 1: The TMRA0 match detects signal cannot be used as the transfer clock in I/O interface mode.

(3) Serial clock generation circuit

This circuit generates the basic clock for transmitting and receiving data.

- In I/O interface mode

In SCLK output mode with the setting SC0CR<IOC> = 0, the basic clock is generated by dividing the output of the baud rate generator by 2, as described previously.

In SCLK input mode with the setting SC0CR<IOC> = 1, the rising edge or falling edge will be detected according to the setting of the SC0CR<SCLKS> register to generate the basic clock.

- In UART mode

The SC0MOD0<SC1:0> setting determines whether the baud rate generator clock, the internal system clock f_{sys}, the match detect signal from timer TMRA0 or the external clock (SCLK0) is used to generate the basic clock SIOCLK.

(4) Receiving counter

The receiving counter is a 4-bit binary counter used in UART mode which counts up the pulses of the SIOCLK clock. It takes 16 SIOCLK pulses to receive 1 bit of data; each data bit is sampled three times – on the 7th, 8th and 9th clock cycles.

The value of the data bit is determined from these three samples using the majority rule.

For example, if the data bit is sampled respectively as 1, 0 and 1 on 7th, 8th and 9th clock cycles, the received data bit is taken to be 1. A data bit sampled as 0, 0 and 1 is taken to be 0.

(5) Receiving control

- In I/O interface mode

In SCLK output mode with the setting SC0CR<IOC> = 0, the RXD0 signal is sampled on the rising edge or falling edge of the shift clock which is output on the SCLK0 pin, according to the SC0CR<SCLKS> setting.

In SCLK input mode with the setting SC0CR<IOC> = 1, the RXD0 signal is sampled on the rising or falling edge of the SCLK0 input, according to the SC0CR<SCLKS> setting.

- In UART mode

The receiving control block has circuit which detects a start bit using the majority rule. Received bits are sampled three times; when two or more out of three samples are 0, the bit is recognized as the start bit and the receiving operation commences.

The values of the data bits that are received are also determined using the majority rule.

(6) The receiving buffers

To prevent overrun errors, the receiving buffers are arranged in a double-buffer structure.

Received data is stored one bit at a time in receiving buffer 1 (which is a shift register). When 7 or 8 bits of data have been stored in receiving buffer 1, the stored data is transferred to receiving buffer 2 (SC0BUF); this causes an INTRX0 interrupt to be generated. The CPU only reads receiving buffer 2 (SC0BUF). Even before the CPU reads receiving buffer 2 (SC0BUF), the received data can be stored in receiving buffer 1. However, unless receiving buffer 2 (SC0BUF) is read before all bits of the next data are received by receiving buffer 1, an overrun error occurs. If an overrun error occurs, the contents of receiving buffer 1 will be lost, although the contents of receiving buffer 2 and SC0CR<RB8> will be preserved.

SC0CR<RB8> is used to store either the parity bit – added in 8-bit UART mode – or the most significant bit (MSB) – in 9-bit UART mode.

In 9-bit UART mode the wakeup function for the slave controller is enabled by setting SC0MOD0<WU> to 1; in this mode INTRX0 interrupts occur only when the value of SC0CR<RB8> is 1.

(7) Transmission counter

The transmission counter is a 4-bit binary counter which is used in UART mode and which, like the receiving counter, counts the SIOCLK clock pulses; a TXDCLK pulse is generated every 16 SIOCLK clock pulses.

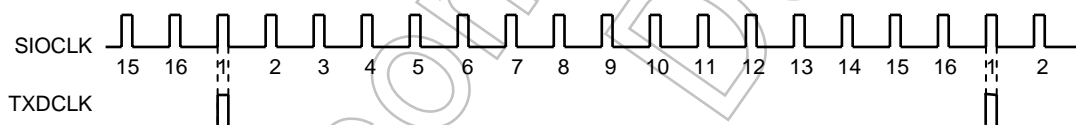

Figure 3.9.4 Generation of the Transmission Clock

(8) Transmission controller

- In I/O interface mode

In SCLK output mode with the setting SC0CR<IOC> = 0, the data in the transmission buffer is output one bit at a time to the TXD0 pin on the rising edge or falling edge of the shift clock which is output on the SCLK0 pin according to the SC0CR<SCLKS> setting.

In SCLK input mode with the setting SC0CR<IOC> = 1, the data in the transmission buffer is output one bit at a time on the TXD0 pin on the rising or falling edge of the SCLK0 input, according to the SC0CR<SCLKS> setting.

- In UART mode

When transmission data sent from the CPU is written to the transmission buffer, transmission starts on the rising edge of the next TXDCLK.

Handshake function

Use of \overline{CTS} pin allows data can be sent in units of one frame; thus, overrun errors can be avoided. The handshake functions is enabled or disabled by the SC0MOD<CTSE> setting.

When the $\overline{CTS0}$ pin goes high on completion of the current data send, data transmission is halted until the $\overline{CTS0}$ pin goes low again. However, the INTTX0 interrupt is generated, it requests the next data send to the CPU. The next data is written in the transmission buffer and data sending is halted.

Though there is no RTS pin, a handshake function can be easily configured by setting any port assigned to be the \overline{RTS} function. The \overline{RTS} should be output high to request send data halt after data receive is completed by software in the \overline{RXD} interrupt routine.

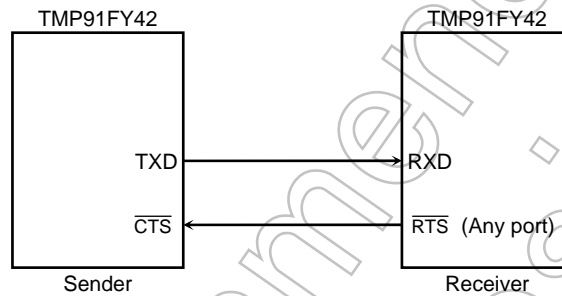
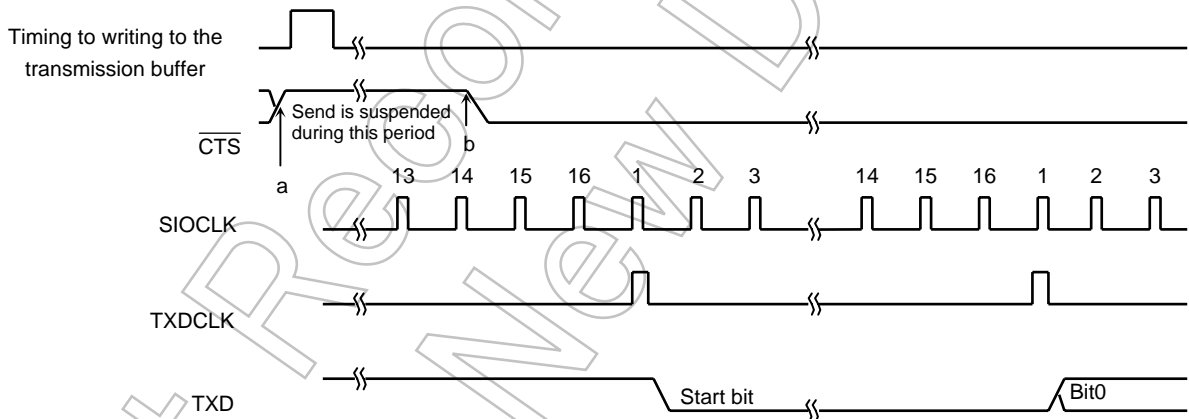

Figure 3.9.5 Handshake Function



Note 1: If the \overline{CTS} signal goes high during transmission, no more data will be sent after completion of the current transmission.

Note 2: Transmission starts on the first falling edge of the TXDCLK clock after the \overline{CTS} signal has fallen.

Figure 3.9.6 \overline{CTS} (Clear to send) Timing

(9) Transmission buffer

The transmission buffer (SC0BUF) shifts out and sends the transmission data written from the CPU from the least significant bit (LSB) in order. When all the bits are shifted out, the transmission buffer becomes empty and generates an INTTX0 interrupt.

(10) Parity control circuit

When SC0CR<PE> in the serial channel control register is set to 1, it is possible to transmit and receive data with parity. However, parity can be added only in 7-bit UART mode or 8-bit UART mode. The SC0CR<EVEN> field in the serial channel control register allows either even or odd parity to be selected.

In the case of transmission, parity is automatically generated when data is written to the transmission buffer SC0BUF. The data is transmitted after the parity bit has been stored in SC0BUF<TB7> in 7-bit UART mode or in SC0MOD0<TB8> in 8-bit UART mode. SC0CR<PE> and SC0CR<EVEN> must be set before the transmission data is written to the transmission buffer.

In the case of receiving, data is shifted into receiving buffer 1, and the parity is added after the data has been transferred to receiving buffer 2 (SC0BUF), and then compared with SC0BUF<RB7> in 7-bit UART mode or with SC0CR<RB8> in 8-bit UART mode. If they are not equal, a parity error is generated and the SC0CR<PERR> flag is set.

(11) Error flags

Three error flags are provided to increase the reliability of data reception.

1. Overrun error <OERR>

If all the bits of the next data item have been received in receiving buffer 1 while valid data still remains stored in receiving buffer 2 (SC0BUF), an overrun error is generated.

The below is a recommended flow when the overrun error is generated.

(INTRX interrupt routine)

1) Read receiving buffer

2) Read error flag

3) If <OERR> = 1

then

a) Set to disable receiving (Write 0 to SC0MOD0<RXE>)

b) Wait to terminate current frame

c) Read receiving buffer

d) Read error flag

e) Set to enable receiving (Write 1 to SC0MOD0<RXE>)

f) Request to transmit again

4) Other

2. Parity error <PERR>

The parity generated for the data shifted into receiving buffer 2 (SC0BUF) is compared with the parity bit received via the RXD pin. If they are not equal, a parity error is generated.

3. Framing error <FERR>

The stop bit for the received data is sampled three times around the center. If the majority of the samples are 0, a Framing error is generated.

(12) Timing generation

a. In UART mode

Receiving

Mode	9 Bits (Note)	8 Bits + Parity (Note)	8 Bits, 7 Bits + Parity, 7 Bits
Interrupt timing	Center of last bit (Bit8)	Center of last bit (Parity bit)	Center of stop bit
Framing error timing	Center of stop bit	Center of stop bit	Center of stop bit
Parity error timing	-	Center of last bit (Parity bit)	Center of stop bit
Overrun error timing	Center of last bit (Bit8)	Center of last bit (Parity bit)	Center of stop bit

Note: In 9-Bit and 8-Bit+Parity mode, interrupts coincide with the ninth bit pulse. Thus, when servicing the interrupt, it is necessary to wait for a 1-bit period (to allow the stop bit to be transferred) to allow checking for a framing error.

Transmitting

Mode	9 Bits	8 Bits + Parity	8 Bits, 7 Bits + Parity, 7 Bits
Interrupt timing	Just before stop bit is transmitted	Just before stop bit is transmitted	Just before stop bit is transmitted

b. I/O interface

Transmission interrupt timing	SCLK output mode	Immediately after the last bit. (See Figure 3.9.19.)
	SCLK input mode	Immediately after rise of last SCLK signal rising mode, or immediately after fall in falling mode. (See Figure 3.9.20.)
Receiving interrupt timing	SCLK output mode	Timing used to transfer received to data receive buffer 2 (SC0BUF) (e.g., immediately after last SCLK). (See Figure 3.9.21.)
	SCLK input mode	Timing used to transfer received data to receive buffer 2 (SC0BUF) (e.g., immediately after last SCLK). (See Figure 3.9.22.)

3.9.3 SFRs

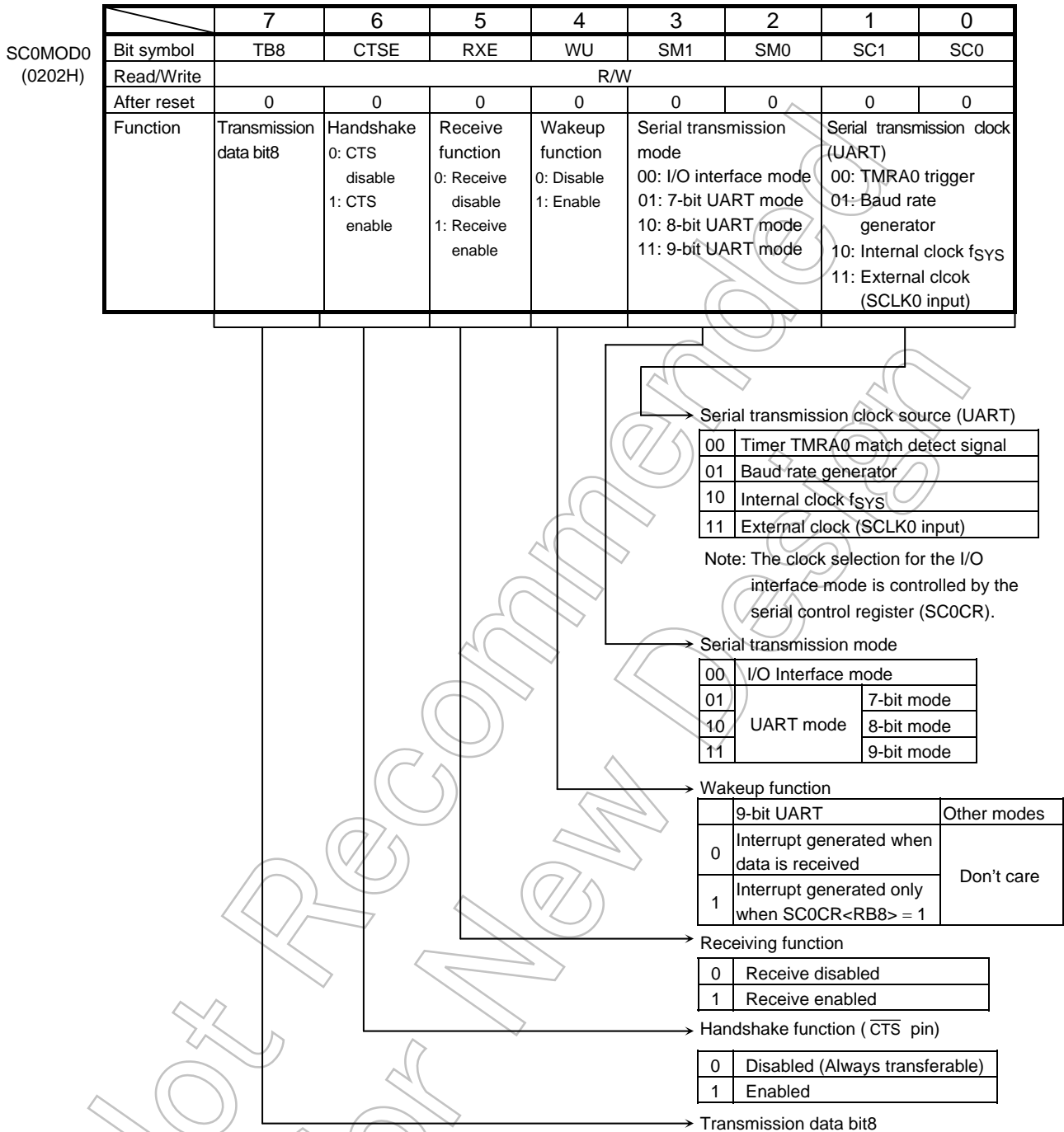

Figure 3.9.7 Serial Mode Control Register (SIO0, SC0MOD0)

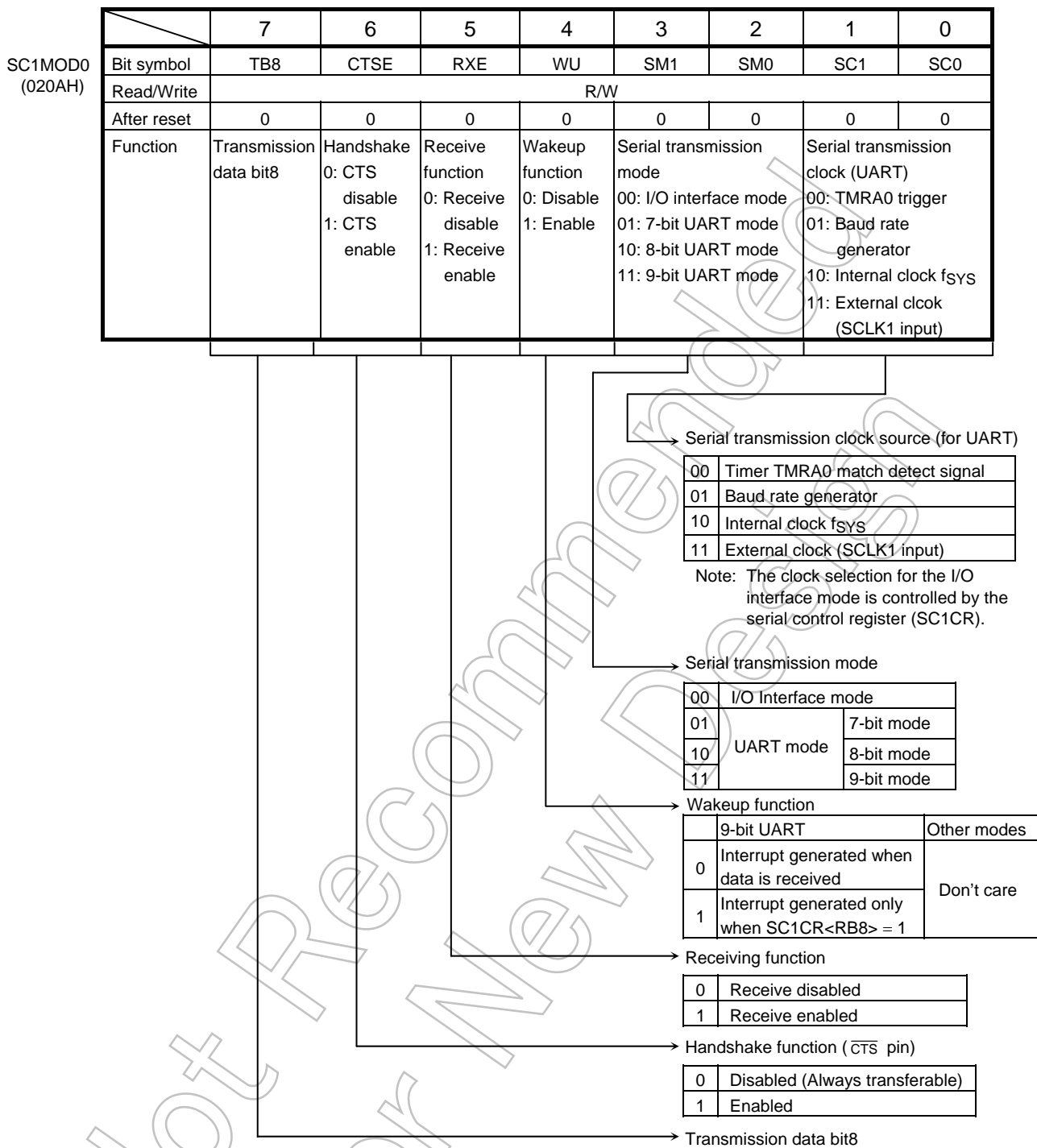
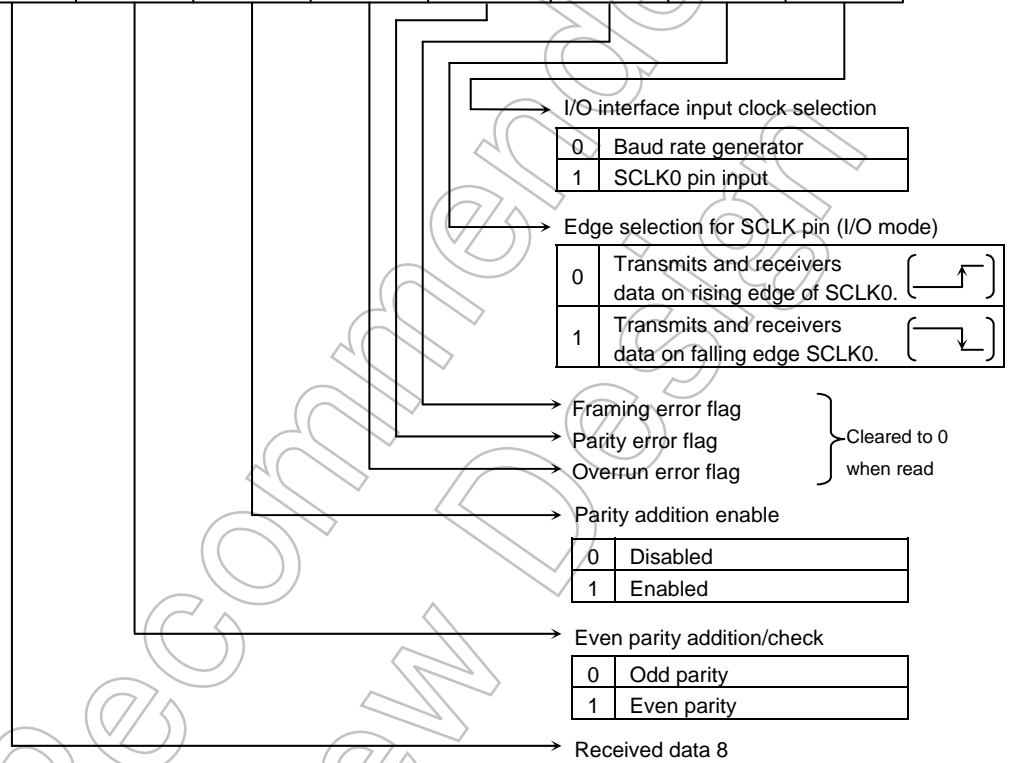

Figure 3.9.8 Serial Mode Control Register (SIO1, SC1MOD0)

SC0CR
(0201H)

	7	6	5	4	3	2	1	0
Bit symbol	RB8	EVEN	PE	OERR	PERR	FERR	SCLKS	IOC
Read/Write	R	R/W		R (Cleared to 0 when read)			R/W	
After reset	Undefined	0	0	0	0	0	0	0
Function	Received data bit8	Parity 0: Odd 1: Even	Parity addition 0: Disable 1: Enable	1: Error			0: SCLK0	0: Baud rate generator 1: SCLK0 pin input
				Overrun	Parity	Framing	1: SCLK0	



Note: As all error flags are cleared after reading do not test only a single bit with a bit-testing instruction.

Figure 3.9.9 Serial Control Register (SIO0, SC0CR)

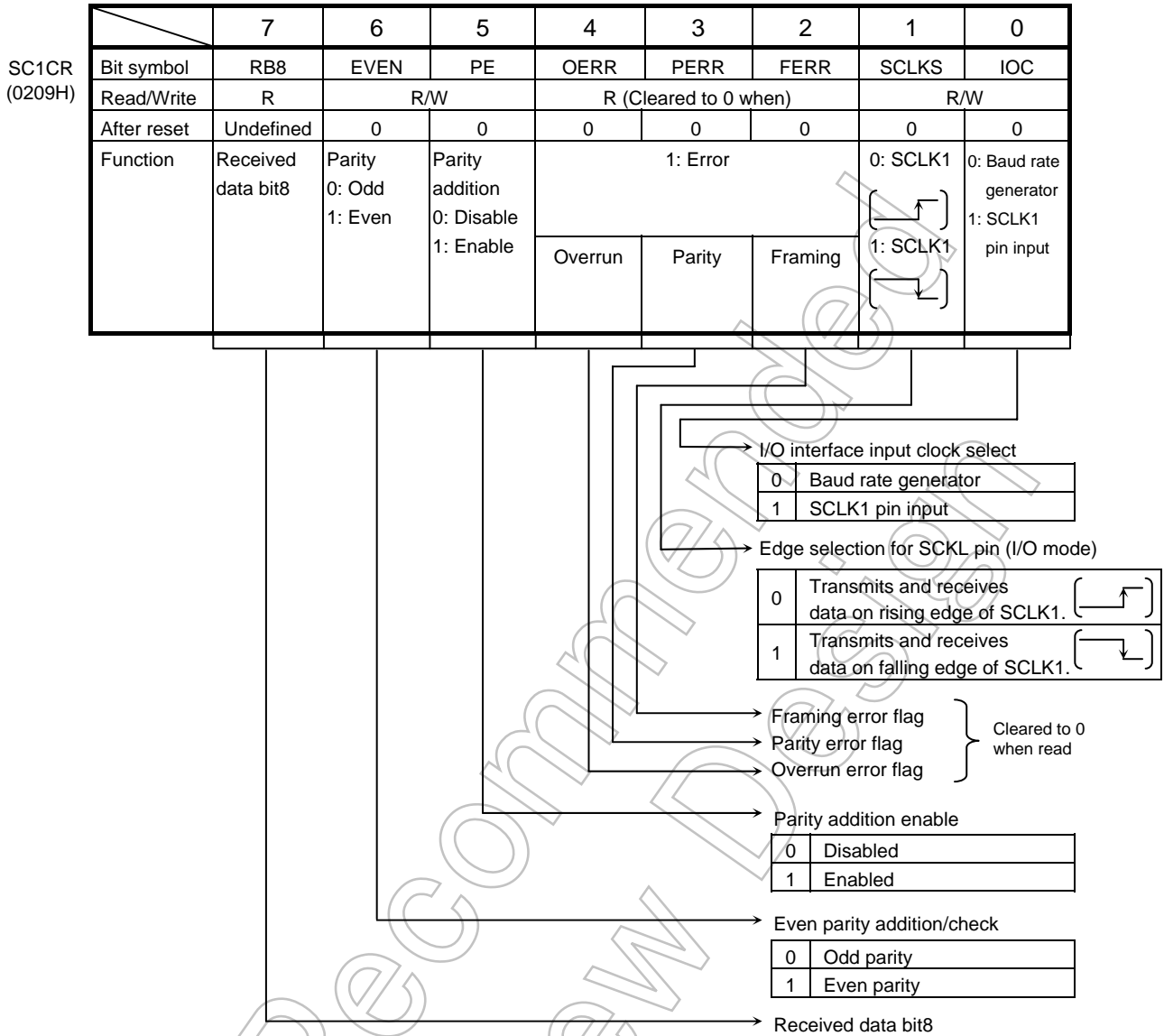

Note: As all error flags are cleared after reading do not test only a single bit with a bit-testing instruction.

Figure 3.9.10 Serial Control Register (SIO1, SC1CR)

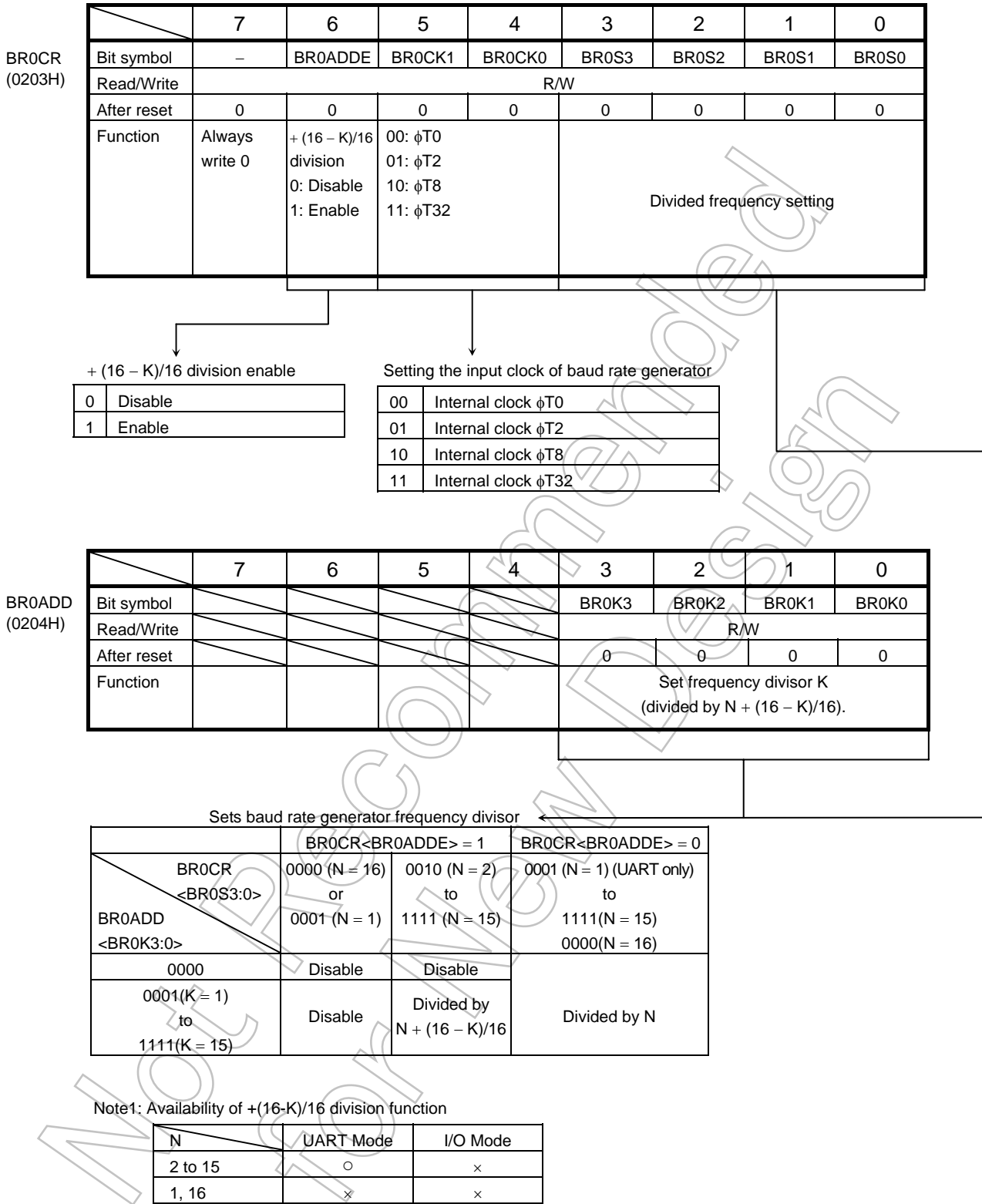

The baud rate generator can be set to "1" in UART mode only when the +(16-K)/16 division function is not used. Do not use in I/O interface mode.

Note2: Set BR0CR <BR0ADDE> to 1 after setting K (K = 1 to 15) to BR0ADD<BR0K3:0> when +(16-K)/16 division function is used. Writes to unused bits in the BR0ADD register do not affect operation, and undefined data is read from these unused bits.

Figure 3.9.11 Baud Rate Generator Control (SIO0, BR0CR, BR0ADD)

	7	6	5	4	3	2	1	0
Bit symbol	-	BR1ADDE	BR1CK1	BR1CK0	BR1S3	BR1S2	BR1S1	BR1S0
Read/Write	R/W							
After reset	0	0	0	0	0	0	0	0
Function	Always write 0	+ (16 - K)/16 division 0: Disable 1: Enable	00: φT0 01: φT2 10: φT8 11: φT32		Divided frequency setting			

+ (16 - K)/16 division enable

0	Disabled
1	Enabled

Input clock selection for baud rate generator

00	Internal clock φT0
01	Internal clock φT2
10	Internal clock φT8
11	Internal clock φT32

	7	6	5	4	3	2	1	0
Bit symbol					BR1K3	BR1K2	BR1K1	BR1K0
Read/Write					R/W			
After reset					0	0	0	0
Function					Set frequency divisor K (divided by N + (16 - K)/16).			

Baud rate generator frequency divisor setting

	BR1CR<BR1ADDE> = 1	BR1CR<BR1ADDE> = 0
BR1CR <BR1S3:0>	0000 (N = 16) or 0001 (N = 1)	0010 (N = 2) to 1111 (N = 15)
BR1ADD <BR1K3:0>	0000	0001 (N = 1) (UART only) to 1111 (N = 15) 0000 (N = 16)
0000	Disable	Disable
0001 (K = 1) to 1111 (K = 15)	Disable	Disabled by N + (16 - K)/16
		Divided by N

Note1: Availability of +(16-K)/16 division function

N	UART Mode	I/O Mode
2 to 15	○	×
1, 16	×	×

The baud rate generator can be set "1" in UART mode only when the +(16-K)/16 division function is not used. Do not use in I/O interface mode.

Note2: Set BR1CR <BR1ADDE> to 1 after setting K (K = 1 to 15) to BR1ADD<BR1K3:0> when +(16-K)/16 division function is used. Writes to unused bits in the BR1ADD register do not affect operation, and undefined data is read from these unused bits.

Figure 3.9.12 Baud Rate Generator Control (SIO1, BR1CR, BR1ADD)

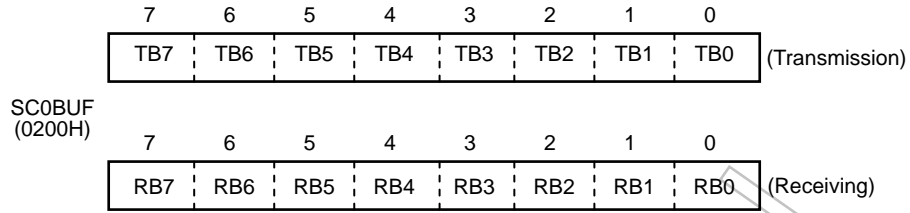

Note: Prohibit read modify write for SC0BUF.

Figure 3.9.13 Serial Transmission/Receiving Buffer Registers (SIO0, SC0BUF)

	7	6	5	4	3	2	1	0
SC0MOD1 (0205H)	Bit symbol		I2S0	FDPX0				
	Read/Write		R/W					
	After reset		0	0				
	Function		IDLE2 0: Stop 1: Run	Duplex 0: Half 1: Full				

Figure 3.9.14 Serial Mode Control Register 1 (SIO0, SC0MOD1)

Not Recommended for New Designs

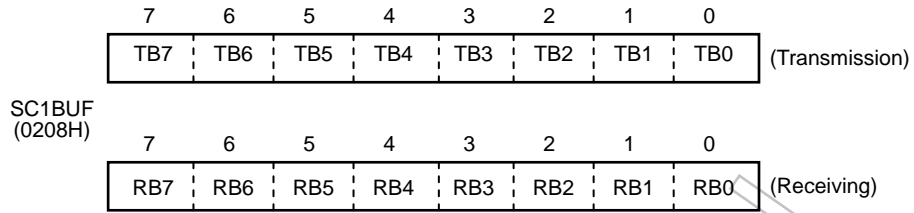

Note: Prohibit read modify write for SC1BUF.

Figure 3.9.15 Serial Transmission/Receiving Buffer Registers (SIO1, SC1BUF)

	7	6	5	4	3	2	1	0
SC1MOD1 (020DH)	Bit symbol		I2S1	FDPX1				
	Read/Write		R/W					
	After reset		0	0				
	Function		IDLE2 0: Stop 1: Run	Duplex 0: Half 1: Full				

Figure 3.9.16 Serial Mode Control Register 1 (SIO1, SC1MOD1)

Not Recommended for New Designs

3.9.4 Operation in Each Mode

(1) Mode 0 (I/O interface mode)

This mode allows an increase in the number of I/O pins available for transmitting data to or receiving data from an external shift register.

This mode includes the SCLK output mode to output synchronous clock SCLK and SCLK input mode to input external synchronous clock SCLK.

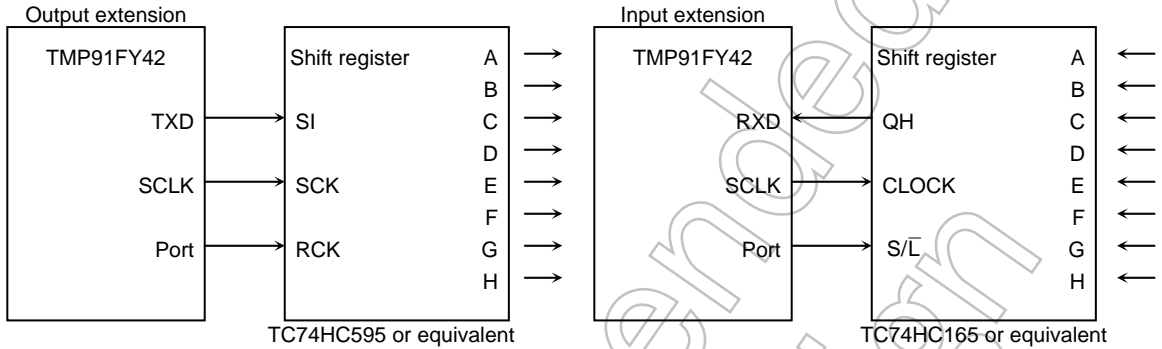

Figure 3.9.17 SCLK Output Mode Connection Example

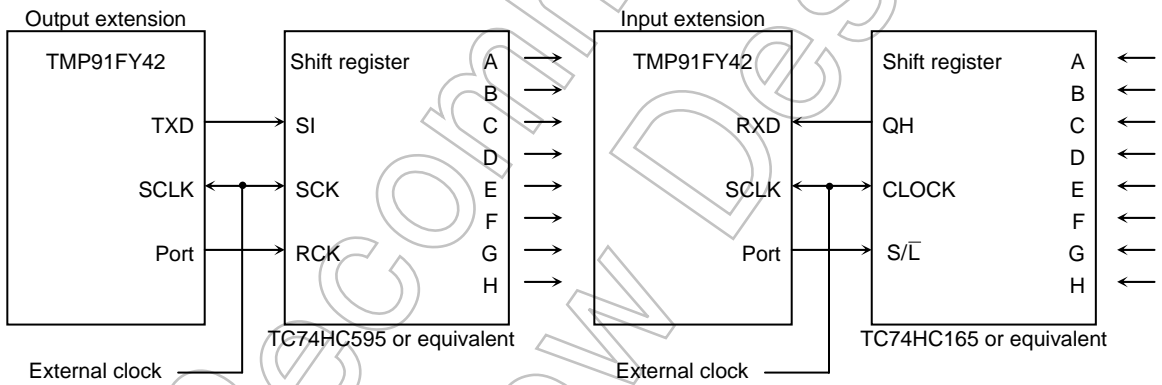

Figure 3.9.18 SCLK Input Mode Connection Example

a. Transmission

In SCLK output mode 8-bit data and a synchronous clock are output on the TXD0 and SCLK0 pins respectively each time the CPU writes the data to the transmission buffer. When all data is output, INTES0<ITX0C> will be set to generate the INTTX0 interrupt.

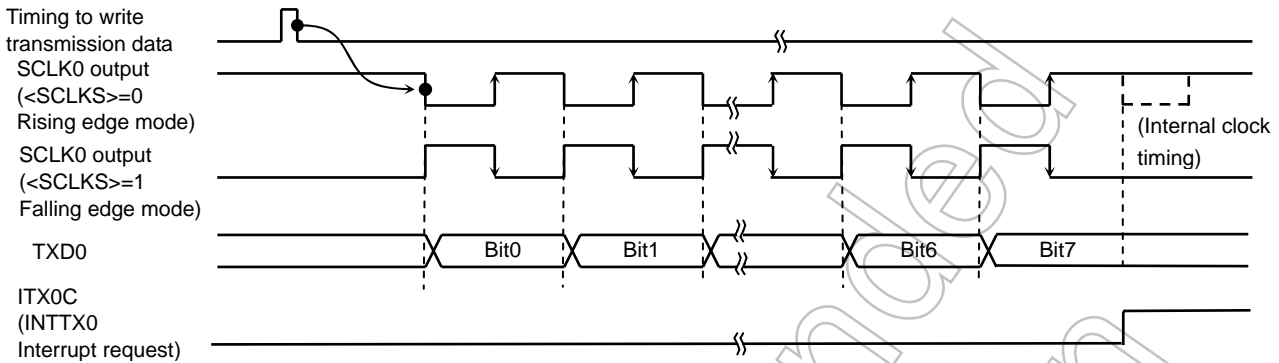

Figure 3.9.19 Transmitting Operation in I/O Interface Mode (SCLK0 output mode)

In SCLK input mode, 8-bit data is output on the TXD0 pin when the SCLK0 input becomes active after the data has been written to the transmission buffer by the CPU.

When all data is output, INTES0<ITX0C> will be set to generate INTTX0 interrupt.

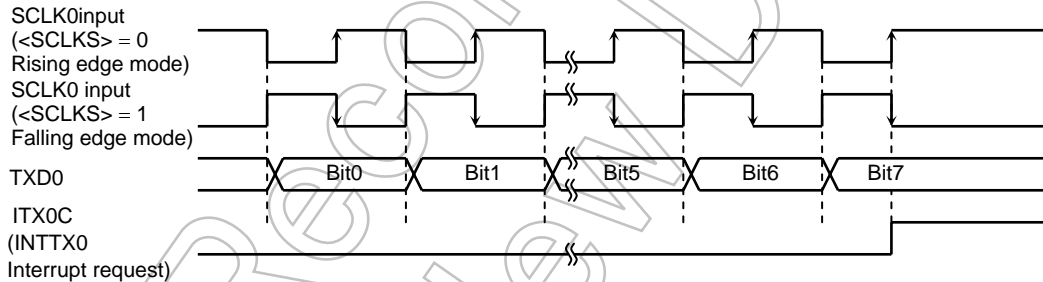

Figure 3.9.20 Transmitting Operation in I/O Interface Mode (SCLK0 input mode)

b. Receiving

In SCLK output mode, the synchronous clock is outputted from SCLK0 pin and the data is shifted to receiving buffer 1. This starts when the receive interrupt flag INTES0<IRX0C> is cleared by reading the received data. When 8-bit data are received, the data will be transferred to receiving buffer 2 (SC0BUF according to the timing shown below) and INTES0<IRX0C> will be set to generate INTRX0 interrupt.

The outputting for the first SCLK0 starts by setting SC0MOD0<RXE> to 1.

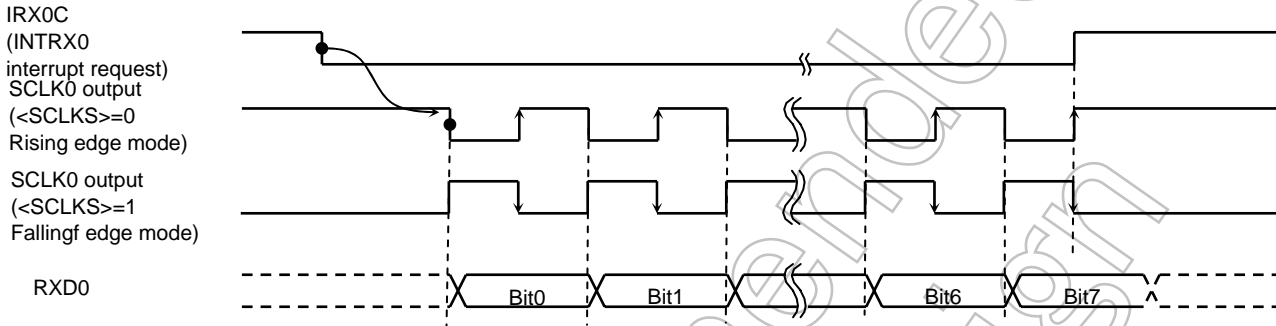

Figure 3.9.21 Receiving Operation in I/O Interface Mode (SCLK0 output mode)

In SCLK input mode, the data is shifted to receiving buffer 1 when the SCLK input becomes active after the receive interrupt flag INTES0<IRX0C> is cleared by reading the received data. When 8-bit data is received, the data will be shifted to receiving buffer 2 (SC0BUF according to the timing shown below) and INTES0<IRX0C> will be set again to be generate INTRX0 interrupt.

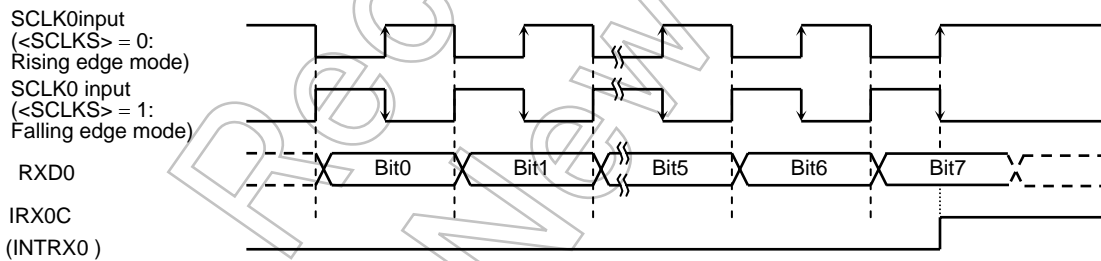

Figure 3.9.22 Receiving Operation in I/O Interface Mode (SCLK0 input mode)

Note: The system must be put in the receive enable state (SCMOD0<RXE> = 1) before data can be received.

c. Transmission and receiving (Full duplex mode)

When the full duplex mode is used, set the level of Receive Interrupt to 0 and set enable the interrupt level (1 to 6) to the transfer interrupt. In the transfer interrupt program, The receiving operation should be done like the above example before setting the next transfer data.

Example: Channel 0, SCLK output

Baud rate = 9600 bps

fc = 14.7456 MHz

* Clock state

System clock: High frequency (fc)
 Clock gear: 1 (fc)
 Prescaler clock: f_{PPH}

Main routine

	7	6	5	4	3	2	1	0
INTES0	-	0	0	1	-	0	0	0
P9CR	-	-	-	-	-	1	0	1

Set the INTTX0 level to 1.
 Set the INTRX0 level to 0.
 Set P90, P91 and P92 to function as the TXD0, RXD0 and SCLK0 pins respectively.

P9FC	X	X	-	X	-	1	X	1
SC0MOD0	-	-	-	-	0	0	-	-
SC0MOD1	1	1	X	X	X	X	X	X
SC0CR	-	-	-	-	-	-	0	-

Select I/O interface mode.
 Select full duplex mode.
 SCLK output, transmit on negative edge, receive on positive edge

BR0CR	0	0	1	1	0	0	1	1
SC0MOD0	-	-	1	-	-	-	-	-
SC0BUF	*	*	*	*	*	*	*	*

Baud rate = 9600 bps
 Enable receiving
 Set the transmit data and start.

INTTX0 interrupt routine

Acc SC0BUF								
SC0BUF	*	*	*	*	*	*	*	*

Read the receiving buffer.
 Set the next transmit data.

X: Don't care, -: No change

Not Recommended for New

(2) Mode 1 (7-bit UART mode)

7-bit UART mode is selected by setting serial channel mode register SC0MOD0<SM1:0> to 01.

In this mode, a parity bit can be added. Use of a parity bit is enabled or disabled by the setting of the serial channel control register SC0CR<PE> bit; whether even parity or odd parity will be used is determined by the SC0CR<EVEN> setting when SC0CR<PE> is set to 1 (Enabled).

Example: When transmitting data of the following format, the control registers should be set as described below. This explanation applies to channel 0.

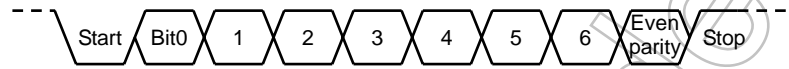

← Transmission direction (Transmission rate: 2400 bps at fc = 12.288 MHz)

* Clock state

System clock: High frequency (fc)
 Clock gear: 1 (fc)
 Prescaler clock: System clock

		7	6	5	4	3	2	1	0	
P9CR	←	X	X	-	-	-	-	-	1	} Set P90 to function as the TXD0 pin.
P9FC	←	X	X	-	X	-	-	X	1	
SC0MOD0	←	-	-	-	-	0	1	0	1	Select 7-bit UART mode.
SC0CR	←	-	1	1	-	-	-	-	-	Add even parity.
BR0CR	←	0	0	1	0	0	1	0	1	Set the transfer rate to 2400 bps.
INTES0	←	-	1	0	0	-	-	-	-	Enable the INTTX0 interrupt and set it to interrupt level 4.
SC0BUF	←	*	*	*	*	*	*	*	*	Set data for transmission.

X: Don't care, -: No change

(3) Mode 2 (8-bit UART mode)

8-bit UART mode is selected by setting SC0MOD0<SM1:0> to 10. In this mode, a parity bit can be added (use of a parity bit is enabled or disabled by the setting of SC0CR<PE>); whether even parity or odd parity will be used is determined by the SC0CR<EVEN> setting when SC0CR<PE> is set to 1 (Enabled).

Example: When receiving data of the following format, the control registers should be set as described below.

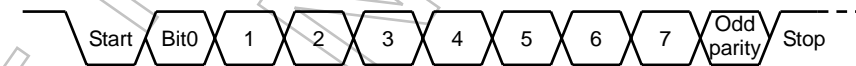

← Transmission direction (Transmission rate: 9600 bps at fc = 12.288 MHz)

* Clock state

System clock: High frequency (fc)
 Clock gear: 1 (fc)
 Prescaler clock: System clock

Main settings

7 6 5 4 3 2 1 0
 P9CR ← - - - - - 0 -
 SCOMOD0 ← - - 1 - 1 0 0 1
 SCOCR ← - 0 1 - - - - -
 BROCR ← 0 0 0 1 0 1 0 1
 INTES0 ← - - - - - 1 0 0

Set P91 to function as the RXD0 pin.
 Enable receiving in 8-bit UART mode.
 Add even parity.
 Set the transfer rate to 9600 bps.
 Enable the INTTX0 interrupt and set it to interrupt level 4.

Interrupt processing

Acc ← SCOCR AND 00011100 }
 if Acc ≠ 0 then ERROR }
 Acc ← SC0BUF

Check for errors.
 Read the received data.

X: Don't care, -: No change

(4) Mode 3 (9-bit UART mode)

9-bit UART mode is selected by setting SCOMOD0<SM1:0> to 11. In this mode parity bit cannot be added.

In the case of transmission the MSB (9th bit) is written to SCOMOD0<TB8>. In the case of receiving it is stored in SCOCR<RB8>. When the buffer is written and read, the MSB is read or written first, before the rest of the SC0BUF data.

Wakeup function

In 9-bit UART mode, the wakeup function for slave controllers is enabled by setting SCOMOD0<WU> to 1. The interrupt INTRX0 occurs only when <RB8> = 1.

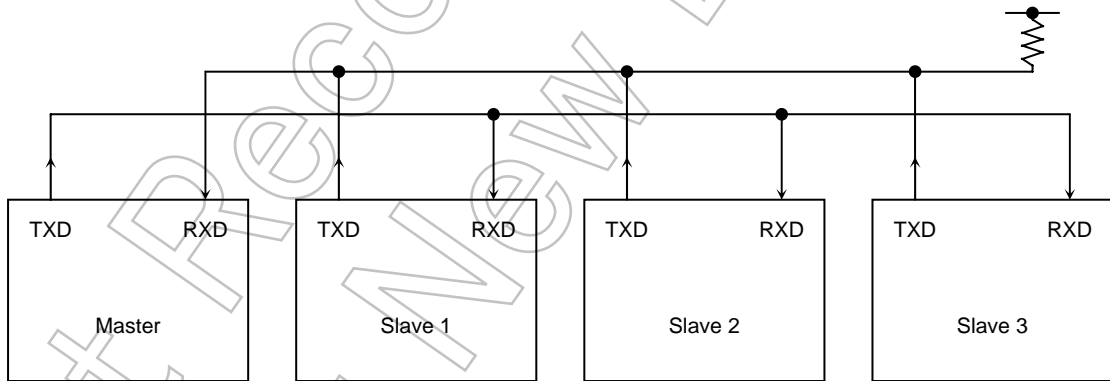

Note: The TXD pin of each slave controller must be in Open-drain output mode.

Figure 3.9.23 Serial Link Using Wakeup Function

Protocol

- (1) Select 9-bit UART mode on the master and slave controllers.
- (2) Set the SC0MOD0<WU> bit on each slave controller to 1 to enable data receiving.
- (3) The master controller transmits one-frame data including the 8-bit select code for the slave controllers. The MSB (Bit8) <TB8> is set to 1.

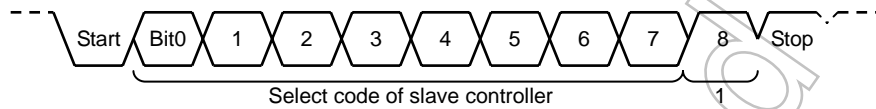

- (4) Each slave controller receives the above frame. Each controller checks the above select code against its own select code. The controller whose code matches clears its WU bit to 0.
- (5) The master controller transmits data to the specified slave controller whose SC0MOD<WU> bit is cleared to 0. The MSB (Bit8) <TB8> is cleared to 0.



- (6) The other slave controllers (whose <WU> bits remain at 1) ignore the received data because their MSBs (Bit8 or <RB8>) are set to 0, disabling INTRX0 interrupts.
The slave controller (WU bit = 0) can transmit data to the master controller, and it is possible to indicate the end of data receiving to the master controller by this transmission.

Example: To link two slave controllers serially with the master controller using the internal clock f_{SYS} as the transfer clock.

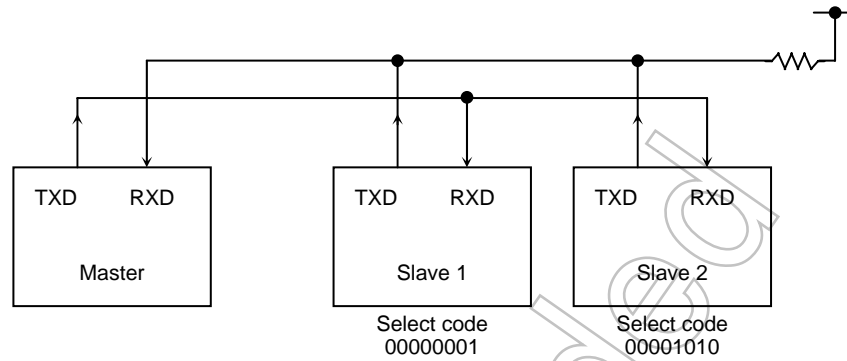

Since serial channels 0 and 1 operate in exactly the same way, channel 0 only is used for the purposes of this explanation.

- Setting the master controller

Main

P9CR	← - - - - - 0 1	} Set P90 and P91 to function as the TXD0 and RXD0 pins respectively.
P9FC	← X X - X - - X 1	
INTES0	← - 1 0 0 - 1 0 1	Enable the INTTX0 interrupt and set it to interrupt level 4.
		Enable the INTRX0 interrupt and set it to interrupt level 5.
SC0MOD0	← 1 - 1 - 1 1 1 0	Set f _{SYS} as the transmission clock for 9-bit UART mode.
SC0BUF	← 0 0 0 0 0 0 0 1	Set the select code for slave controller 1.

INTTX0 interrupt

SC0MOD0	← 0 - - - - -	Set TB8 to 0.
SC0BUF	← * * * * * * * *	Set data for transmission.

- Setting the slave controller

Main

P9CR	← - - - - - 0 1	} Set P91 to RXD0 and P90 to TXD0 (Open-drain output).
P9FC	← X X - X - - X 1	
ODE	← X X X X - X X 1	
INTES0	← - 1 0 1 - 1 1 0	Enable INTRX0 and INTTX0.
SC0MOD0	← - - 1 1 1 1 1 0	Set <WU> to 1 in 9-bit UART transmission mode using f _{SYS} as the transfer clock.

INTRX0 interrupt

Acc ← SC0BUF
 if Acc = select code
 Then SC0MOD0 ← - - - 0 - - - - Clear <WU> to 0.

3.9.5 Support for IrDA

SIO0 includes support for the IrDA 1.0 infrared data communication specification. Figure 3.9.24 shows the block diagram.

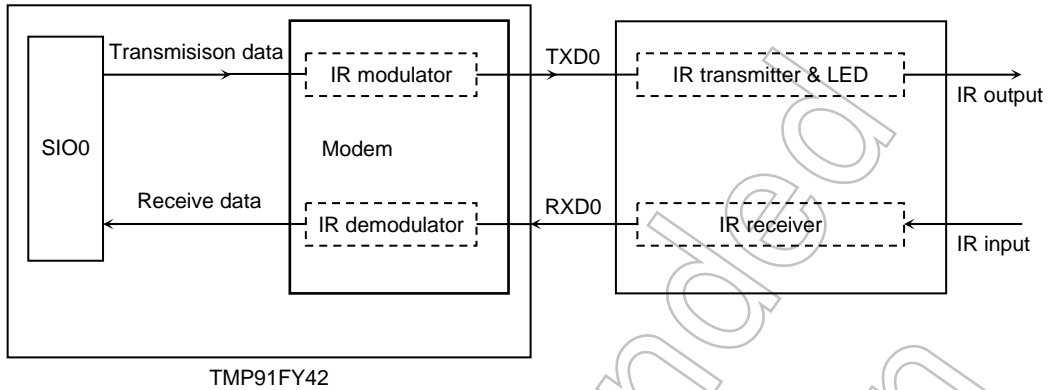

Figure 3.9.24 IrDA Block Diagram

(1) Modulation of the transmission data

When the transfer data is 0, the modem outputs 1 to TXD0 pin with either 3/16 or 1/16 times for width of baud rate. The pulse width is selected by the SIRCR<PLSEL>. When the transfer data is 1, the modem outputs 0.

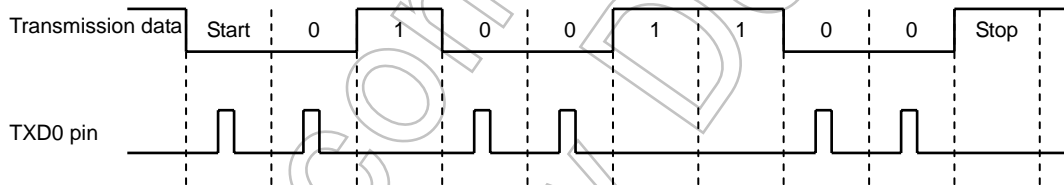

Figure 3.9.25 Modulation Example of Transfer Data

(2) Modulation of the receive data

When the receive data has the effective high level pulse width (Software selectable), the modem outputs 0 to SIO0. Otherwise the modem outputs 1 to SIO0. The receive pulse logic is also selectable by SIRCR<RXSEL>.

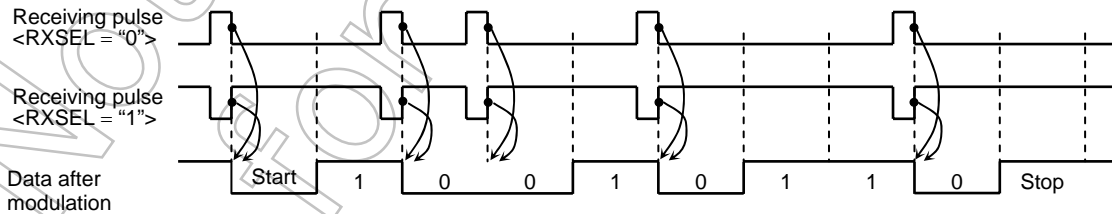

Figure 3.9.26 Demodulation Example of Receive Data

(3) Data format

The data format is fixed as follows:

- Data length: 8-bit
- Parity bits: none
- Stop bits: 1

Any other settings don't guarantee the normal operation.

(4) SFR

Figure 3.9.27 shows the control register SIRCR. Set the data SIRCR during SIO0 is inhibited (Both TXEN and RXEN of this register should be set to 0).

Any changing for this register during transmission or receiving operation don't guarantee the normal operation.

The following example describes how to set this register:

- 1) SIO setting ; Set the SIO to UART Mode.
↓
- 2) LD (SIRCR), 07H ; Set the receive data pulse width to 16×.
- 3) LD (SIRCR), 37H ; TXEN, RXEN Enable the Transmission and receiving of SIO.
↓
- 4) Start transmission and receiving for SIO0 ; The modem operates as follows:
 - SIO0 starts transmitting.
 - IR receiver starts receiving.

(5) Notes

1) Baud rate generator for IrDA

To generate baud rate for IrDA, use baud rate generator in SIO0 by setting 01 to SCOMOD0<SC1:0>. To use another source (TA0TRG, fSYS and SCLK0 input) are not allowed.

2) As the IrDA 1.0 physical layer specification, the data transfer speed and infra-red pulse width is specified.

Table 3.9.4 Baud Rate and Pulse Width Specifications

Baud Rate	Modulation	Rate Tolerance (% of rate)	Pulse Width (Minimum)	Pulse Width (Typical)	Pulse Width (Maximum)
2.4 kbps	RZI	±0.87	1.41 μs	78.13 μs	88.55 μs
9.6 kbps	RZI	±0.87	1.41 μs	19.53 μs	22.13 μs
19.2 kbps	RZI	±0.87	1.41 μs	9.77 μs	11.07 μs
38.4 kbps	RZI	±0.87	1.41 μs	4.88 μs	5.96 μs
57.6 kbps	RZI	±0.87	1.41 μs	3.26 μs	4.34 μs
115.2 kbps	RZI	±0.87	1.41 μs	1.63 μs	2.23 μs

The infra-red pulse width is specified either baud rate $T \times 3/16$ or 1.6 μs (1.6 μs is equal to 3/16 pulse width when baud rate is 115.2 kbps).

The TMP91FY42F has the function selects the pulse width on the transmission either 3/16 or 1/16. But 1/16 pulse width can be selected when the baud rate is equal or less than 38.4 kbps only. When 57.6 kbps and 115.2 kbps, the output pulse width should not be set to $T \times 1/16$.

As the same reason, $(16 - k)/16$ division function in the baud rate generator of SIO0 can not be used to generate 115.2 kbps baud rate.

Also when the 38.4 kbps and $1/16$ pulse width, $(16 - k)/16$ division function can not be used. Table 3.9.5 shows Baud rate and pulse width for $(16 - k)/16$ division function.

Table 3.9.5 Baud Rate and Pulse Width for $(16 - k)/16$ Division Function

Pulse Width	Baud Rate					
	115.2 kbps	57.6 kbps	38.4 kbps	19.2 kbps	9.6 kbps	2.4 kbps
$T \times 3/16$	×	○	○	○	○	○
$T \times 1/16$	–	–	×	○	○	○

- : Can be used $(16 - k)/16$ division function
- ×: Can not be used $(16 - k)/16$ division function
- : Can not be set to $1/16$ pulse width

Not Recommended for New Design

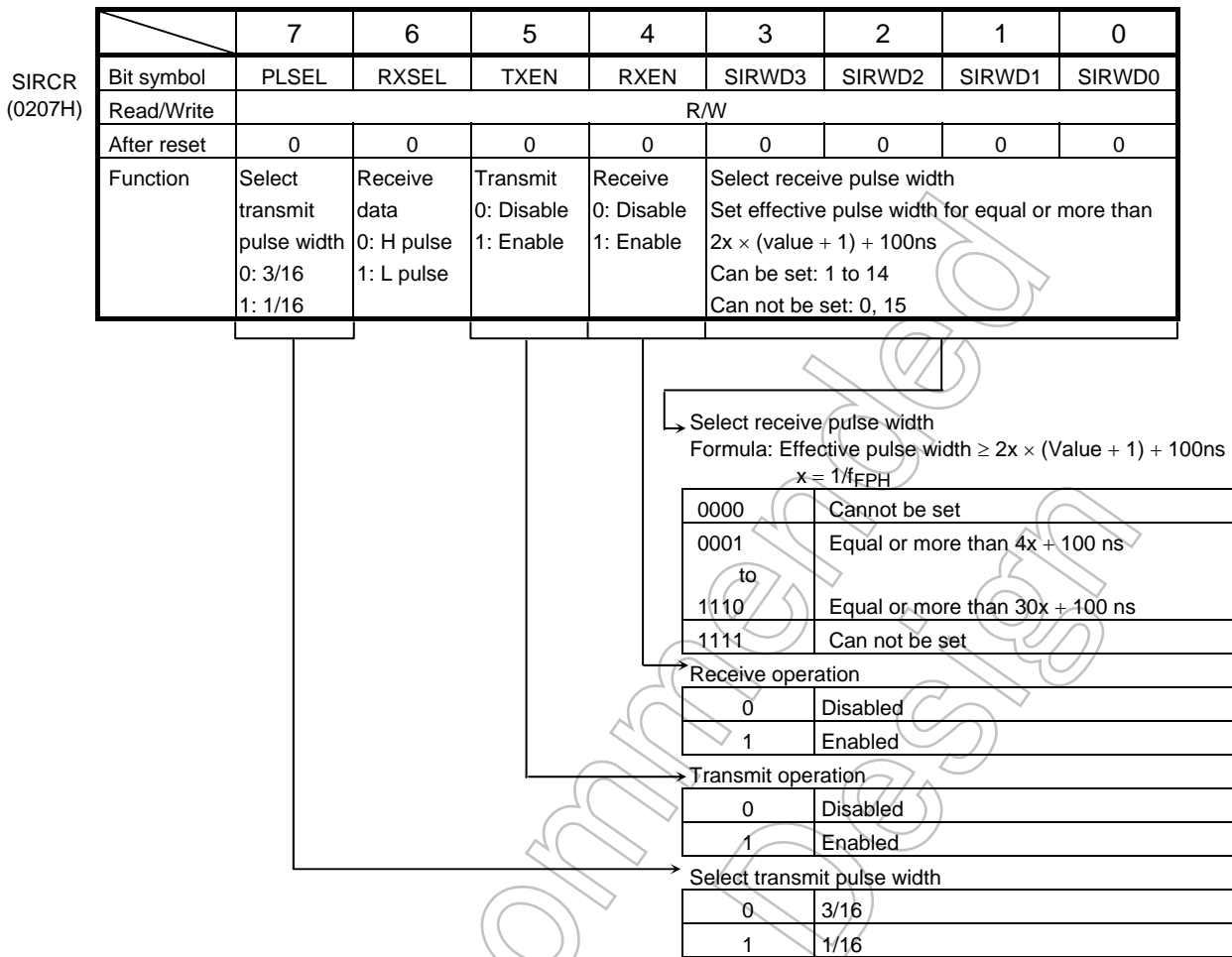

Figure 3.9.27 IrDA Control Register

Not Recommended for New

3.10 Serial Bus Interface (SBI)

The TMP91FY42 has a 1-channel serial bus interface which employs a clocked-synchronous 8-bit SIO mode and an I²C bus mode.

The serial bus interface is connected to an external device through P61 (SDA) and P62 (SCL) in the I²C bus mode; and through P60 (SCK), P61 (SO) and P62 (SI) in the clocked-synchronous 8-bit SIO mode.

Each pin is specified as follows.

	ODE<ODE62:61>	P6CR<P62C:60C>	P6FC<P62F:60F>
I ² C bus mode	11	11X	11X
Clocked synchronous 8-bit SIO mode	XX	011 010	111

X: Don't care

3.10.1 Configuration

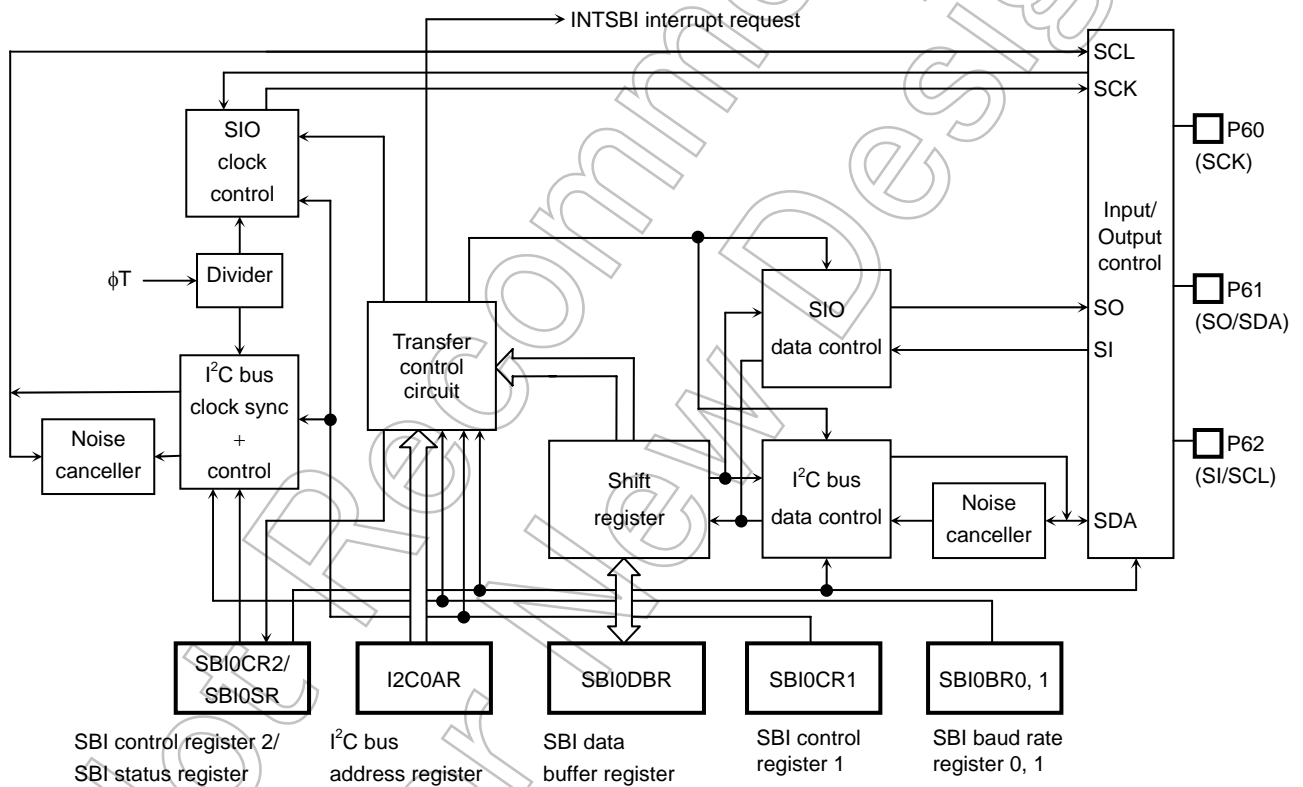

Figure 3.10.1 Serial Bus Interface (SBI)

3.10.2 Serial Bus Interface (SBI) Control

The following registers are used to control the serial bus interface and monitor the operation status.

- Serial bus interface control register 1 (SBI0CR1)
- Serial bus interface control register 2 (SBI0CR2)
- Serial bus interface data buffer register (SBI0DBR)
- I²C bus address register (I2C0AR)
- Serial bus interface status register (SBI0SR)
- Serial bus interface baud rate register 0 (SBI0BR0)
- Serial bus interface baud rate register 1 (SBI0BR1)

The above registers differ depending on a mode to be used.

Refer to section 3.10.4 “I²C Bus Mode Control” and 3.10.7 “Clocked Synchronous 8-Bit SIO Mode Control”.

3.10.3 The Data Formats in the I²C Bus Mode

The data formats in the I²C bus mode is shown below.

(a) Addressing format

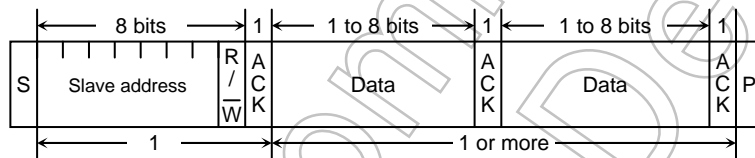

(b) Addressing format (with restart)

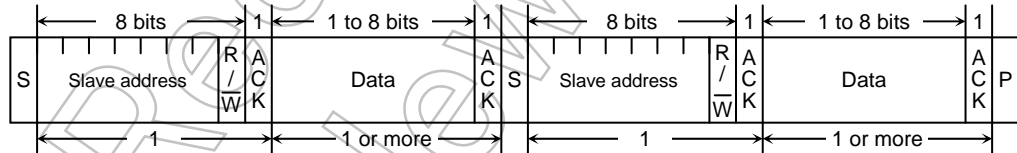

(c) Free data format (Data transferred from master device to slave device)

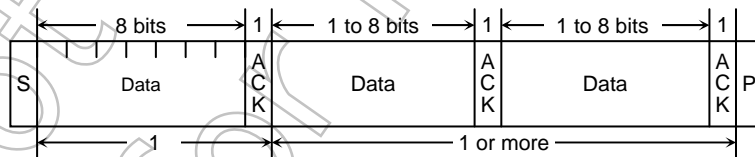

- S: Start condition
- R/ \bar{W} : Direction bit
- ACK: Acknowledge bit
- P: Stop condition

Figure 3.10.2 Data Format in the I²C Bus Mode

3.10.4 I²C Bus Mode Control

The following registers are used to control and monitor the operation status when using the serial bus interface (SBI) in the I²C bus mode.

Serial Bus Interface Control Register 1

		7	6	5	4	3	2	1	0
SBI0CR1 (0240H)	Bit symbol	BC2	BC1	BC0	ACK		SCK2	SCK1	SCK0/ SWRMON
	Read/Write	W			R/W		W		R/W
	After reset	0	0	0	0		0	0	0/1 (Note 3)
Prohibit read-modify-write	Function	Number of transferred bits (Note 1)			Acknowledge mode specification 0: Not generate 1: Generate		Internal serial clock selection and software reset monitor (Note 2)		

Internal serial clock selection <SCK2:0> at write

000	n = 5	– Note 4
001	n = 6	– Note 4
010	n = 7	– Note 4
011	n = 8	– Note 4
100	n = 9	51.9 kHz
101	n = 10	26.2 kHz
110	n = 11	13.1 kHz
111		(Reserved)

System clock: fc
Clock gear: fc/1
fc = 27 MHz
(internal SCL output)
 $f_{scl} = \frac{fc}{2^n + 8}$ [Hz]

Software reset state monitor <SWRMON> at read

0	During software reset
1	Initial data

Acknowledge mode specification

0	Not generate clock pulse for acknowledge signal
1	Generate clock pulse for acknowledge signal

Number of bits transferred

<BC2:0>	<ACK> = 0		<ACK> = 1	
	Number of clock pulses	Bits	Number of clock pulses	Bits
000	8	8	9	8
001	1	1	2	1
010	2	2	3	2
011	3	3	4	3
100	4	4	5	4
101	5	5	6	5
110	6	6	7	6
111	7	7	8	7

Note 1: Set the <BC2:0> to 000 before switching to a clock-synchronous 8-bit SIO mode.

Note 2: For the frequency of the SCL line clock, see 3.10.5 (3) Serial clock.

Note 3: Initial data of SCK0 is "0", SWRMON is "1".

Note 4: This I²C bus circuit does not support fast mode, it supports standard mode only. Although the I²C bus circuit itself allows the setting of a baud rate over 100kbps, the compliance with the I²C specification is not guaranteed in that case.

Figure 3.10.3 Registers for the I²C Bus Mode

Serial Bus Interface Control Register 2

		7	6	5	4	3	2	1	0
SBI0CR2 (0243H)	Bit symbol	MST	TRX	BB	PIN	SBIM1	SBIM0	SWRST1	SWRST0
	Read/Write	W				W (Note 1)		W (Note 1)	
	After reset	0	0	0	1	0	0	0	0
Prohibit read-modify-write	Function	Master/slave selection	Transmitter/receiver selection	Start/stop condition generation	Cancel INTSBI interrupt request	Serial bus interface operating mode selection (Note2) 00: Port mode 01: SIO mode 10: I ² C bus mode 11: (Reserved)		Software reset generate write 10 and 01, then an internal reset signal is generated.	

Serial bus interface operating mode selection (Note 2)	00	Port mode (Serial bus interface output disabled)
	01	Clocked synchronous 8-bit SIO mode
	10	I ² C bus mode
	11	(Reserved)

INTSBI interrupt request	0	Don't care
	1	Cancel interrupt request

Start/stop condition generation	0	Generates the stop condition
	1	Generates the start condition

Transmitter/receiver selection	0	Receiver
	1	Transmitter

Master/slave selection	0	Slave
	1	Master

Note 1: Reading this register function as SBIOSR register.

Note 2: Switch a mode to port mode after confirming that the bus is free.

Switch a mode between I²C bus mode and clock-synchronous 8-bit SIO mode after confirming that input signals via port are high level.

Figure 3.10.4 Registers for the I²C Bus Mode

Serial Bus Interface Status Register

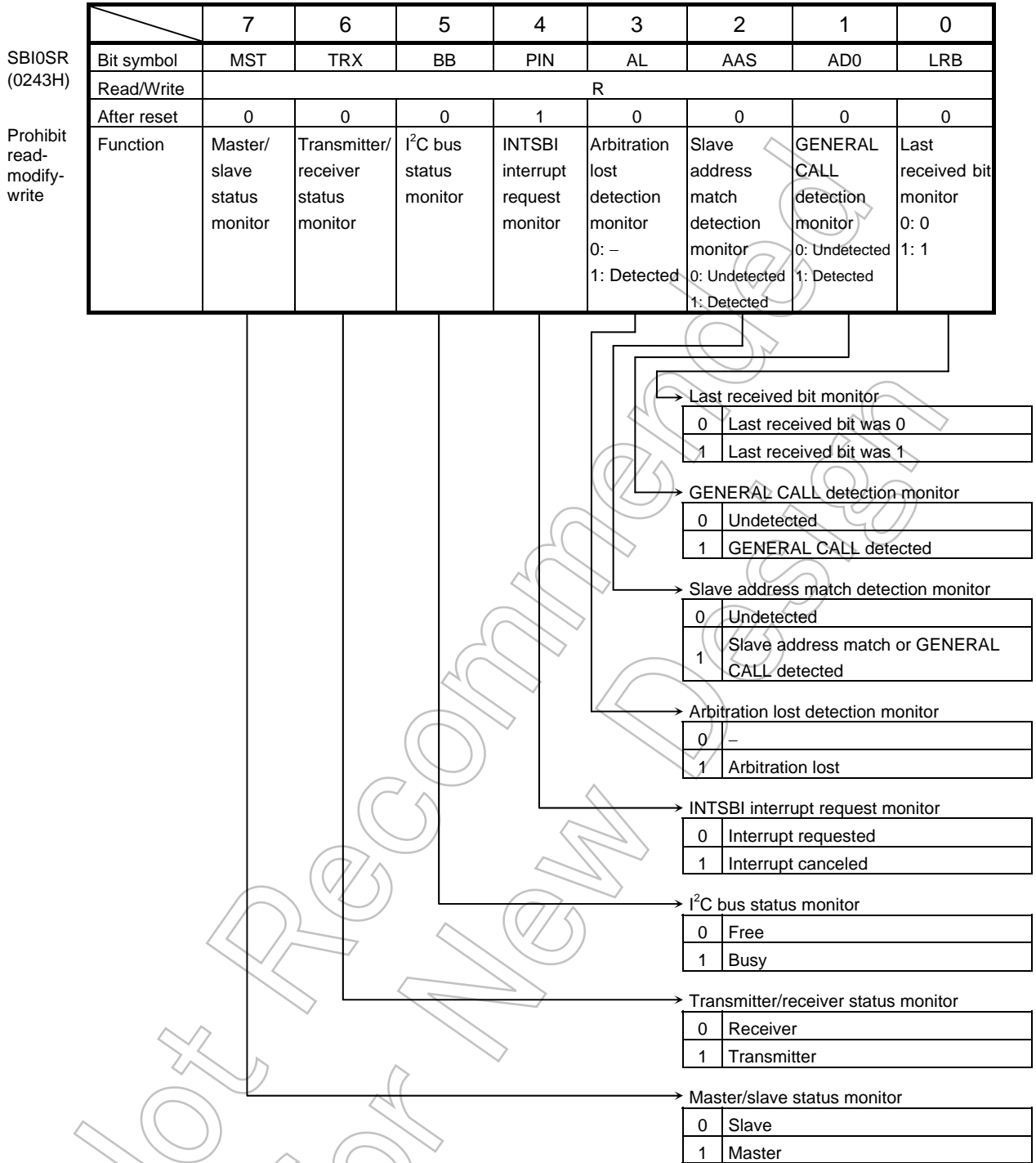

Note: Writing in this register functions as SBI0CR2.

Figure 3.10.5 Registers for the I²C Bus Mode

Serial Bus Interface Baud Rate Register 0

	7	6	5	4	3	2	1	0
SBI0BR0 (0244H)	Bit symbol	–	I2SBI0					
Prohibit read-modify-write	Read/Write	W	R/W					
	After reset	0	0					
	Function	Always write 0	IDLE2 0: Stop 1: Run					

Operation during IDLE 2 mode

0	Stop
1	Operation

Serial Bus Interface Baud Rate Register 1

	7	6	5	4	3	2	1	0
SBI0BR1 (0245H)	Bit symbol	P4EN	–					
Prohibit read-modify-write	Read/Write	W						
	After reset	0	0					
	Function	Internal clock 0: Stop 1: Operate	Always write 0					

Baud rate clock control

0	Stop
1	Operate

Serial Bus Interface Data Buffer Register

	7	6	5	4	3	2	1	0	
SBI0DBR (0241H)	Bit symbol	DB7	DB6	DB5	DB4	DB3	DB2	DB1	DB0
Prohibit read-modify-write	Read/Write	R (Received)/W (Transfer)							
	After reset	Undefined							

Note 1: When writing transmitted data, start from the MSB (Bit7). Receiving data is placed from LSB (Bit0).
 Note 2: SBI0DBR can't be read the written data. Therefore read-modify-write instruction (e.g., "BIT" instruction) is prohibited.

I²C Bus Address Register

	7	6	5	4	3	2	1	0	
I2C0AR (0242H)	Bit symbol	SA6	SA5	SA4	SA3	SA2	SA1	SA0	ALS
Prohibit read-modify-write	Read/Write	W							
	After reset	0	0	0	0	0	0	0	0
	Function	Slave address selection for when device is operating as slave device							Address recognition mode specification

Address recognition mode specification

0	Slave address recognition
1	Non slave address recognition

Figure 3.10.6 Registers for the I²C Bus Mode

3.10.5 Control in I²C Bus Mode

(1) Acknowledge mode specification

Set the SBI0CR1<ACK> to 1 for operation in the acknowledge mode. The TMP91FY42 generates an additional clock pulse for an acknowledge signal when operating in master mode. In the transmitter mode during the clock pulse cycle, the SDA pin is released in order to receive the acknowledge signal from the receiver. In the receiver mode during the clock pulse cycle, the SDA pin is set to the low in order to generate the acknowledge signal.

Clear the <ACK> to 0 for operation in the non-acknowledge mode, The TMP91FY42 does not generate a clock pulse for the acknowledge signal when operating in the master mode.

(2) Number of transfer bits

The SBI0CR1<BC2:0> is used to select a number of bits for next transmitting and receiving data.

Since the <BC2:0> is cleared to 000 as a start condition, a slave address and direction bit transmission are executed in 8 bits. Other than these, the <BC2:0> retains a specified value.

(3) Serial clock

a. Clock source

The SBI0CR1<SCK2:0> is used to select a maximum transfer frequency outputted on the SCL pin in master mode. Set a communication baud rate that meets the I²C bus specification, such as the shortest pulse width of t_{LOW}, based on the equations shown below.

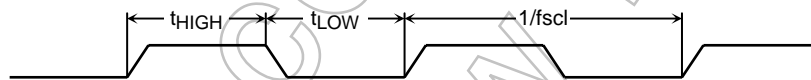

$$t_{LOW} = 2^{n-1} / f_{SBI}$$

$$t_{HIGH} = 2^{n-1} / f_{SBI} + 8 / f_{SBI}$$

$$f_{scl} = 1 / (t_{LOW} + t_{HIGH})$$

$$= \frac{f_{SBI}}{2^n + 8}$$

SBI0CR1<SCK2:0>	n
000	5
001	6
010	7
011	8
100	9
101	10
110	11

Note 1: f_{SBI} is the clock f_{PPH}.

Note 2: It's prohibited to use fc/16 prescaler clock when using SBI block. (I²C bus and clock synchronous.)

Figure 3.10.7 Clock Source

b. Clock synchronization

In the I²C bus mode, in order to wired-AND a bus, a master device which pulls down a clock line to low level, in the first place, invalidate a clock pulse of another master device which generates a high-level clock pulse. The master device with a high-level clock pulse needs to detect the situation and implement the following procedure.

The TMP91FY42 has a clock synchronization function for normal data transfer even when more than one master exists on the bus.

The example explains the clock synchronization procedures when two masters simultaneously exist on a bus.

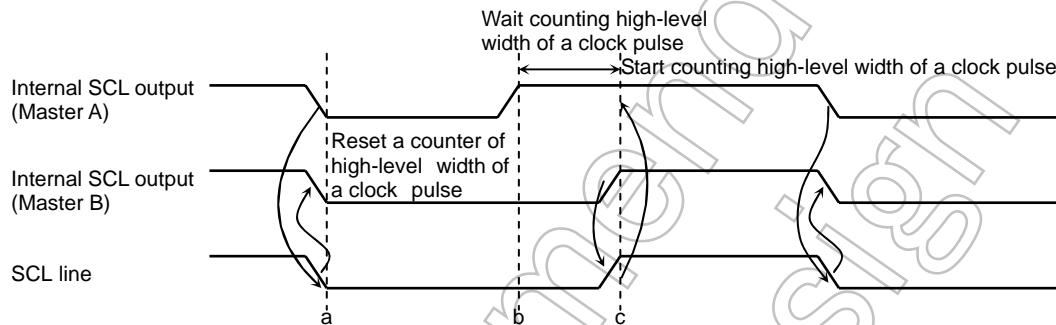

Figure 3.10.8 Clock Synchronization

As master A pulls down the internal SCL output to the low level at point a, the SCL line of the bus becomes the low level. After detecting this situation, master B resets a counter of high-level width of an own clock pulse and sets the internal SCL output to the low level.

Master A finishes counting low-level width of an own clock pulse at point b and sets the internal SCL output to the high level. Since master B holds the SCL line of the bus at the low level, master A wait for counting high-level width of an own clock pulse. After master B finishes counting low-level width of an own clock pulse at point c and master A detects the SCL line of the bus at the high level, and starts counting high level of an own clock pulse. The clock pulse on the bus is determined by the master device with the shortest high-level width and the master device with the longest low-level width from among those master devices connected to the bus.

(4) Slave address and address recognition mode specification

When the TMP91FY42 is used as a slave device, set the slave address <SA6:0> and <ALS> to the I2C0AR. Clear the <ALS> to 0 for the address recognition mode.

(5) Master/slave selection

Set the SBI0CR2<MST> to 1 for operating the TMP91FY42 as a master device. Clear the SBI0CR2<MST> to 0 for operation as a slave device. The <MST> is cleared to 0 by the hardware after a stop condition on the bus is detected or arbitration is lost.

(6) Transmitter/receiver selection

Set the SBI0CR2<TRX> to 1 for operating the TMP91FY42 as a transmitter. Clear the <TRX> to 0 for operation as a receiver. When data with an addressing format is transferred in slave mode, when a slave address with the same value that an I2C0AR or a GENERAL CALL is received (All 8-bit data are 0 after a start condition), the <TRX> is set to 1 by the hardware if the direction bit (R/W) sent from the master device is 1, and is cleared to 0 by the hardware if the bit is 0. In the master mode, after an acknowledge signal is returned from the slave device, the <TRX> is cleared to 0 by the hardware if a transmitted direction bit is 1, and is set to 1 by the hardware if it is 0. When an acknowledge signal is not returned, the current condition is maintained.

The <TRX> is cleared to 0 by the hardware after a stop condition on the I²C bus is detected or arbitration is lost.

(7) Start/stop condition generation

When the SBI0SR<BB> is 0, slave address and direction bit which are set to SBI0DBR are output on a bus after generating a start condition by writing 1 to the SBI0CR2<MST, TRX, BB, PIN>. It is necessary to set transmitted data to the data buffer register SBI0DBR and set 1 to <ACK> beforehand.

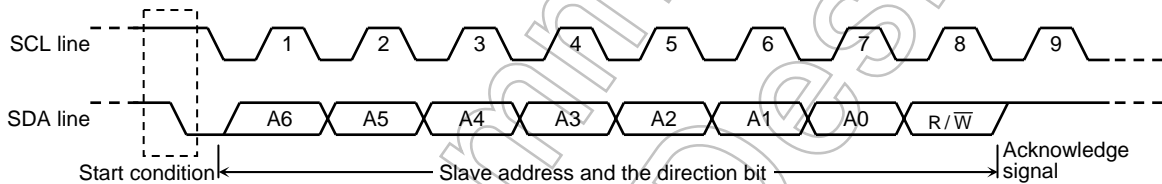

Figure 3.10.9 Start Condition Generation and Slave Address Generation

When the <BB> is 1, a sequence of generating a stop condition is started by writing 1 to the <MST, TRX, PIN>, and 0 to the <BB>. Do not modify the contents of <MST, TRX, BB, PIN> until a stop condition is generated on a bus.

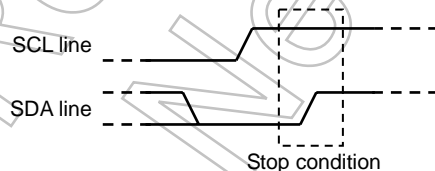

Figure 3.10.10 Stop Condition Generation

The state of the bus can be ascertained by reading the contents of SBI0SR<BB>. SBI0SR<BB> will be set to 1 if a start condition has been detected on the bus, and will be cleared to 0 if a stop condition has been detected.

And about generation of stop condition in master mode, there are some limitation point. Please refer to the 3.10.6 (4) "Stop condition generation".

(8) Interrupt service requests and interrupt cancellation

When a serial bus interface interrupt request (INTSBI) occurs, the SBI0CR2<PIN> is cleared to 0. During the time that the SBI0CR2<PIN> is 0, the SCL line is pulled down to the low level.

The <PIN> is cleared to 0 when a 1 word of data is transmitted or received. Either writing/reading data to/from SBI0DBR sets the <PIN> to 1.

The time from the <PIN> being set to 1 until the SCL line is released takes t_{LOW} .

In the address recognition mode (<ALS> = 0), <PIN> is cleared to 0 when the received slave address is the same as the value set at the I2COAR or when a GENERAL CALL is received (All 8-bit data are 0 after a start condition). Although SBI0CR2<PIN> can be set to 1 by the program, the <PIN> is not clear it to 0 when it is written 0.

(9) Serial bus interface operation mode selection

SBI0CR2<SBIM1:0> is used to specify the serial bus interface operation mode. Set SBI0CR2<SBIM1:0> to 10 when the device is to be used in I²C bus mode after confirming pin condition of serial bus interface to "H".

Switch a mode to port after confirming a bus is free.

(10) Arbitration lost detection monitor

Since more than one master device can exist simultaneously on the bus in I²C bus mode, a bus arbitration procedure has been implemented in order to guarantee the integrity of transferred data.

Data on the SDA line is used for I²C bus arbitration.

The following shows an example of a bus arbitration procedure when two master devices exist simultaneously on the bus. Master A and master B output the same data until point a. After master A outputs "L" and master B, "H", the SDA line of the bus is wire-AND and the SDA line is pulled down to the low level by master A. When the SCL line of the bus is pulled up at point b, the slave device reads the data on the SDA line, that is, data in master A. A data transmitted from master B becomes invalid. The state in master B is called arbitration lost. Master B device which loses arbitration releases the internal SDA output in order not to affect data transmitted from other masters with arbitration. When more than one master sends the same data at the first word, arbitration occurs continuously after the second word.

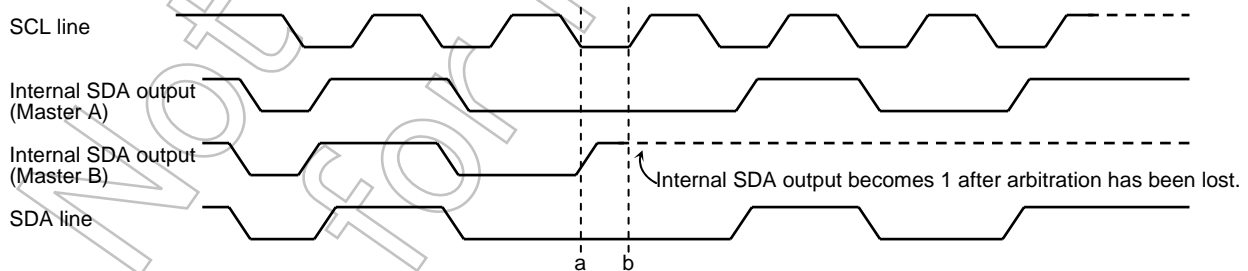

Figure 3.10.11 Arbitration Lost

The TMP91FY42 compares the levels on the bus's SDA line with those of the internal SDA output on the rising edge of the SCL line. If the levels do not match, arbitration is lost and SBI0SR<AL> is set to 1.

When SBI0SR<AL> is set to 1, SBI0SR<MST, TRX> are cleared to 00 and the mode is switched to slave receiver mode. Thus, clock output is stopped in data transfer after setting <AL> = "1".

SBI0SR<AL> is cleared to 0 when data is written to or read from SBI0DBR or when data is written to SBI0CR2.

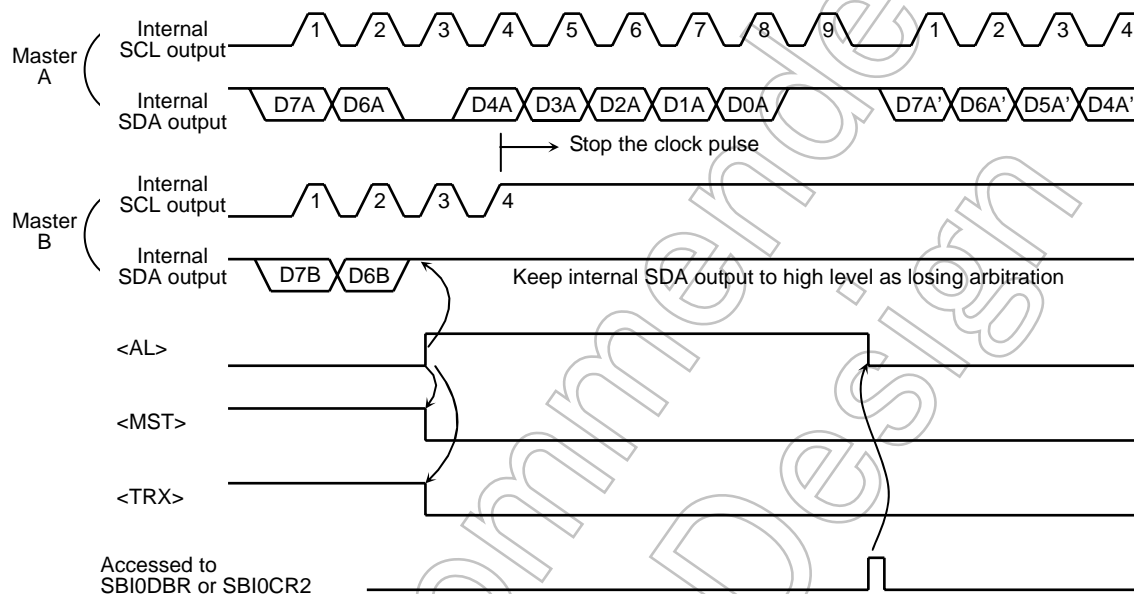

Figure 3.10.12 Example of when TMP91CW12 is a Master Device B
(D7A = D7B, D6A = D6B)

(11) Slave address match detection monitor

SBI0SR<AAS> is set to 1 in slave mode, in address recognition mode (e.g., when I2C0AR<ALS> = 0), when a GENERAL CALL is received, or when a slave address matches the value set in I2C0AR. When I2C0AR<ALS> = 1, SBI0SR<AAS> is set to 1 after the first word of data has been received. SBI0SR<AAS> is cleared to 0 when data is written to or read from the data buffer register SBI0DBR.

(12) GENERAL CALL detection monitor

SBI0SR<AD0> is set to 1 in slave mode, when a GENERAL CALL is received (All 8-bit received data is 0, after a start condition). SBI0SR<AD0> is cleared to 0 when a start condition or stop condition is detected on the bus.

(13) Last received bit monitor

The SDA line value stored at the rising edge of the SCL line is set to the SBI0SR<LRB>. In the acknowledge mode, immediately after an INTSBI interrupt request is generated, an acknowledge signal is read by reading the contents of the SBI0SR<LRB>.

(14) Software reset function

The software reset function is used to initialize the SBI circuit, when SBI is locked by external noises, etc.

An internal reset signal pulse can be generated by setting SBI0CR2<SWRST1:0> to 10 and 01. This initializes the SBI circuit internally. All command (except SBI0CR2<SBIM1:0>) registers and status registers are initialized as well.

SBI0CR1<SWRMON> is automatically set to “1” after the SBI circuit has been initialized.

(15) Serial bus interface data buffer register (SBI0DBR)

The received data can be read and transferred data can be written by reading or writing the SBI0DBR.

In the master mode, after the start condition is generated the slave address and the direction bit are set in this register.

(16) I²C bus address register (I2C0AR)

I2C0AR<SA6:0> is used to set the slave address when the TMP91FY42 functions as a slave device.

The slave address output from the master device is recognized by setting the I2C0AR<ALS> to 0. The data format is the addressing format. When the slave address is not recognized at the <ALS> = 1, the data format is the free data format.

(17) Baud rate register (SBI0BR1)

Write 1 to SBI0BR1<P4EN> before operation commences.

(18) Setting register for IDLE2 mode operation (SBI0BR0)

SBI0BR0<I2SBI0> is the register setting operation/stop during IDLE2 mode. Therefore, setting <I2SBI0> is necessary before the HALT instruction is executed.

Not Recommended for New

3.10.6 Data Transfer in I²C Bus Mode

(1) Device initialization

Set the SBI0BR1<P4EN>, SBI0CR1<ACK, SCK2:0>, Set SBI0BR1 to 1 and clear bits 7 to 5 and 3 in the SBI0CR1 to 0.

Set a slave address <SA6:0> and the <ALS> (<ALS> = 0 when an addressing format) to the I2C0AR.

For specifying the default setting to a slave receiver mode, clear 0 to the <MST, TRX, BB> and set 1 to the <PIN>, 10 to the <SBIM1:0>.

(2) Start condition and slave address generation

a. Master mode

In the master mode, the start condition and the slave address are generated as follows.

Check a bus free status (when <BB> = 0).

Set the SBI0CR1<ACK> to 1 (Acknowledge mode) and specify a slave address and a direction bit to be transmitted to the SBI0DBR.

When SBI0CR2<BB> = 0, the start condition are generated by writing 1111 to SBI0CR2<MST, TRX, BB, PIN>. Subsequently to the start condition, nine clocks are output from the SCL pin. While eight clocks are output, the slave address and the direction bit which are set to the SBI0DBR. At the 9th clock, the SDA line is released and the acknowledge signal is received from the slave device.

An INTSBI interrupt request occurs at the falling edge of the 9th clock. The <PIN> is cleared to 0. In the master mode, the SCL pin is pulled down to the low level while <PIN> is 0. When an interrupt request occurs, the <TRX> is changed according to the direction bit only when an acknowledge signal is returned from the slave device.

b. Slave mode

In the slave mode, the start condition and the slave address are received.

After the start condition is received from the master device, while eight clocks are output from the SCL pin, the slave address and the direction bit which are output from the master device are received.

When a GENERAL CALL or the same address as the slave address set in I2C0AR is received, the SDA line is pulled down to the low level at the 9th clock, and the acknowledge signal is output.

An INTSBI interrupt request occurs on the falling edge of the 9th clock. The <PIN> is cleared to 0. In slave mode the SCL line is pulled down to the low level while the <PIN> = 0.

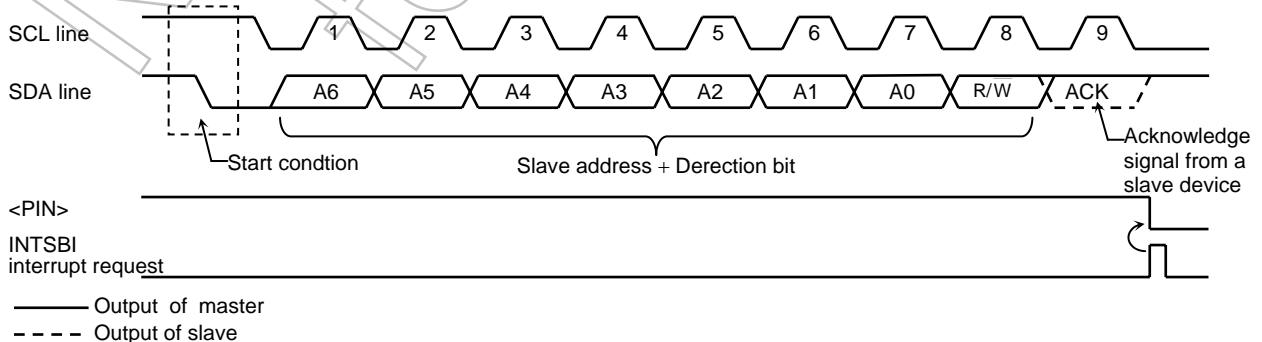

Figure 3.10.13 Start Condition Generation and Slave Address Transfer

(3) 1-word data transfer

Check the <MST> by the INTSBI interrupt process after the 1-word data transfer is completed, and determine whether the mode is a master or slave.

a. If <MST> = 1 (Master mode)

Check the <TRX> and determine whether the mode is a transmitter or receiver.

When the <TRX> = 1 (Transmitter mode)

Check the <LRB>. When <LRB> is 1, a receiver does not request data. Implement the process to generate a stop condition (Refer to 3.10.6 (4)) and terminate data transfer.

When the <LRB> is 0, the receiver requests new data. When the next transmitted data is 8 bits, write the transmitted data to SBI0DBR. When the next transmitted data is other than 8 bits, set the BC<2:0> <ACK> and write the transmitted data to SBI0DBR. After written the data, <PIN> becomes 1, a serial clock pulse is generated for transferring a new 1 word of data from the SCL pin, and then the 1-word data is transmitted. After the data is transmitted, an INTSBI interrupt request occurs. The <PIN> becomes 0 and the SCL line is pulled down to the low level. If the data to be transferred is more than 1 word in length, repeat the procedure from the <LRB> checking above.

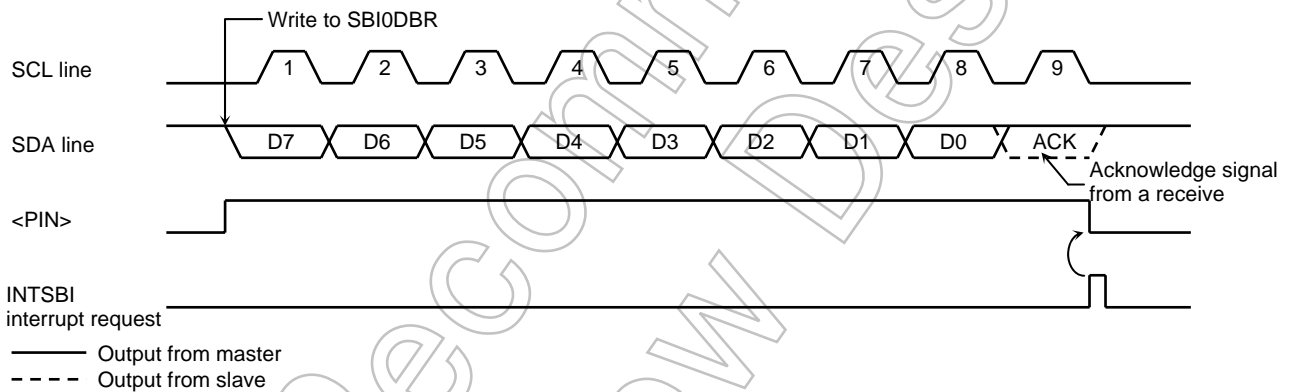

Figure 3.10.14 Example in which BC<2:0> = 000 and <ACK> = 1 in Transmitter Mode

When the <TRX> is 0 (Receiver mode)

When the next transmitted data is other than 8 bits, set <BC2:0> <ACK> and read the received data from SBI0DBR to release the SCL line (data which is read immediately after a slave address is sent is undefined). After the data is read, <PIN> becomes 1. Serial clock pulse for transferring new 1 word of data is defined SCL and outputs “L” level from SDA pin with acknowledge timing.

An INTSBI interrupt request then occurs and the <PIN> becomes 0, Then the TMP91FY42F pulls down the SCL pin to the low level. The TMP91FY42 outputs a clock pulse for 1 word of data transfer and the acknowledge signal each time that received data is read from the SBI0DBR.

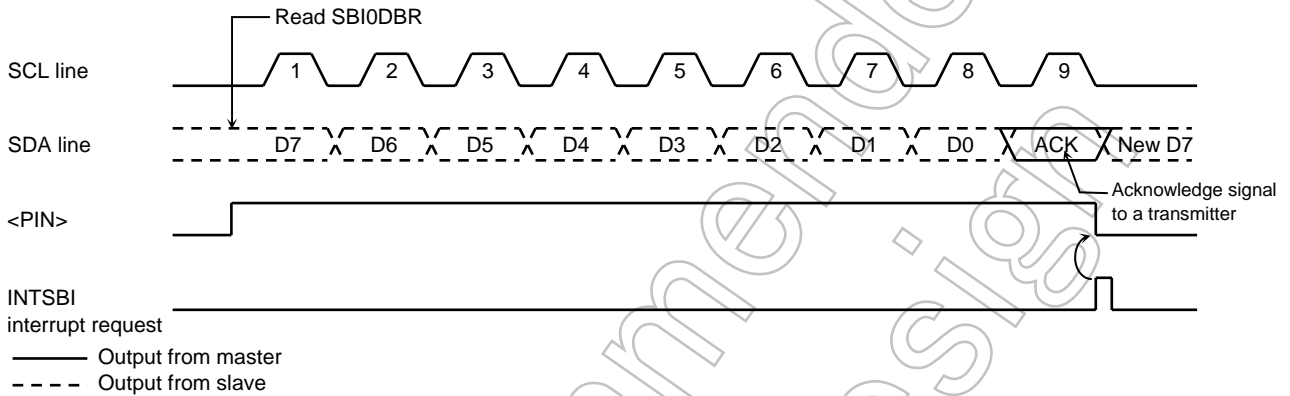

Figure 3.10.15 Example of when <BC2:0> = 000, <ACK> = 1 in Receiver Mode

In order to terminate the transmission of data to a transmitter, clear <ACK> to 0 before reading data which is 1 word before the last data to be received. The last data word does not generate a clock pulse as the acknowledge signal. After the data has been transmitted and an interrupt request has been generated, set BC<2:0> to 001 and read the data. The TMP91FY42 generates a clock pulse for a 1-bit data transfer. Since the master device is a receiver, the SDA line on the bus remains high. The transmitter interprets the high signal as an ACK signal. The receiver indicates to the transmitter that data transfer is complete.

After the one data bit has been received and an interrupt request been generated, the TMP91FY42 generates a stop condition (See Section 3.10.6 (4)) and terminates data transfer.

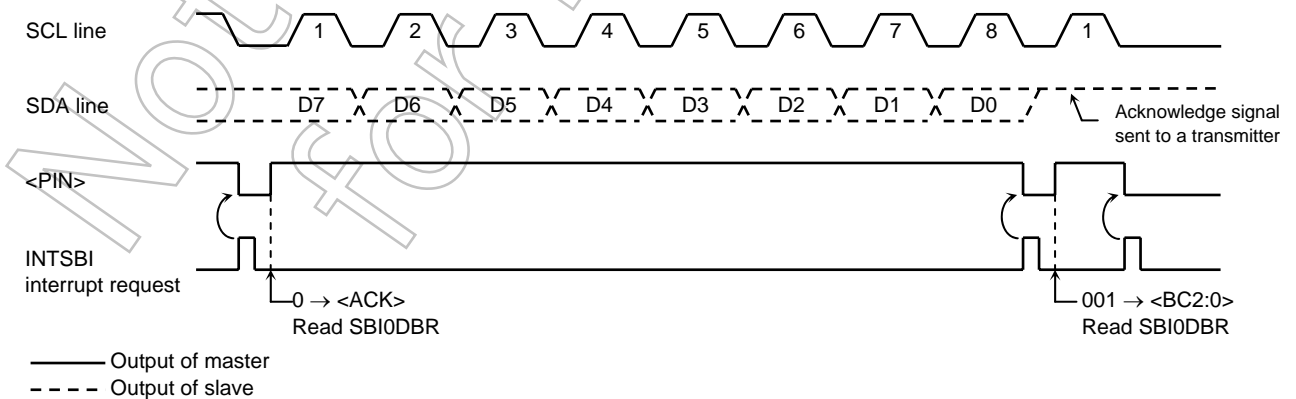

Figure 3.10.16 Termination of Data Transfer in Master Receiver Mode

b. If <MST> = 0 (Slave mode)

In the slave mode the TMP91FY42 operates either in normal slave mode or in slave mode after losing arbitration.

In the slave mode, an INTSBI interrupt request occurs when the TMP91FY42 receives a slave address or a GENERAL CALL from the master device, or when a GENERAL CALL is received and data transfer is complete, or after matching received address. In the master mode, the TMP91FY42 operates in a slave mode if it losing arbitration. An INTSBI interrupt request occurs when a word data transfer terminates after losing arbitration. When an INTSBI interrupt request occurs the <PIN> is cleared to 0 and the SCL pin is pulled down to the low level. Either reading/writing from/to the SBI0DBR or setting the <PIN> to 1 will release the SCL pin after taking t_{LOW} time.

Check the SBI0SR<AL>, <TRX>, <AAS>, and <AD0> and implements processes according to conditions listed in the next table.

Table 3.10.1 Operation in the Slave Mode

<TRX>	<AL>	<AAS>	<AD0>	Conditions	Process
1	1	1	0	The TMP91FY42 loses arbitration when transmitting a slave address and receives a slave address for which the value of the direction bit sent from another master is 1.	Set the number of bits a word in <BC2:0> and write the transmitted data to SBI0DBR
		0	0	In slave receiver mode the TMP91FY42 receives a slave address for which the value of the direction bit sent from the master is 1.	
	0	0	In slave transmitter mode a single word of is transmitted. Set BC<2:0> to the number of bits in a word.	Check the <LRB> setting. If <LRB> is set to 1, set <PIN> to 1 since the receiver win no request the data which follows. Then, cleat <TRX> to 0 to release the bus. If <LRB> is cleared to 0 of and write the transmitted data to SBI0DBR since the receiver requests next data.	
0	1	1	1/0	The TMP91FY42 loses arbitration when transmitting a slave address and receives a slave address or GENERAL CALL for which the value of the direction bit sent from another master is 0.	Read the SBI0DBR for setting the <PIN> to 1 (Reading dummy data) or set the <PIN> to 1.
		0	0	The TMP91FY42 loses arbitration when transmitting a slave address or data and terminates word data transfer.	
	0	1	1/0	In slave receiver mode the TMP91FY42 receives a slave address or GENERAL CALL for which the value of the direction bit sent from the master is 0.	
		0	1/0	In slave receiver mode the TMP91FY42 terminates receiving word data.	

(4) Stop condition generation

When $SBI0SR<BB> = 1$, the sequence for generating a stop condition can be initiated by writing 1 to $SBI0CR2<MST, TRX, PIN>$ and 0 to $SBI0CR2<BB>$. Do not modify the contents of $SBI0CR2<MST, TRX, PIN, BB>$ until a stop condition has been generated on the bus. When the bus's SCL line has been pulled low by another device, the TMP91FY42 generates a stop condition when the other device has released the SCL line.

When $SBI0CR2<MST, TRX, PIN>$ are written 1 and $<BB>$ is written 0, $<BB>$ changes to 0 by internal SCL changes to 1, without waiting stop condition.

To check whether SCL and SDA pin are 1 by sensing their ports is needed to detect bus free condition.

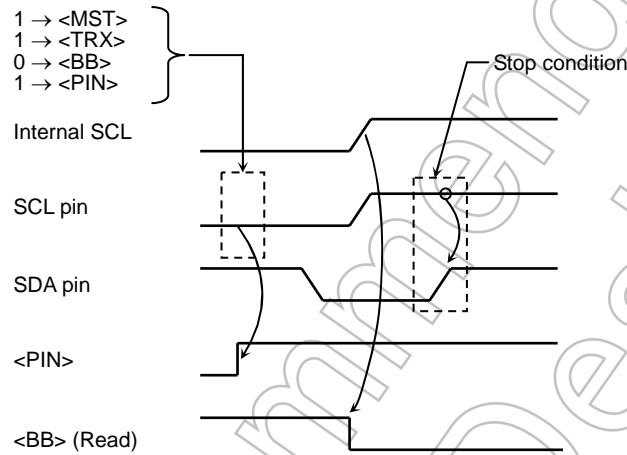

Figure 3.10.17 Stop Condition Generation (Single master)

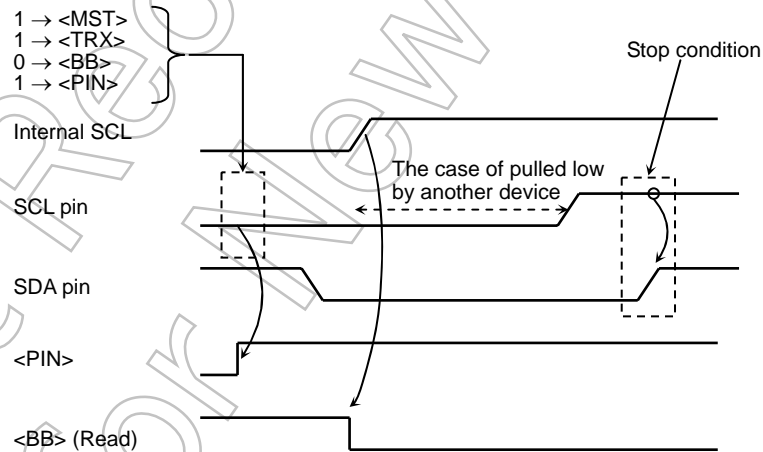

Figure 3.10.18 Stop Condition Generation (Multi master)

(5) Restart

Restart is used during data transfer between a master device and a slave device to change the data transfer direction. The following description explains how to restart when the TMP91FY42 is in master mode.

Clear SBI0CR2<MST, TRX, BB> to 0 and set SBI0CR2<PIN> to 1 to release the bus. The SDA line remains high and the SCL pin is released. Since a stop condition has not been generated on the bus, other devices assume the bus to be in busy state. Monitor the value of SBI0SR<BB> until it becomes 0 so as to ascertain when the TMP91FY42's SCL pin is released. Check the <LRB> until it becomes 1 to check that the SCL line on a bus is not pulled down to the low level by other devices. After confirming that the bus remains in a free state, generate a start condition using the procedure described in 3.10.6 (2).

In order to satisfy the setup time requirements when restarting, take at least 4.7 μ s of waiting time by software from the time of restarting to confirm that the bus is free until the time to generate the start condition.

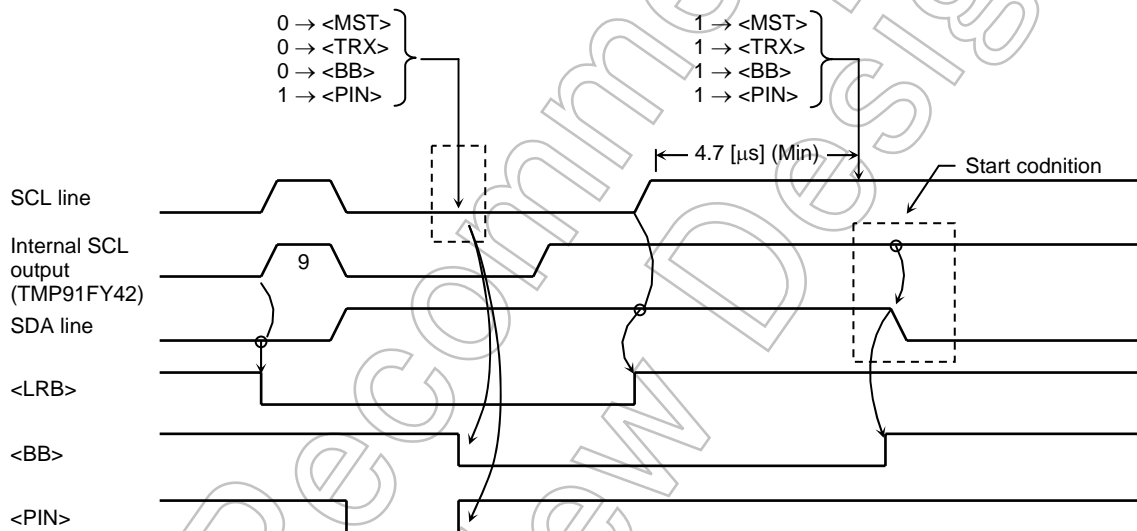

Figure 3.10.19 Timing Diagram for TMP91FY42F Restart

3.10.7 Clocked Synchronous 8-Bit SIO Mode Control

The following registers are used to control and monitor the operation status when the serial bus interface (SBI) is being operated in clocked synchronous 8-bit SIO mode.

Serial Bus Interface Control Register 1

		7	6	5	4	3	2	1	0
SBI0CR1 (0240H)	Bit symbol	SIOS	SIOINH	SIOM1	SIOM0		SCK2	SCK1	SCK0
	Read/Write	W					W		W
Prohibit read-modify-write	After reset	0	0	0	0		0	0	0
	Function	Transfer start 0: Stop 1: Start	Continue/abort transfer 0: Continue transfer 1: Abort transfer	Transfer mode select 00: Transmit mode 01: (Reserved) 10: Transmit/receive mode 11: Receive mode			Serial clock selection and reset monitor		

Serial clock selection <SCK2:0> at write		
000	n = 4	1.7 MHz
001	n = 5	843.8 kHz
010	n = 6	421.9 kHz
011	n = 7	210.9 kHz
100	n = 8	105.5 kHz
101	n = 9	52.7 kHz
110	n = 10	26.4 kHz
111	-	External mode

System clock: fc
Clock gear: fc/1
fc = 27 MHz
(Output to SCK pin)
 $f_{scl} = \frac{fc}{2^n}$ [Hz]
(Input from SCK terminal)

Transfer mode selection	
00	8-bit transmit mode
01	(Reserved)
10	8-bit transmit/received mode
11	8-bit received mode

Continue/abort transfer	
0	Continue transfer
1	Abort transfer (Automatically cleared after transfer aborted)

Transfer start/stop	
0	Stopped
1	Started

Note: Set the transfer mode and the serial clock after setting <SIOS> to 0 and <SIOINH> to 1.

Serial Bus Interface Data Buffer Register

		7	6	5	4	3	2	1	0
SBI0DBR (0241H)	Bit symbol	DB7	DB6	DB5	DB4	DB3	DB2	DB1	DB0
	Read/Write	R (Receiver)/W (Transfer)							
Prohibit read-modify-write	After reset	Undefined							

Figure 3.10.20 Register for the SIO Mode

Serial Bus Interface Control Register 2

	7	6	5	4	3	2	1	0
SBI0CR2 (0243H)	Bit symbol				SBIM1	SBIM0	-	-
	Read/Write				W		W	W
	After reset				0	0	0	0
Prohibit read-modify-write	Function				Serial bus interface operation mode selection 00: Port mode 01: SIO mode 10: I ² C bus mode 11: (Reserved)		(Note 2)	(Note 2)

Serial bus interface operation mode selection

00	Port mode (Serial bus interface output disabled)
01	Clocked synchronous 8-bit SIO mode
10	I ² C bus mode
11	(Reserved)

Note 1: Set the SBI0CR1<BC2:0> 000 before switching to a clocked synchronous 8-bit SIO mode.

Note 2: Please always write SBICR2<1:0> to "00".

Serial Bus Interface Status Register

	7	6	5	4	3	2	1	0
SBI0SR (0243H)	Bit symbol				SIOF	SEF		
	Read/Write				R			
	After reset				0	0		
	Function				Serial transfer operation status monitor	Shift operation status monitor		

Shift operation status monitor

0	Shift operation terminated
1	Shift operation in progress

Serial transfer operating status monitor

0	Transfer terminated
1	Transfer in progress

Figure 3.10.21 Registers for the SIO Mode

Serial Bus Interface Baud Rate Register 0

	7	6	5	4	3	2	1	0
SBI0BR0 (0244H) Prohibit read-modify-write	Bit symbol	-	I2SBI0					
	Read/Write	W	R/W					
	After reset	0	0					
	Function	Always write 0	IDLE2 0: Stop 1: Operate					

Operation in IDLE2 mode

0	Stop
1	Operate

Serial Bus Interface Baud Rate Register 1

	7	6	5	4	3	2	1	0
SBI0BR1 (0245H) Prohibit read-modify-write	Bit symbol	P4EN	-					
	Read/Write	W						
	After reset	0	0					
	Function	Internal clock 0: Stop 1: Operate	Always write 0					

Baud rate clock control

0	Stop
1	Operate

Figure 3.10.22 Registers for the SIO Mode

Not Recommended for New Design

(1) Serial clock

a. Clock source

SBI0CR1<SCK2:0> is used to select the following functions:

Internal clock

In internal clock mode one of seven frequencies can be selected. The serial clock signal is output to the outside on the SCK pin.

When the device is writing (in transmit mode) or reading (in receive mode), data cannot follow the serial clock rate, so an automatic wait function is executed which automatically stops the serial clock and holds the next shift operation until reading or writing has been completed.

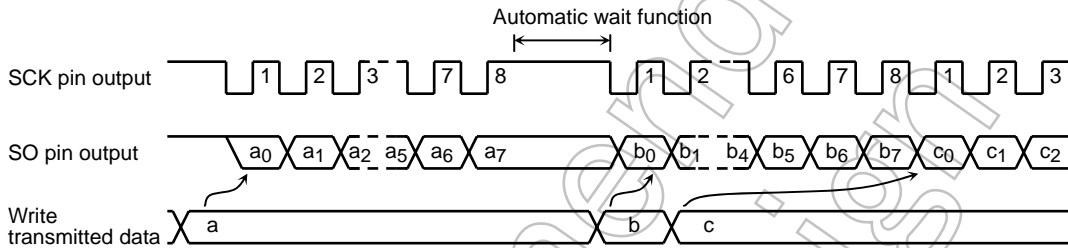

Figure 3.10.23 Automatic Wait Function

External clock (<SCK2:0> = 111)

An external clock input via the SCK pin is used as the serial clock. In order to ensure the integrity of shift operations, both the high and low-level serial clock pulse widths shown below must be maintained. The maximum data transfer frequency is 1.7 MHz (when $f_c = 27$ MHz).

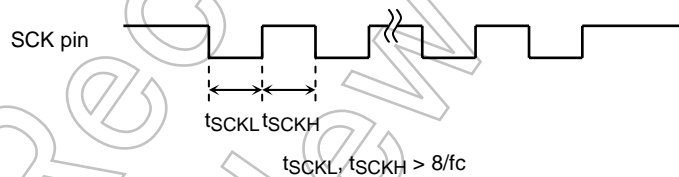

Figure 3.10.24 Maximum Data Transfer Frequency when External Clock Input Used

b. Shift edge

Data is transmitted on the leading edge of the clock and received on the trailing edge.

Leading edge shift

Data is shifted on the leading edge of the serial clock (on the falling edge of the SCK pin input/output).

Trailing edge shift

Data is shifted on the trailing edge of the serial clock (on the rising edge of the SCK pin input/output).

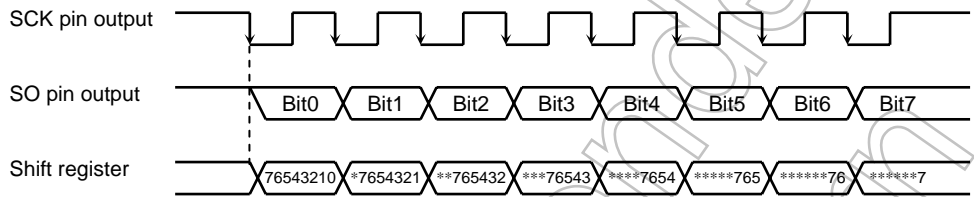

(a) Leading edge

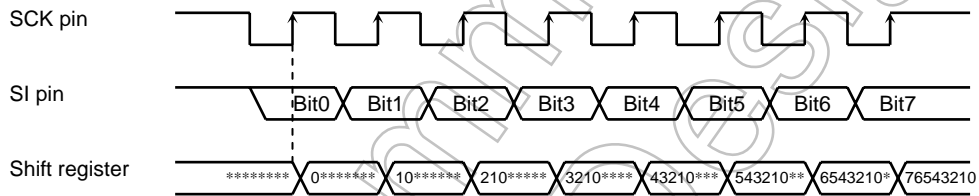

*: Don't care

(b) Trailing edge

Figure 3.10.25 Shift Edge

Not Recommended for New

(2) Transfer modes

The SBI0CR1<SIOM1:0> is used to select a transmit, receive or transmit/receive mode.

a. 8-bit transmit mode

Set a control register to a transmit mode and write transmit data to the SBI0DBR.

After the transmit data is written, set the SBI0CR1<SIOS> to 1 to start data transfer. The transmitted data is transferred from SBI0DBR to the shift register and output to the SO pin in synchronized with the serial clock, starting from the least significant bit (LSB). When the transmission data is transferred to the shift register, the SBI0DBR becomes empty. An INTSBI (Buffer empty) interrupt request is generated to request new data.

When the internal clock is used, the serial clock will stop and automatic-wait function will be initiated if new data is not loaded to the data buffer register after the specified 8-bit data is transmitted. When new transmit data is written, automatic-wait function is canceled.

When the external clock is used, data should be written to SBI0DBR before new data is shifted. The transfer speed is determined by the maximum delay time between the time when an interrupt request is generated and the time when data is written to SBI0DBR by the interrupt service program.

When the transmit is started, after the SBI0SR<SIOF> goes 1 output from the SO pin holds final bit of the last data until falling edge of the SCK.

Transmitting data is ended by clearing the <SIOS> to 0 by the buffer empty interrupt service program or setting the <SIOINH> to 1. When the <SIOS> is cleared, the transmitted mode ends when all data is output. In order to confirm if data is surely transmitted by the program, set the <SIOF> (Bit3 of SBI0SR) to be sensed. The SBI0SR<SIOF> is cleared to 0 when transmitting is complete. When the <SIOINH> is set to 1, transmitting data stops. SBI0SR<SIOF> turns 0.

When an external clock is used, it is also necessary to clear SBI0SR<SIOS> to 0 before new data is shifted; otherwise, dummy data is transmitted and operation ends.

Example: Program to stop data transmission (when an external clock is used)

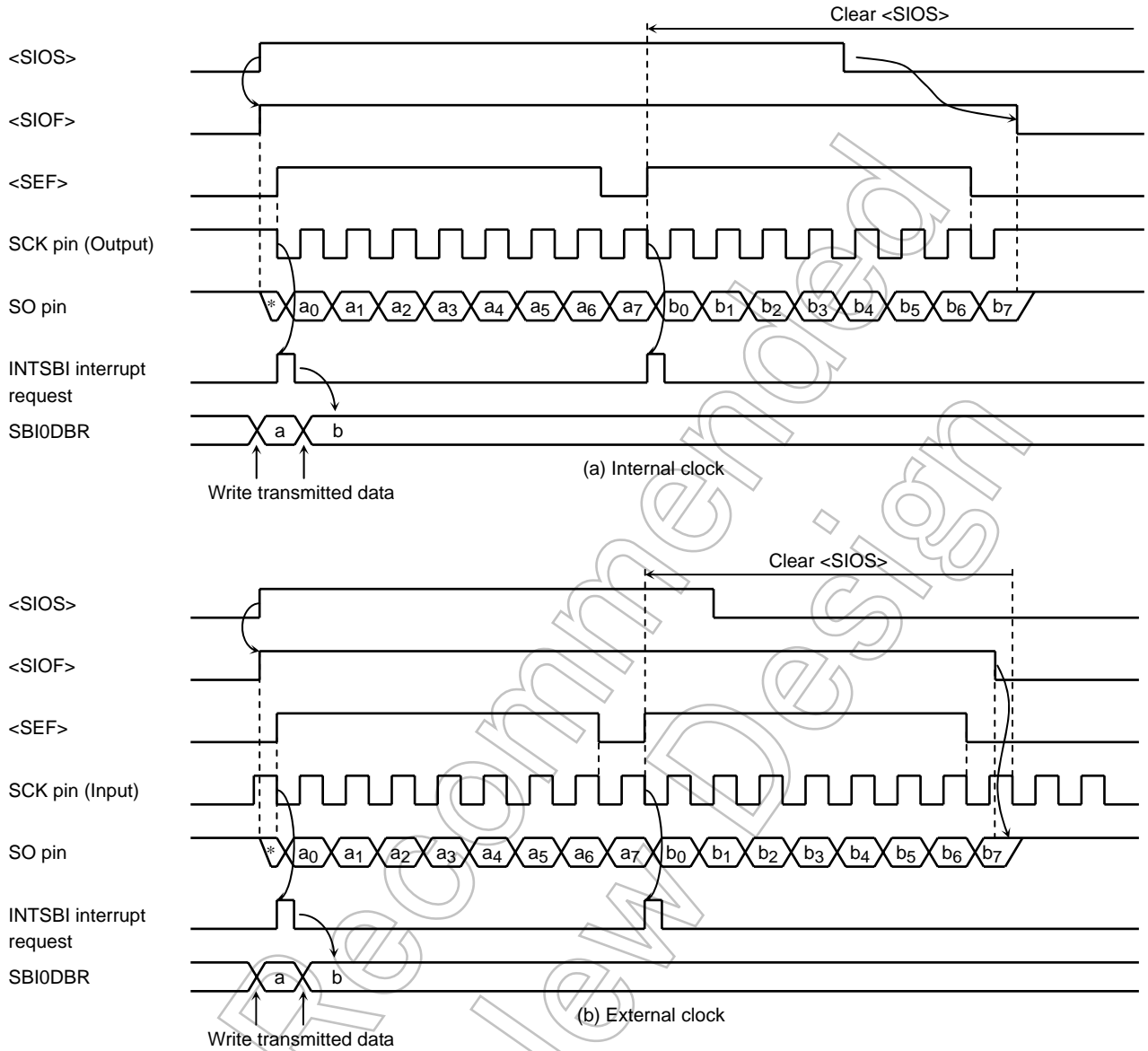

Figure 3.10.26 Transfer Mode

```

STEST1: BIT 2, (SBI0SR)           ; If <SEF> = 1 then loop
        JR  NZ, STEST1
STEST2: BIT 0, (P6)              ; If SCK = 0 then loop
        JR  Z, STEST2
        LD  (SBI0CR1), 00000111B ; <SIOS> ← 0
    
```

b. 8-bit receive mode

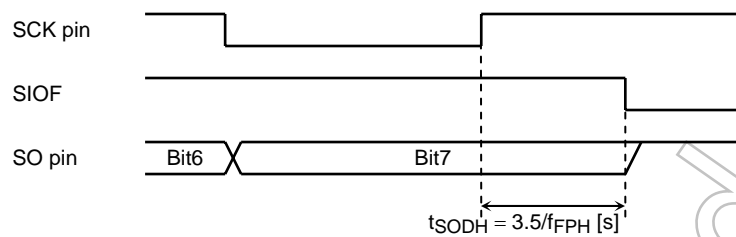

Figure 3.10.27 Transmitted Data Hold Time at End of Transmission

Set the control register to receive mode and set SBI0CR1<SIOS> to 1 for switching to receive mode. Data is received into the shift register via the SI pin and synchronized with the serial clock, starting from the least significant bit (LSB). When 8-bit data is received, the data is transferred from the shift register to SBI0DBR. An INTSBI (Buffer full) interrupt request is generated to request that the received data be read. The data is then read from SBI0DBR by the interrupt service program.

When an internal clock is used, the serial clock will stop and the automatic wait function will be in effect until the received data has been read from SBI0DBR.

When an external clock is used, since shift operation is synchronized with an external clock pulse, the received data should be read from SBI0DBR before the next serial clock pulse is input. If the received data is not read, any further data which is to be received is canceled. The maximum transfer speed when an external clock is used is determined by the delay time between the time when an interrupt request is generated and the time when the received data is read.

Receiving of data ends when <SIOS> is cleared to 0 by the buffer full interrupt service program or when <SIOINH> is set to 1. If <SIOS> is cleared to 0, received data is transferred to SBI0DBR in complete blocks. The received mode ends when the transfer is complete. In order to confirm whether data is being received properly by the program, set SBI0SR<SIOF> to be sensed. <SIOF> is cleared to 0 when receiving has been completed. When it is confirmed that receiving has been completed, the last data is read. When <SIOINH> is set to 1, data receiving stops. <SIOF> is cleared to 0 (The received data becomes invalid, therefore no need to read it).

Note: When the transfer mode is changed, the contents of SBI0DBR will be lost. If the mode must be changed, conclude data receiving by clearing <SIOS> to 0, read the last data, then change the mode.

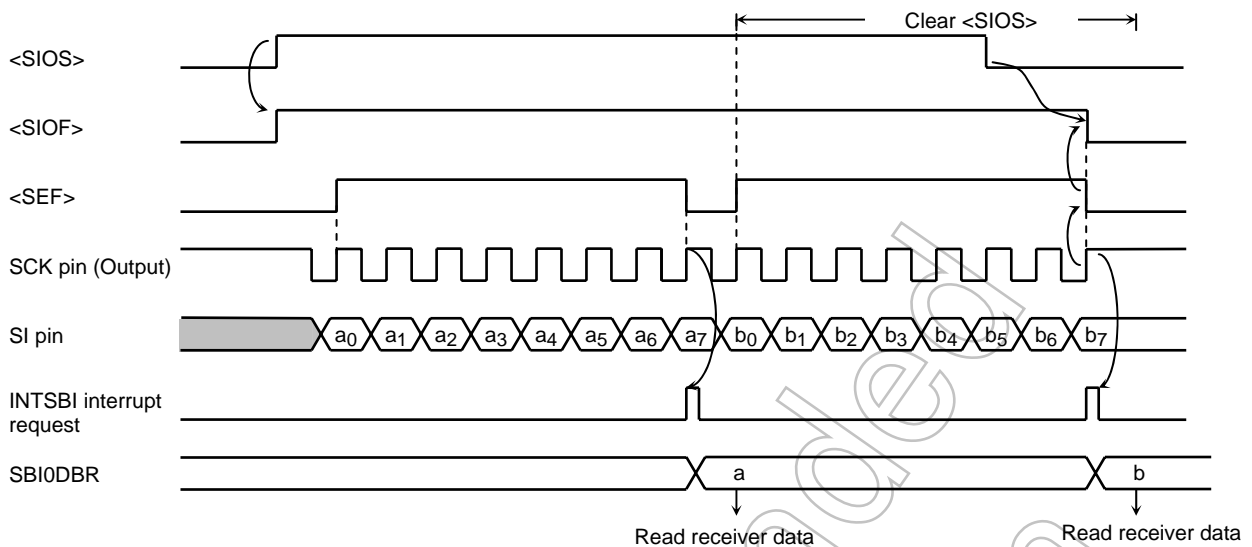

Figure 3.10.28 Receiver Mode (Example: Internal clock)

c. 8-bit transmit/receive mode

Set a control register to a transmit/receive mode and write data to SBI0DBR. After the data has been written, set SBI0CR<SIOS> to 1 to start transmitting/receiving. When data is transmitted, the data is output via the SO pin, starting from the least significant bit (LSB) and synchronized with the leading edge of the serial clock signal. When data is received, the data is input via the SI pin on the trailing edge of the serial clock signal. 8-bit data is transferred from the shift register to SBI0DBR and an INTSBI interrupt request is generated. The interrupt service program reads the received data from the data buffer register and writes the data which is to be transmitted. SBI0DBR is used for both transmitting and receiving. Transmitted data should always be written after received data has been read.

When an internal clock is used, the automatic wait function will be in effect until the received data has been read and the next data has been written.

When an external clock is used, since the shift operation is synchronized with the external clock, received data is read and transmitted data is written before a new shift operation is executed. The maximum transfer speed when an external clock is used is determined by the delay time between the time when an interrupt request is generated and the time at which received data is read and transmitted data is written.

When the transmit is started, after the SBI0SR<SIOF> goes 1 output from the SO pin holds final bit of the last data until falling edge of the SCK.

Transmitting/receiving data ends when <SIOS> is cleared to 0 by the INTS2 interrupt service program or when SBI0CR1<SIOINH> is set to 1. When <SIOS> is cleared to 0, received data is transferred to SBI0DBR in complete blocks. The transmit/receive mode ends when the transfer is complete. In order to confirm whether data is being transmitted/received properly by the program, set SBI0SR to be sensed. <SIOF> is set to 0 when transmitting/receiving has been completed. When <SIOINH> is set to 1, data transmitting/receiving stops. <SIOF> is then cleared to 0.

Note: When the transfer mode is changed, the contents of SBI0DBR will be lost. If the mode must be changed, conclude data transmitting/receiving by clearing <SIOS> to 0, read the last data, then change the transfer mode.

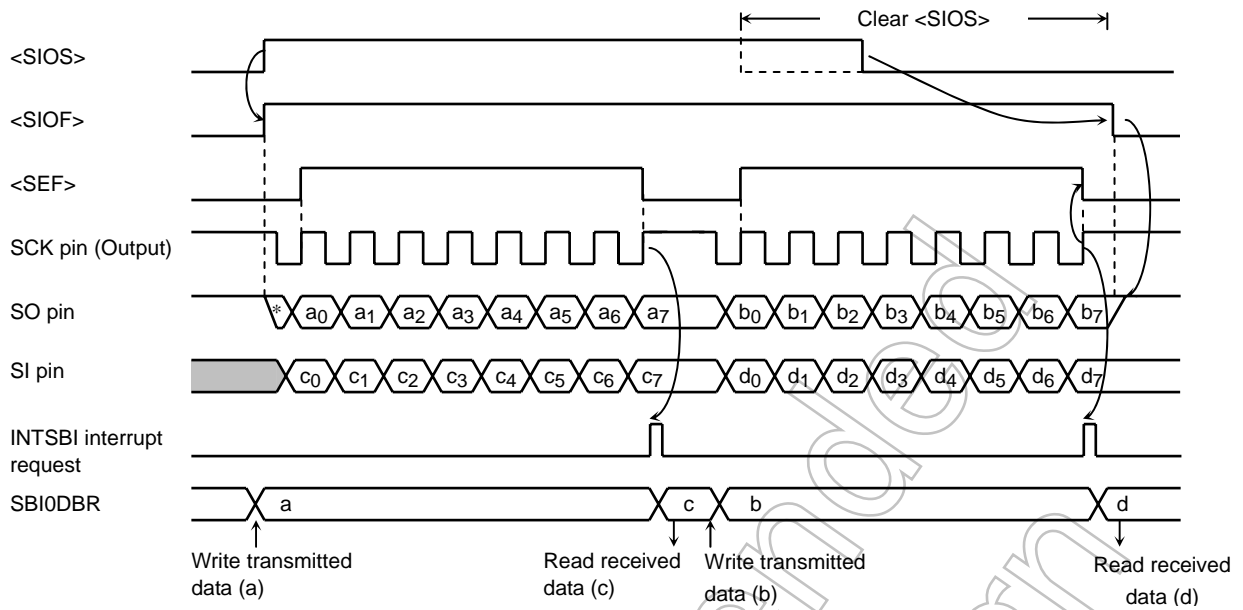

Figure 3.10.29 Transmit/Received Mode (Example using internal clock)

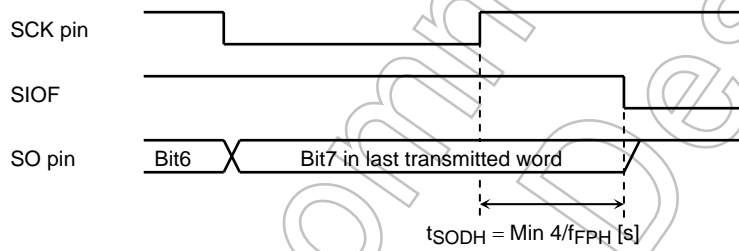

Figure 3.10.30 Transmitted Data Hold Time at End of Transmit/Receive

Not Recommended for New Design

3.11 Analog/Digital Converter

The TMP91FY42 incorporates a 10-bit successive approximation-type analog/digital converter (AD converter) with 8-channel analog input.

Figure 3.11.1 is a block diagram of the AD converter. The 8-channel analog input pins (AN0 to AN7) are shared with the input only port 5 and can thus be used as an input port.

Note: When IDLE2, IDLE1 or STOP mode is selected, so as to reduce the power, with some timings the system may enter a standby mode even though the internal comparator is still enabled. Therefore be sure to check that AD converter operations are halted before a HALT instruction is executed.

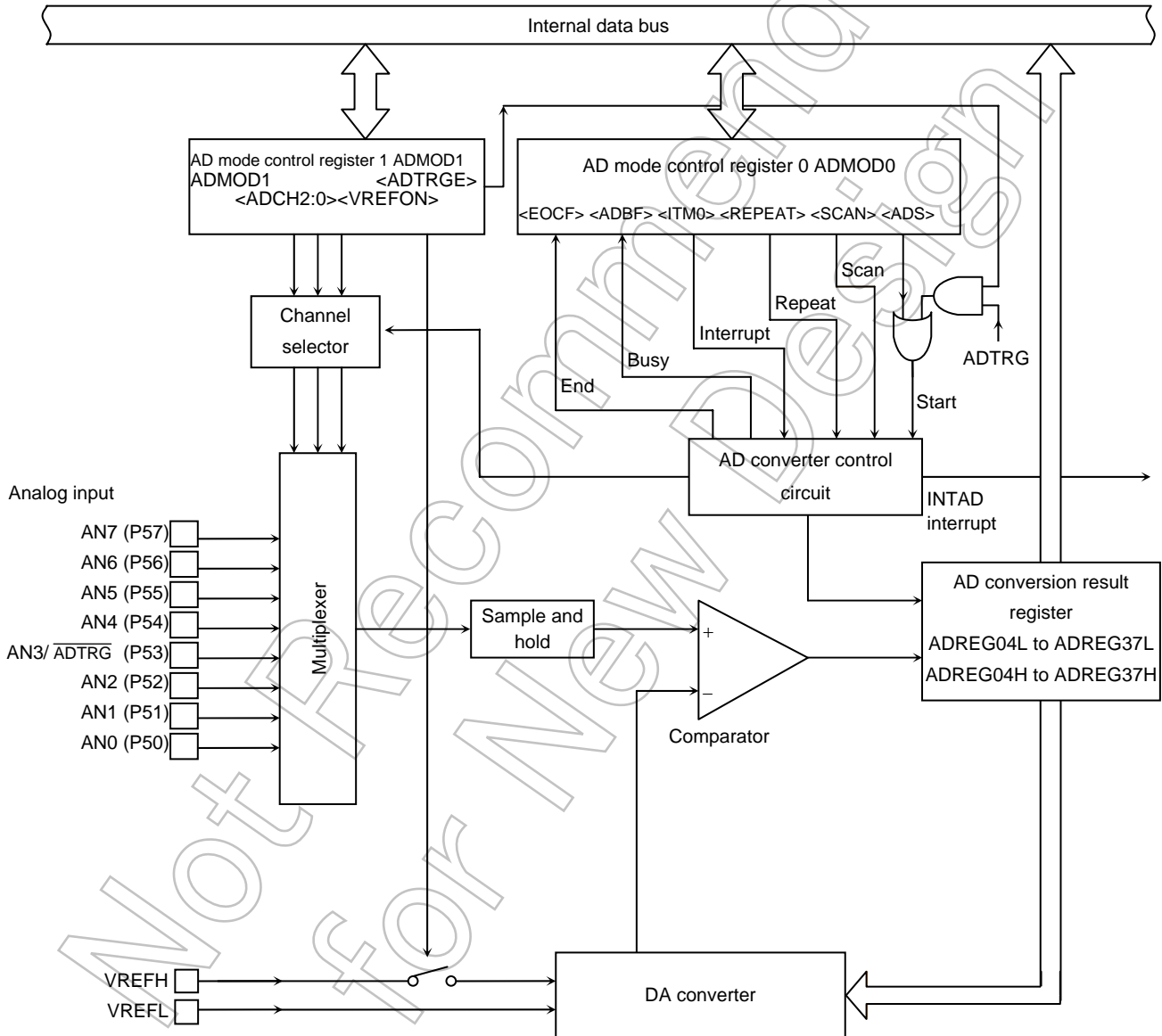

Figure 3.11.1 Block Diagram of AD Converter

3.11.1 Analog/Digital Converter Registers

The AD converter is controlled by the two AD mode control registers: ADMOD0 and ADMOD1. The AD conversion results are stored in 8 kinds of AD conversion data upper and lower registers: ADREG04H/L, ADREG15H/L, ADREG26H/L and ADREG37H/L.

Figure 3.11.2 shows the registers related to the AD converter.

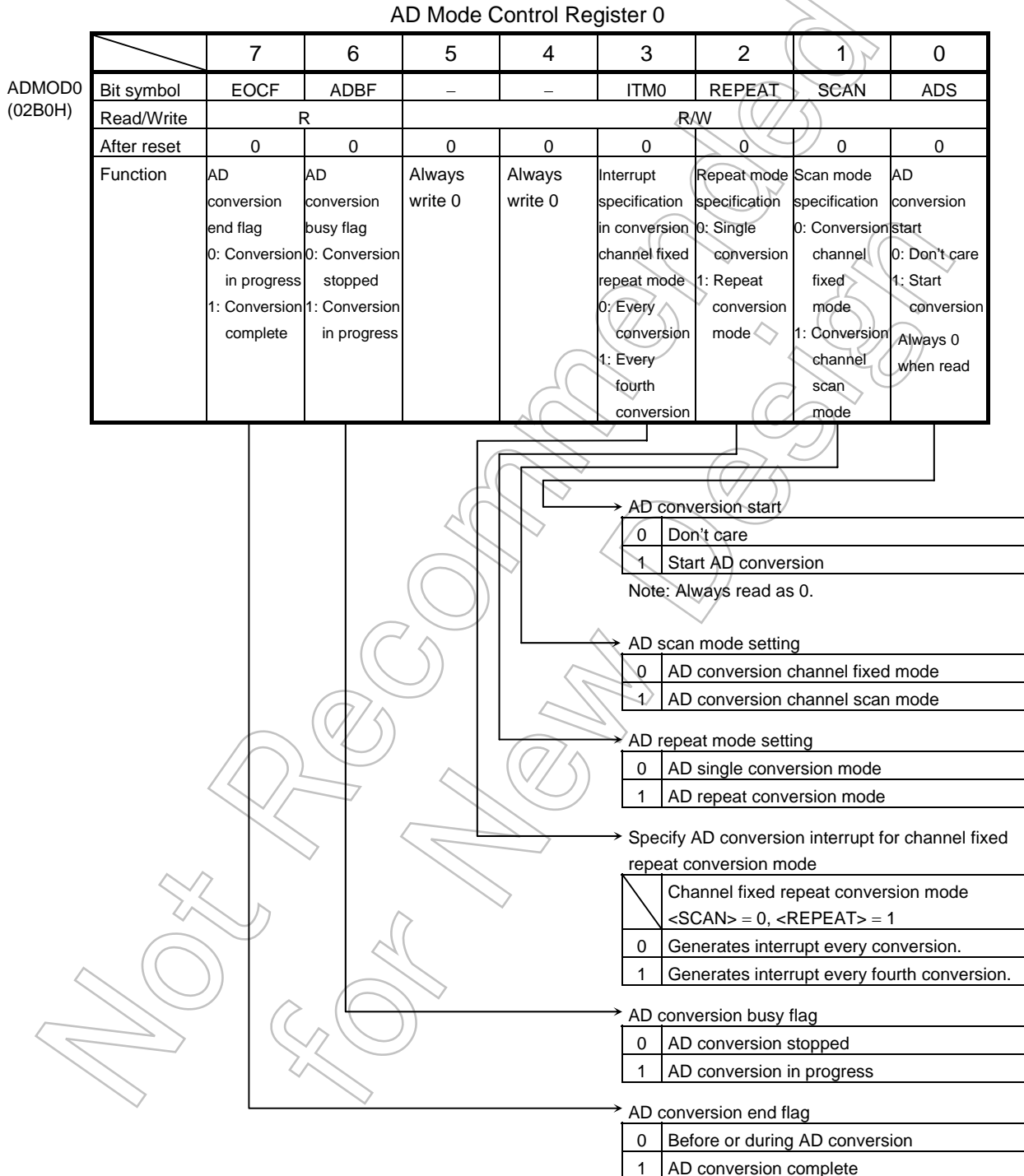

Figure 3.11.2 AD Converter Related Register

AD Mode Control Register 1

ADMOD1
(02B1H)

	7	6	5	4	3	2	1	0
Bit symbol	VREFON	IDLE2			ADTRGE	ADCH2	ADCH1	ADCH0
Read/Write	R/W				R/W			
After reset	0	0			0	0	0	0
Function	VREF application control 0: OFF 1: ON	IDLE2 0: Stop 1: Operate			AD external trigger start control 0: Disable 1: Enable	Analog input channel selection		

Analog input channel selection

	<SCAN>	0	1
		(Channel fixed)	(Channel scanned)
<ADCH2:0>			
000		AN0	AN0
001		AN1	AN0 → AN1
010		AN2	AN0 → AN1 → AN2
011 (Note)		AN3	AN0 → AN1 → AN2 → AN3
100		AN4	AN4
101		AN5	AN4 → AN5
110		AN6	AN4 → AN5 → AN6
111		AN7	AN4 → AN5 → AN6 → AN7

AD conversion start control by external trigger (ADTRG input)

0	Disabled
1	Enabled

IDLE2 control

0	Stopped
1	In operation

Control of application of reference voltage to AD converter

0	OFF
1	ON

Before starting conversion (before writing 1 to ADMOD0<ADS>), set the <VREFON> bit to 1.

Note: As pin AN3 also functions as the $\overline{\text{ADTRG}}$ input pin, do not set <ADCH2:0> = 011 when using $\overline{\text{ADTRG}}$ with <ADTRGE> = 0.

Figure 3.11.3 AD Converter Related Registers

AD Conversion Data Low Register 0/4

	7	6	5	4	3	2	1	0
ADREG04L (02A0H)	Bit symbol	ADR01	ADR00					ADR0RF
	Read/Write	R						R
	After reset	Undefined						0
	Function	Stores lower 2 bits of AD conversion result						AD conversion data storage flag 1: Conversion result stored

AD Conversion Data Upper Register 0/4

	7	6	5	4	3	2	1	0	
ADREG04H (02A1H)	Bit symbol	ADR09	ADR08	ADR07	ADR06	ADR05	ADR04	ADR03	ADR02
	Read/Write	R							
	After reset	Undefined							
	Function	Stores upper 8 bits AD conversion result.							

AD Conversion Data Lower Register 1/5

	7	6	5	4	3	2	1	0
ADREG15L (02A2H)	Bit symbol	ADR11	ADR10					ADR1RF
	Read/Write	R						R
	After reset	Undefined						0
	Function	Stores lower 2 bits of AD conversion result						AD conversion result flag 1: Conversion result stored

AD Conversion Data Upper Register 1/5

	7	6	5	4	3	2	1	0	
ADREG15H (02A3H)	Bit symbol	ADR19	ADR18	ADR17	ADR16	ADR15	ADR14	ADR13	ADR12
	Read/Write	R							
	After reset	Undefined							
	Function	Stores upper 8 bits of AD conversion result.							

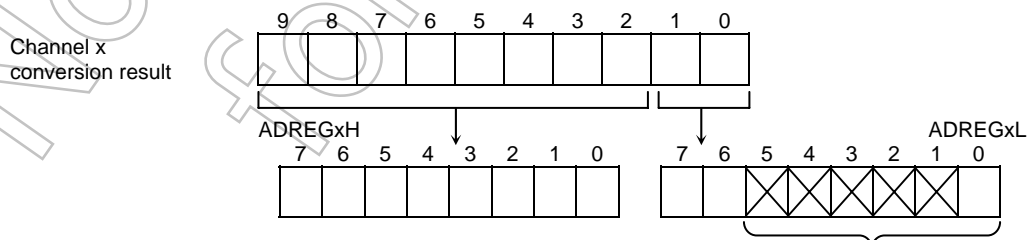

- Bits 5 to 1 are always read as 1.
- Bit0 is the AD conversion data storage flag <ADRxRF>. When the AD conversion result is stored, the flag is set to 1. When either of the registers (ADREGxH, ADREGxL) is read, the flag is cleared to 0.

Figure 3.11.4 AD Converter Related Registers

AD Conversion Result Lower Register 2/6

	7	6	5	4	3	2	1	0	
ADREG26L (02A4H)	Bit symbol	ADR21	ADR20					ADR2RF	
	Read/Write	R							R
	After reset	Undefined							0
	Function	Stores lower 2 bits of AD conversion result.							AD conversion data storage flag 1: Conversion result stored

AD Conversion Data upper Register 2/6

	7	6	5	4	3	2	1	0	
ADREG26H (02A5H)	Bit symbol	ADR29	ADR28	ADR27	ADR26	ADR25	ADR24	ADR23	ADR22
	Read/Write	R							
	After reset	Undefined							
	Function	Stores upper 8 bits of AD conversion result.							

AD Conversion Data Lower Register 3/7

	7	6	5	4	3	2	1	0	
ADREG37L (02A6H)	Bit symbol	ADR31	ADR30					ADR3RF	
	Read/Write	R							R
	After reset	Undefined							0
	Function	Stores lower 2 bits of AD conversion result.							AD Conversion Data Storage flag 1: conversion result stored

AD Conversion Result Upper Register 3/7

	7	6	5	4	3	2	1	0	
ADREG37H (02A7H)	Bit symbol	ADR39	ADR38	ADR37	ADR36	ADR35	ADR34	ADR33	ADR32
	Read/Write	R							
	After reset	Undefined							
	Function	Stores upper 8 bits of AD conversion result.							

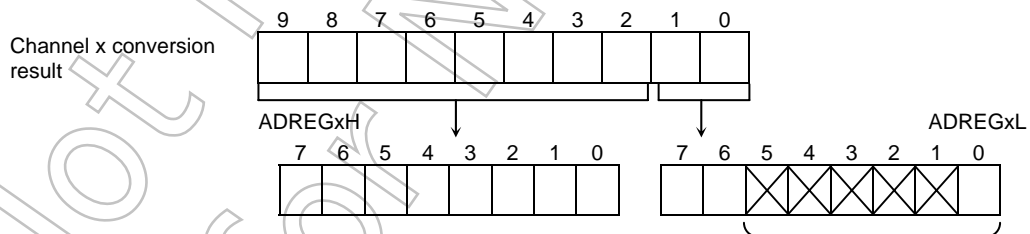

- Bits 5 to 1 are always read as 1.
- Bit0 is the AD conversion data storage flag <ADRxRF>. When the AD conversion result is stored, the flag is set to 1. When either of the registers (ADREGxH, ADREGxL) is read, the flag is cleared to 0.

Figure 3.11.5 AD Converter Related Registers

3.11.2 Description of Operation

(1) Analog reference voltage

A high-level analog reference voltage is applied to the VREFH pin; a low-level analog reference voltage is applied to the VREFL pin. To perform AD conversion, the reference voltage as the difference between VREFH and VREFL, is divided by 1024 using string resistance. The result of the division is then compared with the analog input voltage.

To turn off the switch between VREFH and VREFL, write 0 to ADMOD1<VREFON> in AD mode control register 1. To start AD conversion in the off state, first write 1 to ADMOD1<VREFON>, wait 3 μ s until the internal reference voltage stabilizes (This is not related to f_c), then set ADMOD0<ADS> to 1.

(2) Analog input channel selection

The analog input channel selection varies depends on the operation mode of the AD converter.

- In analog input channel fixed mode (ADMOD0<SCAN> = 0)

Setting ADMOD1<ADCH2:0> selects one of the input pins AN0 to AN7 as the input channel.

- In analog input channel scan mode (ADMOD0<SCAN> = 1)

Setting ADMOD1<ADCH2:0> selects one of the 8 scan modes.

Table 3.11.1 illustrates analog input channel selection in each operation mode.

After reset, ADMOD0<SCAN> = 0 and ADMOD1<ADCH2:0> = 000. Thus pin AN0 is selected as the fixed input channel. Pins not used as analog input channels can be used as standard input port pins.

Table 3.11.1 Analog Input Channel Selection

<ADCH2:0>	Channel Fixed <SCAN> = 0	Channel Scan <SCAN> = 1
000	AN0	AN0
001	AN1	AN0 → AN1
010	AN2	AN0 → AN1 → AN2
011	AN3	AN0 → AN1 → AN2 → AN3
100	AN4	AN4
101	AN5	AN4 → AN5
110	AN6	AN4 → AN5 → AN6
111	AN7	AN4 → AN5 → AN6 → AN7

(3) Starting AD conversion

To start AD conversion, write 1 to ADMOD0<ADS> in AD mode control register 0, or ADMOD1<ADTRGE> in AD mode control register 1 and input falling edge on $\overline{\text{ADTRG}}$ pin. When AD conversion starts, the AD conversion busy flag ADMOD0<ADBF> will be set to 1, indicating that AD conversion is in progress.

Writing 1 to ADMOD0<ADS> during AD conversion restarts conversion. At that time, to determine whether the AD conversion results have been preserved, check the value of the conversion data storage flag ADREGxL<ADR_xRF>.

During AD conversion, a falling edge input on the $\overline{\text{ADTRG}}$ pin will be ignored.

(4) AD conversion modes and the AD conversion end interrupt

The 4 AD conversion modes are:

- Channel fixed single conversion mode
- Channel scan single conversion mode
- Channel fixed repeat conversion mode
- Channel scan repeat conversion mode

The ADMOD0<REPEAT> and ADMOD0<SCAN> settings in AD mode control register 0 determine the AD mode setting.

Completion of AD conversion triggers an INTAD AD conversion end interrupt request. Also, ADMOD0<EOCF> will be set to 1 to indicate that AD conversion has been completed.

a. Channel fixed single conversion mode

Setting ADMOD0<REPEAT> and ADMOD0<SCAN> to 00 selects channel fixed single conversion mode.

In this mode, data on one specified channel is converted once only. When the conversion has been completed, the ADMOD0<EOCF> flag is set to 1, ADMOD0<ADBF> is cleared to 0, and an INTAD interrupt request is generated.

b. Channel scan single conversion mode

Setting ADMOD0<REPEAT> and ADMOD0<SCAN> to 01 selects channel scan single conversion mode.

In this mode, data on the specified scan channels is converted once only. When scan conversion has been completed, ADMOD0<EOCF> is set to 1, ADMOD0<ADBF> is cleared to 0, and an INTAD interrupt request is generated.

c. Channel fixed repeat conversion mode

Setting ADMOD0<REPEAT> and ADMOD0<SCAN> to 10 selects channel fixed repeat conversion mode.

In this mode, data on one specified channel is converted repeatedly. When conversion has been completed, ADMOD0<EOCF> is set to 1 and ADMOD0<ADBF> is not cleared to 0 but held 1. INTAD interrupt request generation timing is determined by the setting of ADMOD0<ITM0>.

Setting <ITM0> to 0 generates an interrupt request every time an AD conversion is completed.

Setting <ITM0> to 1 generates an interrupt request on completion of every fourth conversion.

d. Channel scan repeat conversion mode

Setting ADMOD0<REPEAT> and ADMOD0<SCAN> to 11 selects channel scan repeat conversion mode.

In this mode, data on the specified scan channels is converted repeatedly. When each scan conversion has been completed, ADMOD0<EOCF> is set to 1 and an INTAD interrupt request is generated. ADMOD0<ADBF> is not cleared to 0 but held 1.

To stop conversion in a repeat conversion mode (e.g., in cases c. and d.), write a 0 to ADMOD0<REPEAT>. After the current conversion has been completed, the repeat conversion mode terminates and ADMOD0<ADBF> is cleared to 0.

Switching to a halt state (IDLE2 mode with ADMOD1<I2AD> cleared to 0, IDLE1 mode or STOP mode) immediately stops operation of the AD converter even when AD conversion is still in progress. In repeat conversion modes (e.g., in cases c. and d.), when the halt is released, conversion restarts from the beginning. In single conversion modes (e.g., in cases a. and b.), conversion does not restart when the halt is released (The converter remains stopped).

Table 3.11.2 shows the relationship between the AD conversion modes and interrupt requests.

Table 3.11.2 Relationship between AD Conversion Modes and Interrupt Requests

Mode	Interrupt Request Generation	ADMOD0		
		<ITM0>	<REPEAT>	<SCAN>
Channel fixed single conversion mode	After completion of conversion	X	0	0
Channel scan single conversion mode	After completion of scan conversion	X	0	1
Channel fixed repeat conversion mode	Every conversion	0	1	0
	Every forth conversion	1		
Channel scan repeat conversion mode	After completion of every scan conversion	X	1	1

X: Don't care

(5) AD conversion time

84 states (6.2 μ s at $f_{\text{FPH}} = 27$ MHz) are required for the AD conversion for one channel.

(6) Storing and reading the results of AD conversion

The AD conversion data upper and lower registers (ADREG04H/L to ADREG37H/L) store the AD conversion results. (ADREG04H/L to ADREG37H/L are read-only registers.)

In channel fixed repeat conversion mode, the conversion results are stored successively in registers ADREG04H/L to ADREG37H/L. In other modes, the AN0 and AN4, AN1 and AN5, AN2 and AN6, and AN3 and AN7 conversion results are stored in ADREG04H/L, ADREG15H/L, ADREG26H/L and ADREG37H/L respectively.

Table 3.11.3 shows the correspondence between the analog input channels and the registers which are used to hold the results of AD conversion.

Table 3.11.3 Correspondence between Analog Input Channels and AD Conversion Result Registers

Analog Input Channel (Port 8)	AD Conversion Result Register	
	Conversion Modes Other than at Right	Channel Fixed Repeat Conversion Mode (<ITM0> = 1)
AN0	ADREG04H/L	ADREG04H/L ←
AN1	ADREG15H/L	↓
AN2	ADREG26H/L	ADREG15H/L
AN3	ADREG37H/L	↓
AN4	ADREG04H/L	ADREG26H/L
AN5	ADREG15H/L	↓
AN6	ADREG26H/L	ADREG37H/L
AN7	ADREG37H/L	←

<ADR_xRF>, bit0 of the AD conversion data lower register, is used as the AD conversion data storage flag. The storage flag indicates whether the AD conversion result register has been read or not. When a conversion result is stored in the AD conversion result register, the flag is set to 1. When either of the AD conversion result registers (ADREG_xH or ADREG_xL) is read, the flag is cleared to 0.

Reading the AD conversion result also clears the AD conversion end flag ADMOD0<EOCF> to 0.

Example:

- a. Convert the analog input voltage on the AN3 pin and write the result, to memory address 0800H using the AD interrupt (INTAD) processing routine.

Main routine:

	7 6 5 4 3 2 1 0	
INTE0AD	← - 1 0 0 - - -	Enable INTAD and set it to interrupt level 4.
ADMOD1	← 1 1 X X 0 0 1 1	Set pin AN3 to be the analog input channel.
ADMOD0	← - - 0 0 X 0 0 1	Start conversion in channel fixed single conversion mode.

Interrupt routine processing example:

WA	← ADREG37	Read value of ADREG37L and ADREG37H into 16-bit general-purpose register WA.
WA	>> 6	Shift contents read into WA six times to right and zero-fill upper bits.
(0800H)	← WA	Write contents of WA to memory address 0800H.

- b. This example repeatedly converts the analog input voltages on the three pins AN0, AN1 and AN2, using channel scan repeat conversion mode.

INTE0AD	← - 0 0 0 - - -	Disable INTAD.
ADMOD1	← 1 - X X 0 0 1 0	Set pins AN0 to AN2 to be the analog input channels.
ADMOD0	← - - 0 0 X 1 1 1	Start conversion in channel scan repeat conversion mode.

X: Don't care; -: No change

3.12 Watchdog Timer (Runaway detection timer)

The TMP91FY42 features a watchdog timer for detecting runaway.

The watchdog timer (WDT) is used to return the CPU to normal state when it detects that the CPU has started to malfunction (Runaway) due to causes such as noise.

When the watchdog timer detects a malfunction, it generates a non-maskable interrupt INTWD to notify the CPU. Connecting the watchdog timer output to the reset pin internally forces a reset. (The level of external $\overline{\text{RESET}}$ pin is not changed)

3.12.1 Configuration

Figure 3.12.1 is a block diagram of the watchdog timer (WDT).

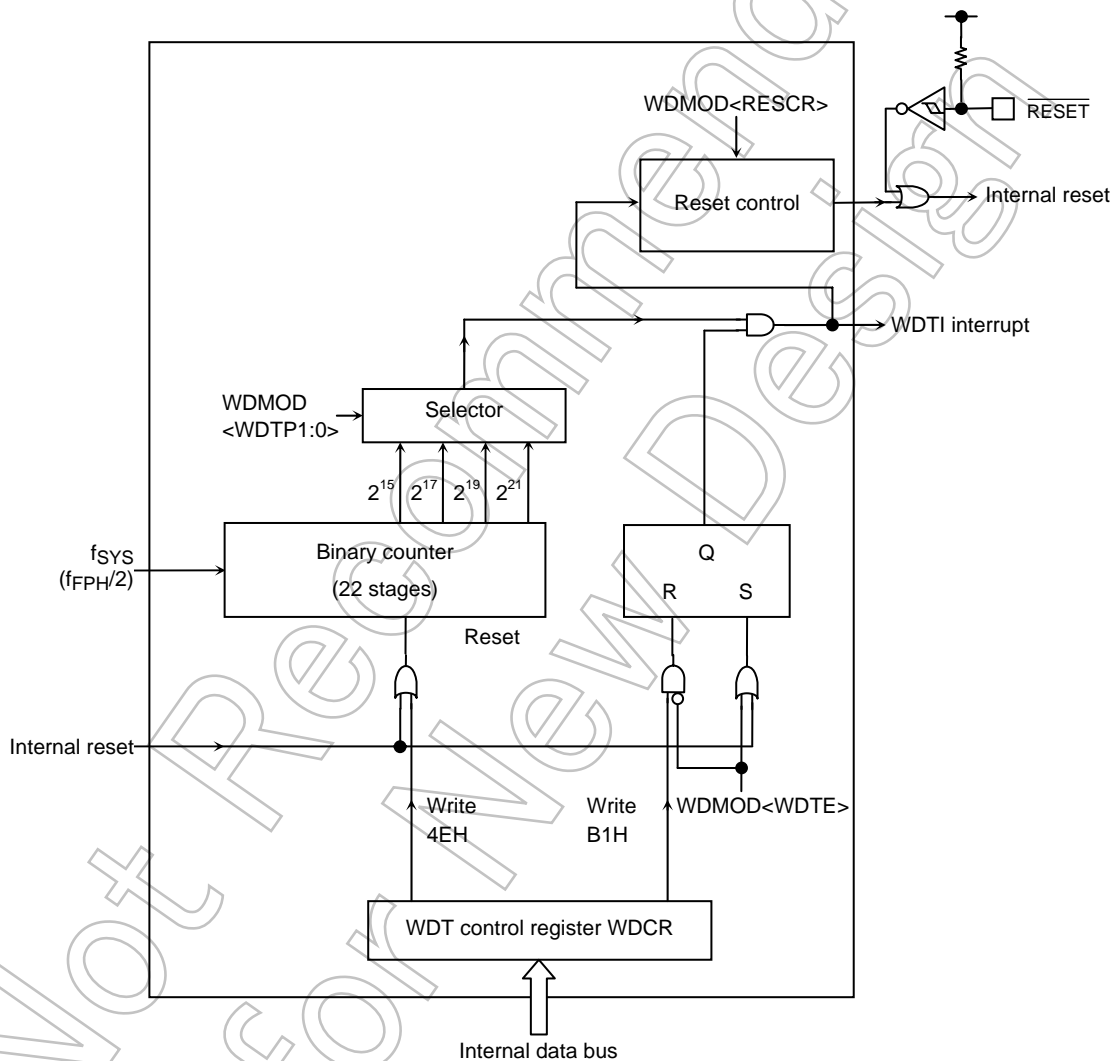

Figure 3.12.1 Block Diagram of Watchdog Timer

Note: Care must be exercised in the overall design of the apparatus since the watchdog timer may fail to function correctly due to external noise, etc.

3.12.2 Operation

The watchdog timer generates an INTWD interrupt when the detection time set in the WDMOD<WDTP1:0> has elapsed. The watchdog timer must be cleared 0 by software before an INTWD interrupt will be generated. If the CPU malfunctions (e.g., if runaway occurs) due to causes such as noise, but does not execute the instruction used to clear the binary counter, the binary counter will overflow and an INTWD interrupt will be generated. The CPU will detect malfunction (Runaway) due to the INTWD interrupt and in this case it is possible to return to the CPU to normal operation by means of an anti-malfunction program.

The watchdog timer works immediately after reset.

The watchdog timer does not operate in IDLE1 or STOP mode, as the binary counter continues counting during bus release (when $\overline{\text{BUSAK}}$ goes low).

When the device is in IDLE2 mode, the operation of WDT depends on the WDMOD<I2WDT> setting. Ensure that WDMOD<I2WDT> is set before the device enters IDLE2 mode.

The watchdog timer consists of a 22-stage binary counter which uses the system clock (f_{SYS}) as the input clock. The binary counter can output $f_{\text{SYS}}/2^{15}$, $f_{\text{SYS}}/2^{17}$, $f_{\text{SYS}}/2^{19}$ and $f_{\text{SYS}}/2^{21}$.

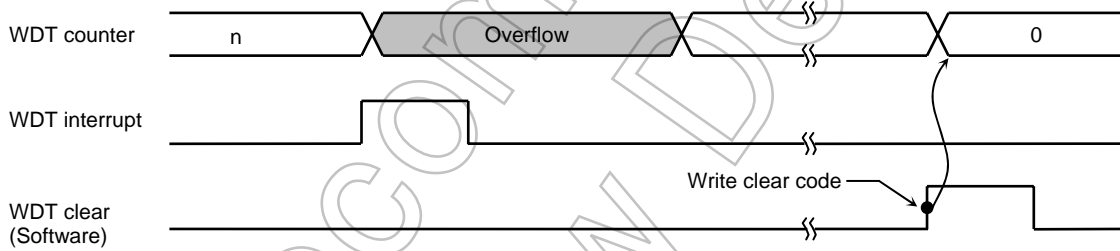

Figure 3.12.2 NORMAL Mode

The runaway is detected when an overflow occurs, and the watchdog timer can reset device. In this case, the reset time will be between 22 and 29 states ($26.1 \sim 34.4 \mu\text{s}$ at $f_{\text{OSCH}} = 27\text{MHz}$, $f_{\text{FPH}} = 1.7 \text{ MHz}$) is $f_{\text{FPH}}/2$, where f_{FPH} is generated by dividing the high-speed oscillator clock (f_{OSCH}) by sixteen through the clock gear function.

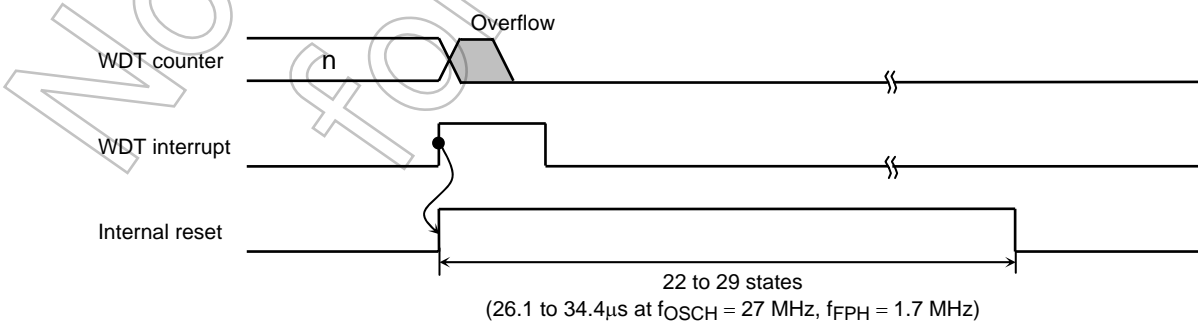

Figure 3.12.3 Reset Mode

3.12.3 Control Registers

The watchdog timer WDT is controlled by two control registers WDMOD and WDCR.

(1) Watchdog timer mode register (WDMOD)

- a. Setting the detection time for the watchdog timer in <WDTP1:0>

This 2-bit register is used for setting the watchdog timer interrupt time used when detecting runaway. After reset, this register is initialized to WDMOD<WDTP1:0> = 00.

The detection times for WDT are shown in Figure 3.12.4.

- b. Watchdog timer enable/disable control register <WDTE>

After reset, WDMOD<WDTE> is initialized to 1, enabling the watchdog timer. To disable the watchdog timer, it is necessary to set this bit to 0 and to write the disable code (B1H) to the watchdog timer control register WDCR. This makes it difficult for the watchdog timer to be disabled by runaway.

However, it is possible to return the watchdog timer from the disabled state to the enabled state merely by setting <WDTE> to 1.

- c. Watchdog timer out reset connection <RESCR>

This register is used to connect the output of the watchdog timer with the RESET terminal internally. Since WDMOD<RESCR> is initialized to 0 on reset, a reset by the watchdog timer will not be performed.

(2) Watchdog timer control register (WDCR)

This register is used to disable and clear the binary counter for the watchdog timer.

Disable control the watchdog timer can be disabled by clearing WDMOD<WDTE> to 0 and then writing the disable code (B1H) to the WDCR register.

WDCR	← 0 1 0 0 1 1 1 0	Write the clear code (4EH).
WDMOD	← 0 - - X X - - -	Clear WDMOD<WDTE> to 0.
WDCR	← 1 0 1 1 0 0 0 1	Write the disable code (B1H).

- Enable control

Set WDMOD<WDTE> to 1.

- Watchdog timer clear control

To clear the binary counter and cause counting to resume, write the clear code (4EH) to the WDCR register.

WDCR	← 0 1 0 0 1 1 1 0	Write the clear code (4EH).
------	-------------------	-----------------------------

Note1: If the disable control is used, set the disable code (B1H) to WDCR after writing the clear code (4EH) once.

(Please refer to setting example.)

Note2: If the watchdog timer setting is changed, change setting after setting to disable condition once.

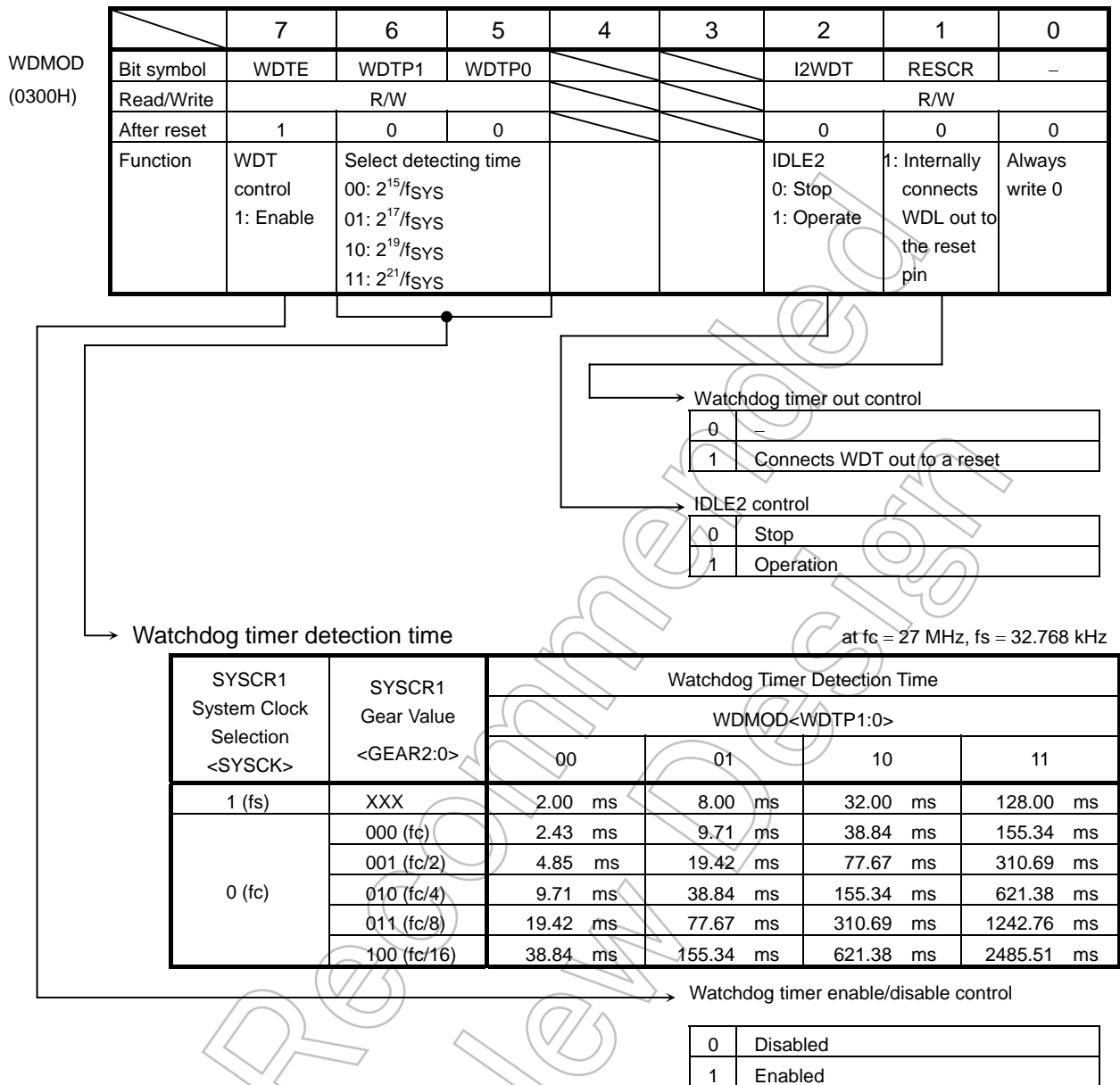

Figure 3.12.4 Watchdog Timer Mode Register

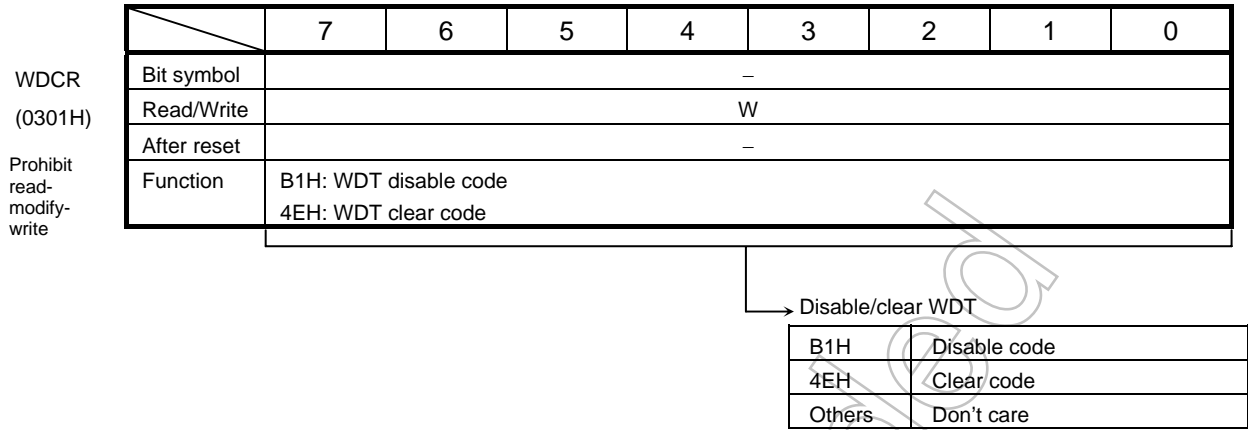

Figure 3.12.5 Watchdog Timer Control Register

Not Recommended for New Design

3.13 Special timer for CLOCK

The TMP91FY42 includes a timer that is used for a clock operation.

An interrupt (INTRTC) can be generated each 0.0625 [s] or 0.125 [s] or 0.25 [s] or 0.50 [s] by using a low frequency clock of 32.768 kHz. A clock function can be easily used.

Special timer for CLOCK can operate in all modes in which a low-frequency oscillation is operated.

In addition, INTRTC can return from each standby mode except STOP mode.

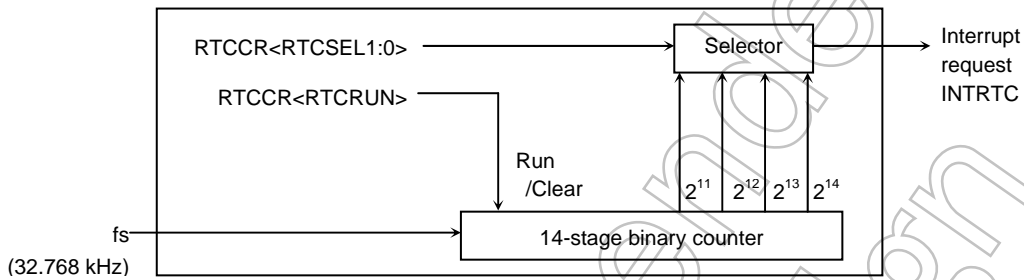

Figure 3.13.1 Block Diagram for Special timer for CLOCK

The Special timer for CLOCK is controlled by the Special timer for CLOCK control register (RTCCR) as shown in .

	7	6	5	4	3	2	1	0	
Bit symbol	-				RTCSEL1			RTCSEL0	RTC RUN
Read/Write	R/W				R/W				
After reset	0				0			0	0
Function	Always write "0".				00: $2^{14}/f_s$ 01: $2^{13}/f_s$ 10: $2^{12}/f_s$ 11: $2^{11}/f_s$			0: Stop & clear	1: Count

Counting operation	
0	Stop & clear
1	Count

Interrupt generation cycle ($f_s = 32.768 \text{ kHz}$)	
00	0.50 s
01	0.25 s
10	0.125 s
11	0.0625 s

Figure 3.13.2 Special timer for CLOCK Control Register

3.14 Flash Memory

The TMP91FY42 incorporates flash memory that can be electrically erased and programmed using a single 3V power supply.

The flash memory is programmed and erased using JEDEC-standard commands. After a program or erase command is input, the corresponding operation is automatically performed internally. Erase operations can be performed by the entire chip (chip erase) or on a sector basis (sector erase).

The configuration and operations of the flash memory are described below.

3.14.1 Features

- Power supply voltage for program/erase operations
Vcc = 3.0 V to 3.6 V (-10 °C to 40 °C)
- Configuration
128 K × 16 bits (256 Kbytes)
- Functions
Single-word programming
Chip erase
Sector erase
Data polling/Toggle bit
- Sector size
4 Kbytes × 64
- Mode control
JEDEC-standard commands
- Programming method
On-board programming
Parallel programmer
- Security
Write protection
Read protection

3.14.2 Block Diagram

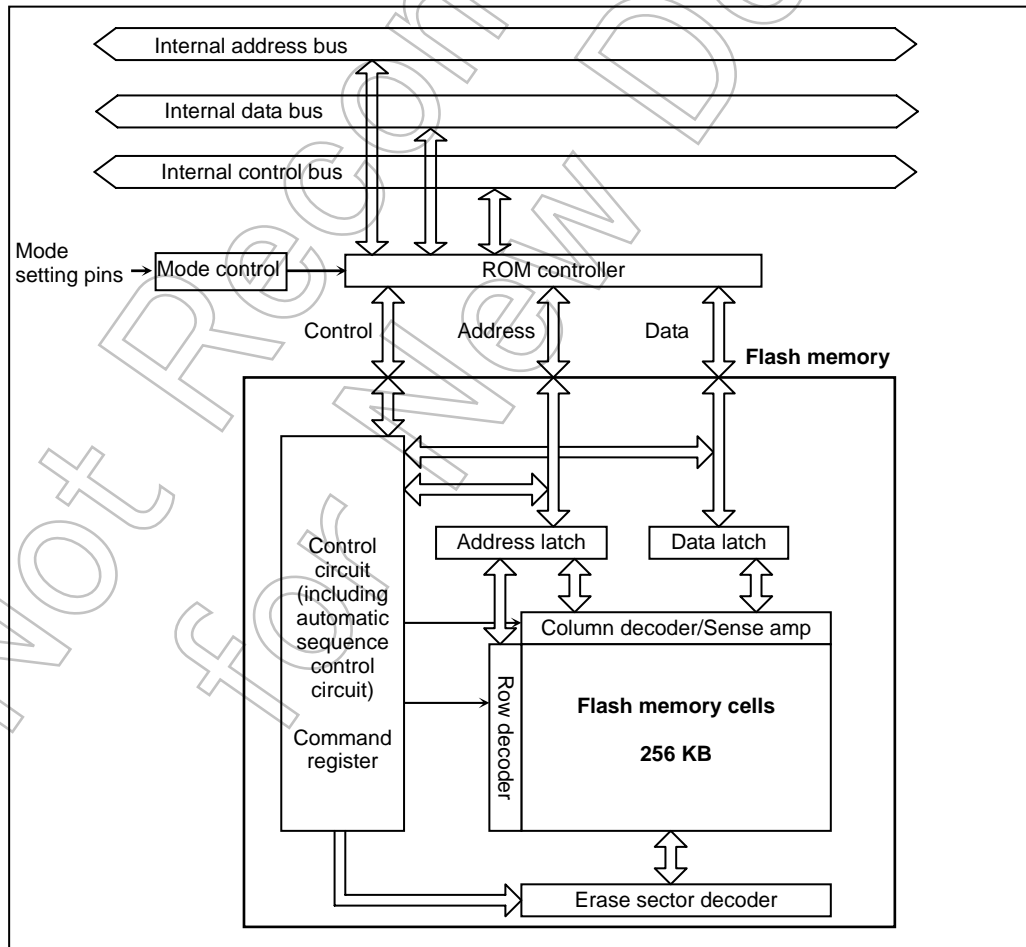

Figure 3.14.1 Block Diagram of Flash Memory Unit

3.14.3 Operation Modes

3.14.3.1 Overview

The following three types of operation modes are available to control program/erase operations on the flash memory.

Table 3.14.1 Description of Operation Modes

Operation Mode Name	Description
Single Chip mode	After reset release, the device starts up from the internal flash memory. Single Chip mode is further divided into two modes: "Normal mode" is a mode in which user application programs are executed, and "User Boot mode" is used to program the flash memory on-board. The means of switching between these two modes can be set by the user as desired. For example, it can be set so that Port 00 = '1' selects Normal mode and Port 00 = '0' selects User Boot mode. The user must include a routine to handle mode switching in a user application program.
Normal mode	In this mode, the device starts up from a user application program.
User Boot mode	In this mode, the flash memory can be programmed by a user-specified method.
Single Boot mode	After reset release, the device starts up from the internal boot ROM (mask ROM). The boot ROM includes an algorithm which allows a program for programming/erasing the flash memory on-board via a serial port to be transferred to the device's internal RAM. The transferred program is then executed in the internal RAM so that the flash memory can be programmed/erased by receiving data from an external host and issuing program/erase commands.
Programmer mode	This mode enables the internal flash memory to be programmed/erased using a general-purpose programmer. For programmers that can be used, please contact your local Toshiba sales representative.

Of the modes listed in Table 3.14.1, the internal flash memory can be programmed in User Boot mode, Single Boot mode and Programmer mode.

The mode in which the flash memory can be programmed/erased while mounted on the user board is defined as the on-board programming mode. Of the modes listed above, Single Boot mode and User Boot mode are classified as on-board programming modes. Single Boot mode supports Toshiba's proprietary programming/erase method using serial I/O. User Boot mode (within Single Chip mode) allows the flash memory to be programmed/erased by a user-specified method.

Programmer mode is provided with a read protect function which prohibits reading of ROM data. By enabling the read protect function upon completion of programming, the user can protect ROM data from being read by third parties.

The operation mode — Single Chip mode, Single Boot mode or Programmer mode — is determined during reset by externally setting the input levels on the AM0, AM1 and $\overline{\text{BOOT}}$ (P37) pins.

Except in Programmer mode which is entered with $\overline{\text{RESET}}$ held at “0”, the CPU will start operating in the selected mode after the reset state is released. Once the operation mode has been set, make sure that the input levels on the mode setting pins are not changed during operation. Table 3.14.2 shows how to set each operation mode, and Figure 3.14.2 shows a mode transition diagram.

Table 3.14.2 Operation Mode Pin Settings

	Operation Mode	Input Pins			
		RESET	BOOT (P37)	AM1	AM0
(1)	Single Chip mode (Normal or User Boot mode)		1	1	1
(2)	Single Boot mode	—	0	1	1
(3)	Programmer mode	0	—	1	0

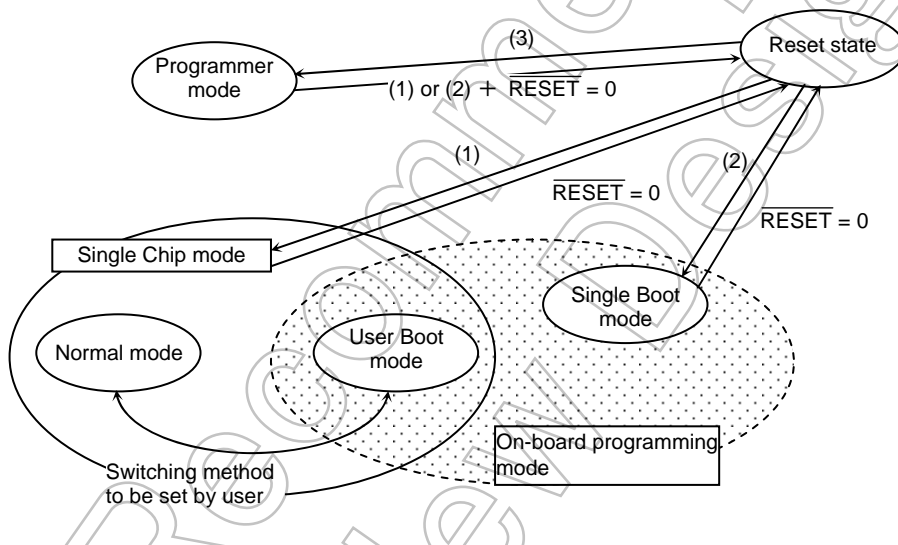

Numbers in () correspond to the operation mode pin settings shown in Table 3.14.2.

Figure 3.14.2 Mode Transition Diagram

3.14.3.2 Reset Operation

To reset the device, hold the $\overline{\text{RESET}}$ input at “0” for at least 10 system clocks while the power supply voltage is within the rated operating voltage range and the internal high-frequency oscillator is oscillating stably. For details, refer to 3.1.1 “Reset Operation.”

3.14.3.3 Memory Map for Each Operation Mode

In this product, the memory map varies with operation mode. The memory map and sector address ranges for each operation mode are shown below.

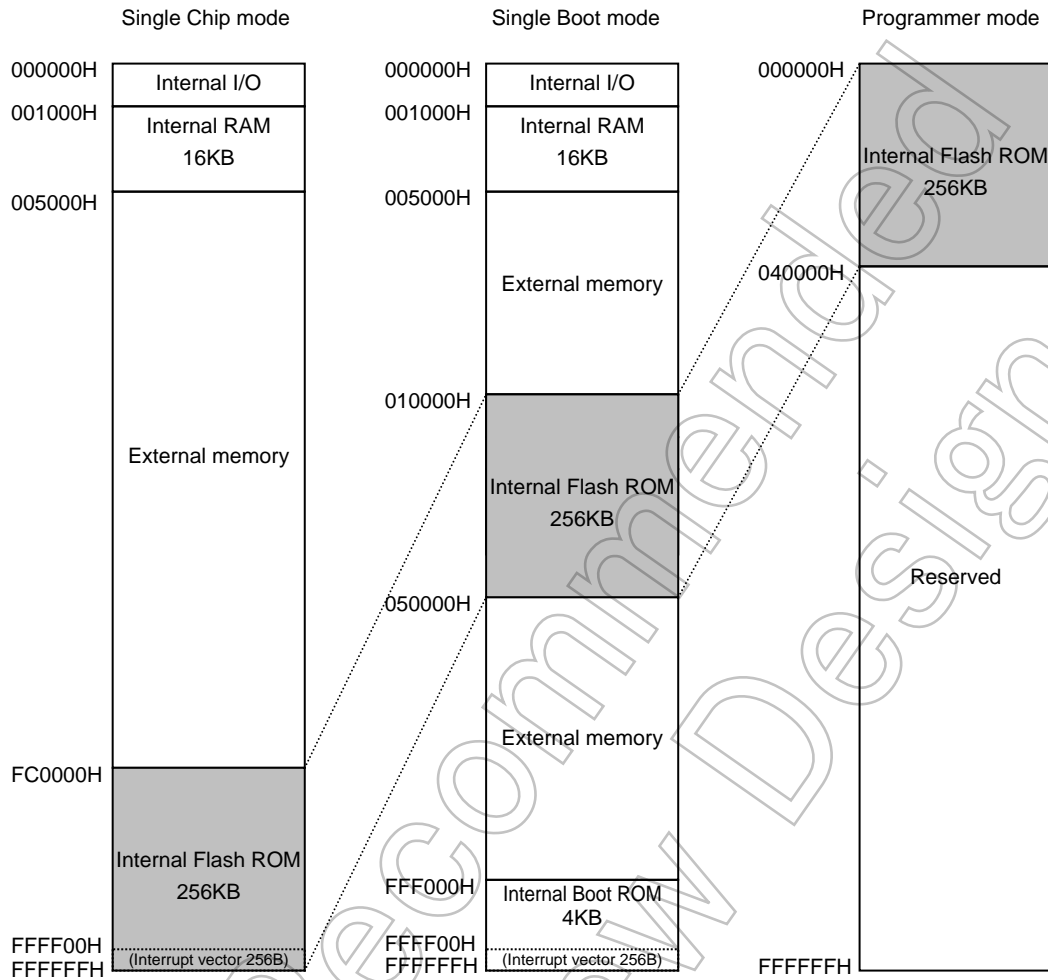

Figure 3.14.3 TMP91FY42 Memory Map for Each Operation Mode

Not Recommended for New Design

Table 3.14.3 Sector Address Ranges for Each Operation Mode

	Single Chip Mode	Single Boot Mode
Sector-0	FC0000H to FC0FFFH	10000H to 10FFFFH
Sector-1	FC1000H to FC1FFFH	11000H to 11FFFFH
Sector-2	FC2000H to FC2FFFH	12000H to 12FFFFH
Sector-3	FC3000H to FC3FFFH	13000H to 13FFFFH
Sector-4	FC4000H to FC4FFFH	14000H to 14FFFFH
Sector-5	FC5000H to FC5FFFH	15000H to 15FFFFH
Sector-6	FC6000H to FC6FFFH	16000H to 16FFFFH
Sector-7	FC7000H to FC7FFFH	17000H to 17FFFFH
Sector-8	FC8000H to FC8FFFH	18000H to 18FFFFH
Sector-9	FC9000H to FC9FFFH	19000H to 19FFFFH
Sector-10	FCA000H to FCAFFFH	1A000H to 1AFFFFH
Sector-11	FCB000H to FCBFFFH	1B000H to 1BFFFFH
Sector-12	FCC000H to FCCFFFH	1C000H to 1CFFFFH
Sector-13	FCD000H to FCDFFFH	1D000H to 1DFFFFH
Sector-14	FCE000H to FCEFFFH	1E000H to 1EFFFFH
Sector-15	FCF000H to FCFFFFH	1F000H to 1FFFFFH
Sector-16	FD0000H to FD0FFFH	20000H to 20FFFFH
.	.	.
.	.	.
.	.	.
.	.	.
Sector-47	FEF000H to FFFFFFFH	3F000H to 3FFFFFFH
Sector-48	FF0000H to FF0FFFH	40000H to 40FFFFH
Sector-49	FF1000H to FF1FFFH	41000H to 41FFFFH
Sector-50	FF2000H to FF2FFFH	42000H to 42FFFFH
Sector-51	FF3000H to FF3FFFH	43000H to 43FFFFH
Sector-52	FF4000H to FF4FFFH	44000H to 44FFFFH
Sector-53	FF5000H to FF5FFFH	45000H to 45FFFFH
Sector-54	FF6000H to FF6FFFH	46000H to 46FFFFH
Sector-55	FF7000H to FF7FFFH	47000H to 47FFFFH
Sector-56	FF8000H to FF8FFFH	48000H to 48FFFFH
Sector-57	FF9000H to FF9FFFH	49000H to 49FFFFH
Sector-58	FFA000H to FFAFFFH	4A000H to 4AFFFFH
Sector-59	FFB000H to FFBFFFH	4B000H to 4BFFFFH
Sector-60	FFC000H to FFCFFFH	4C000H to 4CFFFFH
Sector-61	FFD000H to FFDFFFH	4D000H to 4DFFFFH
Sector-62	FFE000H to FFEFFFH	4E000H to 4EFFFFH
Sector-63	FFF000H to FFFFFFFH	4F000H to 4FFFFFFH

3.14.4 Single Boot Mode

In Single Boot mode, the internal boot ROM (mask ROM) is activated to transfer a program/erase routine (user-created boot program) from an external source into the internal RAM. This program/erase routine is then used to program/erase the flash memory. In this mode, the internal boot ROM is mapped into an area containing the interrupt vector table, in which the boot ROM program is executed. The flash memory is mapped into an address space different from the one into which the boot ROM is mapped (see Figure 3.14.3).

The device's SIO (SIO1) and the controller are connected to transfer the program/erase routine from the controller to the device's internal RAM. This program/erase routine is then executed to program/erase the flash memory.

The program/erase routine is executed by sending commands and write data from the controller. The communications protocol between the device and the controller is described later in this manual. Before the program/erase routine can be transferred to the RAM, user password verification is performed to ensure the security of user ROM data. If the password is not verified correctly, the RAM transfer operation cannot be performed. In Single Boot mode, disable interrupts and use the interrupt request flags to check for an interrupt request.

Note: Do not change to another operation mode in the program/erase routine.

Not Recommended
for New Design

3.14.4.1 Using the program/erase algorithm in the internal boot ROM

(Step-1) Environment setup

Since the program/erase routine and write data are transferred via SIO (SIO1), connect the device's SIO (SIO1) and the controller on the board. The user must prepare the program/erase routine (a) on the controller.

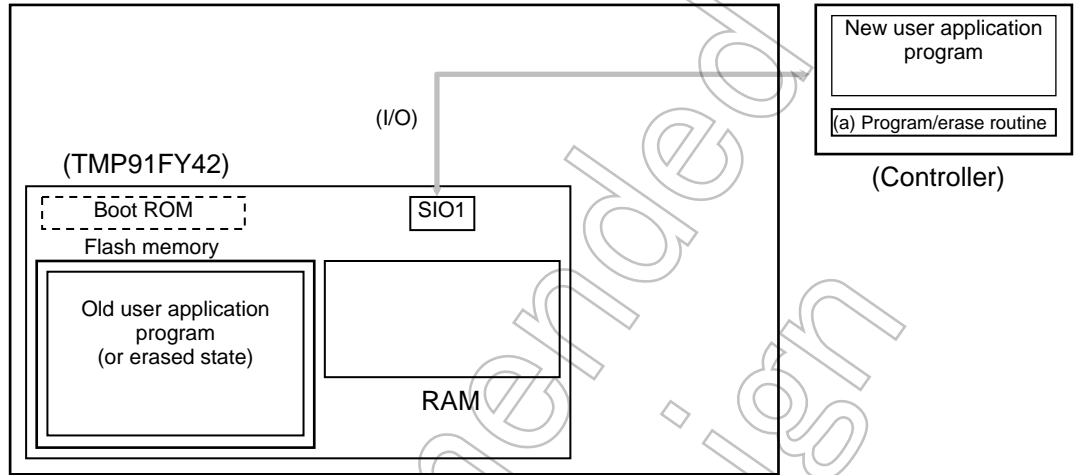

(Step-2) Starting up the internal boot ROM

Release the reset with the relevant input pins set for entering Single Boot mode. When the internal boot ROM starts up, the program/erase routine (a) is transferred from the controller to the internal RAM via SIO according to the communications procedure for Single Boot mode. Before this can be carried out, the password entered by the user is verified against the password written in the user application program. (If the flash memory has been erased, 12 bytes of "0xFF" are used as the password.)

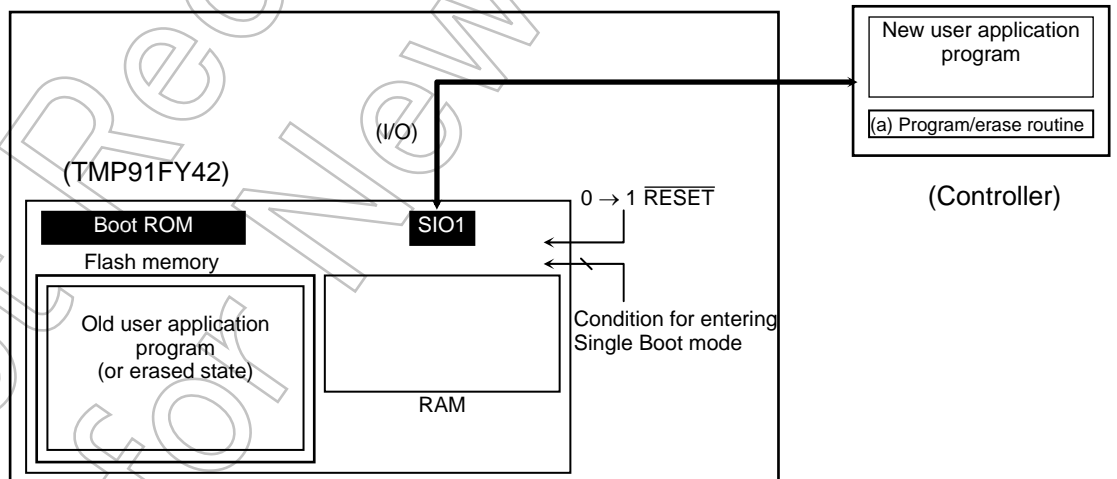

(Step-3) Copying the program/erase routine to the RAM

After password verification is completed, the boot ROM copies the program/erase routine (a) from the controller to the RAM using serial communications. The program/erase routine must be stored within the RAM address range of 001000H to 004DFFH.

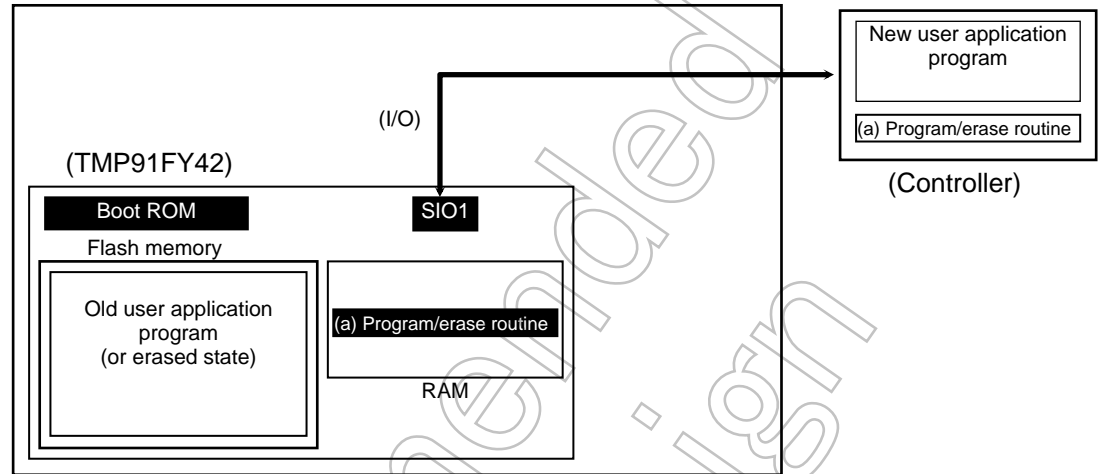

(Step-4) Executing the program/erase routine in the RAM

Control jumps to the program/erase routine (a) in the RAM. If necessary, the old user application program is erased (sector erase or chip erase).

Note: The boot ROM is provided with an erase command, which enables the entire chip to be erased from the controller without using the program/erase routine. If it is necessary to erase data on a sector basis, incorporate the necessary code in the program/erase routine.

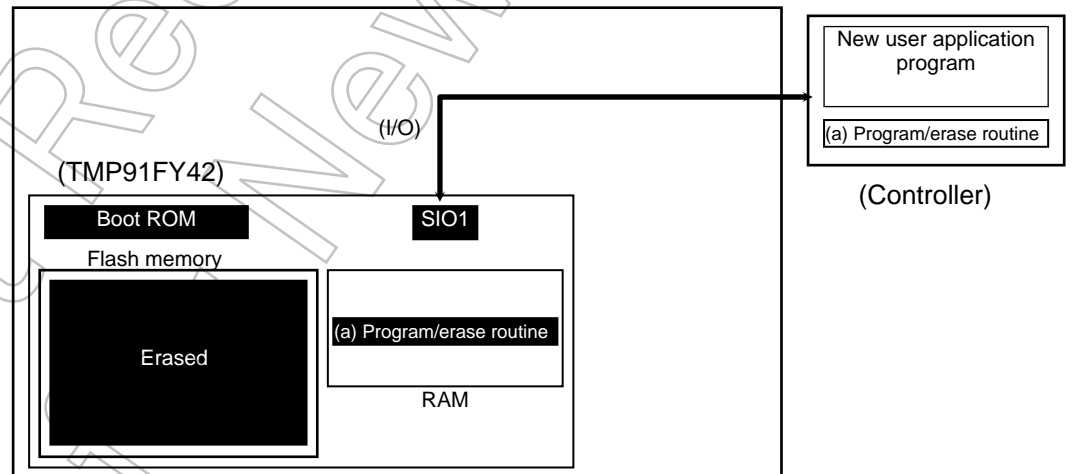

(Step-5) Copying the new user application program

The program/erase routine (a) loads the new user application program from the controller into the erased area of the flash memory.

In the example below, the new user application program is transferred under the same communications conditions as those used for transferring the program/erase routine. However, after the program/erase routine has been transferred, this routine can be used to change the transfer settings (data bus and transfer source). Configure the board hardware and program/erase routine as desired.

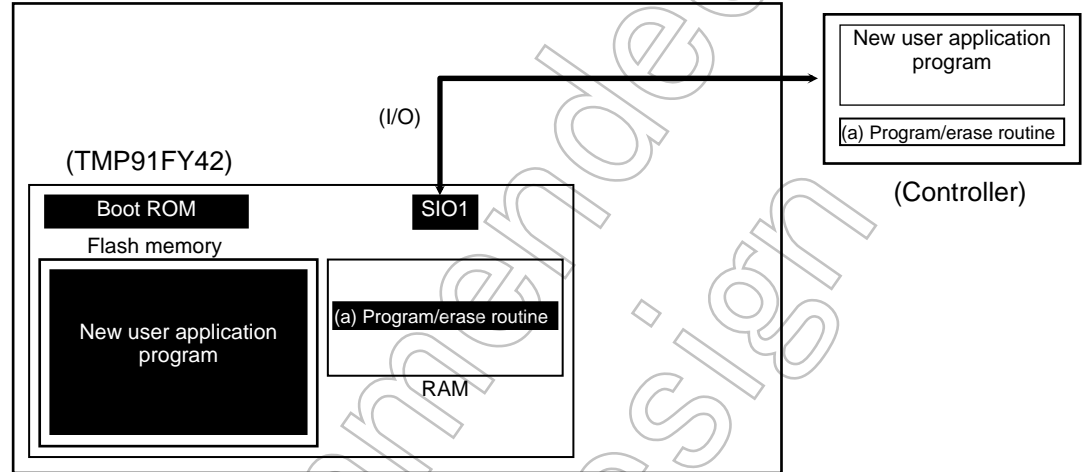

(Step-6) Executing the new user application program

After the programming operation has been completed, turn off the power to the board and remove the cable connecting the device and the controller. Then, turn on the power again and start up the device in Single Chip mode to execute the new user application program.

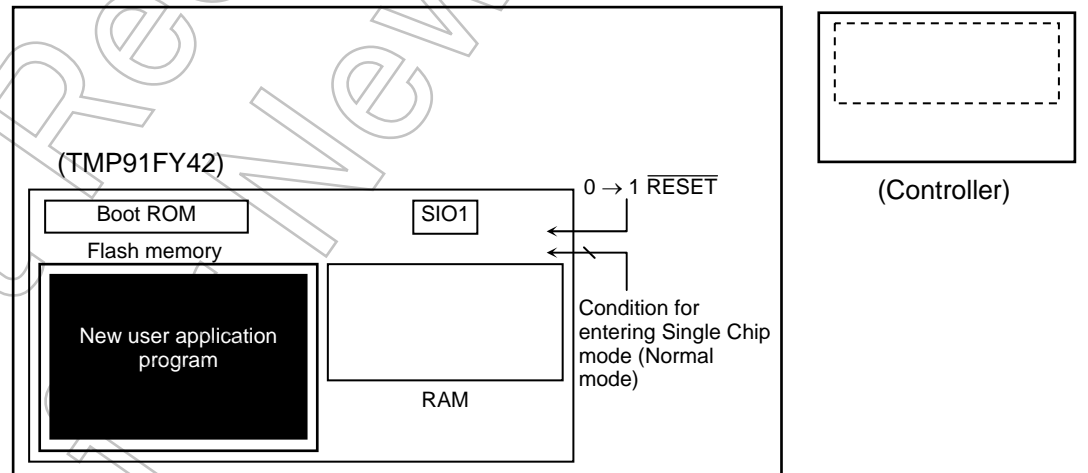

3.14.4.2 Connection Examples for Single Boot Mode

In Single Boot mode the flash memory is programmed by serial transfer. Therefore, on-board programming is performed by connecting the device's SIO (SIO1) and the controller (programming tool) and sending commands from the controller to the device. Figure 3.14.4 shows an example of connection between the target board and a programming controller. Figure 3.14.5 shows an example of connection between the target board and an RS232C board.

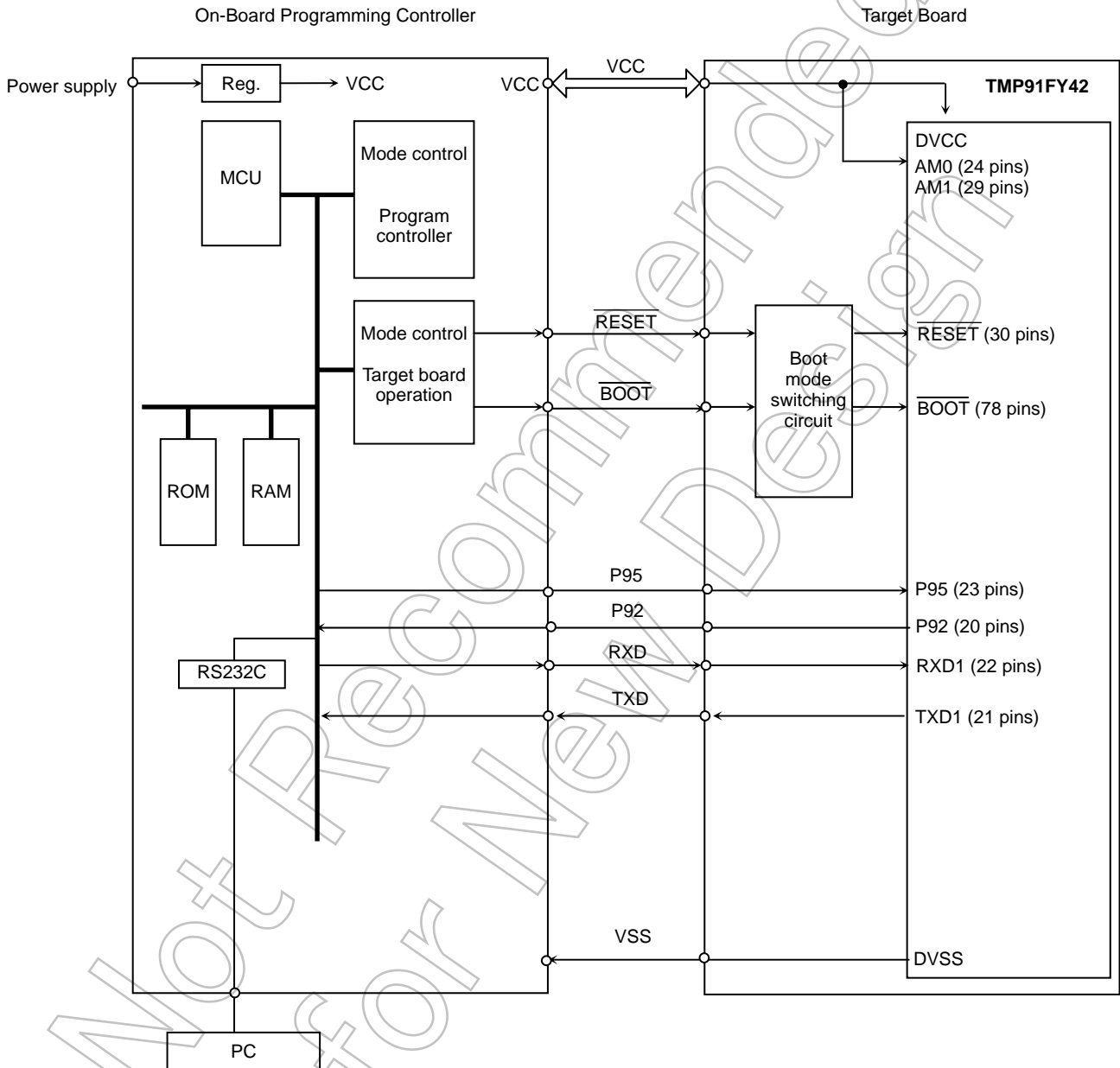

Figure 3.14.4 Example of Connection with an External Controller in Single Boot Mode

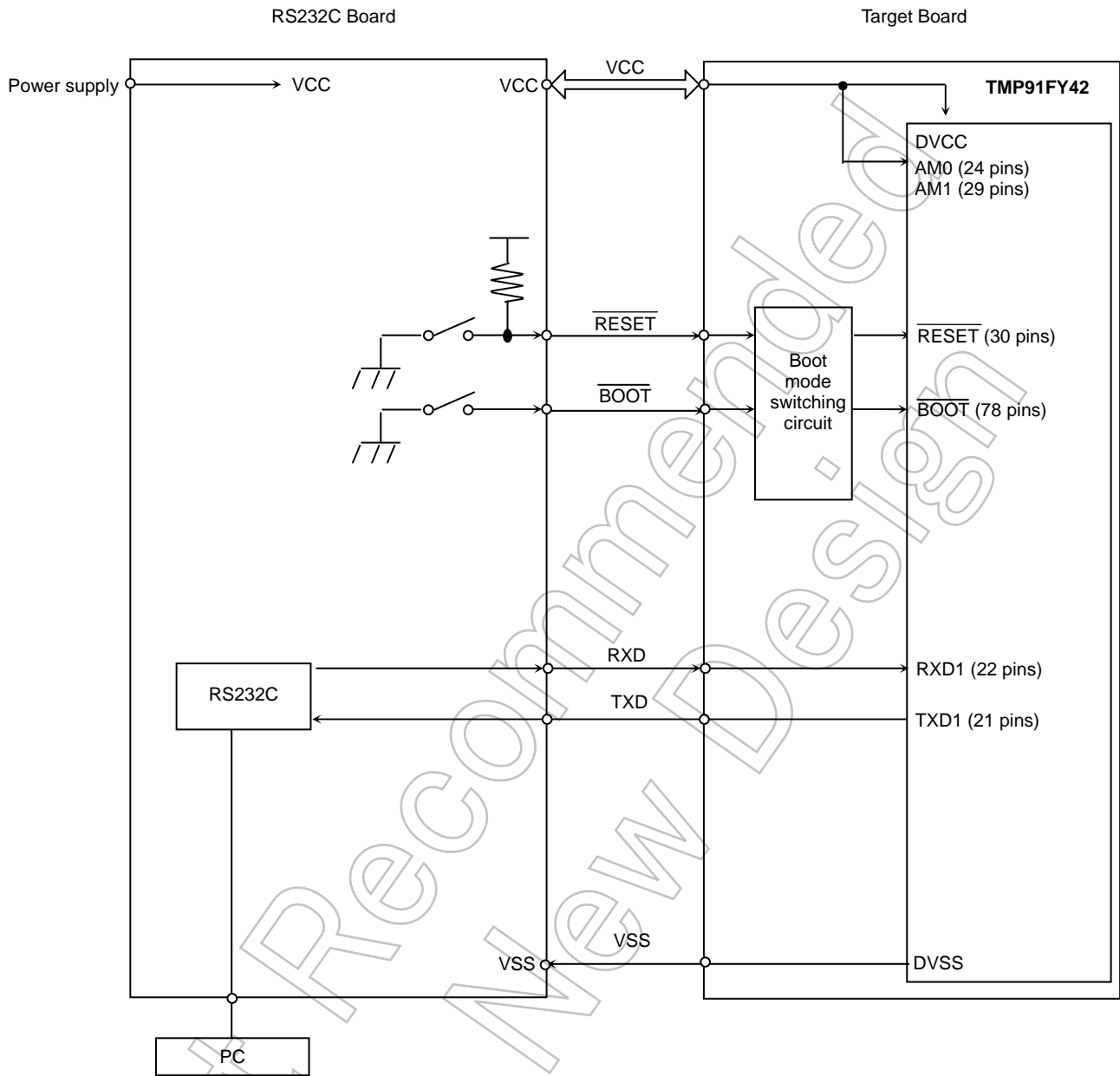

Figure 3.14.5 Example of Connection with an RS232C Board in Single Boot Mode

3.14.4.3 Mode Setting

To perform on-board programming, the device must be started up in Single Boot mode by setting the input pins as shown below.

- AM0,AM1 = 1
- $\overline{\text{BOOT}}$ = 0
- $\overline{\text{RESET}}$ = 0 → 1

Set the AM0, AM1, and $\overline{\text{BOOT}}$ pins as shown above with the $\overline{\text{RESET}}$ pin held at “0”. Then, setting the $\overline{\text{RESET}}$ pin to “1” will start up the device in Single Boot mode.

3.14.4.4 Memory Maps

Figure 3.14.6 shows a comparison of the memory map for Normal mode (in Single Chip mode) and the memory map for Single Boot mode. In Single Boot mode, the flash memory is mapped to addresses 10000H to 4FFFFH (physical addresses) and the boot ROM (mask ROM) is mapped to addresses FFF000H to FFFFFFFH.

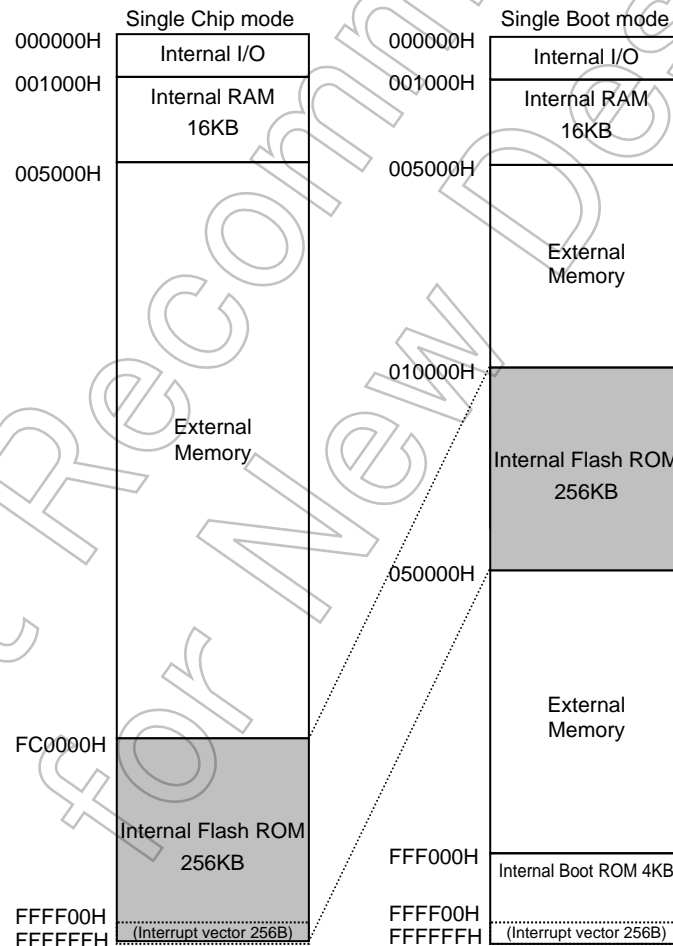

Figure 3.14.6 Comparison of Memory Maps

3.14.4.5 Interface Specifications

The SIO communications format in Single Boot mode is shown below. The device supports the UART (asynchronous communications) serial operation mode.

To perform on-board programming, the same communications format must also be set on the programming controller's side.

- UART (asynchronous) communications
 - Communications channel : SIO channel 1 (For the pins to be used, see Table 3.14.4.)
 - Serial transfer mode : UART (asynchronous communications) mode
 - Data length : 8 bits
 - Parity bit : None
 - Stop bit : 1 bit
 - Baud rate : See Table 3.14.5 and Table 3.14.6.

Table 3.14.4 Pin Connections

Pins		UART
Power supply pins	DVCC	○
	DVSS	○
Mode setting pins	AM1, AM0, BOOT	○
Reset pin	RESET	○
Communications pins	TXD1	○
	RXD1	○

Note: Unused pins are in the initial state after reset release.

Table 3.14.5 Baud Rate Table

SIO	Transfer Rate (bps)				
UART	115200	57600	38400	19200	9600

Table 3.14.6 Correspondence between Operating Frequency and Baud Rate in Single Boot Mode

Reference Baud Rate (bps)		9600		19200		38400		57600		115200	
Reference Frequency (MHz)	Supported Range (MHz)	Baud Rate (bps)	Error (%)	(bps)	(%)	(bps)	(%)	(bps)	(%)	(bps)	(%)
8	7.83~8.14	9615	+0.16	—	—	—	—	—	—	—	—
10	9.64~10.02	9766	+1.73	19531	+1.73	39063	+1.73	—	—	—	—
11.0592	10.84~11.28	9600	0	19200	0	—	—	—	—	—	—
12.2880	12.05~12.53	9600	0	19200	0	38400	0	—	—	—	—
14.7456	14.46~15.04	9600	0	19200	0	38400	0	57600	0	115200	0
16	15.66~16.29	9615	+0.16	19231	+0.16	—	—	—	—	—	—
18.4320	18.07~18.80	9600	0	19200	0	—	—	57600	0	—	—
20	19.27~20.05	9766	+1.73	19531	+1.73	39063	+1.73	—	—	—	—
22.1184	21.68~22.56	9600	0	19200	0	38400	0	57600	0	—	—
24.5760	24.09~25.06	9600	0	19200	0	38400	0	—	—	—	—
25		9766	+1.73	19531	+1.73	39063	+1.73	—	—	—	—
25.8048	25.29~26.32	9600	0	—	—	—	—	57600	0	—	—
27	26.50~27.57	9588	-0.13	19176	-0.13	38352	-0.13	—	—	—	—

Reference frequency: The frequency of the high-speed oscillation circuit that can be used in Single Boot mode.

To program the flash memory using Single Boot mode, one of the reference frequencies must be selected as a high-speed clock.

Supported Range: The range of clock frequencies that are detected as each reference frequency. It may not be possible to perform Single Boot operations at clock frequencies outside of the supported range.

Note: To automatically detect the reference frequency (microcontroller clock frequency), the transfer baud rate error of the flash memory programming controller and the oscillation frequency error must be within ±2% in total.

3.14.4.6 Data Transfer Formats

Table 3.14.7 to Table 3.14.14 show the operation command data and the data transfer format for each operation mode.

Table 3.14.7 Operation Command Data

Operation Command Data	Operation Mode
10H	RAM Transfer
20H	Flash Memory SUM
30H	Product Information Read
40H	Flash Memory Chip Erase
50H	Flash Memory Program
60H	Flash Memory Protect Set

Not Recommended
for New Design

Table 3.14.8 Transfer Format of Single Boot Program [RAM Transfer]

	Transfer Byte Number	Transfer Data from Controller to Device	Baud Rate	Transfer Data from Device to Controller
Boot ROM	1st byte	Baud rate setting UART 86H	Desired baud rate (Note 1)	—
	2nd byte	—		ACK response to baud rate setting Normal (baud rate OK) · UART (If the desired baud rate cannot be set, operation is terminated.) 86H
	3rd byte	Operation command data (10H)	-----	—
	4th byte	—		ACK response to operation command (Note 2) Normal Error Protection applied (Note 4) Communications error 10H x1H x6H x8H
	5th byte to 16th byte	Password data (12 bytes) (04FEF4H to 04FEFFH)		—
	17th byte	CHECKSUM value for 5th to 16th bytes		—
	18th byte	—		ACK response to CHECKSUM value (Note 2) Normal Error Communications error 10H 11H 18H
	19th byte	RAM storage start address 31 to 24 (Note 3)		—
	20th byte	RAM storage start address 23 to 16 (Note 3)		—
	21st byte	RAM storage start address 15 to 8 (Note 3)		—
	22nd byte	RAM storage start address 7 to 0 (Note 3)		—
	23rd byte	RAM storage byte count 15 to 8 (Note 3)		—
	24th byte	RAM storage byte count 7 to 0 (Note 3)		—
	25th byte	CHECKSUM value for 19th to 24th bytes (Note 3)		—
	26th byte	—		ACK response to CHECKSUM value (Note 2) Normal Error Communications error 10H 11H 18H
	27th byte to m'th byte	RAM storage data		—
	(m+1)th byte	CHECKSUM value for 27th to m'th bytes		—
	(m+2)th byte	—		ACK response to CHECKSUM value (Note 2) Normal Error Communications error 10H 11H 18H
RAM	(m+3)th byte	—		Jump to RAM storage start address

Note 1: For the desired baud rate setting, see Table 3.14.6.

Note 2: After sending an error response, the device waits for operation command data (3rd byte).

Note 3: The data to be transferred in the 19th to 25th bytes should be programmed within the RAM address range of 001000H to 004DFFH (15.8 Kbytes).

Note 4: When read protection or write protection is applied, the device aborts the received operation command and waits for the next operation command data (3rd byte).

Table 3.14.9 Transfer Format of Single Boot Program [Flash Memory SUM]

	Transfer Byte Number	Transfer Data from Controller to Device	Baud Rate	Transfer Data from Device to Controller
Boot ROM	1st byte	Baud rate setting UART 86H	Desired baud rate (Note1)	—
	2nd byte	—		ACK response to baud rate setting Normal (baud rate OK) ·UART 86H (If the desired baud rate cannot be set, operation is terminated.)
	3rd byte	Operation command data (20H)	—	—
	4th byte	—		ACK response to operation command (Note 2) Normal 20H Error x1H Communications error x8H
	5th byte	—		SUM (upper)
	6th byte	—		SUM (lower)
	7th byte	—		CHECKSUM value for 5th and 6th bytes
	8th byte	(Wait for the next operation command data)		

Note 1: For the desired baud rate setting, see Table 3.14.6.

Note 2: After sending an error response, the device waits for operation command data (3rd byte).

Table 3.14.10 Transfer Format of Single Boot Program [Product Information Read] (1/2)

	Transfer Byte Number	Transfer Data from Controller to Device	Baud Rate	Transfer Data from Device to Controller
Boot ROM	1st byte	Baud rate setting UART	86H	—
	2nd byte	—	Desired baud rate (Note 1)	ACK response to baud rate setting Normal (baud rate OK) ·UART 86H (If the desired baud rate cannot be set, operation is terminated.)
	3rd byte	Operation command data (30H)		—
	4th byte	—	-----	ACK response to operation command (Note2) Normal 30H Error x1H Communications error x8H
	5th byte	—		Flash memory data (address 04FEF0H)
	6th byte	—		Flash memory data (address 04FEF1H)
	7th byte	—		Flash memory data (address 04FEF2H)
	8th byte	—		Flash memory data (address 04FEF3H)
	9th byte to 20th byte	—		Part number (ASCII code, 12 bytes) 'TMP91FY42_ _ _ _' (from 9th byte)
	21st byte to 24th byte	—		Password comparison start address (4 bytes) F4H, FEH, 04H, 00H (from 21st byte)
	25th byte to 28th byte	—		RAM start address (4 bytes) 00H, 10H, 00H, 00H (from 25th byte)
	29th byte to 32nd byte	—		RAM (user area) end address (4 bytes) FFH, 4DH, 00H, 00H (from 29th byte)
	33rd byte to 36th byte	—		RAM end address (4 bytes) FFH, 4FH, 00H, 00H (from 33rd byte)
	37th byte to 40th byte	—		Dummy data (4 bytes) 00H, 00H, 00H, 00H (from 37th byte)
	41st byte to 44th byte	—		Dummy data (4 bytes) 00H, 00H, 00H, 00H (from 41st byte)
	45th byte to 46th byte	—		FUSE information (2 bytes from 45th byte) Read protection/Write protection 1) Applied/Applied : 00H, 00H 2) Not applied/Applied : 01H, 00H 3) Applied/Not applied : 02H, 00H 4) Not applied/Not applied : 03H, 00H
	47th byte to 50th byte	—		Flash memory start address (4 bytes) 00H, 00H, 01H, 00H (from 47th byte)
	51st byte to 54th byte	—		Flash memory end address (4 bytes) FFH, FFH, 04H, 00H (from 51st byte)
	55th byte to 56th byte	—		Number of sectors in flash memory (2 bytes) 40H, 00H (from 55th byte)
	57th byte to 60th byte	—		Start address of flash memory sectors of the same size (4 bytes) 00H, 00H, 01H, 00H (from 57th byte)

Table 3.14.11 Transfer Format of Single Boot Program [Product Information Read] (2/2)

	Transfer Byte Number	Transfer Data from Controller to Device	Baud rate	Transfer Data from Device to Controller
Boot ROM	61st byte to 64th byte	—		Size (in half words) of flash memory sectors of the same size (4 bytes) 00H, 08H, 00H, 00H (from 61st byte)
	65th byte	—		Number of flash memory sectors of the same size (1 byte) 40H
	66th byte	—		CHECKSUM value for 5th to 65th bytes
	67th byte	(Wait for the next operation command data)		—

Note 1: For the desired baud rate setting, see Table 3.14.6.

Note 2: After sending an error response, the device waits for operation command data (3rd byte).

Not Recommended for New Design

Table 3.14.12 Transfer Format of Single Boot Program [Flash Memory Chip Erase]

	Transfer Byte Number	Transfer Data from Controller to Device	Baud Rate	Transfer Data from Device to Controller
Boot ROM	1st byte	Baud rate setting UART 86H	Desired baud rate (Note 1)	—
	2nd byte	—		ACK response to baud rate setting Normal (baud rate OK) ·UART 86H (If the desired baud rate cannot be set, operation is terminated.)
	3rd byte	Operation command data (40H)		—
	4th byte	—		ACK response to operation command (Note2) Normal 40H Error x1H Communications error x8H
	5th byte	Erase Enable command data (54H)		—
	6th byte	—		ACK response to operation command (Note 2) Normal 54H Error x1H Communications error x8H
	7th byte	—		ACK response to Erase command Normal 4FH Error 4CH
	8th byte	—		ACK response Normal 5DH Error 60H
	9th byte	(Wait for the next operation command data)		—

Note 1: For the desired baud rate setting, see Table 3.14.6.

Note 2: After sending an error response, the device waits for operation command data (3rd byte).

Table 3.14.13 Transfer Format of Single Boot Program [Flash Memory Program]

	Transfer Byte Number	Transfer Data from Controller to Device	Baud Rate	Transfer Data from Device to Controller
Boot ROM	1st byte	Baud rate setting UART 86H	Desired baud rate (Note 1)	—
	2nd byte	—		ACK response to baud rate setting Normal (baud rate OK) ·UART 86H (If the desired baud rate cannot be set, operation is terminated.)
	3rd byte	Operation command data (50H)	-----	—
	4th byte	—		ACK response to operation command (Note 2) Normal 50H Error x1H Chip not erased (Note 4) x4H Protection applied (Note 5) x6H Communications error x8H
	5th byte	ROM storage start address 31 to 24 (Note 3)		—
	6th byte	ROM storage start address 23 to 16 (Note 3)		—
	7th byte	ROM storage start address 15 to 8 (Note 3)		—
	8th byte	ROM storage start address 7 to 0 (Note 3)		—
	9th byte	ROM storage byte count 15 to 8 (Note 3)		—
	10th byte	ROM storage byte count 7 to 0 (Note 3)		—
	11th byte	CHECKSUM value for 5th to 10th bytes (Note 3)		—
	12th byte	—		ACK response to CHECKSUM value (Note 2) Normal 50H Error 51H Communications error 58H
	13th byte to m'th byte	ROM storage data		—
	(m + 1)th byte	CHECKSUM value for 13th to m'th bytes		—
	(m + 2)th byte	—		ACK response to CHECKSUM value (Note 2) Normal 50H Error 51H Communications error 58H
	(m + 3)th byte	(Wait for the next operation command data)		—

Note 1: For the desired baud rate setting, see Table 3.14.6.

Note 2: After sending an error response, the device waits for operation command data (3rd byte).

Note 3: The data to be transferred in the 5th to 8th bytes should be programmed within the ROM address range of 010000H to 04FFFFH (256 Kbytes). Even-numbered addresses should be specified here.

The data to be transferred in the 9th and 10th bytes should be programmed within the address range of 0001H to 0400H (1 byte to 1 Kbytes). To program more than 1 Kbyte, repeat executing this command as necessary.

To rewrite data to Flash memory addresses at which data (including FFFFH) is already written, make sure to erase the existing data by chip erase before rewriting data.

Note 4: If the Flash Memory Chip Erase command (40H) has not been executed, the device aborts the received operation command and waits for the next operation command data (3rd byte). The Flash Memory Program command can only be accepted after the Flash Chip Erase command has been executed in Single Boot mode.

Note 5: When read protection or write protection is applied, the device aborts the received operation command and waits for the next operation command data (3rd byte).

Table 3.14.14 Transfer Format of Single Boot Program [Flash Memory Protect Set]

	Transfer Byte Number	Transfer Data from Controller to Device	Baud Rate	Transfer Data from Device to Controller	
Boot ROM	1st byte	Baud rate setting UART	Desired baud rate (Note 1)	—	
	2nd byte	—		ACK response to baud rate setting Normal (baud rate OK) ·UART	86H (If the desired baud rate cannot be set, operation is terminated.)
	3rd byte	Operation command data (60H)		—	
	4th byte	—		ACK response to operation command (Note2) Normal	60H Error
	5th byte to 16th byte	Password data (12 bytes) (04FEF4H to 04FEFFH)		—	—
	17th byte	CHECKSUM value for 5th to 16th bytes		—	—
	18th byte	—		ACK response to checksum value (Note 2) Normal	60H Error
	19th byte	—		ACK response to Protect Set command Normal	6FH Error
	20th byte	—		ACK response Normal	31H Error
	21st byte	(Wait for the next operation command data)		—	—

Note 1: For the desired baud rate setting, see Table 3.14.6.

Note 2: After sending an error response, the device waits for operation command data (3rd byte).

3.14.4.7 Boot Program

When the device starts up in Single Boot mode, the boot program is activated.

The following explains the commands that are used in the boot program to communicate with the controller when the device starts up in Single Boot mode. Use this information for creating a controller for using Single Boot mode or for building a user boot environment.

1. RAM Transfer command

In RAM transfer, data is transferred from the controller and stored in the device's internal RAM. When the transfer completes normally, the boot program will start running the transferred user program. Up to 15.8 Kbytes of data can be transferred as a user program. (This limit is implemented in the boot program to protect the stack pointer area.) The user program starts executing from the RAM storage start address. This RAM transfer function enables a user-created program/erase routine to be executed, allowing the user to implement their own on-board programming method. To perform on-board programming with a user program, the flash memory command sequences (see section 3.14.6) must be used. After the RAM Transfer command has been completed, the entire internal RAM area can be used.

If read protection or write protection is applied on the device or a password error occurs, this command will not be executed.

2. Flash Memory SUM command

This command calculates the SUM of 256 Kbytes of data in the flash memory and returns the result. There is no operation command available to the boot program for reading data from the entire area of the flash memory. Instead, this Flash Memory SUM command can be used. Reading the SUM value enables revision management of the application program.

3. Product Information Read command

This command returns the information about the device including its part number and memory details stored in the flash memory at addresses 04FEF0H to 04FEF3H. This command can also be used for revision management of the application program.

4. Flash Memory Chip Erase command

This command erases all the sectors in the flash memory. If read protection or write protection is applied on the device, all the sectors in the flash memory are erased and the read protection or write protection is cleared.

Since this command is also used to restore the operation of the boot program when the password is forgotten, it does not include password verification.

5. Flash Memory Program command

This command writes the data sent from the controller into the flash memory. Up to 1 Kbyte of data can be programmed at a time. To program more than 1 Kbyte, repeat executing this command as necessary.

After the device enters Single Boot mode, the Flash Memory Chip Erase command (40H) must be executed before the Flash Memory Program command can be executed.

If read protection or write protection is applied on the device, this command will not be executed.

6. Flash Memory Protect Set command

This command sets both read protection and write protection on the device. However, if a password error occurs, this command will not be executed.

When read protection is set, the flash memory cannot be read in Programmer mode. When write protection is set, the flash memory cannot be written in Programmer mode.

Not Recommended
for New Design

3.14.4.8 RAM Transfer Command (See Table 3.14.8)

1. From the controller to the device
The data in the 1st byte is used to determine the baud rate. The 1st byte is transferred with receive operation disabled (SC1MOD0<RXE> = 0). (The baud rate is determined using an internal timer.)
 - To communicate in UART mode
Send the value 86H from the controller to the target board using UART settings at the desired baud rate. If the serial operation mode is determined as UART, the device checks to see whether or not the desired baud rate can be set. If the device determines that the desired baud rate cannot be set, operation is terminated and no communications can be established.
2. From the device to the controller
The data in the 2nd byte is the ACK response returned by the device for the serial operation mode setting data sent in the 1st byte. If the data in the 1st byte is found to signify UART and the desired baud rate can be set, the device returns 86H.
 - Baud rate determination
The device determines whether or not the desired baud rate can be set. If it is found that the baud rate can be set, the boot program rewrites the BR1CR and BR1ADD values and returns 86H. If it is found that the desired baud rate cannot be set, operation is terminated and no data is returned. The controller sets a time-out time (5 seconds) after it has finished sending the 1st byte. If the controller does not receive the response (86H) normally within the time-out time, it should be considered that the device is unable to communicate. Receive operation is enabled (SC1MOD0<RXE> = 1) before 86H is written to the transmission buffer.
3. From the controller to the device
The data in the 3rd byte is operation command data. In this case, the RAM Transfer command data (10H) is sent from the controller to the device.
4. From the device to the controller
The data in the 4th byte is the ACK response to the operation command data in the 3rd byte. First, the device checks to see if the received data in the 3rd byte contains any error. If a receive error is found, the device returns the ACK response data for communications error (bit 3) x8H and waits for the next operation command data (3rd byte). The upper four bits of the ACK response data are undefined (They are the upper four bits of the immediately preceding operation command data).
Next, if the data received in the 3rd byte corresponds to one of the operation commands given in Table 3.14.7, the device echoes back the received data (ACK response for normal reception). In the case of the RAM Transfer command, if read or write protection is not applied, 10H is echoed back and then execution branches to the RAM transfer processing routine. If protection is applied, the device returns the corresponding ACK response data (bit 2/1) x6H and waits for the next operation command data (3rd byte). The upper four bits of the ACK response data are undefined. (They are the upper four bits of the immediately preceding operation command data.)
After branching to the RAM transfer processing routine, the device checks the data in the password area. For details, see 3.14.4.16 "Password".
If the data in the 3rd byte does not correspond to any operation command, the

device returns the ACK response data for operation command error (bit0) x1H and waits for the next operation command data (3rd byte). The upper four bits of the ACK response data are undefined. (They are the upper four bits of the immediately preceding operation command data.)

5. From the controller to the device
The 5th to 16th bytes contain password data (12 bytes). The data in the 5th to 16th bytes is verified against the data at addresses 04FEF4H to 04FEFFH in the flash memory, respectively.
6. From the controller to the device
The 17th byte contains CHECKSUM data. The CHECKSUM data sent by the controller is the two's complement of the lower 8-bit value obtained by summing the data in the 5th to 16th bytes by unsigned 8-bit addition (ignoring any overflow). For details on CHECKSUM, see 3.14.4.18 "How to Calculate CHECKSUM."
7. From the device to the controller
The data in the 18th byte is the ACK response data to the 5th to 17th bytes (ACK response to the CHECKSUM value). The device first checks to see whether the data received in the 5th to 17th bytes contains any error. If a receive error is found, the device returns the ACK response data for communications error (bit 3) 18H and waits for the next operation command data (3rd byte). The upper four bits of the ACK response data are the upper four bits of the immediately preceding operation command data, so the value of these bits is "1".
Next, the device checks the CHECKSUM data in the 17th byte. This check is made to see if the lower 8-bit value obtained by summing the data in the 5th to 17th bytes by unsigned 8-bit addition (ignoring any overflow) is 00H. If the value is not 00H, the device returns the ACK response data for CHECKSUM error (bit 0) 11H and waits for the next operation command data (3rd byte).
Finally, the device examines the result of password verification. If all the data in the 5th to 16th bytes is not verified correctly, the device returns the ACK response data for password error (bit 0) 11H and waits for the next operation command data (3rd byte).
If no error is found in all the above checks, the device returns the ACK response data for normal reception 10 H.
8. From the controller to the device
The data in the 19th to 22nd bytes indicates the RAM start address for storing block transfer data. The 19th byte corresponds to address bits 31 to 24, the 20th byte to address bits 23 to 16, the 21st byte to address bits 15 to 8, and the 22nd byte to address bits 7 to 0.
9. From the controller to the device
The data in the 23rd and 24th bytes indicates the number of bytes to be transferred. The 23rd byte corresponds to bits 15 to 8 of the transfer byte count and the 24th byte corresponds to bits 7 to 0.
10. From the controller to the device
The data in the 25th byte is CHECKSUM data. The CHECKSUM data sent by the controller is the two's complement of the lower 8-bit value obtained by summing the data in the 19th to 24th bytes by unsigned 8-bit addition (ignoring any

overflow). For details on CHECKSUM, see 3.14.4.18 "How to Calculate CHECKSUM."

Note: The data in the 19th to 25th bytes should be placed within addresses 001000H to 004DFFH (15.8 Kbytes) in the internal RAM.

11. From the device to the controller

The data in the 26th byte is the ACK response data to the data in the 19th to 25th bytes (ACK response to the CHECKSUM value).

The device first checks to see whether the data received in the 19th to 25th bytes contains any error. If a receive error is found, the device returns the ACK response data for communications error (bit 3) 18H and waits for the next operation command (3rd byte). The upper four bits of the ACK response data are the upper four bits of the immediately preceding operation command data, so the value of these bits is "1".

Next, the device checks the CHECKSUM data in the 25th byte. This check is made to see if the lower 8-bit value obtained by summing the data in the 19th to 25th bytes by unsigned 8-bit addition (ignoring any overflow) is 00H. If the value is not 00H, the device returns the ACK response data for CHECKSUM error (bit 0) 11H and waits for the next operation command data (3rd byte).

12. From the controller to the device

The data in the 27th to mth bytes is the data to be stored in the RAM. This data is written to the RAM starting at the address specified in the 19th to 22nd bytes. The number of bytes to be written is specified in the 23rd and 24th bytes.

13. From the controller to the device

The data in the (m+1)th byte is CHECKSUM data. The CHECKSUM data sent by the controller is the two's complement of the lower 8-bit value obtained by summing the data in the 27th to mth bytes by unsigned 8-bit addition (ignoring any overflow). For details on CHECKSUM, see 3.14.4.18 "How to Calculate CHECKSUM."

14. From the device to the controller

The data in the (m + 2)th byte is the ACK response data to the 27th to (m+1)th bytes (ACK response to the CHECKSUM value).

The device first checks to see whether the data in the 27th to (m+1)th byte contains any error. If a receive error is found, the device returns the ACK response data for communications error (bit 3) 18H and waits for the next operation command (3rd byte). The upper four bits of the ACK response are the upper four bits of the immediately preceding operation command data, so the value of these bits is "1".

Next, the device checks the CHECKSUM data in the (m+1)th byte. This check is made to see if the lower 8-bit value obtained by summing the data in the 27th to (m+1)th bytes by unsigned 8-bit addition (ignoring any overflow) is 00H. If the value is not 00H, the device returns the ACK response data for CHECKSUM error (bit 0) 11H and waits for the next operation command data (3rd byte).

If no error is found in all the above checks, the device returns the ACK response data for normal reception 10H.

15. From the device to the controller

If the ACK response data in the (m + 2)th byte is 10H (normal reception), the boot program then jumps to the RAM start address specified in the 19th to 22nd bytes.

3.14.4.9 Flash Memory SUM command (See Table 3.14.9)

1. The data in the 1st and 2nd bytes is the same as in the case of the RAM Transfer command.

2. From the controller to the device

The data in the 3rd byte is operation command data. The Flash Memory SUM command data (20H) is sent here.

3. From the device to the controller

The data in the 4th byte is the ACK response data to the operation command data in the 3rd byte.

The device first checks to see if the data in the 3rd byte contains any error. If a receive error is found, the device returns the ACK response data for communications error (bit 3) x8H and waits for the next operation command data (3rd byte). The upper four bits of the ACK response data are undefined. (They are the upper four bits of the immediately preceding operation command data.)

Then, if the data in the 3rd byte corresponds to one of the operation command values given in Table 3.14.7, the device echoes back the received data (ACK response for normal reception). In this case, 20H is echoed back and execution then branches to the flash memory SUM processing routine. If the data in the 3rd byte does not correspond to any operation command, the device returns the ACK response data for operation command error (bit 0) x1H and waits for the next operation command data (3rd byte). The upper four bits of the ACK response data are undefined. (They are the upper four bits of the immediately preceding operation command data.)

4. From the device to the controller

The data in the 5th and 6th bytes is the upper and lower data of the SUM value, respectively. For details on SUM, see 3.14.4.17 "How to Calculate SUM."

5. From the device to the controller

The data in the 7th byte is CHECKSUM data. This is the two's complement of the lower 8-bit value obtained by summing the data in the 5th and 6th bytes by unsigned 8-bit addition (ignoring any overflow).

6. From the controller to the device

The data in the 8th byte is the next operation command data.

3.14.4.10 Product Information Read command (See Table 3.14.10 and Table 3.14.11)

1. The data in the 1st and 2nd bytes is the same as in the case of the RAM Transfer command.
2. From the controller to the device
The data in the 3rd byte is operation command data. The Product Information Read command data (30H) is sent here.
3. From the device to the controller
The data in the 4th byte is the ACK response data to the operation command data in the 3rd byte.
The device first checks to see if the data in the 3rd byte contains any error. If a receive error is found, the device returns the ACK response data for communications error (bit 3) x8H and waits for the next operation command data (3rd byte). The upper four bits of the ACK response data are undefined. (They are the upper four bits of the immediately preceding operation command data.)
Then, if the data in the 3rd byte corresponds to one of the operation command values given in Table 3.14.7, the device echoes back the received data (ACK response for normal reception). In this case, 30H is returned and execution then branches to the product information read processing routine. If the data in the 3rd byte does not correspond to any operation command, the device returns the ACK response data for operation command error (bit 0) x1H and waits for the next operation command data (3rd byte). The upper four bits of the ACK response data are undefined. (They are the upper four bits of the immediately preceding operation command data.)
4. From the device to the controller
The data in the 5th to 8th bytes is the data stored at addresses 04FEF0H to 04FEF3H in the flash memory. By writing the ID information of software at these addresses, the version of the software can be managed. (For example, 0002H can indicate that the software is now in version 2.)
5. From the device to the controller
The data in the 9th to 20th bytes denotes the part number of the device. 'TMP91FY42_ _ _' is sent in ASCII code starting from the 9th byte.
Note: An underscore ('_') indicates a space.
6. From the device to the controller
The data in the 21st to 24th bytes is the password comparison start address. F4H, FEH, 04H and 00H are sent starting from the 21st byte.
7. From the device to the controller
The data in the 25th to 28th bytes is the RAM start address. 00H, 10H, 00H and 00H are sent starting from the 25th byte.
8. From the device to the controller
The data in the 29th to 32nd bytes is the RAM (user area) end address. FFH, 4DH, 00H and 00H are sent starting from the 29th byte.
9. From the device to the controller

The data in the 33rd to 36th bytes is the RAM end address. FFH, 4FH, 00H and 00H are sent starting from the 33rd byte.

10. From the device to the controller
The data in the 37th to 44th bytes is dummy data.
11. From the device to the controller
The data in the 45th and 46th bytes contains the protection status and sector division information of the flash memory.
 - Bit 0 indicates the read protection status.
 - 0: Read protection is applied.
 - 1: Read protection is not applied.
 - Bit 1 indicates the write protection status.
 - 0: Write protection is applied.
 - 1: Write protection is not applied.
 - Bit 2 indicates whether or not the flash memory is divided into sectors.
 - 0: The flash memory is divided into sectors.
 - 1: The flash memory is not divided into sectors.
 - Bits 3 to 15 are sent as "0".
12. From the device to the controller
The data in the 47th to 50th bytes is the flash memory start address. 00H, 00H, 01H and 00H are sent starting from the 47th byte.
13. From the device to the controller
The data in the 51st to 54th bytes is the flash memory end address. FFH, FFH, 04H and 00H are sent starting from the 51st byte.
14. From the device to the controller
The data in the 55th and 56th bytes indicates the number of sectors in the flash memory. 40H and 00H are sent starting from the 55th byte.
15. From the device to the controller
The data in the 57th to 65th bytes contains sector information of the flash memory. Sector information is comprised of the start address (starting from the flash memory start address), sector size and number of consecutive sectors of the same size. Note that the sector size is represented in word units.
The data in the 57th to 65th bytes indicates 4 Kbytes of sectors (sector 0 to sector 63).
For the data to be transferred, see Table 3.14.10 and Table 3.14.11.
16. From the device to the controller
The data in the 66th byte is CHECKSUM data. This is the two's complement of the lower 8-bit value obtained by summing the data in the 5th to 65th bytes by unsigned 8-bit addition (ignoring any overflow).
17. From the controller to the device
The data in the 67th byte is the next operation command data.

3.14.4.11 Flash Memory Chip Erase Command (See Table 3.14.12)

1. The data in the 1st and 2nd bytes is the same as in the case of the RAM Transfer command.
2. From the controller to the device
The data in the 3rd byte is operation command data. The Flash Memory Chip Erase command data (40H) is sent here.
3. From the device to the controller
The data in the 4th byte is the ACK response data to the operation command data in the 3rd byte.
The device first checks to see if the data in the 3rd byte contains any error. If a receive error is found, the device returns the ACK response data for communications error (bit 3) x8H and waits for the next operation command data (3rd byte). The upper four bits of the ACK response data are undefined. (They are the upper four bits of the immediately preceding operation command data.)
Then, if the data in the 3rd byte corresponds to one of the operation command values given in Table 3.14.7, the device echoes back the received data (ACK response for normal reception). In this case, 40H is echoed back. If the data in the 3rd byte does not correspond to any operation command, the device returns the ACK response data for operation command error (bit 0) x1H and waits for the next operation command data (3rd byte). The upper four bits of the ACK response data are undefined. (They are the upper four bits of the immediately preceding operation command data.)
4. From the controller to the device
The data in the 5th byte is Erase Enable command data (54H).
5. From the device to the controller
The data in the 6th byte is the ACK response data to the Erase Enable command data in the 5th byte.
The device first checks to see if the data in the 5th byte contains any error. If a receive error is found, the device returns the ACK response data for communications error (bit 3) x8H and waits for the next operation command data (3rd byte). The upper four bits of the ACK response data are undefined (They are the upper four bits of the immediately preceding operation command data.)
Then, if the data in the 5th byte corresponds to the Erase Enable command data, the device echoes back the received data (ACK response for normal reception). In this case, 54H is echoed back and execution jumps to the flash memory chip erase processing routine. If the data in the 5th byte does not correspond to the Erase Enable command data, the device returns the ACK response data for operation command error (bit 0) x1H and waits for the next operation command (3rd byte). The upper four bits of the ACK response data are undefined. (They are the upper four bits of the immediately preceding operation command data.)
6. From the device to the controller
The data in the 7th byte indicates whether or not the erase operation has completed successfully. If the erase operation has completed successfully, the device returns the end code (4FH). If an erase error has occurred, the device returns the error code (4CH).

7. From the device to the controller
The data in the 8th byte is ACK response data. If the erase operation has completed successfully, the device returns the ACK response for erase completion (5DH). If an erase error has occurred, the device returns the ACK response for erase error (60H).
8. From the controller to the device
The data in the 9th byte is the next operation command data.

Not Recommended
for New Design

3.14.4.12 Flash Memory Program Command (See Table 3.14.13)

1. The data in the 1st and 2nd bytes is the same as in the case of the RAM Transfer command.
2. From the controller to the device
The data in the 3rd byte is operation command data. The Flash Memory Program command data (50H) is sent here.
3. From the device to the controller
The data in the 4th byte is the ACK response data to the operation command data in the 3rd byte.
The device first checks to see if the data in the 3rd byte contains any error. If a receive error is found, the device returns the ACK response data for communications error (bit 3) x8H and waits for the next operation command data (3rd byte). The upper four bits of the ACK response data are undefined. (They are the upper four bits of the immediately preceding operation command data.)
Then, if the data in the 3rd byte corresponds to one of the operation command values given in Table 3.14.7, the device echoes back the received data (ACK response for normal reception). In the case of the Flash Memory Program command (50H), the device checks to see that read or write protection is not applied and that the Flash Memory Chip Erase command (40H) has been executed. If these two conditions are satisfied, the device echoes back 50H and branches to the flash memory program processing routine.
If protection is applied, the device returns the corresponding ACK response data (bit2/1) x6H and waits for the next operation command data (3rd byte). If the Flash Memory Chip Erase command (40H) has not been executed, the device returns the corresponding ACK response data (bit 2) x4H and waits for the next operation command data (3rd byte). If the data in the 3rd byte does not correspond to any operation command, the device returns the ACK response data for operation command error (bit 0) x1H and waits for the next operation command data (3rd byte). The upper four bits of the ACK response data (x6 H / x4 H /x1H) are undefined. (They are the upper four bits of the immediately preceding operation command data.)
4. From the controller to the device
The data in the 5th to 8th bytes indicates the flash memory start address for storing block transfer data. The 5th byte corresponds to address bits 31 to 24, the 6th byte to address bits 23 to 16, and the 7th byte to address bits 15 to 8, and the 8th byte to address bits 7 to 0.
5. From the controller to the device
The data in the 9th and 10th bytes indicates the number of bytes to be transferred. The 9th byte corresponds to bits 15 to 8 of the transfer byte count and the 10th byte to address bits 7 to 0.
6. From the controller to the device
The data in the 11th byte is CHECKSUM data. The CHECKSUM data sent from the controller is the two's complement of the lower 8-bit value obtained by summing the data in the 5th to 10th bytes by unsigned 8-bit addition (ignoring

any overflow). For details on CHECKSUM, see 3.14.4.18 "How to Calculate CHECKSUM."

Note: The data to be transferred in the 5th to 8th bytes should be programmed within the ROM address range of 010000H to 04FFFFH (256 Kbytes). Even-numbered addresses should be specified here. The data to be transferred in the 9th and 10th bytes should be programmed within addresses 0001H to 0400H (1 byte to 1 Kbytes). To program more than 1 Kbyte, repeat executing this command as necessary. To rewrite data to Flash memory addresses at which data (including FFFFH) is already written, make sure to erase the existing data by chip erase before rewriting data.

7. From the device to the controller

The data in the 12th byte is the ACK response data to the data in the 5th to 11th bytes (ACK response to the CHECKSUM value).

The device first checks to see if the data in the 5th to 11th bytes contains any error. If a receive error is found, the device returns the ACK response data for communications error (bit 3) 58H and waits for the next operation command data (3rd byte). The upper four bits of the ACK response data are the upper four bits of the immediately preceding operation command data, so the value of these bits is "5".

Then, the device checks the CHECKSUM data in the 11th byte. This check is made to see if the lower 8-bit value obtained by summing the unsigned 8-bit data in the 5th to 11th bytes (ignoring any overflow) is 00H. If the value is not 00H, the device returns the ACK response data for CHECKSUM error (bit 0) 51H and waits for the next operation command data (3rd byte).

If no error is found in the above checks, the device returns the ACK response data for normal reception 50H.

8. From the controller to the device

The data in the 13th to m'th byte is the data to be stored in the flash memory. This data is written from the flash memory address specified in the 5th to 8th bytes. The number of bytes to be written is specified in the 9th and 10th bytes.

9. From the controller to the device

The data in the (m + 1)th byte is CHECKSUM data. The CHECKSUM data sent by the controller is the two's complement of the lower 8-bit value obtained by summing the data in the 13th to m'th bytes by unsigned 8-bit addition (ignoring any overflow). For details on CHECKSUM, see 3.14.4.18 "How to Calculate CHECKSUM."

10. From the device to the controller

The data in the (m+2)th byte is the ACK response data to the data in the 13th to (m+1)th bytes (ACK response to the CHECKSUM value).

The device first checks to see if the data in the 13th to (m+1)th bytes contains any error. If a receive error is found, the device returns the ACK response data for communications error (bit 3) 58H and waits for the next operation command data (3rd byte). The upper four bits of the ACK response data are the upper four bits of the immediately preceding operation command data, so the value of these bits is "5".

Then, the device checks the CHECKSUM data in the (m+1)th byte. This check is made to see if the lower 8-bit value obtained by summing the data in the 13th to (m+1)th bytes by unsigned 8-bit addition (ignoring any overflow) is 00H. If the value is not 00H, the device returns the ACK response data for CHECKSUM error (bit 0) 51H and waits for the next operation command (3rd byte).

If no error is found in the above checks, the device returns the ACK response data for normal reception 50H.

11. From the controller to the device

The data in the (m + 3) byte is the next operation command data.

Not Recommended
for New Design

3.14.4.13 Flash Memory Protect Set command (See Table 3.14.14)

1. The data in the 1st and 2nd bytes is the same as in the case of the RAM Transfer command.

2. From the controller to the device

The data in the 3rd byte is operation command data. The Flash Memory Protect Set command data (60H) is sent here.

3. From the device to the controller

The data in the 4th byte is the ACK response data to the operation command data in the 3rd byte.

The device first checks to see if the data in the 3rd byte contains any error. If a receive error is found, the device returns the ACK response data for communications error (bit 3) x8H and waits for the next operation command data. The upper four bits of the ACK response data are undefined. (They are the upper four bits of the immediately preceding operation command data.)

Then, if the data in the 3rd byte corresponds to one of the operation command data values given in Table 3.14.7, the device echoes back the received data (ACK response for normal reception). In this case, 60H is echoed back and execution branches to the flash memory protect set processing routine.

After branching to this routine, the data in the password area is checked. For details, see 3.14.4.16 "Password."

If the data in the 3rd byte does not correspond to any operation command, the device returns the ACK response data for operation command error (bit 0) x1H and waits for the next operation command data (3rd byte). The upper four bits of the ACK response data are undefined. (They are the upper four bits of the immediately preceding operation command data.)

4. From the controller to the device

The data in the 5th to 16th bytes is password data (12 bytes). The data in the 5th byte is verified against the data at address 04FEF4H in the flash memory and the data in the 6th byte against the data at address 04FEF5H. In this manner, the received data is verified consecutively against the data at the specified address in the flash memory. The data in the 16th byte is verified against the data at address 04FEFFH in the flash memory.

5. From the controller to the device

The data in the 17th byte is CHECKSUM data. The CHECKSUM data sent by the controller is the two's complement of the lower 8-bit value obtained by summing the data in 5th to 16th bytes by unsigned 8-bit addition (ignoring any overflow). For details on CHECKSUM, see 3.14.4.18 "How to Calculate CHECKSUM."

6. From the device to the controller

The data in the 18th byte is the ACK response data to the data in the 5th to 17th bytes (ACK response to the CHECKSUM value).

The device first checks to see whether the data in the 5th to 17th bytes contains any error. If a receive error is found, the device returns the ACK response data for communications error (bit 3) 68H and waits for the next operation command data (3rd byte). The upper four bits of the ACK response data are the upper four bits of the immediately preceding operation command data, so the value of these bits is "6".

Then, the device checks the CHECKSUM data in the 17th byte. This check is made to see if the lower 8 bits of the value obtained by summing the data in the 5th to 17th bytes by unsigned 8-bit addition (ignoring any overflow) is 00H. If the value is not 00H, the device returns the ACK response data for CHECKSUM error (bit 0) 61H and waits for the next operation command data (3rd byte).

Finally, the device examines the result of password verification. If all the data in the 5th to 16th bytes is not verified correctly, the device returns the ACK response data for password error (bit 0) 61H and waits for the next operation command data (3rd byte).

If no error is found in the above checks, the device returns the ACK response data for normal reception 60H.

7. From the device to the controller

The data in the 19th byte indicates whether or not the protect set operation has completed successfully. If the operation has completed successfully, the device returns the end code (6FH). If an error has occurred, the device returns the error code (6CH).

8. From the device to the controller

The data in the 20th byte is ACK response data. If the protect set operation has completed successfully, the device returns the ACK response data for normal completion (31H). If an error has occurred, the device returns the ACK response data for error (34H).

9. From the device to the controller

The data in the 21st byte is the next operation command data.

3.14.4.14 ACK Response Data

The boot program notifies the controller of its processing status by sending various response data. Table 3.14.15 to Table 3.14.21 show the ACK response data returned for each type of received data. The upper four bits of ACK response data are a direct reflection of the upper four bits of the immediately preceding operation command data. Bit 3 indicates a receive error and bit 0 indicates an operation command error, CHECKSUM error or password error.

Table 3.14.15 ACK Response Data to Serial Operation Mode Setting Data

Transfer Data	Meaning
86H	The device can communicate in UART mode. (Note)

Note: If the desired baud rate cannot be set, the device returns no data and terminates operation.

Table 3.14.16 ACK Response Data to Operation Command Data

Transfer Data	Meaning
x8H (Note)	A receive error occurred in the operation command data.
x6H (Note)	Terminated receive operation due to protection setting.
x4H (Note)	Terminated receive operation as the Flash Memory Chip Erase command has not been executed.
x1H (Note)	Undefined operation command data was received normally.
10H	Received the RAM Transfer command.
20H	Received the Flash Memory SUM command.
30H	Received the Product Information Read command.
40H	Received the Flash Memory Chip Erase command.
50H	Received the Flash Memory Program command.
60H	Received the Flash Memory Protect Set command.

Note: The upper four bits are a direct reflection of the upper four bits of the immediately preceding operation command data.

Table 3.14.17 ACK Response data to CHECKSUM Data for RAM Transfer Command

Transfer Data	Meaning
18H	A receive error occurred.
11H	A CHECKSUM error or password error occurred.
10H	Received the correct CHECKSUM value.

Table 3.14.18 ACK Response Data to Flash Memory Chip Erase Operation

Transfer Data	Meaning
54H	Received the Erase Enable command.
4FH	Completed erase operation.
4CH	An erase error occurred.
5DH (Note)	Reconfirmation of erase operation
60H (Note)	Reconfirmation of erase error

Note: These codes are returned for reconfirmation of communications.

Table 3.14.19 ACK Response Data to CHECKSUM Data for Flash Memory Program Command

Transfer Data	Meaning
58H	A receive error occurred.
51H	A CHECKSUM error occurred.
50H	Received the correct CHECKSUM value.

Table 3.14.20 ACK Response Data to CHECKSUM Data for Flash Memory Protect Set Command

Transfer Data	Meaning
68H	A receive error occurred.
61H	A CHECKSUM or password error occurred.
60H	Received the correct CHECKSUM value.

Table 3.14.21 ACK Response Data to Flash Memory Protect Set Operation

Transfer Data	Meaning
6FH	Completed the protect (read/write) set operation.
6CH	A protect (read/write) set error occurred.
31H (Note)	Reconfirmation of protect (read/write) set operation
34H (Note)	Reconfirmation of protect (read/write) set error

Note: These codes are returned for reconfirmation of communications.

3.14.4.15 Determining Serial Operation Mode

To communicate in UART mode, the controller should transmit the data value 86H as the first byte at the desired baud rate. Figure 3.14.7 shows the waveform of this operation.

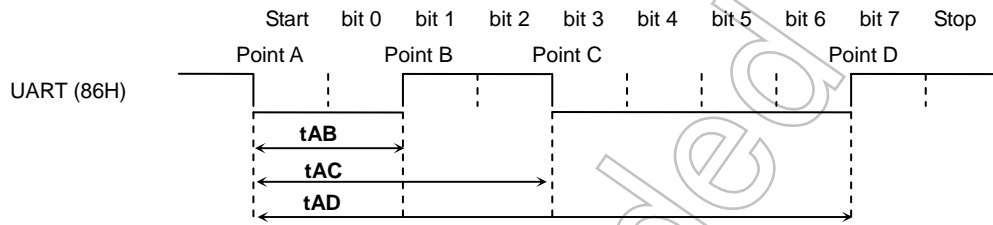

Figure 3.14.7 Data for Determining Serial Operation Mode

The boot program receives the first byte (86H) after reset release not as serial communications data. Instead, the boot program uses the first byte to determine the baud rate. The baud rate is determined by the output periods of t_{AB} , t_{AC} and t_{AD} as shown in Figure 3.14.7 using the procedure shown in Figure 3.14.8.

The CPU monitors the level of the receive pin. Upon detecting a level change, the CPU captures the timer value to determine the baud rate.

Not Recommended for New Design

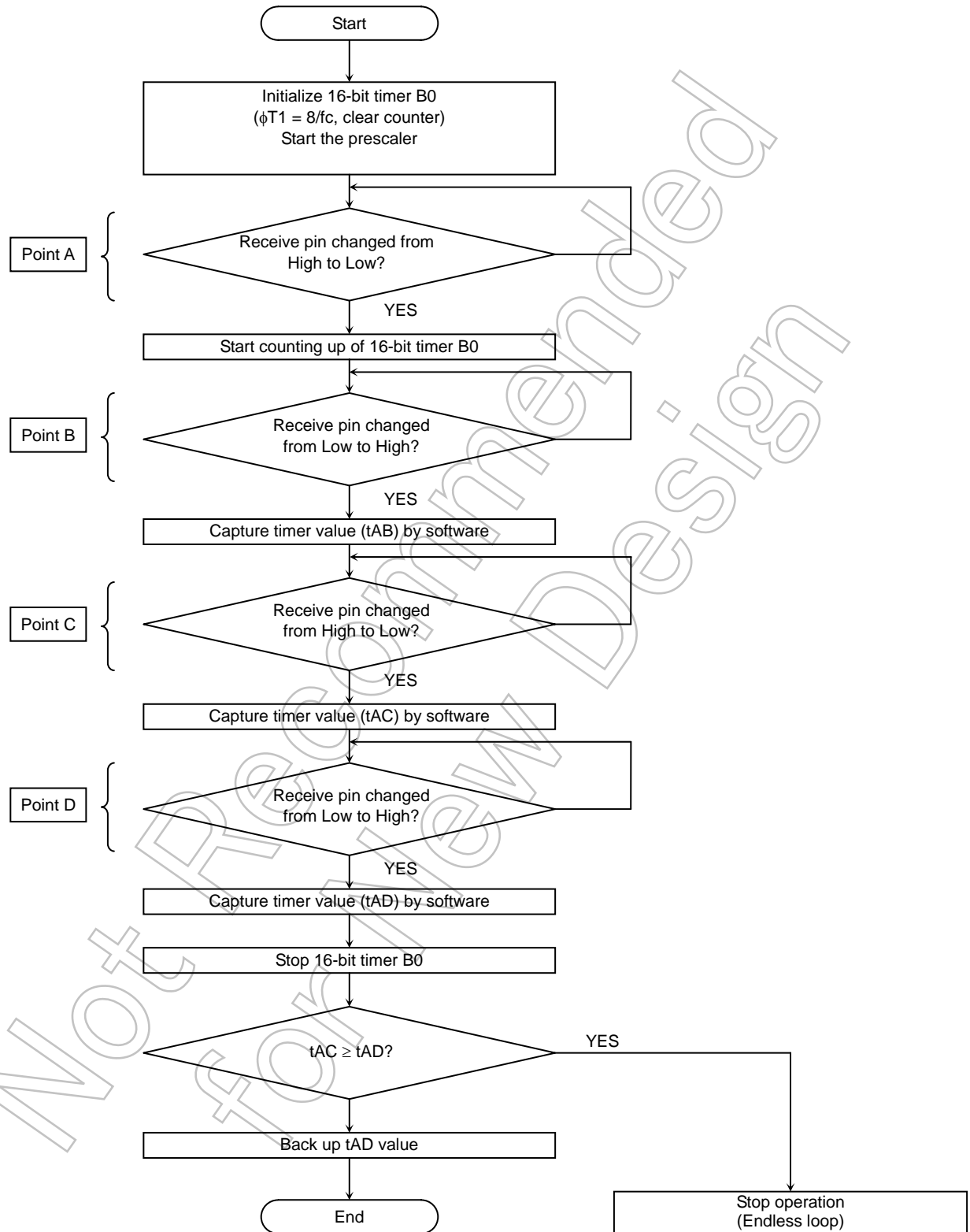

Figure 3.14.8 Flowchart for Serial Operation Mode Receive Operation

3.14.4.16 Password

When the RAM Transfer command (10H) or the Flash Memory Protect Set command (60H) is received as operation command data, password verification is performed. First, the device echoes back the operation command data (10H to 60H) and checks the data (12 bytes) in the password area (addresses 04FEF4H to 04FEFFH).

Then, the device verifies the password data received in the 5th to 16th bytes against the data in the password area as shown in Table 3.14.22.

Unless all the 12 bytes are verified correctly, a password error will occur.

A password error will also occur if all the 12 bytes of password data contain the same value. Only exception is when all the 12 bytes are "FFH" and verified correctly and the reset vector area (addresses 04FF00H to 04FF02H) is all "FFH". In this case, a blank device will be assumed and no password error will occur.

If a password error has occurred, the device returns the ACK response data for password error in the 18th byte.

Table 3.14.22 Password Verification Table

Receive data	Data to be verified against
5th byte	Data at address 04FEF4H
6th byte	Data at address 04FEF5H
7th byte	Data at address 04FEF6H
8th byte	Data at address 04FEF7H
9th byte	Data at address 04FEF8H
10th byte	Data at address 04FEF9H
11th byte	Data at address 04FEFAH
12th byte	Data at address 04FEFBH
13th byte	Data at address 04FEFCH
14th byte	Data at address 04FEFDH
15th byte	Data at address 04FEFEH
16th byte	Data at address 04FEFFH

Example of data that cannot be specified as a password

For blank products (Note)

- The password of a blank product must be all "FFH" (FFH, FFH, FFH, FFH, FFH, FFH, FFH, FFH, FFH, FFH, FFH, FFH).

Note: A blank product is a product in which all the bytes in the password area (addresses 04FEF4H to 04FEFFH) and the reset vector area (addresses 04FF00H to 04FF02H) are "FFH".

For programmed products

- The same 12 consecutive bytes cannot be specified as a password.

The table below shows password error examples.

Programmed product	1	2	3	4	5	6	7	8	9	10	11	12	Note
Error example 1	FFH	FFH	FFH	FFH	FFH	FFH	FFH	FFH	FFH	FFH	FFH	FFH	All "FF"
Error example 2	00H	00H	00H	00H	00H	00H	00H	00H	00H	00H	00H	00H	All "00"
Error example 3	5AH	5AH	5AH	5AH	5AH	5AH	5AH	5AH	5AH	5AH	5AH	5AH	All "5A"

3.14.4.17 How to Calculate SUM

SUM is calculated by summing the values of all data read from the flash memory by unsigned 8-bit addition and is returned as a word (16-bit) value. The resulting SUM value is sent to the controller in order of upper 8 bits and lower 8 bits. All the 256 Kbytes of data in the flash memory are included in the calculation of SUM. When the Flash Memory SUM command is executed, SUM is calculated in this way.

Example:

A1H
B2H
C3H
D4H

When SUM is calculated from the four data entries shown to the left, the result is as follows:

$$A1H + B2H + C3H + D4H = 02EAH$$

SUM upper 8 bits: 02H

SUM lower 8 bits: EAH

Thus, the SUM value is sent to the controller in order of 02H and EAH.

3.14.4.18 How to Calculate CHECKSUM

CHECKSUM is calculated by taking the two's complement of the lower 8-bit value obtained by summing the values of received data by unsigned 8-bit addition (ignoring any overflow). When the Flash Memory SUM command or the Product Information Read command is executed, CHECKSUM is calculated in this way. The controller should also use this CHECKSUM calculation method for sending CHECKSUM values.

Example: Calculating CHECKSUM for the Flash Memory SUM command

When the upper 8-bit data of SUM is E5H and the lower 8-bit data is F6H, CHECKSUM is calculated as shown below.

First, the upper 8 bits and lower 8 bits of the SUM value are added by unsigned operation.

$$E5H + F6H = 1DBH$$

Then, the two's complement of the lower 8 bits of this result is obtained as shown below. The resulting CHECKSUM value (25H) is sent to the controller.

$$0 - DBH = 25H$$

3.14.5 User Boot Mode (in Single Chip Mode)

User Boot mode, which is a sub mode of Single Chip mode, enables a user-created flash memory program/erase routine to be used. To do so, the operation mode of Single Chip mode must be changed from Normal mode for executing a user application program to User Boot mode for programming/erasing the flash memory.

For example, the reset processing routine of a user application program may include a routine for selecting Normal mode or User Boot mode upon entering Single Chip mode. Any mode-selecting condition may be set using the device's I/O to suit the user system.

To program/erase the flash memory in User Boot mode, a program/erase routine must be incorporated in the user application program in advance. Since the processor cannot read data from the internal flash memory while it is being programmed or erased, the program/erase routine must be executed from the outside of the flash memory. While the flash memory is being programmed/erased in User Boot mode, interrupts must be disabled.

The pages that follow explain the procedure for programming the flash memory using two example cases. In one case the program/erase routine is stored in the internal flash memory (1-A); in the other the program/erase routine is transferred from an external source (1-B).

Not Recommended for New Designs

3.14.5.1 (1-A) Program/Erase Procedure Example 1

When the program/erase routine is stored in the internal flash memory

(Step-1) Environment setup

First, the condition (e.g. pin status) for entering User Boot mode must be set and the I/O bus for transferring data must be determined. Then, the device's peripheral circuitry must be designed and a corresponding program must be written. Before mounting the device on the board, it is necessary to write the following four routines into one of the sectors in the flash memory.

- (a) Mode select routine : Selects Normal mode or User Boot mode.
- (b) Program/erase routine: Loads program/erase data from an external source and programs/erases the flash memory.
- (c) Copy routine 1 : Copies routines (a) to (d) into the internal RAM or external memory.
- (d) Copy routine 2 : Copies routines (a) to (d) from the internal RAM or external memory into the flash memory.

Note: The above (d) is a routine for reconstructing the program/erase routine on the flash memory. If the entire flash memory is always programmed and the program/erase routine is included in the new user application program, this copy routine is not needed.

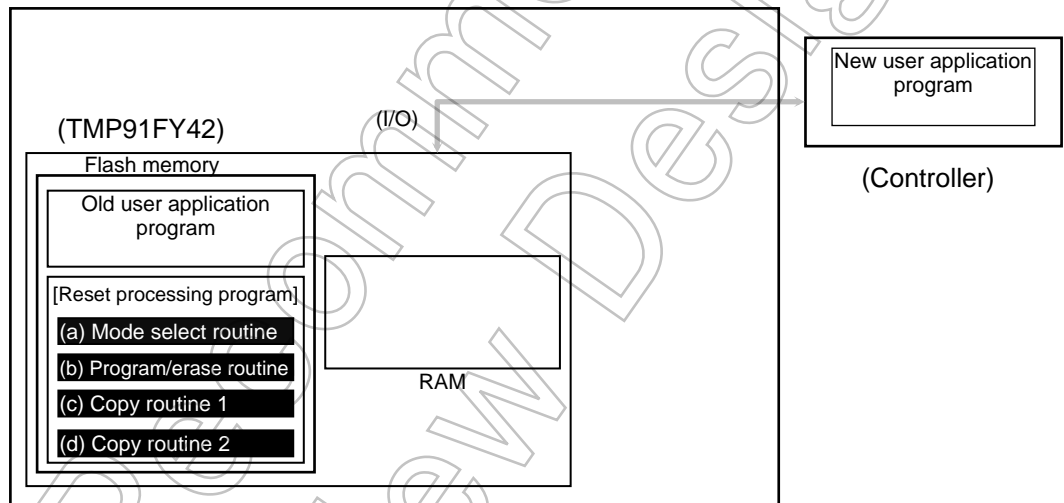

(Step-2) Entering User Boot mode (using the reset processing)

After reset release, the reset processing program determines whether or not the device should enter User Boot mode. If the condition for entering User Boot mode is true, User Boot mode is entered to program/erase the flash memory.

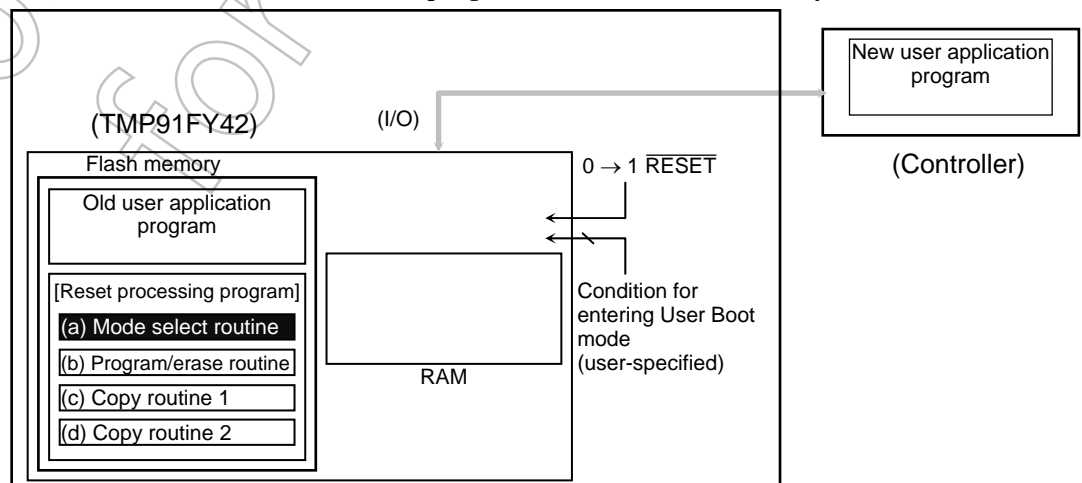

(Step-3) Copying the program/erase routine

After the device has entered User Boot mode, the copy routine 1 (c) copies the routines (a) to (d) into the internal RAM or external memory (The routines are copied into the internal RAM here.)

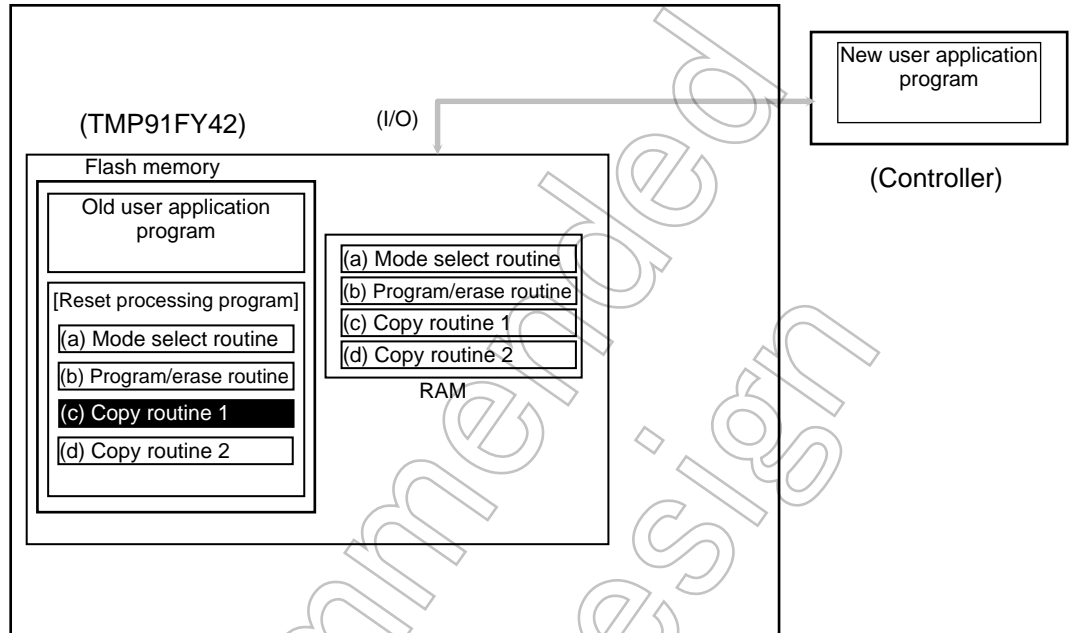

(Step-4) Erasing the flash memory by the program/erase routine

Control jumps to the program/erase routine in the RAM and the old user program area is erased (sector erase or chip erase). (In this case, the flash memory erase command is issued from the RAM.)

Note: If data is erased on a sector basis and the routines (a) to (d) are left in the flash memory, only the program/erase routine (b) need be copied into the RAM.

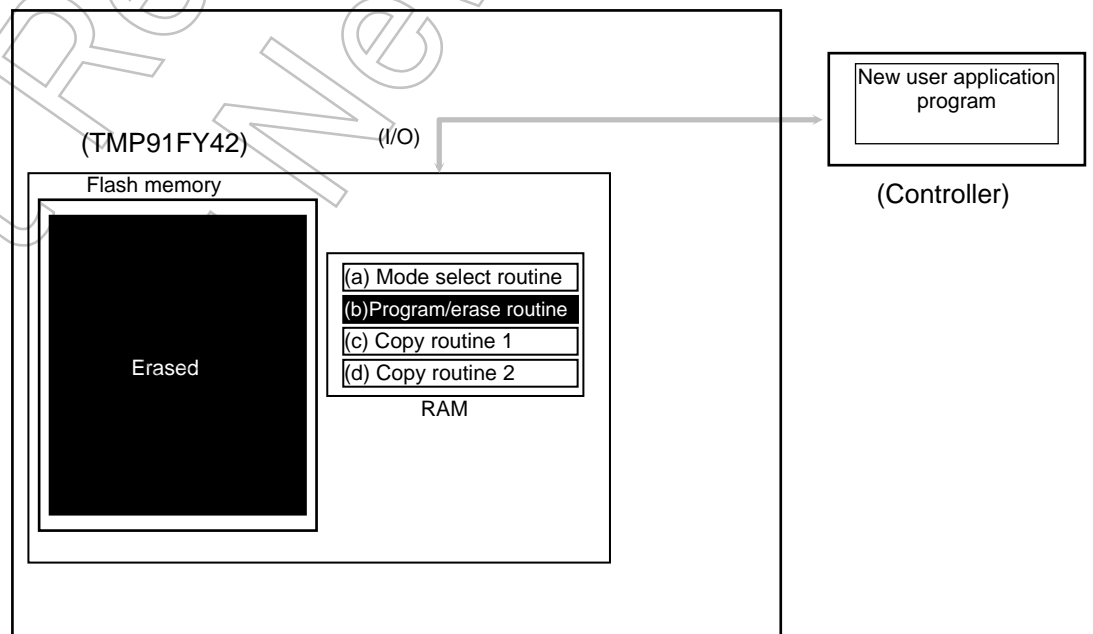

(Step-5) Restoring the user boot program in the flash memory

The copy routine 2 (d) in the RAM copies the routines (a) to (d) into the flash memory.

Note: If data is erased on a sector basis and the routines (a) to (d) are left in the flash memory, step 5 is not needed.

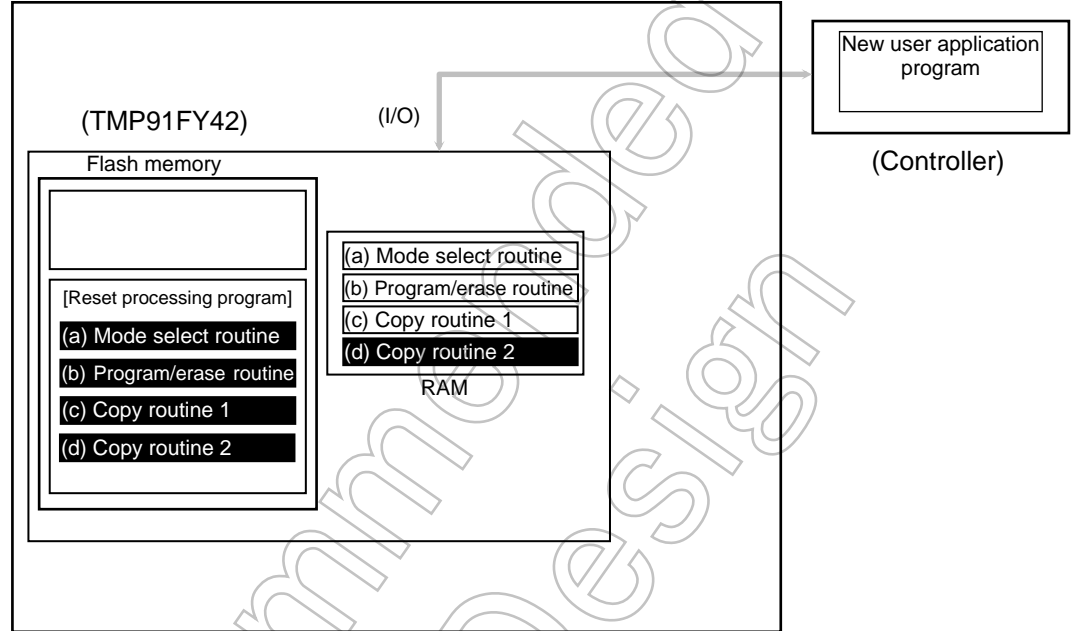

(Step-6) Writing the new user application program to the flash memory

The program/erase routine in the RAM is executed to load the new user application program from the controller into the erased area of the flash memory.

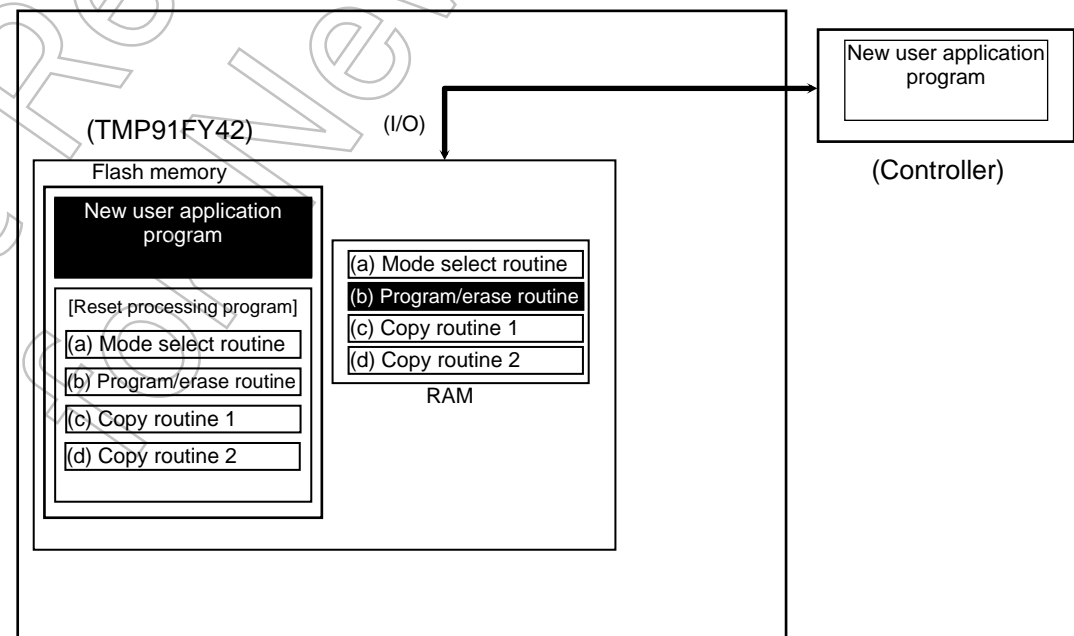

(Step-7) Executing the new user application program

The $\overline{\text{RESET}}$ input pin is driven Low ("0") to reset the device. The mode setting condition is set for Normal mode. After reset release, the device will start executing the new user application program.

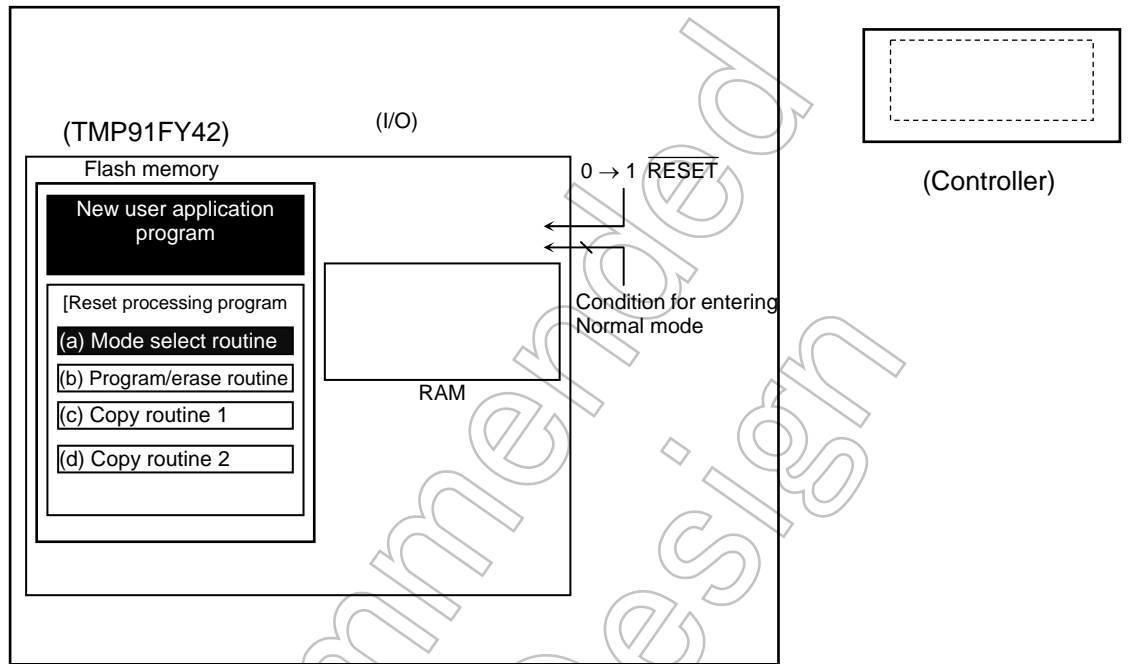

Not Recommended for New Design

3.14.5.2 (1-B) Program/Erase Procedure Example 2

In this example, only the boot program (minimum requirement) is stored in the flash memory and other necessary routines are supplied from the controller.

(Step-1) Environment setup

First, the condition (e.g. pin status) for entering User Boot mode must be set and the I/O bus for transferring data must be determined. Then, the device's peripheral circuitry must be designed and a corresponding program must be written. Before mounting the device on the board, it is necessary to write the following two routines into one on the sectors in the flash memory.

- (a) Mode select routine : Selects Normal mode or User Boot mode.
- (b) Transfer routine : Loads the program/erase routine from an external source.

The following routines are prepared on the controller.

- (c) Program/erase routine : Programs/erases the flash memory.
- (d) Copy routine 1 : Copies routines (a) and (b) into the internal RAM or external memory.
- (e) Copy routine 2 : Copies routines (a) and (b) from the internal RAM or external memory into the flash memory.

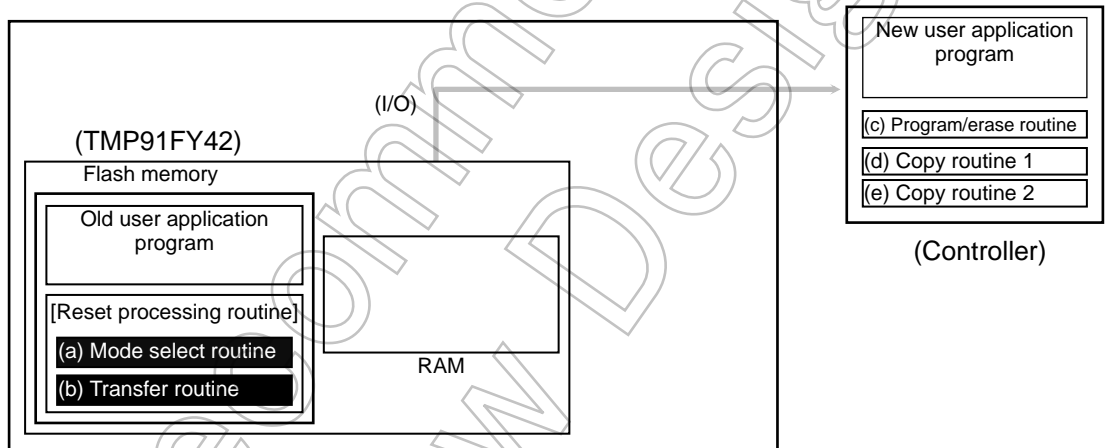

(Step-2) Entering User Boot mode (using the reset processing)

The following explanation assumes that these routines are incorporated in the reset processing program. After reset release, the reset processing program first determines whether or not the device should enter User Boot mode. If the condition for entering User Boot mode is true, User Boot mode is entered to program/erase the flash memory.

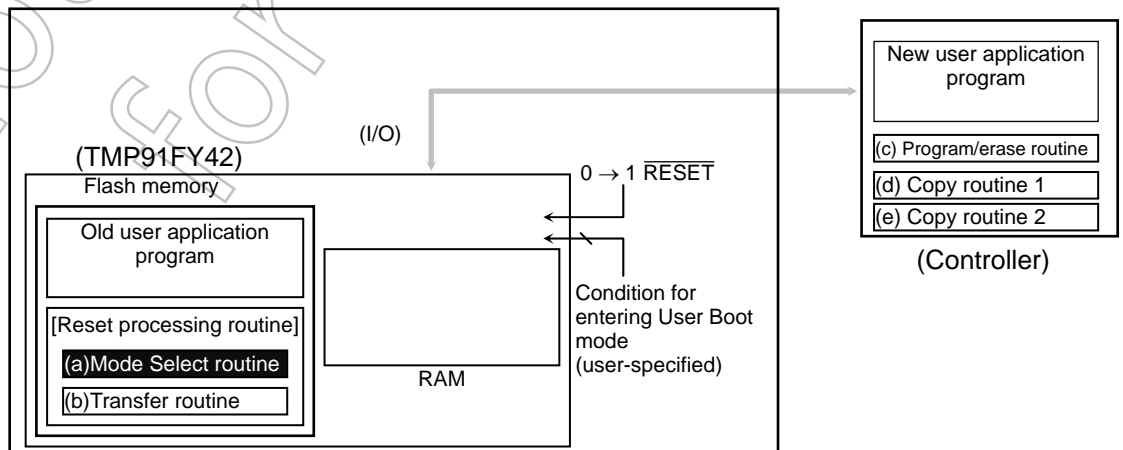

(Step-3) Copying the program/erase routine to the internal RAM

After the device has entered User Boot mode, the transfer routine (b) transfers the routines (c) to (e) from the controller to the internal RAM (or external memory). (The routines are copied into the internal RAM here.)

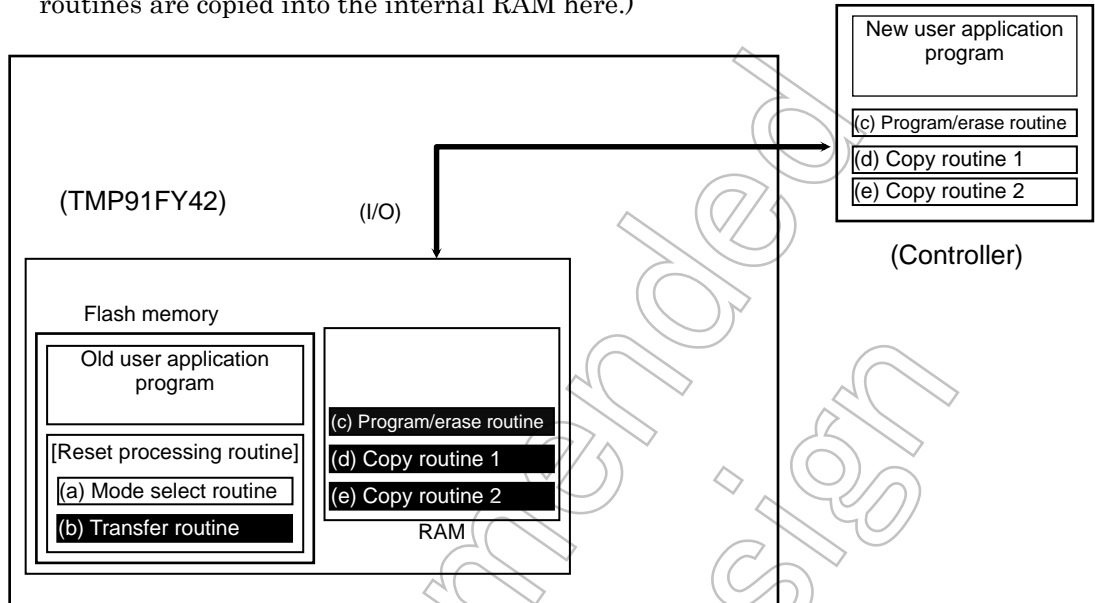

(Step-4) Executing the copy routine 1 in the internal RAM

Control jumps to the internal RAM and the copy routine 1 (d) copies the routines (a) and (b) into the internal RAM.

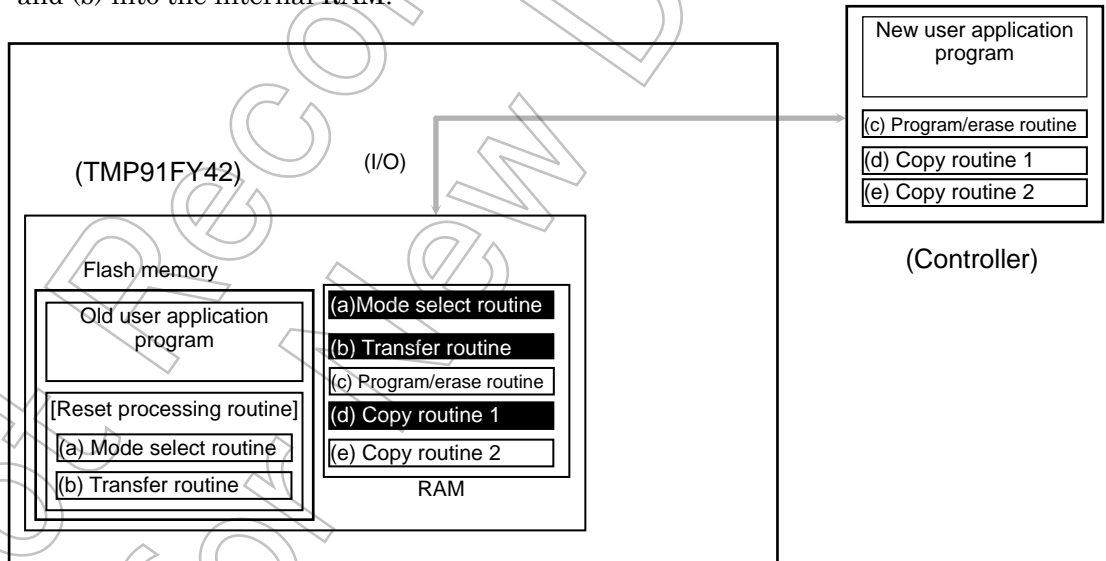

(Step-5) Erasing the flash memory by the program/erase routine

The program/erase routine (c) erases the old user program area.

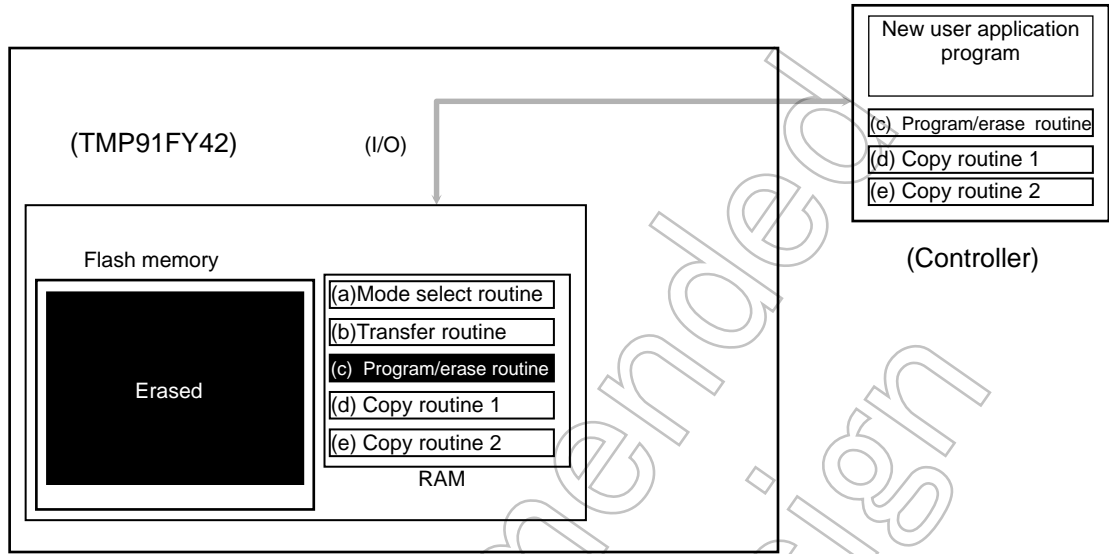

(Step-6) Restoring the user boot program in the flash memory

The copy routine (e) copies the routines (a) and (b) from the internal RAM into the flash memory.

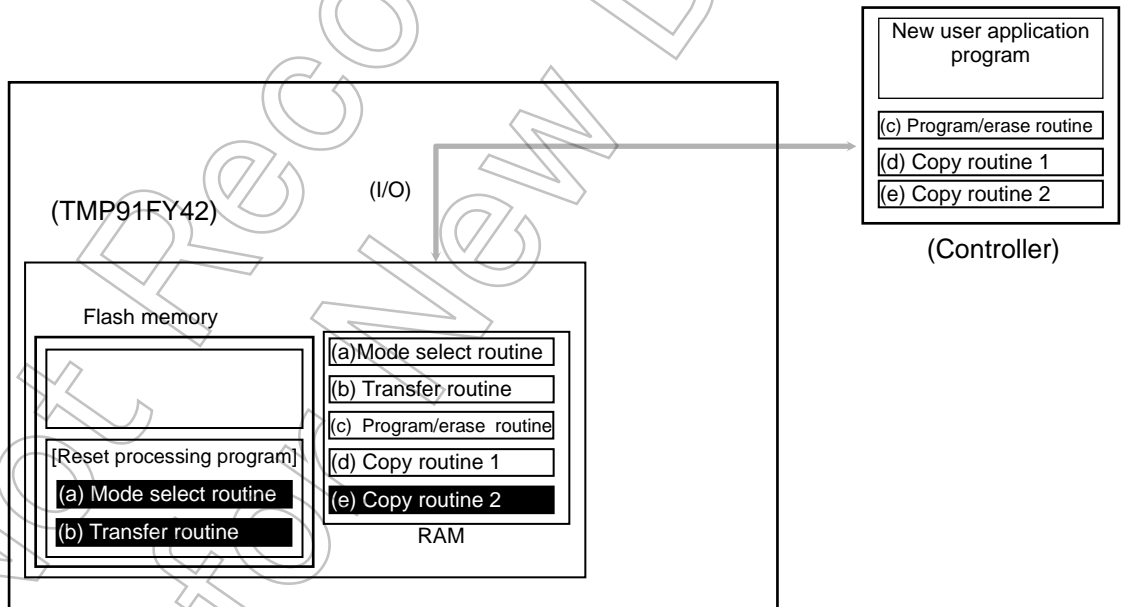

(Step-7) Writing the new user application program to the flash memory

The program/erase routine (c) in the RAM is executed to load the new user application program from the controller into the erased area of the flash memory.

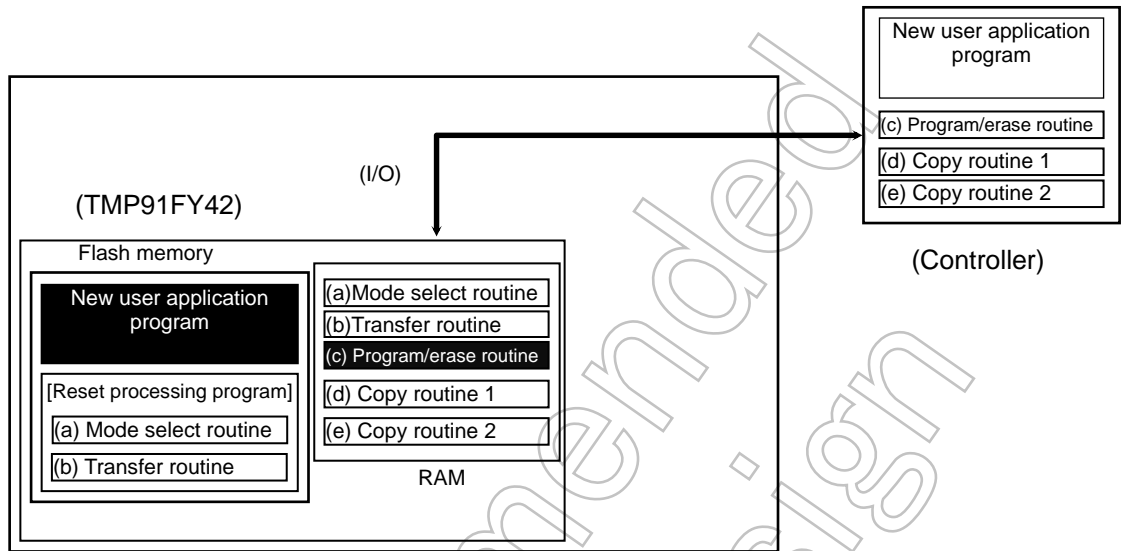

(Step-8) Executing the new user application program

The $\overline{\text{RESET}}$ input pin is driven Low ("0") to reset the device. The mode setting condition is set for Normal mode. After reset release, the device will start executing the new user application program.

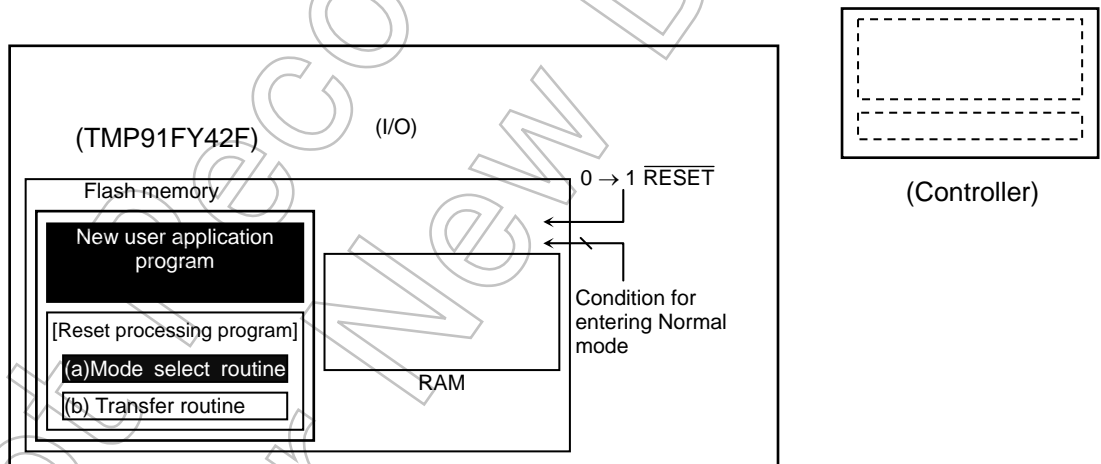

3.14.6 Flash Memory Command Sequences

The operation of the flash memory is comprised of six commands, as shown in Table 3.14.23. Addresses specified in each command sequence must be in an area where the flash memory is mapped. For details, see Table 3.14.3.

Table 3.14.23 Command Sequences

Command Sequence	1st Bus Write Cycle		2nd Bus Write Cycle		3rd Bus Write Cycle		4th Bus Write Cycle		5th Bus Write Cycle		6th Bus Write Cycle	
	Addr.	Data	Addr.	Data	Addr.	Data	Addr.	Data	Addr.	Data	Addr.	Data
1 Single Word Program	AAAH	AAH	554H	55H	AAAH	A0H	PA (Note 1)	PD (Note 1)				
2 Sector Erase (4-KB Erase)	AAAH	AAH	554H	55H	AAAH	80H	AAAH	AAH	554H	55H	SA (Note 2)	30H
3 Chip Erase (All Erase)	AAAH	AAH	554H	55H	AAAH	80H	AAAH	AAH	554H	55H	AAAH	10H
4 Product ID Entry	AAAH	AAH	554H	55H	AAAH	90H						
5 Product ID Exit	xxH	F0H										
	AAAH	AAH	554H	55H	AAAH	F0H						
6 Read Protect Set	AAAH	AAH	554H	55H	AAAH	A5H	77EH	F0H (Note3)				
	AAAH	AAH	554H	55H	AAAH	A5H	77EH	0FH (Note3)				

Note 1: PA = Program Word address, PD = Program Word data

Set the address and data to be programmed. Even-numbered addresses should be specified here.

Note 2: SA = Sector Erase address, Each sector erase range is selected by address A23 to A12.

Note 3: When apply read protect and write protect, be sure to program the data of 00H.

Table 3.14.24 Hardware Sequence Flags

Status	D7	D6
Single Word Program	$\overline{D7}$	Toggle
During auto operation Sector Erase/Chip Erase	0	Toggle
Read Protect Set/Write Protect Set	Cannot be used	Toggle

Note: D15 to D8 and D5 to D0 are "don't care".

3.14.6.1 Single Word Program

The Single Word Program command sequence programs the flash memory on a word basis. The address and data to be programmed are specified in the 4th bus write cycle. It takes a maximum of 60 μ s to program a single word. Another command sequence cannot be executed until the write operation has completed. This can be checked by reading the same address in the flash memory repeatedly until the same data is read consecutively. While a write operation is in progress, bit 6 of data is toggled each time it is read.

Note: To rewrite data to Flash memory addresses at which data (including FFFFH) is already written, make sure to erase the existing data by "sector erase" or "chip erase" before rewriting data.

3.14.6.2 Sector Erase (4-Kbyte Erase)

The Sector Erase command sequence erases 4 Kbytes of data in the flash memory at a time. The flash memory address range to be erased is specified in the 6th bus write cycle. For the address range of each sector, see Table 3.14.3. This command sequence cannot be used in Programmer mode.

It takes a maximum of 75 ms to erase 4 Kbytes. Another command sequence cannot be executed until the erase operation has completed. This can be checked by reading the same address in the flash memory repeatedly until the same data is read consecutively. While a erase operation is in progress, bit 6 of data is toggled each time it is read.

3.14.6.3 Chip Erase (All Erase)

The Chip Erase command sequence erases the entire area of the flash memory.

It takes a maximum of 300 ms to erase the entire flash memory. Another command sequence cannot be executed until the erase operation has completed. This can be checked by reading the same address in the flash memory repeatedly until the same data is read consecutively. While a erase operation is in progress, bit 6 of data is toggled each time it is read.

Erase operations clear data to FFH.

3.14.6.4 Product ID Entry

When the Product ID Entry command is executed, Product ID mode is entered. In this mode, the vendor ID, flash macro ID, flash size ID, and read/write protect status can be read from the flash memory. In Product ID mode, the data in the flash memory cannot be read.

3.14.6.5 Product ID Exit

This command sequence is used to exit Product ID mode.

3.14.6.6 Read Protect Set

The Read Protect Set command sequence applies read protection on the flash memory. When read protection is applied, the flash memory cannot be read in Programmer mode and the RAM Transfer and Flash Memory Program commands cannot be executed in Single Boot mode.

To cancel read protection, it is necessary to execute the Chip Erase command sequence. To check whether or not read protection is applied, read xxx77EH in Product ID mode. It takes a maximum of 60 μ s to set read protection on the flash memory. Another command sequence cannot be executed until the read protection setting has completed. This can be checked by reading the same address in the flash memory repeatedly until the same data can be read consecutively. While a read protect operation is in progress, bit 6 of data is toggled each time it is read.

3.14.6.7 Write Protect Set

The Write Protect Set command sequence applies write protection on the flash memory. When write protection is applied, the flash memory cannot be written to in Programmer mode and the RAM Transfer and Flash Memory Program commands cannot be executed in Single Boot mode.

To cancel write protection, it is necessary to execute the Chip Erase command sequence. To check whether or not write protection is applied, read xxx77EH in Product ID mode. It takes a maximum of 60 μ s to set write protection. Another command sequence cannot be executed until the write protection setting has completed. This can be checked by reading the same address in the flash memory repeatedly until the same data can be read consecutively. While a write protect operation is in progress, bit 6 of data is toggled each time it is read.

3.14.6.8 Hardware Sequence Flags

The following hardware sequence flags are available to check the auto operation execution status of the flash memory.

1) Data polling (D7)

When data is written to the flash memory, D7 outputs the complement of its programmed data until the write operation has completed. After the write operation has completed, D7 outputs the proper cell data. By reading D7, therefore, the operation status can be checked. While the Sector Erase or Chip Erase command sequence is being executed, D7 outputs "0". After the command sequence is completed, D7 outputs "1" (cell data). Then, the data written to all the bits can be read after waiting for 1 μ s.

When read/write protection is applied, the data polling function cannot be used. Instead, use the toggle bit (D6) to check the operation status.

2) Toggle bit (D6)

When the Flash Memory Program, Sector Erase, Chip Erase, Write Protect Set, or Read Protect Set command sequence is executed, bit 6 (D6) of the data read by read operations outputs “0” and “1” alternately each time it is read until the processing of the executed command sequence has completed. The toggle bit (D6) thus provides a software means of checking whether or not the processing of each command sequence has completed. Normally, the same address in the flash memory is read repeatedly until the same data is read successively. The initial read of the toggle bit always returns “1”.

Note: The flash memory incorporated in the TMP91FY42 does not have an exceed-time-limit bit (D5). It is therefore necessary to set the data polling time limit and toggle bit polling time limit so that polling can be stopped if the time limit is exceeded.

3.14.6.9 Data Read

Data is read from the flash memory in byte units or word units. It is not necessary to execute a command sequence to read data from the flash memory.

Not Recommended
for New Design

3.14.6.10 Programming the Flash Memory by the Internal CPU

The internal CPU programs the flash memory by using the command sequences and hardware sequence flags described above. However, since the flash memory cannot be read during auto operation mode, the program/erase routine must be executed outside of the flash memory.

The CPU can program the flash memory either by using Single Boot mode or by using a user-created protocol in Single Chip mode (User Boot).

1) Single Boot:

The microcontroller is started up in Single Boot mode to program the flash memory by the internal boot ROM program. In this mode, the internal boot ROM is mapped to an area including the interrupt vector table, in which the boot ROM program is executed. The flash memory is mapped to an address area different from the boot ROM area. The boot ROM program loads data into the flash memory by serial transfer. In Single Boot mode, interrupts must be disabled including non-maskable interrupts (NMI, etc.).

For details, see 3.14.4 “Single Boot Mode”

2) User Boot:

In this method, the flash memory is programmed by executing a user-created routine in Single Chip mode (normal operation mode). In this mode, the user-created program/erase routine must also be executed outside of the flash memory. It is also necessary to disable interrupts including non-maskable interrupts.

The user should prepare a flash memory program/erase routine (including routines for loading write data and writing the loaded data into the flash memory). In the main program, normal operation is switched to flash memory programming operation to execute the flash memory program/erase routine outside of the flash memory area. For example, the flash memory program/erase routine may be transferred from the flash memory to the internal RAM and executed there or it may be prepared and executed in external memory.

For details, see 3.14.5 “User Boot Mode (in Single Chip Mode)”

Flowcharts: Flash memory access by the internal CPU

Single Word Program

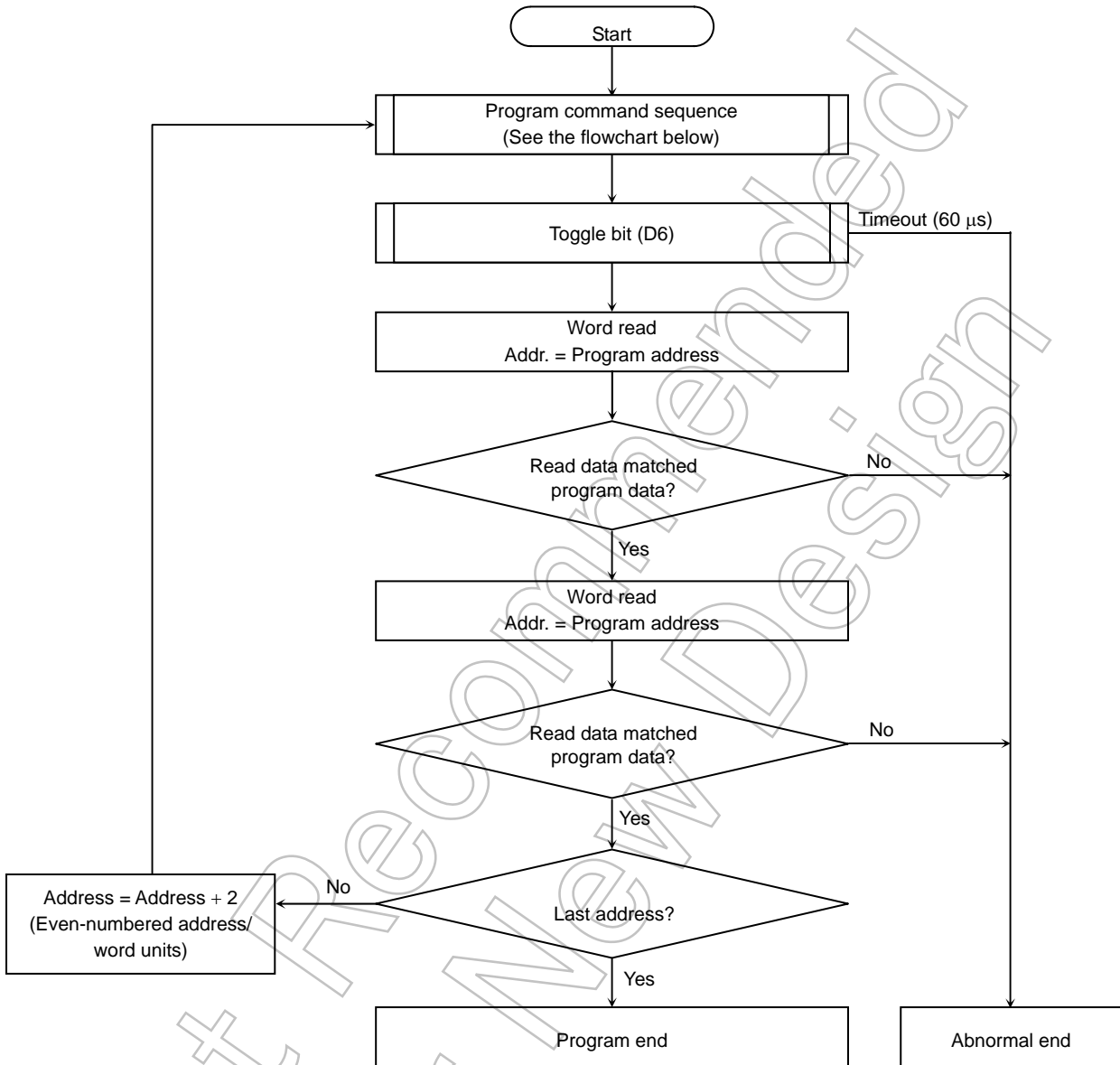

Program Command Sequence (Address/Data)

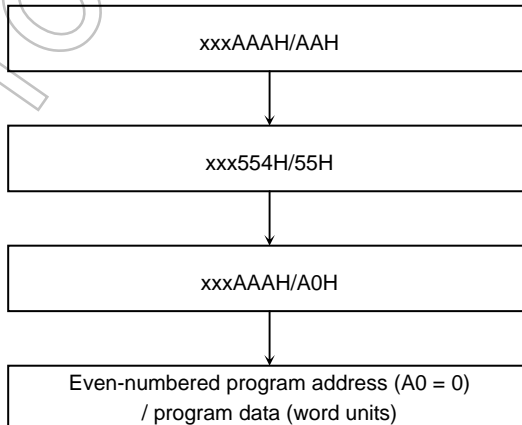

Chip Erase/Sector Erase

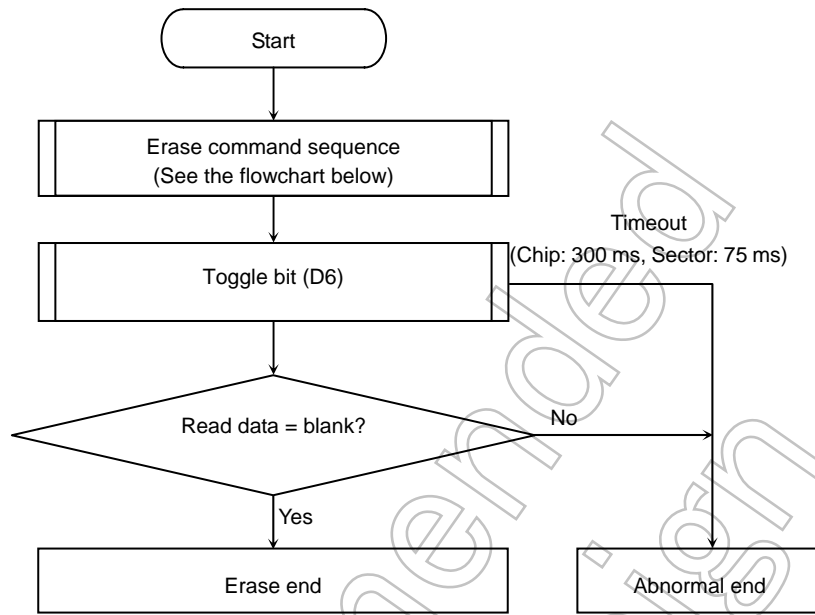

Note: In Chip Erase, whether or not the entire flash memory is blank is checked.
 In Sector Erase, whether or not the selected sector is blank is checked.

Chip Erase Command Sequence
(Address/Data)

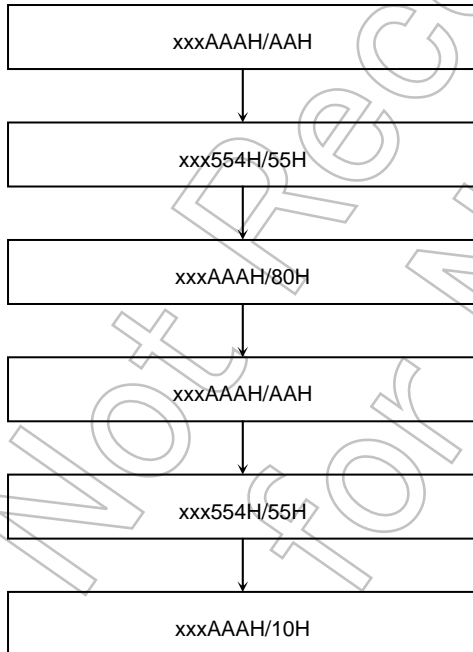

Sector Erase Command Sequence
(Address/Data)

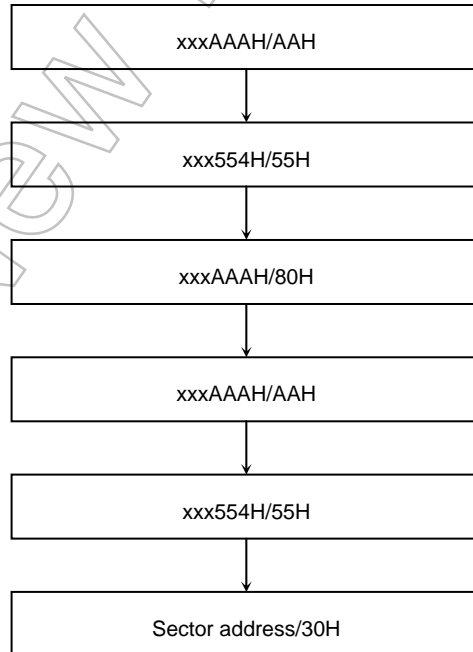

Read/Write Protect Set

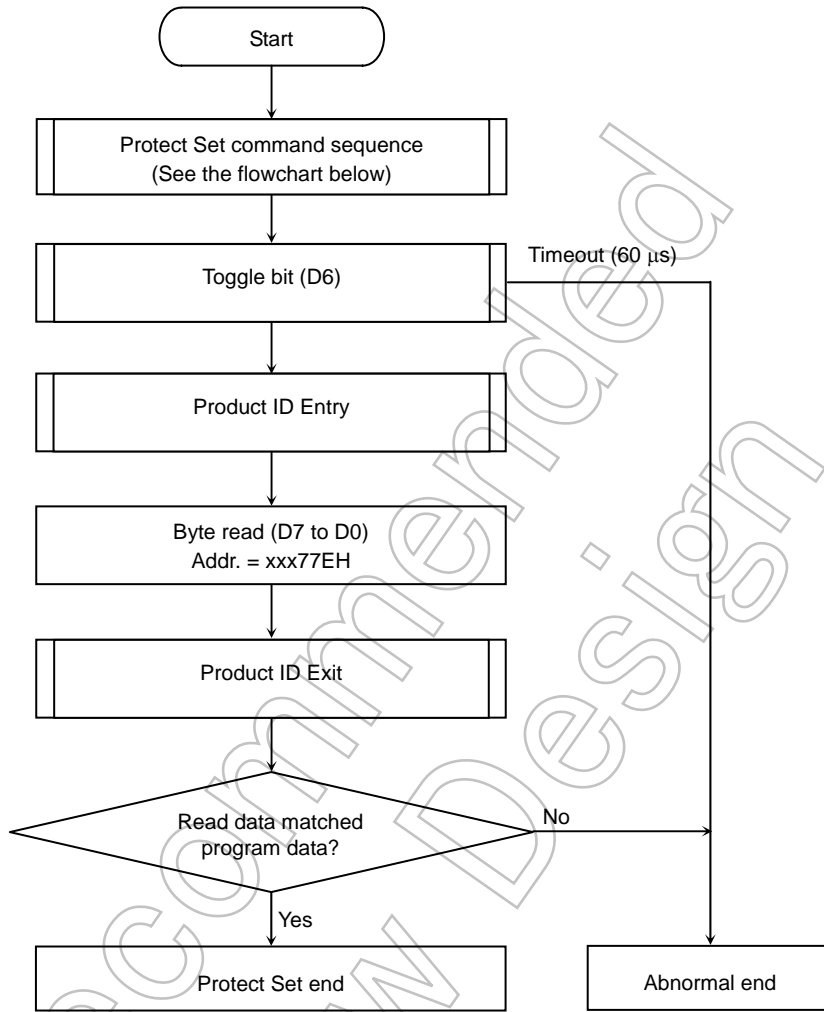

Protect Set Command Sequence
(Address/Data)

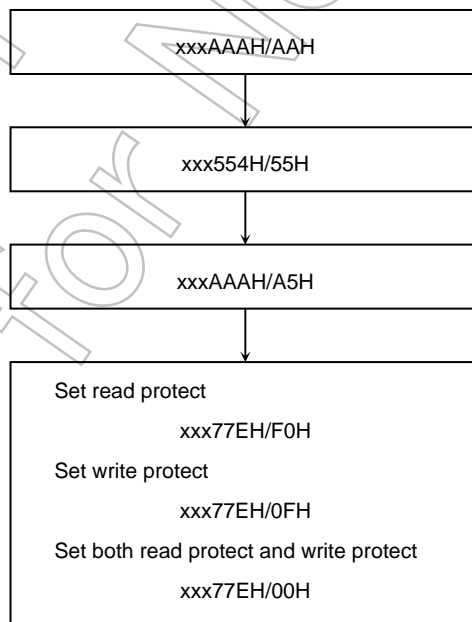

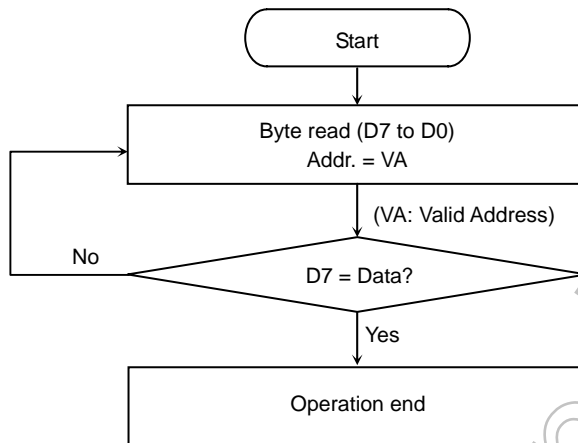
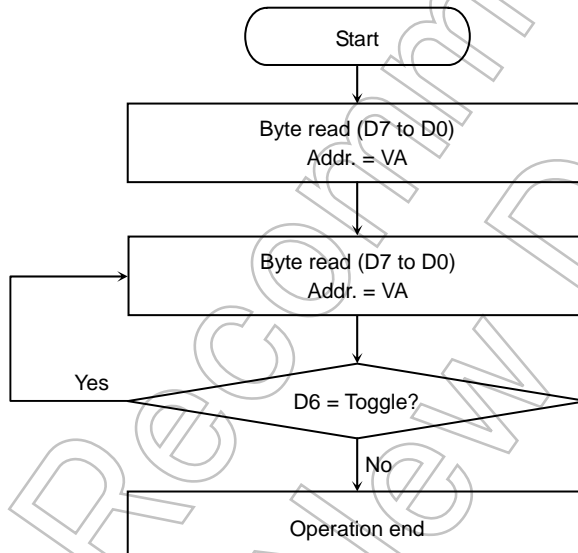
Data Polling (D7)Toggle Bit (D6)

Note: Hardware sequence flags are read from the flash memory in byte units or word units.

VA: In Single Word Program, VA denotes the address to be programmed.
 In Sector Erase, VA denotes any address in the selected sector.
 In Chip Erase, VA denotes any address in the flash memory.
 In Read Protect Set, VA denotes the protect set address (xx77EH).
 In Write Protect Set, VA denotes the protect set address (xx77EH).

Product ID Entry

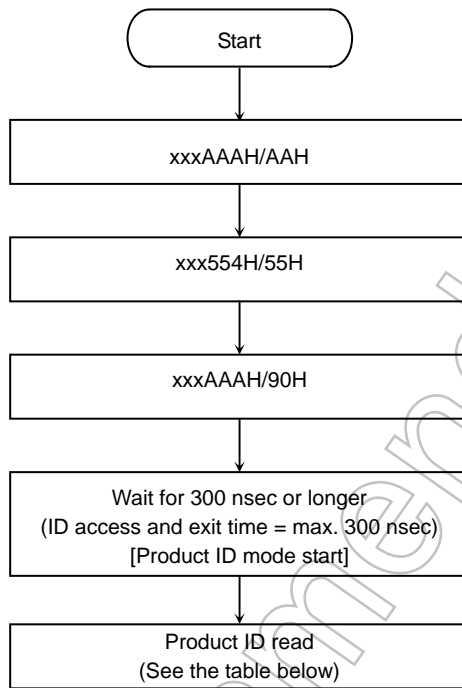

Read Values in Product ID Mode

	Address	Read Value
Vendor ID	xxx00H	98H
Flash macro ID	xxx02H	42H
Flash size ID	xxx04H	3FH
Read/Write Protect status	xxx77EH	Data programmed when protection is set. When protection is not set, FFH.

Product ID Exit

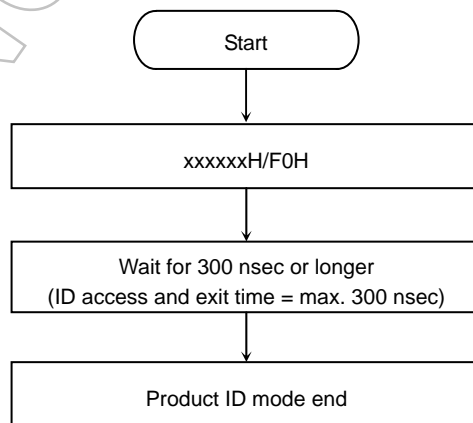
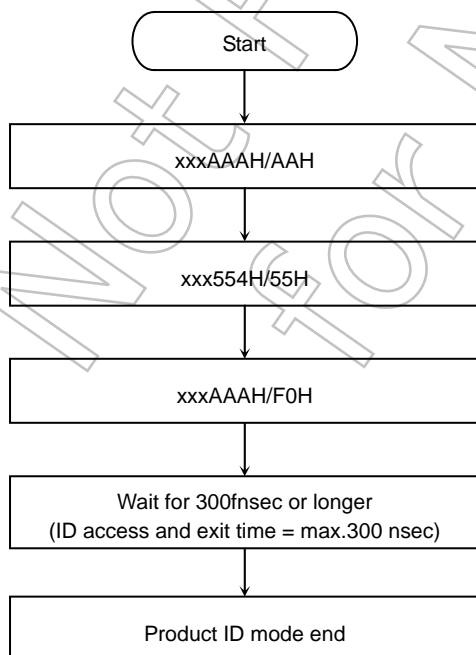

(Example: Program to be loaded and executed in RAM)

Erase the flash memory (chip erase) and then write 0706H to address 10000H.

```

##### Flash memory chip erase processing #####
ld      XIX, 0x10000      ; set start address
CHIPERASE:
ld      (0x10AAA), 0xAA      ; 1st bus write cycle
ld      (0x10554), 0x55      ; 2nd bus write cycle
ld      (0x10AAA), 0x80      ; 3rd bus write cycle
ld      (0x10AAA), 0xAA      ; 4th bus write cycle
ld      (0x10554), 0x55      ; 5th bus write cycle
ld      (0x10AAA), 0x10      ; 6th bus write cycle

cal     TOGGLECHK          ; check toggle bit

CHIPERASE_LOOP:
ld      WA, (XIX+)          ; read data from flash memory
cp      WA, 0xFFFF          ; blank data?
j       ne, CHIPERASE_ERR   ; if not blank data, jump to error processing
cp      XIX, 0x4FFFF        ; end address (0x4FFFF)?
j       j, CHIPERASE_LOOP   ; check entire memory area and then end loop processing

##### Flash memory program processing #####
ld      XIX, 0x10000      ; set program address
ld      WA, 0x0706         ; set program data
PROGRAM:
ld      (0x10AAA), 0xAA      ; 1st bus write cycle
ld      (0x10554), 0x55      ; 2nd bus write cycle
ld      (0x10AAA), 0xA0      ; 3rd bus write cycle
ld      (XIX), WA           ; 4th bus write cycle
cal     TOGGLECHK          ; check toggle bit

ld      BC, (XIX)           ; read data from flash memory
cp      WA, BC              ;
j       ne, PROGRAM_ERR     ; if programmed data cannot be read, error is determined
ld      BC, (XIX)           ; read data from flash memory
cp      WA, BC              ;
j       ne, PROGRAM_ERR     ; if programmed data cannot be read, error is determined

PROGRAM_END:
j       PROGRAM_END        ; program operation end

##### Toggle bit (D6) check processing #####
TOGGLECHK:
ld      L, (XIX)           ;
and     L, 0y01000000      ; check toggle bit (D6)
ld      H, L                ; save first toggle bit data
TOGGLECHK1:
ld      L, (XIX)           ;
and     L, 0y01000000      ; check toggle bit (D6)
cp      L, H                ; toggle bit = toggled?
j       z, TOGGLECHK2       ; if not toggled, end processing
ld      H, L                ; save current toggle bit state
j       j, TOGGLECHK1       ; recheck toggle bit
TOGGLECHK2:
ret

##### Error processing #####
CHIPERASE_ERR:
j       CHIPERASE_ERR       ; chip erase error

PROGRAM_ERR:
j       PROGRAM_ERR         ; program error

```

(Example: Program to be loaded and executed in RAM)

Erase data at addresses 20000H to 20FFFH (sector erase) and then write 0706H to address 20000H.

```

##### Flash memory sector erase processing #####
ld      XIX, 0x20000          ; set start address
SECTORERASE:
ld      (0x10AAA), 0xAA      ; 1st bus write cycle
ld      (0x10554), 0x55      ; 2nd bus write cycle
ld      (0x10AAA), 0x80      ; 3rd bus write cycle
ld      (0x10AAA), 0xAA      ; 4th bus write cycle
ld      (0x10554), 0x55      ; 5th bus write cycle
ld      (XIX), 0x30          ; 6th bus write cycle

cal     TOGGLECHK           ; check toggle bit

SECTORERASE_LOOP:
ld      WA, (XIX+)          ; read data from flash memory
cp      WA, 0xFFFF          ; blank data?
j       ne, SECTORERASE_ERR ; if not blank data, jump to error processing
cp      XIX, 0x20FFF         ; end address (0x20FFF)?
j       ult, SECTORERASE_LOOP ; check erased sector area and then end loop processing

##### Flash memory program processing #####
ld      XIX, 0x20000          ; set program address
ld      WA, 0x0706           ; set program data
PROGRAM:
ld      (0x10AAA), 0xAA      ; 1st bus write cycle
ld      (0x10554), 0x55      ; 2nd bus write cycle
ld      (0x10AAA), 0xA0      ; 3rd bus write cycle
ld      (XIX), WA           ; 4th bus write cycle

cal     TOGGLECHK           ; check toggle bit

ld      BC, (XIX)           ; read data from flash memory
cp      WA, BC              ; if programmed data cannot be read, error is determined
j       ne, PROGRAM_ERR
ld      BC, (XIX)           ; read data from flash memory
cp      WA, BC              ; if programmed data cannot be read, error is determined
j       ne, PROGRAM_ERR

PROGRAM_END:
j       PROGRAM_END        ; program operation end

##### Toggle bit (D6) check processing #####
TOGGLECHK:
ld      L, (XIX)
and     L, 0y01000000        ; check toggle bit (D6)
ld      H, L                 ; save first toggle bit data
TOGGLECHK1:
ld      L, (XIX)
and     L, 0y01000000        ; check toggle bit (D6)
cp      L, H                 ; toggle bit = toggled?
j       z, TOGGLECHK2        ; If not toggled, end processing
ld      H, L                 ; save current toggle bit state
j       TOGGLECHK1          ; Recheck toggle bit
TOGGLECHK2:
ret

##### Error processing #####
SECTORERASE_ERR:
j       SECTORERASE_ERR     ; sector erase error

PROGRAM_ERR:
j       PROGRAM_ERR        ; program error

```

(Example: Program to be loaded and executed in RAM)

Set read protection and write protection on the flash memory.

```

##### Flash Memory Protect Set processing #####
ld      XIX, 0x1077E          ; set protect address
PROTECT:
ld      (0x10AAA), 0xAA      ; 1st bus write cycle
ld      (0x10554), 0x55      ; 2nd bus write cycle
ld      (0x10AAA), 0xA5      ; 3rd bus write cycle
ld      (XIX), 0x00          ; 4th bus write cycle

cal     TOGGLECHK            ; check toggle bit
cal     PID_ENTRY            ;
ld      A, (XIX)             ; read protected address
cal     PID_EXIT             ;
cp      A, 0x00              ; (0x1077E)=0x00?
j       ne, PROTECT_ERR      ; protected?

PROTECT_END:
j       PROTECT_END          ; protect set operation completed

PROTECT_ERR:
j       PROTECT_ERR          ; protect set error

##### Product ID Entry processing #####
PID_ENTRY:
ld      (0x10AAA), 0xAA      ; 1st bus write cycle
ld      (0x10554), 0x55      ; 2nd bus write cycle
ld      (0x10AAA), 0x90      ; 3rd bus write cycle
; --- wait for 300 nsec or longer (execute NOP instruction [148nsec/@fPPH=27MHz] three times) ---
nop
nop
nop
; wait for 444 nsec
ret

##### Product ID Exit processing #####
PID_EXIT:
ld      (0x10000), 0xF0      ; 1st bus write cycle
; --- wait for 300 nsec or longer (execute NOP instruction [148nsec/@fPPH=27MHz] three times) ---
nop
nop
nop
; wait for 444 nsec
ret

##### Toggle bit (D6) check processing #####
TOGGLECHK:
ld      L, (XIX)
and     L, 0y01000000        ; check toggle bit (D6)
ld      H, L                  ; save first toggle bit data
TOGGLECHK1:
ld      L, (XIX)
and     L, 0y01000000        ; check toggle bit (D6)
cp      L, H                  ; toggle bit = toggled?
j       z, TOGGLECHK2        ; if not toggled, end processing
ld      H, L                  ; save current toggle bit state
j       TOGGLECHK1           ; recheck toggle bit
TOGGLECHK2:
ret

```

(Example: Program to be loaded and executed in RAM)

Read data from address 10000H.

```

##### Flash memory read processing #####
READ:
ld      WA, (0x10000)        ; read data from flash memory

```

4. Electrical Characteristics

4.1 Absolute Maximum Ratings

Parameter	Symbol	Rating	Unit
Power supply voltage	V _{CC}	-0.5 to 4.0	V
Input voltage	V _{IN}	-0.5 to V _{CC} + 0.5	
Output current	I _{OL}	2	mA
Output current	I _{OH}	-2	
Output current (total)	ΣI _{OL}	80	
Output current (total)	ΣI _{OH}	-80	
Power dissipation (T _a = 85°C)	PD	600	mW
Soldering temperature (10 s)	TSOLDER	260	°C
Storage temperature	TSTG	-65 to 150	
Operating temperature	TOPR	-40 to 85	
Number of Times Program Erase	N _{EW}	100	Cycle

Note: The absolute maximum ratings are rated values which must not be exceeded during operation, even for an instant. Any one of the ratings must not be exceeded. If any absolute maximum rating is exceeded, a device may break down or its performance may be degraded, causing it to catch fire or explode resulting in injury to the user. Thus, when designing products which include this device, ensure that no absolute maximum rating value will ever be exceeded.

Solderability of lead free products

Test parameter	Test condition	Note
Solderability	(1) Use of Sn-37Pb solder Bath Solder bath temperature = 230°C, Dipping time = 5 seconds The number of times = one, Use of R-type flux	Pass: solderability rate until forming ≥ 95%
	(2) Use of Sn-3.0Ag-0.5Cu solder bath Solder bath temperature = 245°C, Dipping time = 5 seconds The number of times = one, Use of R-type flux (use of lead free)	

4.2 DC Characteristics (1/2)

Parameter		Symbol	Condition		Min	Typ. (Note)	Max	Unit
Power Supply Voltage ($A_{Vcc} = DV_{cc}$ $A_{Vss} = DV_{ss} = 0\text{ V}$)		VCC	$f_c = 4$ to 27 MHz	$f_s = 30$ to 34 kHz	2.7		3.6	V
Power Supply Voltage ($A_{Vcc} = DV_{cc}$ $A_{Vss} = DV_{ss} = 0\text{ V}$) for erase/program operations of flash memory		VCC	$f_c = 4$ to 27 MHz $T_a = -10\sim 40^\circ\text{C}$		3.0		3.6	V
Input Low Voltage	P00~P17 (AD0~15)	VIL	$V_{cc} = 2.7\text{V}\sim 3.6\text{V}$				0.6	V
	P20~PA7 (Except P63)	VIL1	$V_{cc} = 2.7\text{V}\sim 3.6\text{V}$				$0.3 V_{cc}$	
	$\overline{\text{RESET}}$, $\overline{\text{NMI}}$, P63 (INT0)	VIL2	$V_{cc} = 2.7\text{V}\sim 3.6\text{V}$		-0.3		$0.25 V_{cc}$	
	AM0~1	VIL3	$V_{cc} = 2.7\text{V}\sim 3.6\text{V}$				0.3	
	X1	VIL4	$V_{cc} = 2.7\text{V}\sim 3.6\text{V}$				$0.2 V_{cc}$	
Input High Voltage	P00~P17 (AD0~15)	VIH	$V_{cc} = 2.7\text{V}\sim 3.6\text{V}$		2.0			V
	P20~PA7 (Except P63)	VIH1	$V_{cc} = 2.7\text{V}\sim 3.6\text{V}$		$0.7V_{cc}$			
	$\overline{\text{RESET}}$, $\overline{\text{NMI}}$, P63 (INT0)	VIH2	$V_{cc} = 2.7\text{V}\sim 3.6\text{V}$		$0.75V_{cc}$		$V_{cc} + 0.3$	
	AM0~1	VIH3	$V_{cc} = 2.7\text{V}\sim 3.6\text{V}$		$V_{cc} - 0.3$			
	X1	VIH4	$V_{cc} = 2.7\text{V}\sim 3.6\text{V}$		$0.8V_{cc}$			
Output Low Voltage	VOL	$I_{OL} = 1.6\text{mA}$	$V_{cc} = 2.7\text{V}\sim 3.6\text{V}$				0.45	V
Output High Voltage	VOH	$I_{OH} = -400\mu\text{A}$	$V_{cc} = 2.7\text{V}\sim 3.6\text{V}$		$V_{cc} - 0.3$			

Note: Typical values are for when $T_a = 25^\circ\text{C}$ and $V_{cc} = 3.0\text{ V}$ unless otherwise noted.

4.2 DC Characteristics (2/2)

Parameter	Symbol	Condition	Min	Typ. (Note1)	Max	Unit
Input Leakage Current	ILI	$0.0 \leq V_{IN} \leq V_{CC}$		0.02	± 5	μA
Output Leakage Current	ILO	$0.2 \leq V_{IN} \leq V_{CC} - 0.2$		0.05	± 10	
Power Down Voltage (@STOP, RAM Back up)	VSTOP	$V_{IL2} = 0.2 V_{CC}$, $V_{IH2} = 0.8 V_{CC}$	2.7		3.6	V
\overline{RESET} Pull Up Resistor	RRST	$V_{CC} = 2.7V \sim 3.6 V$	80		400	k Ω
Pin Capacitance	CIO	$F_c = 1 \text{ MHz}$			10	pF
Schmitt Width \overline{RESET} , \overline{NMI} , $\overline{INT0}$	VTH	$V_{CC} = 2.7V \sim 3.6V$	0.4	1.0		V
Programmable Pull Up Resistor	RKH	$V_{CC} = 2.7V \sim 3.6 V$	80		400	k Ω
NORMAL (Note 2)	Icc	$V_{CC} = 2.7V \sim 3.6 V$ $f_c = 27 \text{ MHz}$		19	30	mA
IDLE2				3.6	8.0	
IDLE1				1.0	4.0	
SLOW (Note 2)	Icc	$V_{CC} = 2.7V \sim 3.6 V$ $f_s = 32.768 \text{ kHz}$		21.0	60	μA
IDLE2				9.0	50	
IDLE1				6.0	40	
STOP		$V_{CC} = 2.7V \sim 3.6 V$		1.0	25	μA
Peak current by intermitt operation	Iccp-p	$V_{CC} = 2.7V \sim 3.6 V$		20		mA

Note 1: Typical values are for when $T_a = 25^\circ C$ and $V_{CC} = 3.0 V$ unless otherwise noted.

Note 2: Icc measurement conditions (NORMAL, SLOW):

All functions are operating; output pins are open and input pins are fixed.

When the program is operating by the flash memory, or when data read from the flash memory, the flash memory operate intermittently. Therefore, it outputs a peak current like a following diagram, momentarily. In this case, the power supply current; Icc (NORMAL/SLOW mode) is the sum of average value of a peak current and a MCU current.

When designing the power supply, set to a circuit which a peak current can be supplied. In SLOW mode, a defference of peak current and average current is large.

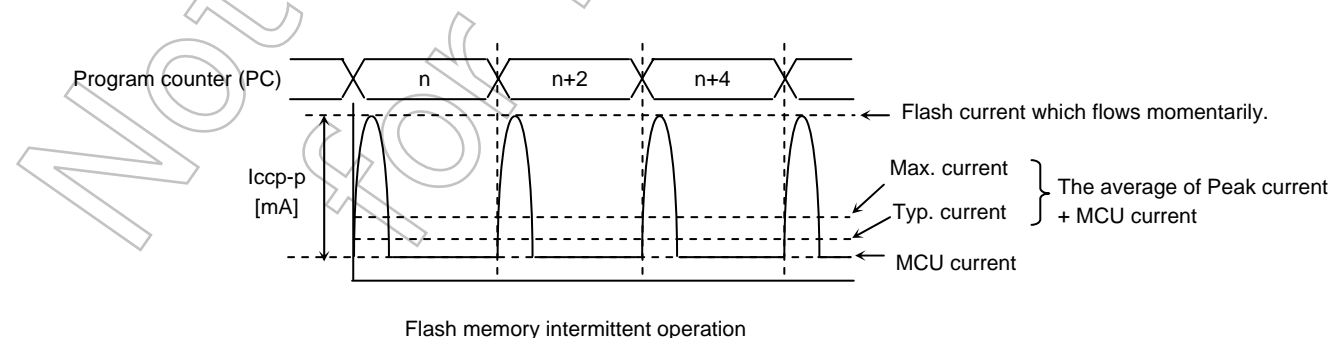

4.3 AC Characteristics

(1) $V_{CC} = 2.7V$ to $3.6V$

No.	Parameter	Symbol	Variable		$f_{FPH} = 27 \text{ MHz}$		Unit
			Min	Max	Min	Max	
1	f_{FPH} period (= x)	t_{FPH}	37.0	31250	37.0		ns
2	A0-A15 valid → ALE fall	t_{AL}	$0.5x - 6$		12		ns
3	ALE fall → A0-A15 hold	t_{LA}	$0.5x - 16$		2		ns
4	ALE High width	t_{LL}	$x - 20$		17		ns
5	ALE fall → \overline{RD} / \overline{WR} fall	t_{LC}	$0.5x - 14$		4		ns
6	\overline{RD} rise → ALE rise	t_{CLR}	$0.5x - 10$		8		ns
7	\overline{WR} rise → ALE rise	t_{CLW}	$x - 10$		27		ns
8	A0-A15 valid → \overline{RD} / \overline{WR} fall	t_{ACL}	$x - 23$		14		ns
9	A0-A23 valid → \overline{RD} / \overline{WR} fall	t_{ACH}	$1.5x - 26$		29		ns
10	\overline{RD} rise → A0-A23 hold	t_{CAR}	$0.5x - 13$		5		ns
11	\overline{WR} rise → A0-A23 hold	t_{CAW}	$x - 13$		24		ns
12	A0-15 valid → D0-D15 input	t_{ADL}		$3.0x - 38$		73	ns
13	A0-23 valid → D0-D15 input	t_{ADH}		$3.5x - 41$		88	ns
14	\overline{RD} fall → D0-D15 input	t_{RD}		$2.0x - 30$		44	ns
15	\overline{RD} Low width	t_{RR}	$2.0x - 15$		59		ns
16	\overline{RD} rise → D0-D15 hold	t_{HR}	0		0		ns
17	\overline{RD} rise → A0-A15 output	t_{RAE}	$x - 15$		22		ns
18	\overline{WR} Low width	t_{WW}	$1.5x - 15$		40		ns
19	D0-D15 valid → \overline{WR} rise	t_{DW}	$1.5x - 35$		20		ns
20	\overline{WR} rise → D0-D15 hold	t_{WD}	$x - 25$		12		ns
21	A0-A23 valid → \overline{WAIT} input <small>(1+n) WAIT mode</small>	t_{AWH}		$3.5x - 60$		69	ns
22	A0-A15 valid → \overline{WAIT} input <small>(1+n) WAIT mode</small>	t_{AWL}		$3.0x - 50$		61	ns
23	\overline{RD} / \overline{WR} fall → \overline{WAIT} hold <small>(1+n) WAIT mode</small>	t_{CW}	$2.0x + 0$		74		ns
24	A0-A23 valid → PORT input	t_{APH}		$3.5x - 89$		40	ns
25	A0-A23 valid → PORT hold	t_{APH2}	$3.5x$		129		ns
26	A0-A23 valid → PORT valid	t_{AP}		$3.5x + 80$		209	ns

AC measuring conditions

- Output level: High = $0.7 \times V_{CC}$, Low = $0.3 \times V_{CC}$, $CL = 50 \text{ pF}$
- Input level: High = $0.9 \times V_{CC}$, Low = $0.1 \times V_{CC}$

Note: Symbol x in the above table means the period of clock f_{FPH} , it's half period of the system clock f_{SYS} for CPU core. The period of f_{FPH} depends on the clock gear setting or the selection of high/low oscillator frequency.

(3) Write cycle

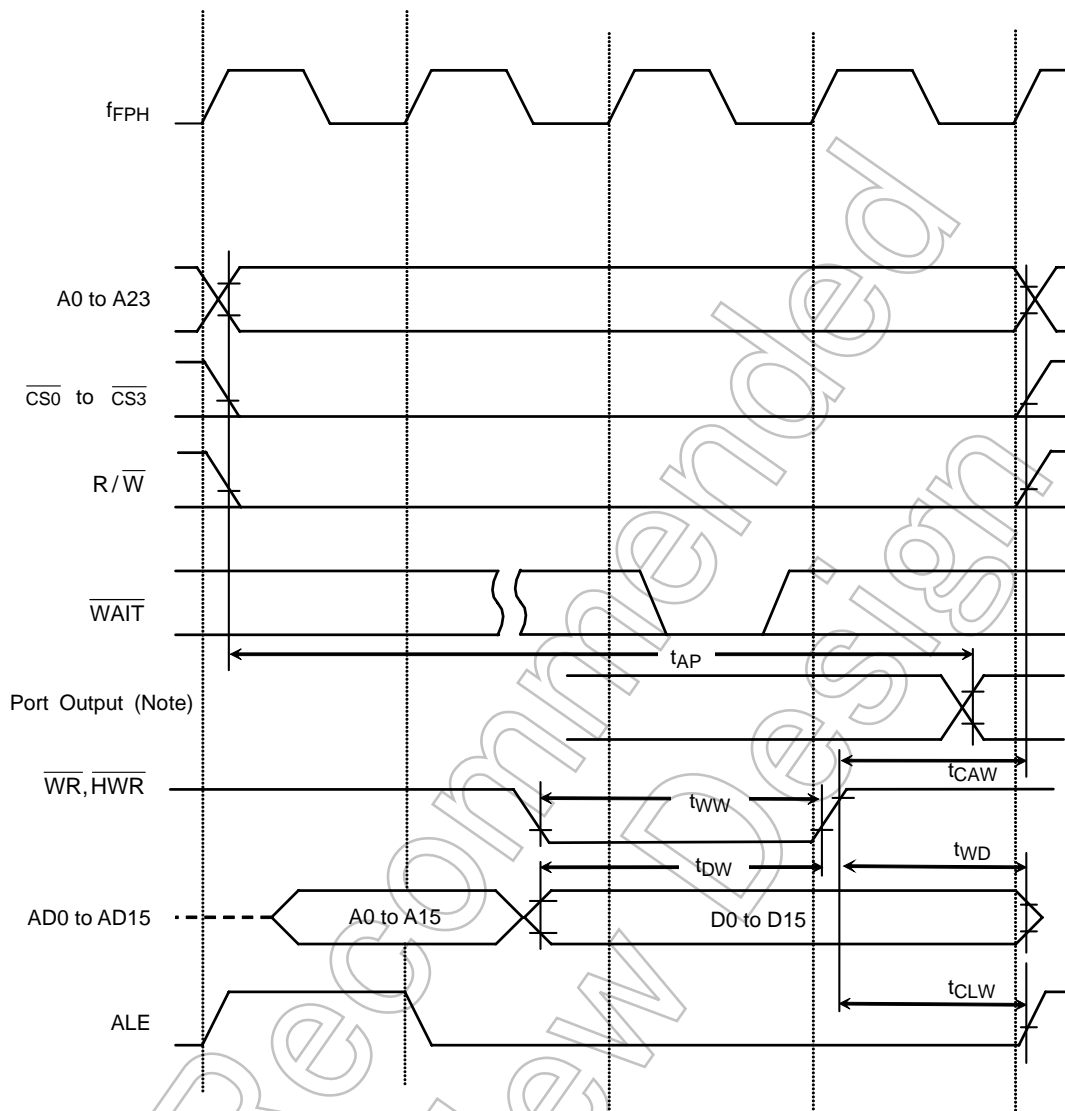

Note: Since the CPU accesses the internal area to write data to a port, the control signals of external pins such as \overline{WR} and \overline{CS} are not enabled. Therefore, the above waveform diagram should be regarded as depicting internal operation. Please also note that the timing and AC characteristics of port input/output shown above are typical representation. For details, contact your local Toshiba sales representative.

4.4 AD Conversion Characteristics

AVCC = VCC, AVSS = VSS

Parameter	Symbol	Condition	Min	Typ.	Max	Unit
Analog reference voltage (+)	VREFH	V _{CC} = 2.7V~3.6 V	V _{CC} - 0.2 V	V _{CC}	V _{CC}	V
Analog reference voltage (-)	VREFL	V _{CC} = 2.7V~3.6 V	V _{SS}	V _{SS}	V _{SS} + 0.2 V	
Analog input voltage range	VAIN		VREFL		VREFH	
Analog current for analog reference voltage <VREFON> = 1	IREF (VREFL = 0V)	V _{CC} = 2.7V~3.6 V		0.94	1.35	mA
<VREFON> = 0		V _{CC} = 2.7V~3.6 V		0.02	5.0	μA
Error (Not including quantizing errors)	—	V _{CC} = 2.7V~3.6 V		±1.0	±4.0	LSB

Note 1: 1 LSB = (VREFH - VREFL)/1024 [V]

Note 2: The operation above is guaranteed for $f_{EPH} \geq 4$ MHz.

Note 3: The value for I_{CC} includes the current which flows through the AVCC pin.

Not Recommended for New Designs

4.5 Serial Channel Timing (I/O Internal Mode)

(1) SCLK input mode

Parameter	Symbol	Variable		10 MHz		27 MHz		Unit
		Min	Max	Min	Max	Min	Max	
SCLK period	t _{SCY}	16X		1.6		0.59		μs
Output Data → SCLK rising /falling edge*	t _{OSS}	t _{SCY} /2 - 4X - 110		290		38		ns
SCLK rising /falling edge* → Output Data hold	t _{OHS}	t _{SCY} /2 + 2X + 0		1000		370		ns
SCLK rising /falling edge* → Input Data hold	t _{HSR}	3X + 10		310		121		ns
SCLK rising /falling edge* → Valid Data hold	t _{SRD}		t _{SCY} - 0	1600		592		ns
Valid data input → SCLK rising /falling edge*	t _{RDS}	0		0		0		ns

Note1: SCLK rising/falling edge: The rising edge is used in SCLK rising mode.
The falling edge is used in SCLK falling mode.

Note2: Above value is value at t_{SCY} = 16X.

(2) SCLK output mode

Parameter	Symbol	Variable		10 MHz		27 MHz		Unit
		Min	Max	Min	Max	Min	Max	
SCLK period	t _{SCY}	16X	8192X	1.6	819	0.59	303	μs
Output Data → SCLK rising /falling edge*	t _{OSS}	t _{SCY} /2 - 40		760		256		ns
SCLK rising /falling edge* → Output Data hold	t _{OHS}	t _{SCY} /2 - 40		760		256		ns
SCLK rising /falling edge* → Input Data hold	t _{HSR}	0		0		0		ns
SCLK rising /falling edge* → Valid Data hold	t _{SRD}		t _{SCY} - 1X - 180	1320		375		ns
Valid data input → SCLK rising /falling edge*	t _{RDS}	1X + 180		280		217		ns

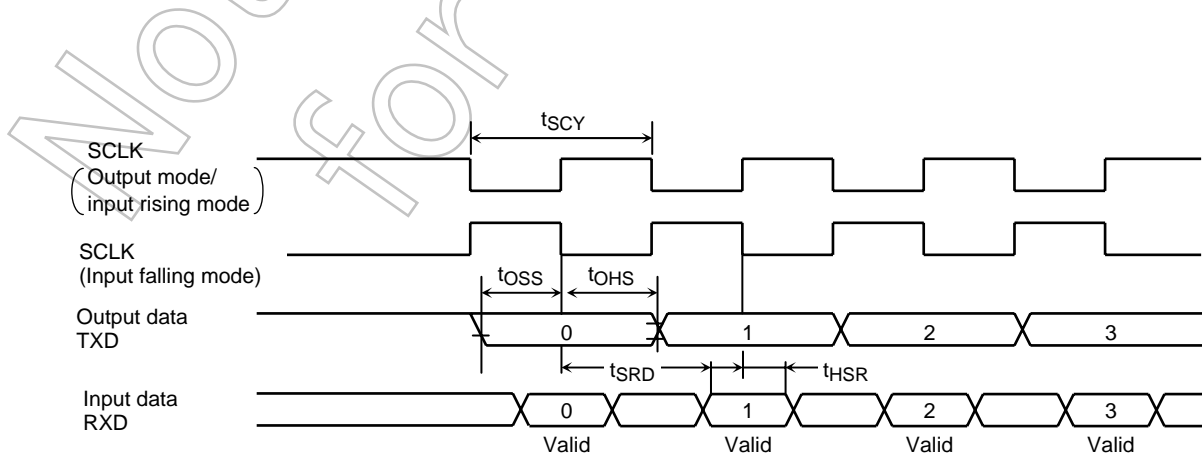

4.6 Event Counter (TA0IN, TA4IN, TB0IN0, TB0IN1, TB1IN0, TB1IN1)

Parameter	Symbol	Variable		10 MHz		27 MHz		Unit
		Min	Max	Min	Max	Min	Max	
Clock period	t_{VCK}	$8X + 100$		900		396		ns
Clock low level width	t_{VCKL}	$4X + 40$		440		188		ns
Clock high level width	t_{VCKH}	$4X + 40$		440		188		ns

4.7 Interrupt, Capture

(1) \overline{NMI} , INT0 to INT4 interrupts

Parameter	Symbol	Variable		10 MHz		27 MHz		Unit
		Min	Max	Min	Max	Min	Max	
\overline{NMI} , INT0 to INT4 low level width	t_{INTAL}	$4X + 40$		440		188		ns
\overline{NMI} , INT0 to INT4 high level width	t_{INTAH}	$4X + 40$		440		188		ns

(2) INT5 to INT8 interrupts and Capture

The INT5 to INT8 input width depends on the system clock and prescaler clock settings.

Select System Clock SYSCR1 <SYSCK>	Select Prescaler Clock SYSCR0 <PRCK1:0>	t_{INTBL} (INT5~INT8 Low level width)		t_{INTBH} (INT5~INT8 High level width)		Unit
		Variable	$f_{FPH} = 27 \text{ MHz}$	Variable	$f_{FPH} = 27 \text{ MHz}$	
		Min	Min	Min	Min	
0 (f_c)	00 (f_{FPH})	$8X + 100$	396	$8X + 100$	396	ns
	10 ($f_c/16$)	$128Xc + 0.1$	4.8	$128Xc + 0.1$	4.8	μs
1 (f_s)	00 (f_{FPH})	$8X + 0.1$	244.3	$8X + 0.1$	244.3	

Note: Xc = Period of Clock f_c

4.8 SCOUT Pin AC Characteristics

Parameter	Symbol	Variable		10 MHz		27MHz		Condition	Unit
		Min	Max	Min	Max	Min	Max		
High level width	t_{SCH}	$0.5T - 13$		37		5		$V_{CC} = 2.7V \text{ to } 3.6V$	ns
Low level width	t_{SCL}	$0.5T - 13$		37		5		$V_{CC} = 2.7V \text{ to } 3.6V$	ns

Note: T = Period of SCOUT

Measuring conditions

- Output level: High = $0.7 V_{CC}$, Low = $0.3 V_{CC}$, $CL = 10 \text{ pF}$

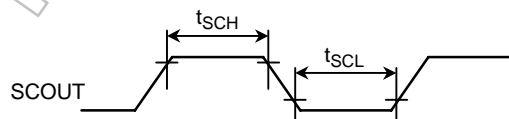

4.9 Bus Request/Bus Acknowledge

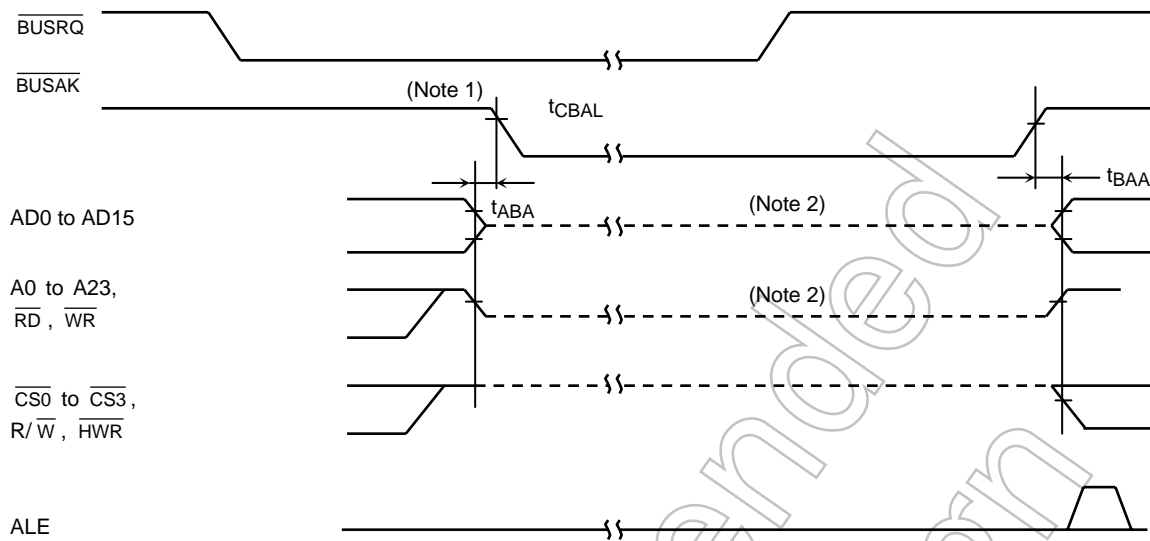

Parameter	Symbol	Variable		f _{FPH} = 10 MHz		f _{FPH} = 27 MHz		Condition	Unit
		Min	Max	Min	Max	Min	Max		
Output buffer off to $\overline{\text{BUSAK}}$ low	t _{ABA}	0	80	0	80	0	80	V _{CC} = 2.7V to 3.6V	ns
$\overline{\text{BUSAK}}$ high to output buffer on	t _{BAA}	0	80	0	80	0	80	V _{CC} = 2.7V to 3.6V	ns

Note 1: Even if the $\overline{\text{BUSRQ}}$ signal goes low, the bus will not be released while the $\overline{\text{WAIT}}$ signal is low. The bus will only be released when $\overline{\text{BUSRQ}}$ goes low while $\overline{\text{WAIT}}$ is high.

Note 2: This line shows only that the output buffer is in the off state.

It does not indicate that the signal level is fixed.

Just after the bus is released, the signal level set before the bus was released is maintained dynamically by the external capacitance. Therefore, to fix the signal level using an external resistor during bus release, careful design is necessary, since fixing of the level is delayed. The internal programmable pull-up/pull-down resistor is switched between the active and non-active states by the internal signal.

4.10 Flash Characteristics

(1) Rewriting

Parameter	Condition	Min	Typ	Max	Unit
Guarantee on Flash-memory rewriting	V _{CC} = 3.0V to 3.6V, f _c = 4 to 27 MHz T _a = -10~40°C	—	—	100	Times

4.11 Recommended Crystal Oscillation Circuit

TMP91FY42FG is evaluated by below oscillator vender. When selecting external parts, make use of this information.

Note: Total loads value of oscillator is sum of external loads (C1 and C2) and floating loads of actual assemble board. There is a possibility of miss-operating using C1 and C2 value in below table. When designing board, it should design minimum length pattern around oscillator. And we recommend that oscillator evaluation try on your actual using board.

(1) Connection example

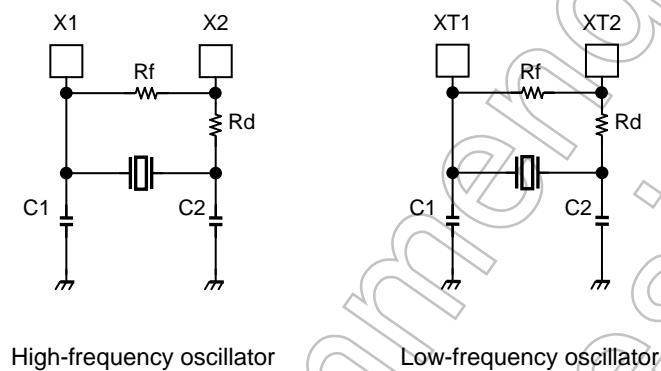

(2) TMP91FY42 recommended ceramic oscillator: Murata Manufacturing Co., Ltd. (JAPAN)

MCU	Oscillation Frequency [MHz]	Item of Oscillator		Parameter of elements				Running Condition	
				C1 [pF]	C2 [pF]	Rf [Ω]	Rd [Ω]	Voltage of Power [V]	Ta [$^{\circ}$ C]
TMP91FY42FG	4.00	SMD	CSTCR4M00G55-R0	(39)	(39)	Open	1.5k	2.2 to 3.6	-40~85°C
		Read	CSTLS4M00G56-B0	(47)	(47)				
	8.00	SMD	CSTCE8M00G55-R0	(33)	(33)		470		
		Read	CSTLS8M00G56-B0	(47)	(47)				
	10.00	SMD	CSTCE10M00G55-R0	(33)	(33)		330		
		Read	CSTLS10M00G56-B0	(47)	(47)				
	16.0	SMD	CSTCE16M0V53-R0	(15)	(15)		68		
		Read	CSALS16M0X55-B0	7	7			150	
	20.0	SMD	CSTCE20M0V53-R0	(15)	(15)		0		
		Read	CSTLS20M0X51-B0	(5)	(5)				
27.0	Small SMD	CSTCG27M0V51-R0	(5)	(5)	0				

- The values enclosed in brackets in the C1 and C2 columns apply to the condenser built-in type.
- The product numbers and specifications of the resonators by Murata Manufacturing Co., Ltd. are subject to change. For up-to-date information, please refer to the following URL;

<http://www.murata.co.jp>

5. Table of SFRs

The special function registers (SFRs) include the I/O ports and peripheral control registers allocated to the 4-Kbyte address space from 000000H to 000FFFH.

- (1) I/O ports
- (2) I/O port control
- (3) Interrupt control
- (4) Chip select/wait control
- (5) Clock gear
- (6) DFM (Clock doubler)
- (7) 8-bit timer
- (8) 16-bit timer
- (9) UART/serial channel
- (10) I²C bus/serial interface
- (11) AD converter
- (12) Watchdog timer
- (13) Special timer for CLOCK

Table layout

Symbol	Name	Address	7	6	5	4	3	2	1	0	
											→ Bit symbol
											→ Read/Write
											→ Initial value after reset
											→ Remarks

Note: "Prohibit RMW" in the table means that you cannot use RMW instructions on these register.

Example: When setting bit0 only of the register PxCR, the instruction "SET 0, (PxCR)" cannot be used. The LD (Transfer) instruction must be used to write all eight bits.

Read/write

R/W: Both read and write are possible.

R: Only read is possible.

W: Only write is possible.

W*: Both read and write are possible (when this bit is read as 1).

Prohibit RMW: Read-modify-write instructions are prohibited. (The EX, ADD, ADC, BUS, SBC, INC, DEC, AND, OR, XOR, STCF, RES, SET, CHG, TSET, RLC, RRC, RL, RR, SLA, SRA, SLL, SRL, RLD and RRD instruction are read-modify-write instructions.)

R/W*: Read-modify-write is prohibited when controlling the pull-up resistor.

Table 5.1 SFR Address Map

[1] PORT

Address	Name
0000H	P0
1H	P1
2H	P0CR
3H	
4H	P1CR
5H	P1FC
6H	P2
7H	P3
8H	P2CR
9H	P2FC
AH	P3CR
BH	P3FC
CH	P4
DH	P5
EH	P4CR
FH	P4FC

Address	Name
0010H	
1H	
2H	P6
3H	P7
4H	P6CR
5H	P6FC
6H	P7CR
7H	P7FC
8H	P8
9H	P9
AH	P8CR
BH	P8FC
CH	P9CR
DH	P9FC
EH	PA
FH	

Address	Name
0020H	PACR
1H	PAFC
2H	
3H	
4H	
5H	
6H	
7H	
8H	
9H	
AH	
BH	
CH	
DH	
EH	
FH	ODE

[2] INTC

Address	Name
0080H	DMA0V
1H	DMA1V
2H	DMA2V
3H	DMA3V
4H	
5H	
6H	
7H	
8H	INTCLR
9H	DMAR
AH	DMAB
BH	
CH	IIMC
DH	
EH	
FH	

Address	Name
0090H	INTE0AD
1H	INTE12
2H	INTE34
3H	INTE56
4H	INTE78
5H	INTETA01
6H	INTETA23
7H	INTETA45
8H	INTETA67
9H	INTETB0
AH	INTETB1
BH	INTETB01V
CH	INTES0
DH	INTES1
EH	INTSBIRTC
FH	

Address	Name
00A0H	INTETC01
1H	INTETC23
2H	
3H	
4H	
5H	
6H	
7H	
8H	
9H	
AH	
BH	
CH	
DH	
EH	
FH	

[3] CS/WAIT

Address	Name
00C0H	B0CS
1H	B1CS
2H	B2CS
3H	B3CS
4H	
5H	
6H	
7H	BEXCS
8H	MSAR0
9H	MAMR0
AH	MSAR1
BH	MAMR1
CH	MSAR2
DH	MAMR2
EH	MSAR3
FH	MAMR3

Note: Do not access to the unnamed addresses (e.g., addresses to which no register has been allocated).

Table 5.2 SFR Address Map

[4] CGEAR, DFM

Address	Name
00E0H	SYSCR0
1H	SYSCR1
2H	SYSCR2
3H	EMCCR0
4H	EMCCR1
5H	
6H	
7H	
8H	DFMCR0
9H	
AH	
BH	
CH	
DH	
EH	
FH	

Address	Name
00F0H	
1H	
2H	
3H	
4H	
5H	
6H	
7H	
8H	
9H	
AH	
BH	
CH	
DH	
EH	
FH	

[5] TMRA

Address	Name
0100H	TA01RUN
1H	
2H	TA0REG
3H	TA1REG
4H	TA01MOD
5H	TA1FFCR
6H	
7H	
8H	TA23RUN
9H	
AH	TA2REG
BH	TA3REG
CH	TA23MOD
DH	TA3FFCR
EH	
FH	

Address	Name
0110H	TA45RUN
1H	
2H	TA4REG
3H	TA5REG
4H	TA45MOD
5H	TA5FFCR
6H	
7H	
8H	TA67RUN
9H	
AH	TA6REG
BH	TA7REG
CH	TA67MOD
DH	TA7FFCR
EH	
FH	

[6] TMRB

Address	Name
0180H	TB0RUN
1H	
2H	TB0MOD
3H	TB0FFCR
4H	
5H	
6H	
7H	
8H	TB0RG0L
9H	TB0RG0H
AH	TB0RG1L
BH	TB0RG1H
CH	TB0CP0L
DH	TB0CP0H
EH	TB0CP1L
FH	TB0CP1H

Address	Name
0190H	TB1RUN
1H	
2H	TB1MOD
3H	TB1FFCR
4H	
5H	
6H	
7H	
8H	TB1RG0L
9H	TB1RG0H
AH	TB1RG1L
BH	TB1RG1H
CH	TB1CP0L
DH	TB1CP0H
EH	TB1CP1L
FH	TB1CP1H

Note: Do not access to the unnamed addresses (e.g., addresses to which no register has been allocated).

Table 5.3 SFR Address Map

[7] UART/SIO

Address	Name
0200H	SC0BUF
1H	SC0CR
2H	SC0MOD0
3H	BR0CR
4H	BR0ADD
5H	SC0MOD1
6H	
7H	SIRCR
8H	SC1BUF
9H	SC1CR
AH	SC1MOD0
BH	BR1CR
CH	BR1ADD
DH	SC1MOD1
EH	
FH	

[8] I²C bus/SIO

Address	Name
0240H	SBI0CR1
1H	SBI0DBR
2H	I2C0AR
3H	SBI0CR2/SBI0SR
4H	SBI0BR0
5H	SBI0BR1
6H	
7H	
8H	
9H	
AH	
BH	
CH	
DH	
EH	
FH	

[9] 10 bit ADC

Address	Name
02A0H	ADREG04L
1H	ADREG04H
2H	ADREG15L
3H	ADREG15H
4H	ADREG26L
5H	ADREG26H
6H	ADREG37L
7H	ADREG37H
8H	
9H	
AH	
BH	
CH	
DH	
EH	
FH	

Address	Name
02B0H	ADM0D0
1H	ADM0D1
2H	
3H	
4H	
5H	
6H	
7H	
8H	
9H	
AH	
BH	
CH	
DH	
EH	
FH	

[10] WDT

Address	Name
0300H	WDMOD
1H	WDCR
2H	
3H	
4H	
5H	
6H	
7H	
8H	
9H	
AH	
BH	
CH	
DH	
EH	
FH	

[11] Special timer for CLOCK

Address	Name
0310H	RTCCR
1H	
2H	
3H	
4H	
5H	
6H	
7H	
8H	
9H	
AH	
BH	
CH	
DH	
EH	
FH	

Note: Do not access to the unnamed addresses (e.g., addresses to which no register has been allocated).

(1) I/O ports

Symbol	Name	Address	7	6	5	4	3	2	1	0			
P0	Port 0	00H	P07	P06	P05	P04	P03	P02	P01	P00			
			R/W										
			Data from external port (Output latch register is undefined.)										
P1	Port 1	01H	P17	P16	P15	P14	P13	P12	P11	P10			
			R/W										
			Data from external port (Output latch register is cleared to 0.)										
P2	Port 2	06H	P27	P26	P25	P24	P23	P22	P21	P20			
			R/W										
			Data from external port (Output latch register is cleared to 0.)										
P3	Port 3	07H (Prohibit RMW)	P37	P36	P35	P34	P33	P32	P31	P30			
			*R/W										
			Data from external port (Output latch register is set to 1.)										
			0 (Output latch register): Pull-up resistor OFF 1(Output latch register): Pull-up resistor ON										
P4	Port 4	0CH (Prohibit RMW)	/				P43	P42	P41	P40			
			*R/W										
			Data from external port (Output latch register is set to 1.)										
			0 (Output latch register): Pull-up resistor OFF 1(Output latch register): Pull-up resistor ON										
P5	Port 5	0DH	P57	P56	P55	P54	P53	P52	P51	P50			
			R										
			Data from external port										
P6	Port 6	12H	/				P66	P65	P64	P63	P62	P61	P60
			R/W										
			Data from external port (Output latch register is set to 1.)										
P7	Port 7	13H	/				P75	P74	P73	P72	P71	P70	
			R/W										
			Data from external port (Output latch register is set to 1.)										
P8	Port 8	18H	P87	P86	P85	P84	P83	P82	P81	P80			
			R/W										
			Data from external port (Output latch register is set to 1.)										
P9	Port 9	19H	P97	P96	P95	P94	P93	P92	P91	P90			
			R/W										
			Data from external port (Output latch register is set to 1.)										
PA	Port A	1EH	PA7	PA6	PA5	PA4	PA3	PA2	PA1	PA0			
			R/W										
			Data from external port (Output latch register is set to 1.)										

(2) I/O port control (1/2)

Symbol	Name	Address	7	6	5	4	3	2	1	0
P0CR	Port 0 control	02H (Prohibit RMW)	P07C	P06C	P05C	P04C	P03C	P02C	P01C	P00C
			W							
			0	0	0	0	0	0	0	0
			0: Input 1: Output							
P1CR	Port 1 control	04H (Prohibit RMW)	P17C	P16C	P15C	P14C	P13C	P12C	P11C	P10C
			W							
			0	0	0	0	0	0	0	0
			0: Input 1: Output							
P1FC	Port 1 function	05H (Prohibit RMW)	P17F	P16F	P15F	P14F	P13F	P12F	P11F	P10F
			W							
			0	0	0	0	0	0	0	0
			P1FC/P1CR = 00: Input port 01: Output port 10: AD8~AD15 11: A8~A15							
P2CR	Port 2 control	08H (Prohibit RMW)	P27C	P26C	P25C	P24C	P23C	P22C	P21C	P20C
			W							
			0	0	0	0	0	0	0	0
			0: Input 1: Output							
P2FC	Port 2 function	09H (Prohibit RMW)	P27F	P26F	P25F	P24F	P23F	P22F	P21F	P20F
			W							
			0	0	0	0	0	0	0	0
			P2FC/P2CR = 00: Input port 01: Output port 10: A0~A7 11: A16~A23							
P3CR	Port 3 control	0AH Prohibit RMW)	P37C	P36C	P35C	P34C	P33C	P32C		
			W							
			0	0	0	0	0	0		
			0: Input 1: Output							
P3FC	Port 3 function	0BH (Prohibit RMW)	-	P36F	P35F	P34F		P32F	P31F	P30F
			W							
			0	0	0	0		0	0	0
			Always write "0"	0: Port 1: R/W	0: Port 1: $\overline{\text{BUSAK}}$	0: Port 1: $\overline{\text{BUSRQ}}$		0: Port 1: $\overline{\text{HWR}}$	0: Port 1: $\overline{\text{WR}}$	0: Port 1: $\overline{\text{RD}}$
P4CR	Port 4 control	0EH (Prohibit RMW)					P43C	P42C	P41C	P40C
			W							
							0	0	0	0
			0: Input 1: Output							
P4FC	Port 4 function	0FH (Prohibit RMW)					P43F	P42F	P41F	P40F
			W							
							0	0	0	0
							0: Port 1: $\overline{\text{CS3}}$	0: Port 1: $\overline{\text{CS2}}$	0: Port 1: $\overline{\text{CS1}}$	0: Port 1: $\overline{\text{CS0}}$
P6CR	Port 6 control	14H (Prohibit RMW)		P66C	P65C	P64C	P63C	P62C	P61C	P60C
			W							
				0	0	0	0	0	0	0
			0: Input 1: Output							
P6FC	Port 6 function	15H (Prohibit RMW)				P64F	P63F	P62F	P61F	P60F
			W							
						0	0	0	0	0
						0: Port 1: SCOUT	0: Port 1: INT0	0: Port 1: SCL	0: Port 1: SDA/SO	0: Port 1: SCK output

Note: When Internal area is read, P30 output "L" level from P30 pin by P3<P30> = "0" and P3FC<P30F> = "1". Only when an external address is accessed, P30 outputs $\overline{\text{RD}}$ when output latch register P30 is set to "1".

I/O port control (2/2)

Symbol	Name	Address	7	6	5	4	3	2	1	0		
P7CR	Port 7 control	16H (Prohibit RMW)	7	6	P75C	P74C	P73C	P72C	P71C	P70C		
			W									
			0	0	0	0	0	0	0	0		
			0: Input				1: Output					
P7FC	Port 7 function	17H (Prohibit RMW)	7	6	P75F	P74F	3	P72F	P71F	0		
			W					W				
			0	0	0	0	0	0	0			
			0: Port 1: TA7OUT		0: Port 1: TA5OUT		0: Port 1: TA3OUT		0: Port 1: TA1OUT			
P8CR	Port 8 control	1AH (Prohibit RMW)	P87C	P86C	P85C	P84C	P83C	P82C	P81C	P80C		
			W									
			0	0	0	0	0	0	0	0		
			0: Input				1: Output					
P8FC	Port 8 function	1BH (Prohibit RMW)	P87F	P86F	P85F	P84F	P83F	P82F	P81F	P80F		
			W									
			0	0	0	0	0	0	0	0		
			0: Port 1: TB1OUT	0: Port 1: TB1OUT	0: Port 1: INT8/ TB1IN1	0: Port 1: INT7/ TB1IN0	0: Port 1: TB0OUT1	0: Port 1: TB0OUT0	0: Port 1: INT6/ TB0IN1	0: Port 1: INT5/ TB0IN0		
P9CR	Port 9 control	1CH (Prohibit RMW)	P97C	P96C	P95C	P94C	P93C	P92C	P91C	P90C		
			W									
			1	1	0	0	0	0	0	0		
			0: Input				1: Output					
P9FC	Port 9 function	1DH (Prohibit RMW)	7	6	P95F	4	P93F	P92F	1	P90F		
			W				W			W		
			0	0	0	0	0	0	0			
			0: Port 1: SCLK1		0: Port 1: TXD1		0: Port 1: SCLK0		0: Port 1: TXD0			
PACR	Port A control	20H (Prohibit RMW)	PA7C	PA6C	PA5C	PA4C	PA3C	PA2C	PA1C	PA0C		
			W									
			0	0	0	0	0	0	0	0		
			0: Input				1: Output					
PAFC	Port A function	21H (Prohibit RMW)	-	-	-	-	PA3F	PA2F	PA1F	PA0F		
			W									
			0	0	0	0	0	0	0	0		
			Always write "0"				INT4~INT1input enable					
ODE	Serial open-drain enable	2FH	7	6	5	4	ODE62	ODE61	ODE93	ODE90		
			R/W									
			0	0	0	0	0	0	0	0		
			1: P62ODE		1: P61ODE		1: P93ODE		1: P90ODE			

Note 1: External interrupt INT0

Input-setting use P6FC<P63F>. Level/edge-setting and rising/falling-setting use IIMC<I0LE, I0EDGE>.

Note 2: External interrupt INT1~INT4

Input-setting use PAFC<PA3F:PA0F>. Rising/falling-setting use IIMC<I4EDGE:I1EDGE>.

Note 3: External interrupt INT5~INT8

Input-setting use P8FC<P85F, P84F, P81F, P80F>. Edge-setting use TB0MOD and TB1MOD registers.

(3) Interrupt control (1/3)

Symbol	Name	Address	7	6	5	4	3	2	1	0
INTE0AD	INT0 & INTAD enable	90H	INTAD				INT0			
			IADC	IADM2	IADM1	IADM0	I0C	I0M2	I0M1	I0M0
			R	R/W			R	R/W		
			0	0	0	0	0	0	0	0
			1: INTAD	Interrupt level			1: INT0	Interrupt level		
INTE12	INT1 & INT2 enable	91H	INT2				INT1			
			I2C	I2M2	I2M1	I2M0	I1C	I1M2	I1M1	I1M0
			R	R/W			R	R/W		
			0	0	0	0	0	0	0	0
			1: INT2	Interrupt level			1: INT1	Interrupt level		
INTE34	INT3 & INT4 enable	92H	INT4				INT3			
			I4C	I4M2	I4M1	I4M0	I3C	I3M2	I3M1	I3M0
			R	R/W			R	R/W		
			0	0	0	0	0	0	0	0
			1: INT4	Interrupt level			1: INT3	Interrupt level		
INTE56	INT5 & INT6 enable	93H	INT6				INT5			
			I6C	I6M2	I6M1	I6M0	I5C	I5M2	I5M1	I5M0
			R	R/W			R	R/W		
			0	0	0	0	0	0	0	0
			1: INT6	Interrupt level			1: INT5	Interrupt level		
INTE78	INT7 & INT8 enable	94H	INT8				INT7			
			I8C	I8M2	I8M1	I8M0	I7C	I7M2	I7M1	I7M0
			R	R/W			R	R/W		
			0	0	0	0	0	0	0	0
			1: INT8	Interrupt level			1: INT7	Interrupt level		
INTEA01	INTTA0 & INTTA1 enable	95H	INTTA1 (TMRA1)				INTTA0 (TMRA0)			
			ITA1C	ITA1M2	ITA1M1	ITA1M0	ITA0C	ITA0M2	ITA0M1	ITA0M0
			R	R/W			R	R/W		
			0	0	0	0	0	0	0	0
			1: INTTA1	Interrupt level			1: INTTA0	Interrupt level		
INTEA23	INTTA2 & INTTA3 enable	96H	INTTA3 (TMRA3)				INTTA2 (TMRA2)			
			ITA3C	ITA3M2	ITA3M1	ITA3M0	ITA2C	ITA2M2	ITA2M1	ITA2M0
			R	R/W			R	R/W		
			0	0	0	0	0	0	0	0
			1: INTTA3	Interrupt level			1: INTTA2	Interrupt level		
INTEA45	INTTA4 & INTTA5 enable	97H	INTTA5 (TMRA5)				INTTA4 (TMRA4)			
			ITA5C	ITA5M2	ITA5M1	ITA5M0	ITA4C	ITA4M2	ITA4M1	ITA4M0
			R	R/W			R	R/W		
			0	0	0	0	0	0	0	0
			1: INTTA5	Interrupt level			1: INTTA4	Interrupt level		
INTEA67	INTTA6 & INTTA7 enable	98H	INTTA7 (TMRA7)				INTTA6 (TMRA6)			
			ITA7C	ITA7M2	ITA7M1	ITA7M0	ITA6C	ITA6M2	ITA6M1	ITA6M0
			R	R/W			R	R/W		
			0	0	0	0	0	0	0	0
			1: INTTA7	Interrupt level			1: INTTA6	Interrupt level		

Interrupt control (2/3)

Symbol	Name	Address	7	6	5	4	3	2	1	0
INTETB0	INTTB00 & INTTB01 enable	99H	INTTB01 (TMRB0)				INTTB00 (TMRB0)			
			ITB01C	ITB01M2	ITB01M1	ITB01M0	ITB00C	ITB00M2	ITB00M1	ITB00M0
			R	R/W			R	R/W		
			0	0	0	0	0	0	0	0
			1:INTTB01	Interrupt level			1:INTTB00	Interrupt level		
INTETB1	INTTB10 & INTTB11 enable	9AH	INTTB11 (TMRB1)				INTTB10 (TMRB1)			
			ITB11C	ITB11M2	ITB11M1	ITB11M0	ITB10C	ITB10M2	ITB10M1	ITB10M0
			R	R/W			R	R/W		
			0	0	0	0	0	0	0	0
			1:INTTB11	Interrupt level			1:INTTB10	Interrupt level		
INTETB01V	INTTBOF0 & INTTBOF1 enable (Over-flow)	9BH	INTTBOF1 (TMRB1 over flow)				INTTBOF0 (TMRB0 over flow)			
			ITF1C	ITF1M2	ITF1M1	ITF1M0	ITF0C	ITF0M2	ITF0M1	ITF0M0
			R	R/W			R	R/W		
			0	0	0	0	0	0	0	0
			1:INTTBOF1	Interrupt level			1:INTTBOF0	Interrupt level		
INTES0	INTRX0 & INTTX0 enable	9CH	INTTX0				INTRX0			
			ITX0C	ITX0M2	ITX0M1	ITX0M0	IRX0C	IRX0M2	IRX0M1	IRX0M0
			R	R/W			R	R/W		
			0	0	0	0	0	0	0	0
			1:INTTX0	Interrupt level			1:INTRX0	Interrupt level		
INTES1	INTRX1 & INTTX1 enable	9DH	INTTX1				INTRX1			
			ITX1C	ITX1M2	ITX1M1	ITX1M0	IRX1C	IRX1M2	IRX1M1	IRX1M0
			R	R/W			R	R/W		
			0	0	0	0	0	0	0	0
			1:INTTX1	Interrupt level			1:INTRX1	Interrupt level		
INTES2RTC	INTSBI & INTRTC enable	9EH	INTRTC				INTSBI			
			IRTC	IRTCM2	IRTCM1	IRTCM0	ISBIC	ISBIM2	ISBIM1	ISBIM0
			R	R/W			R	R/W		
			0	0	0	0	0	0	0	0
			1:INTRTC	Interrupt level			1:INTSBI	Interrupt level		
INTETC01	INTTC0 & INTTC1 enable	A0H	INTTC1				INTTC0			
			ITC1C	ITC1M2	ITC1M1	ITC1M0	ITC0C	ITC0M2	ITC0M1	ITC0M0
			R	R/W			R	R/W		
			0	0	0	0	0	0	0	0
INTETC23	INTTC2 & INTTC3 enable	A1H	INTTC3				INTTC2			
			ITC3C	ITC3M2	ITC3M1	ITC3M0	ITC2C	ITC2M2	ITC2M1	ITC2M0
			R	R/W			R	R/W		
			0	0	0	0	0	0	0	0

Interrupt control (3/3)

Symbol	Name	Address	7	6	5	4	3	2	1	0
DMA0V	DMA 0 start vector	80H			DMA0V5	DMA0V4	DMA0V3	DMA0V2	DMA0V1	DMA0V0
					R/W					
					0	0	0	0	0	0
					DMA0 start vector					
DMA1V	DMA 1 start vector	81H			DMA1V5	DMA1V4	DMA1V3	DMA1V2	DMA1V1	DMA1V0
					R/W					
					0	0	0	0	0	0
					DMA1 start vector					
DMA2V	DMA 2 start vector	82H			DMA2V5	DMA2V4	DMA2V3	DMA2V2	DMA2V1	DMA2V0
					R/W					
					0	0	0	0	0	0
					DMA2 start vector					
DMA3V	DMA 3 start vector	83H			DMA3V5	DMA3V4	DMA3V3	DMA3V2	DMA3V1	DMA3V0
					R/W					
					0	0	0	0	0	0
					DMA3 start vector					
INTCLR	Interrupt clear control	88H (Prohibit RMW)			CLR5	CLR4	CLR3	CLR2	CLR1	CLR0
					W					
					0	0	0	0	0	0
					Clears interrupt request flag by writing to DMA start vector					
DMAR	DMA software request register	89H (Prohibit RMW)					DMAR3	DMAR2	DMAR1	DMAR0
							R/W			
					0	0	0	0		
					1: DMA request in software					
DMAB	DMA burst request register	8AH					DMAB3	DMAB2	DMAB1	DMAB0
							R/W			
					0	0	0	0		
					1: DMA request on burst mode					
IIMC	Interrupt input mode control	8CH (Prohibit RMW)	I4EDGE		I3EDGE	I2EDGE	I1EDGE	I0EDGE	I0LE	NMIREE
			W							
			0	0	0	0	0	0	0	0
			Always write "0".	INT4 edge 0: Rising 1: Falling	INT3 edge 0: Rising 1: Falling	INT2 edge 0: Rising 1: Falling	INT1 edge 0: Rising 1: Falling	INT0 edge 0: Rising 1: Falling	INT0 0: edge 1: level	1: Operation Even on NMI rising edge

(4) Chip select/wait control (1/2)

Symbol	Name	Address	7	6	5	4	3	2	1	0		
B0CS	Block 0 CS/WAIT control register	C0H (Prohibit RMW)	B0E		B0OM1	B0OM0	B0BUS	B0W2	B0W1	B0W0		
			W		W							
			0		0	0	0	0	0	0		
			0: Disable 1: Enable		00: ROM/SRAM 01: } 10: } Reserved 11: }	Data bus width 0: 16 bits 1: 8 bits	000: 2 waits 001: 1 wait 010: (1 + N) wait 011: 0 waits	100: Reserved 101: 3 waits 110: 4 waits 111: 8 waits				
B1CS	Block 1 CS/WAIT control register	C1H (Prohibit RMW)	B1E		B1OM1	B1OM0	B1BUS	B1W2	B1W1	B1W0		
			W		W							
			0		0	0	0	0	0	0		
			0: Disable 1: Enable		00: ROM/SRAM 01: } 10: } Reserved 11: }	Data bus width 0: 16 bits 1: 8 bits	000: 2 waits 001: 1 wait 010: (1 + N) wait 011: 0 waits	100: Reserved 101: 3 waits 110: 4 waits 111: 8 waits				
B2CS	Block 2 CS/WAIT control register	C2H (Prohibit RMW)	B2E	B2M	B2OM1	B2OM0	B2BUS	B2W2	B2W1	B2W0		
			W									
			1	0	0	0	0	0	0	0		
			0: Disable 1: Enable	0: 16 M Area 1: Area set	00: ROM/SRAM 01: } 10: } Reserved 11: }	Data bus width 0: 16 bits 1: 8 bits	000: 2 waits 001: 1 wait 010: (1 + N) wait 011: 0 waits	100: Reserved 101: 3 waits 110: 4 waits 111: 8 waits				
B3CS	Block 3 CS/WAIT control register	C3H (Prohibit RMW)	B3E		B3OM1	B3OM0	B3BUS	B3W2	B3W1	B3W0		
			W		W							
			0		0	0	0	0	0	0		
			0: Disable 1: Enable		00: ROM/SRAM 01: } 10: } Reserved 11: }	Data bus width 0: 16 bits 1: 8 bits	000: 2 waits 001: 1 wait 010: (1 + N) wait 011: 0 waits	100: Reserved 101: 3 waits 110: 4 waits 111: 8 waits				
BEXCS	External CS/WAIT control register	C7H (Prohibit RMW)					BEXBUS	BEXW2	BEXW1	BEXW0		
			W									
							0	0	0	0		
							Data bus width 0: 16 bits 1: 8 bits	000: 2 waits 001: 1 wait 010: (1 + N) wait 011: 0 waits	100: Reserved 101: 3 waits 110: 4 waits 111: 8 waits			
MSAR0	Memory start address register 0	C8H	S23	S22	S21	S20	S19	S18	S17	S16		
			R/W									
			1	1	1	1	1	1	1	1		
Start address A23 to A16												
MAMR0	Memory address mask register 0	C9H	V20	V19	V18	V17	V16	V15	V14-V9	V8		
			R/W									
			1	1	1	1	1	1	1	1		
CS0 area size 0: Enable to address comparison												
MSAR1	Memory start address register 1	CAH	S23	S22	S21	S20	S19	S18	S17	S16		
			R/W									
			1	1	1	1	1	1	1	1		
Start address A23 to A16												
MAMR1	Memory address mask register 1	CBH	V21	V20	V19	V18	V17	V16	V15-V9	V8		
			R/W									
			1	1	1	1	1	1	1	1		
CS1 area size 0: Enable to address comparison												

Chip select/wait control (2/2)

Symbol	Name	Address	7	6	5	4	3	2	1	0
MSAR2	Memory start address register 2	CCH	S23	S22	S21	S20	S19	S18	S17	S16
			R/W							
			1	1	1	1	1	1	1	1
			Start address A23 to A16							
MAMR2	Memory address mask register 2	CDH	V22	V21	V20	V19	V18	V17	V16	V15
			R/W							
			1	1	1	1	1	1	1	1
			CS2 area size 0: Enable to address comparison							
MSAR3	Memory start address register 3	CEH	S23	S22	S21	S20	S19	S18	S17	S16
			R/W							
			1	1	1	1	1	1	1	1
			Start address A23 to A16							
MAMR3	Memory address mask register 3	CFH	V22	V21	V20	V19	V18	V17	V16	V15
			R/W							
			1	1	1	1	1	1	1	1
			CS3 area size 0: Enable to address comparison							

Not Recommended for New Design

(5) Clock gear (1/2)

Symbol	Name	Address	7	6	5	4	3	2	1	0		
SYSCR0	System clock control register 0	E0H	XEN	XTEN	RXEN	RXTEN	RSYSCK	WUEF	PRCK1	PRCK0		
			R/W									
			1	0	1	0	0	0	0	0		
			High-frequency oscillator (fc) 0: Stopped 1: Oscillation	Low-frequency oscillator (fs) 0: Stopped 1: Oscillation	High-frequency oscillator (fc) after release of STOP mode 0: Stopped 1: Oscillation	Low-frequency oscillator (fs) after release of STOP mode 0: Stopped 1: Oscillation	Select clock after release of STOP mode 0: fc 1: fs	Warm-up timer 0 write: Don't care 1 write: Start timer 0 read: End warm up 1 read: Not end warm up	Select prescaler clock 00: f _{FPH} 01: Reserved 10: fc/16 11: Reserved			
SYSCR1	System clock control register 1	E1H	7	6	5	4	SYSCK	GEAR2	GEAR1	GEAR0		
			R/W									
			1	0	1	0	0	1	0	0		
			High-frequency oscillator (fc) after release of STOP mode 0: Stopped 1: Oscillation	Low-frequency oscillator (fs) after release of STOP mode 0: Stopped 1: Oscillation	High-frequency oscillator (fc) after release of STOP mode 0: Stopped 1: Oscillation	Low-frequency oscillator (fs) after release of STOP mode 0: Stopped 1: Oscillation	System clock selection 0: fc 1: fs	High-frequency gear value selection (fc) 000: fc 001: fc/2 010: fc/4 011: fc/8 100: fc/16 101: (Reserved) 110: (Reserved) 111: (Reserved)				
SYSCR2	System clock control register 2	E2H	7	SCOSEL	WUPTM1	WUPTM0	HALTM1	HALTM0	1	DRVE		
			R/W								R/W	
			1	0	1	0	1	1	1	0		
			High-frequency oscillator (fc) after release of STOP mode 0: Stopped 1: Oscillation	0: fs 1: f _{FPH}	Warm-up time 00: Reserved 01: 2 ⁸ input frequency 10: 2 ¹⁴ input frequency 11: 2 ¹⁶ input frequency		00: Reserved 01: STOP mode 10: IDLE1 mode 11: IDLE2 mode		Pin state control in STOP/IDL E1 mode 0: I/O off 1: Remain the state before halt			

Clock gear (2/2)

Symbol	Name	Address	7	6	5	4	3	2	1	0	
EMCCR0	EMC control register 0	E3H	PROTECT	-	-	-	ALEEN	EXTIN	DRVOSCH	DRVOSCL	
			R	R/W							
			0	0	1	0	0	0	1	1	
			Protection flag 0: OFF 1: ON	Always write "0"	Always write "1"	Always write "0"	1: ALE output enable	1: fc external clock	fc oscillator driver ability 1: Normal 0: Weak	fs oscillator driver ability 1: Normal 0: Weak	
EMCCR1	EMC control register 1	E4H	Writing 1FH turns protections off. Writing any value other than 1FH turns protection on.								

Note: EMCCR1

When protect-ON is set to EMCCR1, It is prohibited that following SFRs are written.
(SFR that cannot write)

1. CS/WAIT controller
B0CS, B1CS, B2CS, B3CS, BEXCS,
MSAR0, MSAR1, MSAR2, MSAR3,
MAMR0, MAMR1, MAMR2, MAMR3
2. Clock gear (only EMCCR1 is available to write)
SYSCR0, SYSCR1, SYSCR2, EMCCR0
3. DFM
DFMCR0

(6) DFM (Clock doubler)

Symbol	Name	Address	7	6	5	4	3	2	1	0		
DFMCR0	DFM control register 0	E8H	ACT1	ACT0	DLUPFG	DLUPTM						
			R/W		R	R/W						
			0	0	0	0						
			Always write "0"									
DFMCR1	DFM control register 1	E9H	-	-	-	-	-	-	-	-		
			R/W									
			0	0	0	1	0	0	1	1		
			Don't access this register									

Note: TMP91FY42 does not built-in Clock Doubler (DFM).

(7) 8-bit timer (1/2)

(7-1) TMRA01

Symbol	Name	Address	7	6	5	4	3	2	1	0
TA01RUN	8-bit timer RUN	100H	TA0RDE	 	 	 	I2TA01	TA01PRUN	TA1RUN	TA0RUN
			R/W	 	 	 	R/W			
			0	 	 	 	0	0	0	0
			Double buffer 0: Disable 1: Enable				IDLE2 0: Stop 1: Operate	TMRA01 prescaler 0: Stop and clear 1: Run (Count up)	Up counter (UC1)	Up counter (UC0)
TA0REG	8-bit timer register 0	102H (Prohibit RMW)	-							
			W							
			Undefined							
TA1REG	8-bit timer register 1	103H (Prohibit RMW)	-							
			W							
			Undefined							
TA01MOD	8-bit timer source CLK & mode	104H	TA01M1	TA01M0	PWM01	PWM00	TA1CLK1	TA1CLK0	TA0CLK1	TA0CLK0
			R/W							
			0	0	0	0	0	0	0	0
			Operation mode 00: 8-bit timer 01: 16-bit timer 10: 8-bit PPG 11: 8-bit PWM	PWM cycle 00: Reserved 01: 2 ⁶ 10: 2 ⁷ 11: 2 ⁸	Source clock for TMRA1 00: TA0TRG 01: φT1 10: φT16 11: φT256		Source clock for TMRA0 00: TA0IN pin 01: φT1 10: φT4 11: φT16			
TA1FFCR	8-bit timer flip-flop control	105H (Prohibit RMW)	 	 	 	 	TA1FFC1	TA1FFC0	TA1FFIE	TA1FFIS
			R/W							
							1	1	0	0
							00: Invert TA1FF 01: Set TA1FF 10: Clear TA1FF 11: Don't care	TA1FF control for inversion 0: Disable 1: Enable	TA1FF inversion select 0: TMRA0 1: TMRA1	

(7-2) TMRA23

Symbol	Name	Address	7	6	5	4	3	2	1	0
TA23RUN	8-bit timer RUN	108H	TA2RDE	 	 	 	I2TA23	TA23PRUN	TA3RUN	TA2RUN
			R/W	 	 	 	R/W			
			0	 	 	 	0	0	0	0
			Double buffer 0: Disable 1: Enable				IDLE2 0: Stop 1: Operate	TMRA23 prescaler 0: Stop and clear 1: Run (Count up)	Up counter (UC3)	Up counter (UC2)
TA2REG	8-bit timer register 0	10AH (Prohibit RMW)	-							
			W							
			Undefined							
TA3REG	8-bit timer register 1	10BH (Prohibit RMW)	-							
			W							
			Undefined							
TA23MOD	8-bit timer source CLK & mode	10CH	TA23M1	TA23M0	PWM21	PWM20	TA3CLK1	TA3CLK0	TA2CLK1	TA2CLK0
			R/W							
			0	0	0	0	0	0	0	0
			Operation mode 00: 8-bit timer 01: 16-bit timer 10: 8-bit PPG 11: 8-bit PWM	PWM cycle 00: Reserved 01: 2 ⁶ 10: 2 ⁷ 11: 2 ⁸	Source clock for TMRA3 00: TA2TRG 01: φT1 10: φT16 11: φT256		Source clock for TMRA2 00: Reserved 01: φT1 10: φT4 11: φT16			
TA3FFCR	8-bit timer flip-flop control	10DH (Prohibit RMW)	 	 	 	 	TA3FFC1	TA3FFC0	TA3FFIE	TA3FFIS
			R/W							
							1	1	0	0
							00: Invert TA3FF 01: Set TA3FF 10: Clear TA3FF 11: Don't care	TA3FF control for inversion 0: Disable 1: Enable	TA3FF inversion select 0: TMRA2 1: TMRA3	

8-bit timer (2/2)

(7-3) TMRA45

Symbol	Name	Address	7	6	5	4	3	2	1	0		
TA45RUN	8-bit timer RUN	110H	TA4RDE				I2TA45	TA45PRUN	TA5RUN	TA4RUN		
			R/W				R/W					
			0				0	0	0	0		
			Double buffer 0: Disable 1: Enable				IDLE2 0: Stop 1: Operate	TMRA45 prescaler 0: Stop and clear 1: Run (Count up)	Up counter (UC5)	Up counter (UC4)		
TA4REG	8-bit timer register 0	112H (Prohibit RMW)	-							W	Undefined	
TA5REG	8-bit timer register 1	113H (Prohibit RMW)	-							W	Undefined	
TA45MOD	8-bit timer source CLK & mode	114H	TA45M1	TA45M0	PWM41	PWM40	TA5CLK1	TA5CLK0	TA4CLK1	TA4CLK0		
			R/W									
			0	0	0	0	0	0	0	0		
			Operation mode 00: 8-bit timer 01: 16-bit timer 10: 8-bit PPG 11: 8-bit PWM	PWM cycle 00: Reserved 01: 2 ⁶ 10: 2 ⁷ 11: 2 ⁸	Source clock for TMRA5 00: TA4TRG 01: φT1 10: φT16 11: φT256	Source clock for TMRA4 00: TA4IN pin 01: φT1 10: φT4 11: φT16						
TA5FFCR	8-bit timer flip-flop control	115H (Prohibit RMW)					TA5FFC1	TA5FFC0	TA5FFIE	TA5FFIS		
			R/W									
							1	1	0	0		
							00: Invert TA5FF 01: Set TA5FF 10: Clear TA5FF 11: Don't care	TA5FF control for inversion 0: Disable 1: Enable	TA5FF inversion select 0: TMRA4 1: TMRA5			

(7-4) TMRA67

Symbol	Name	Address	7	6	5	4	3	2	1	0		
TA67RUN	8-bit timer RUN	118H	TA6RDE				I2TA67	TA67PRUN	TA7RUN	TA6RUN		
			R/W				R/W					
			0				0	0	0	0		
			Double buffer 0: Disable 1: Enable				IDLE2 0: Stop 1: Operate	TMRA67 prescaler 0: Stop and clear 1: Run (Count up)	Up counter (UC1)	Up counter (UC0)		
TA6REG	8-bit timer register 0	11AH (Prohibit RMW)	-							W	Undefined	
TA7REG	8-bit timer register 1	11BH (Prohibit RMW)	-							W	Undefined	
TA67MOD	8-bit timer source CLK & mode	11CH	TA67M1	TA67M0	PWM61	PWM60	TA7CLK1	TA7CLK0	TA6CLK1	TA6CLK0		
			R/W									
			0	0	0	0	0	0	0	0		
			Operation mode 00: 8-bit timer 01: 16-bit timer 10: 8-bit PPG 11: 8-bit PWM	PWM cycle 00: Reserved 01: 2 ⁶ PWM cycle 10: 2 ⁷ 11: 2 ⁸	Source clock for TMRA7 00: TA6TRG 01: φT1 10: φT16 11: φT256	Source clock for TMRA6 00: Reserved 01: φT1 10: φT4 11: φT16						
TA7FFCR	8-bit timer flip-flop control	11DH (Prohibit RMW)					TA7FFC1	TA7FFC0	TA7FFIE	TA7FFIS		
			R/W									
							1	1	0	0		
							00: Invert TA7FF 01: Set TA7FF 10: Clear TA7FF 11: Don't care	TA7FF control for inversion 0: Disable 1: Enable	TA7FF inversion select 0: TMRA6 1: TMRA7			

(8) 16-bit timer (1/2)

(8-1) TMRB0

Symbol	Name	Address	7	6	5	4	3	2	1	0
TB0RUN	16-bit timer control	180H	TB0RDE	–			I2TB0	TB0PRUN		TB0RUN
			R/W				R/W			
			0	0			0	0		0
			Double buffer 0: Disable 1: Enable	Always write "0"			IDLE2 0: Stop 1: Operate	TMRB0 prescaler 0: Stop and clear 1: Run (Count up)		Up counter (UC10)
TB0MOD	16-bit timer source CLK & mode	182H (Prohibit RMW)	TB0CT1	TB0ET1	TB0CP0I	TB0CPM1	TB0CPM0	TB0CLE	TB0CLK1	TB0CLK0
			R/W		W*			R/W		
			0	0	1	0	0	0	0	0
			TB0FF1 Inversion trigger 0: Trigger disable 1: Trigger enable	Software capture control	Capture timing 00: Disable 01: TB0IN0 ↑ TB0IN1 ↑ 10: TB0IN0 ↑ TB0IN0 ↓ 11: TA1OUT ↑ TA1OUT ↓ INT5 is rising edge	Up counter control 0: Clear 1: Clear enable	TMRB0 source clock select 00: TB0IN0 pin input 01: φT1 10: φT4 11: φT16			
TB0FFCR	16-bit timer flip-flop control	183H (Prohibit RMW)	TB0FF1C1	TB0FF1C0	TB0CT1I	TB0C0T1	TB0E1T1	TB0E0T1	TB0FF0C1	TB0FF0C0
			W*		R/W		W*			
			1	1	0	0	0	0	1	1
			TB0FF1 control 00: Invert 01: Set 10: Clear 11: Don't care Always read as "11".	TB0FF0 inversion trigger 0: Trigger disable 1: Trigger enable	Invert when the UC10 value is loaded in to TB0CP1H/L.	Invert when the UC10 value is loaded in to TB0CP0H/L.	Invert when the UC10 matches with TB0RG1H/L.	Invert when the UC10 match with TB0RG0H/L.	TB0FF0 Control 00: Invert 01: Set 10: Clear 11: Don't care Always read as "11".	
TB0RG0L	16-bit timer register 0L	188H (Prohibit RMW)	–		W		Undefined			
TB0RG0H	16-bit timer register 0H	189H (Prohibit RMW)	–		W		Undefined			
TB0RG1L	16-bit timer register 1L	18AH (Prohibit RMW)	–		W		Undefined			
TB0RG1H	16 bit timer register 1H	18BH (Prohibit RMW)	–		W		Undefined			
TB0CP0L	Capture register 0L	18CH	–		R		Undefined			
TB0CP0H	Capture register 0H	18DH	–		R		Undefined			
TB0CP1L	Capture register 1L	18EH	–		R		Undefined			
TB0CP1H	Capture register 1H	18FH	–		R		Undefined			

16-bit timer (2/2)

(8-2) TMRB1

Symbol	Name	Address	7	6	5	4	3	2	1	0	
TB1RUN	16-bit timer control	190H	TB1RDE	–			I2TB1	TB1PRUN		TB1RUN	
			R/W				R/W			R/W	
			0	0			0	0		0	
			Double buffer 0: Disable 1: Enable	Always write "0"			IDLE2 0: Stop 1: Operate	TMRB1 prescaler 0: Stop and clear 1: Run (Count up)		Up counter (UC12)	
TB1MOD	16-bit timer source CLK & mode	192H (Prohibit RMW)	TB1CT1	TB1ET1	TB1CP0L	TB1CPM1	TB1CPM0	TB1CLE	TB1CLK1	TB1CLK0	
			R/W		W*			R/W			
			0	0	1	0	0	0	0	0	0
			TB1FF1 Inversion trigger 0: Trigger disable 1: Trigger enable		Software capture control 0: Software capture 1: Undefined	Capture timing 00: Disable INT7 is rising edge 01: TB1IN0 ↑ TB1IN1 ↑ INT7 is rising edge 10: TB1IN0 ↑ TB1IN0 ↓ INT7 is falling edge 11: TA1OUT ↑ TA1OUT ↓ INT7 is rising edge		Up counter control 0: Clear 1: Clear enable	TMRB0 source clock select 00: TB1IN0 pin input 01: φT1 10: φT4 11: φT16		
TB1FFCR	16-bit timer flip-flop control	193H (Prohibit RMW)	TB1FF1C1	TB1FF1C0	TB1C1T1	TB1C0T1	TB1E1T1	TB1E0T1	TB1FF0C1	TB1FF0C0	
			W*		R/W				W*		
			1	1	0	0	0	0	1	1	
			TB1FF1 control 00: Invert 01: Set 10: Clear 11: Don't care Always read as "11".		TB1FF0 inversion trigger 0: Trigger disable 1: Trigger enable Invert when the UC12 value is loaded in to TB1CP1H/L				Invert when the UC12 value is loaded in to TB1CP0H/L		Invert when the UC12 matches with TB1RG0H/L
TB1RG0L	16-bit timer register 0L	198H (Prohibit RMW)	– W Undefined								
TB1RG0H	16-bit timer register 0H	199H (Prohibit RMW)	– W Undefined								
TB1RG1L	16-bit timer register 1L	19AH (Prohibit RMW)	– W Undefined								
TB1RG1H	16-bit timer register 1H	19BH (Prohibit RMW)	– W Undefined								
TB1CP0L	Capture register 0L	19CH	– R Undefined								
TB1CP0H	Capture register 0H	19DH	– R Undefined								
TB1CP1L	Capture register 1L	19EH	– R Undefined								
TB1CP1H	Capture register 1H	19FH	– R Undefined								

(9) UART/Serial chanel (1/2)

(9-1) UART/SIO Channel0

Symbol	Name	Address	7	6	5	4	3	2	1	0		
SC0BUF	Serial channel 0 buffer	200H (Prohibit RMW)	RB7/TB7	RB6/TB6	RB5/TB5	RB4/TB4	RB3/TB3	RB2/TB2	RB1/TB1	RB0/TB0		
			R (Receiving)/W (Transmission)									
			Undefined									
SC0CR	Serial channel 0 control	201H	RB8	EVEN	PE	OERR	PERR	FERR	SCLKS	IOC		
			R	R/W		R (Cleared to 0 when read)			R/W			
			Undefined	0	0	0	0	0	0	0		
			Received data bit8	Parity 0: Odd 1: Even	Parity addition 0: Disable 1: Enable	Overrun	Parity	Framing	0: SCLK0↑ 1: SCLK0↓	0: Baud rate generator 1: SCL0 pin input		
SC0MOD0	Serial channel 0 mode0	202H	TB8	CTSE	RXE	WU	SM1	SM0	SC1	SC0		
			R/W									
			0	0	0	0	0	0	0	0		
			Transmission data bit8	Handshake 0: CTS disable 1: CTS enable	Receive function 0: Receive disable 1: Receive enable	Wakeup function 0: Disable 1: Enable	Serial transmission mode 00: I/O interface mode 01: 7-bit UART mode 10: 8-bit UART mode 11: 9-bit UART mode	Serial transmission clock (UART) 00: TA0TRG 01: Baud rate generator 10: Internal clock fsys 11: External clock SCLK0				
BR0CR	Baud rate control	203H	-	BR0ADDE	BR0CK1	BR0CK0	BR0S3	BR0S2	BR0S1	BR0S0		
			R/W									
			0	0	0	0	0	0	0	0		
			Always write "0".	+ (16 - K)/16 division 0: Disable 1: Enable	00: φT0 01: φT2 10: φT8 11: φT32	Divided frequency setting						
BR0ADD	Serial channel 0 K setting register	204H					BR0K3	BR0K2	BR0K1	BR0K0		
			R/W									
			0	0	0	0	0	0	0	0		
			Set frequency divisor K (divided by N + (16 - K)/16).									
SC0MOD1	Serial channel 0 mode1	205H	I2S0	FDPX0								
			R/W									
			0	0								
IDLE2	Duplex											
0: Stop	0: Half											
1: Operate	1: Full											

(9-2) IrDA

Symbol	Name	Address	7	6	5	4	3	2	1	0		
SIRCR	IrDA control register	207H	PLSEL	RXSEL	TXEN	RXEN	SIRWD3	SIRWD1	SIRWD1	SIRWD0		
			R/W									
			0	0	0	0	0	0	0	0		
			Transmission pulse width 0: 3/16 1: 1/16	Receiving data 0: H pulse 1: L pulse	Transmission 0: Disable 1: Enable	Receiving 0: Disable 1: Enable	Set the effective SIRRx D pulse width Pulse width more than 2x × (Set value + 1) + 100 ns Possible: 1 to 14 Not possible: 0, 15					

UART/Serial channel (2/2)

(9-3) UART/SIO Channel1

Symbol	Name	Address	7	6	5	4	3	2	1	0		
SC1BUF	Serial channel 1 buffer	208H (Prohibit RMW)	RB7/TB7	RB6/TB6	RB5/TB5	RB4/TB4	RB3/TB3	RB2/TB2	RB1/TB1	RB0/TB0		
			R (Receiving)/W (Transmission)									
			Undefined									
SC1CR	Serial channel 1 control	209H	RB8	EVEN	PE	OERR	PERR	FERR	SCLKS	IOC		
			R	R/W		R (Cleared to 0 when read)			R/W			
			Undefined	0	0	0	0	0	0	0		
			Received data bit8	Parity 0: Odd 1: Even	Parity addition 0: Disable 1: Enable	Overrun	Parity	Framing	0: SCLK0↑ 1: SCLK0↓	0: Baud rate generator 1: SCLK1 pin input		
SC1MOD0	Serial channel 1 mode	20AH	TB8	CTSE	RXE	WU	SM1	SM0	SC1	SC0		
			R/W									
			0	0	0	0	0	0	0	0		
			Transmission data bit8	Handshake 0: CTS disable 1: CTS enable	Receive function 0: Receive disable 1: Receive enable	Wakeup function 0: Disable 1: Enable	Serial transmission mode 00: I/O interface mode 01: 7-bit UART mode 10: 8-bit UART mode 11: 9-bit UART mode	Serial transmission clock (UART) 00: TA0TRG 01: Baud rate generator 10: Internal clock f _{sys} 11: External clock SCLK1				
BR1CR	Baud rate control	20BH	-	BR1ADDE	BR1CK1	BR1CK0	BR1S3	BR1S2	BR1S1	BR1S0		
			R/W									
			0	0	0	0	0	0	0	0		
			Always write "0".	+ (16 - K)/16 division 0: Disable 1: Enable	00: φT0 01: φT2 10: φT8 11: φT32	Divided frequency setting						
BR1ADD	Serial channel 1 K setting register	20CH	 	 	 	 	BR1K3	BR1K2	BR1K1	BR1K0		
			R/W									
			 	 	 	 	0	0	0	0		
			Set frequency divisor K (divided by N + (16 - K)/16).									
SC1MOD1	Serial channel 1 mode 1	20DH	I2S1	FDPX1	 	 	 	 	 	 		
			R/W									
			0	0	 	 	 	 	 	 		
			IDLE2 0: Stop 1: Operate	Duplex 0: Half 1: Full	 	 	 	 	 	 		

(10) I²C bus/serial interface (1/2)

Symbol	Name	Address	7	6	5	4	3	2	1	0	
SBI0CR1	Serial bus interface control register 1	240H (I ² C bus mode) (Prohibit RMW)	BC2	BC1	BC0	ACK		SCK2	SCK1	SCK0 /SWRMON	
			W			R/W		W			R/W
			0	0	0	0		0	0	0/1	
		Number of transfer bits 000: 8 001: 1 010: 2 011: 3 100: 4 101: 5 110: 6 111: 7			Acknowledge mode 0: Disable 1: Enable		Setting for the divisor value n 000: 5 001: 6 010: 7 011: 8 100: 9 101: 10 110: 11 111: (Reserved)				
		240H (SIO mode) (Prohibit RMW)	SIOS	SIOINH	SIOM1	SIOM0		SCK2	SCK1	SCK0	
			W			W					
0	0		0	0	0	0		0			
Transfer 0: Stop 1: Start			Transfer 0: Continue 1: Abort		Transfer mode 00: 8-bit transmit mode 10: 8-bit transmit/receive mode 11: 8-bit received mode		Setting for the divisor value n 000: 4 001: 5 010: 6 011: 7 100: 8 101: 9 110: 10 111: SCK pin				
SBI0DBR	SBI buffer register	241H (Prohibit RMW)	DB7	DB6	DB5	DB4	DB3	DB2	DB1	DB0	
			R (Receiving)/W (Transmission)								
			Undefined								
I2C0AR	I ² C bus address register	242H (Prohibit RMW)	SA6	SA5	SA4	SA3	SA2	SA1	SA0	ALS	
			W								
			0	0	0	0	0	0	0	0	0
Setting slave address									Address recognition 0: Enable 1: Disable		
When read SBI0SR	Serial bus interface status register	243H (I ² C bus mode) (Prohibit RMW)	MST	TRX	BB	PIN	AL/SBIM1	AAS/SBIM0	AD0/SWRST1	LRB/SWRST0	
			R/W								
			0	0	0	1	0	0	0	0	
0: Slave 1: Master			0: Receiver 1: Transmit		Bus status monitor 0: Free 1: Busy	INTSBI request monitor 0: Request 1: Cancel	Arbitration lost detection monitor 1: Detect	Slave address match detection monitor 1: Detect	GENERAL CALL detection monitor 1: Detect	Lost receive bit monitor 0: 0 1: 1	
When write SBI0CR2	Serial bus interface control register 2		Start/stop condition generation 0: Start condition 1: Stop condition		Serial bus interface operating mode selection 00: Port mode 01: SIO mode 10: I2C bus mode 11: (Reserved)		Software reset generate write "10" and "01", then an internal reset signal is generated.				
When read SBI0SR	Serial bus interface status register	243H (SIO mode) (Prohibit RMW)					SIOF/SBIM1	SEF/SBIM0	-	-	
			R/W								
			0	0	0	0	0	0			
Transfer status monitor 0: Stopped 1: Terminated in process			Shift operation status monitor 0: Stopped 1: Terminated in process								
When write SBI0CR2	Serial bus interface control register 2						Serial bus interface operating mode selection 00: Port mode 01: SIO mode 10: I2C bus mode 11: (Reserved)		Always write "0".	Always write "0".	

I2C bus/serial interface (2/2)

Symbol	Name	Address	7	6	5	4	3	2	1	0
SBI0BR0	Serial bus Interface baud rate register 0	244H (Prohibit RMW)	-	I2SBI0						
			W	R/W						
			0	0						
			Always write "0".	IDLE2 0: Abort 1: Operate						
SBI0BR1	Serial bus interface baud rate register 1	245H (Prohibit RMW)	P4EN	-						
				W						
			0	0						
			Clock control 0: Stop 1: Operate	Always write "0".						

Not Recommended for New Design

(11) AD converter

Symbol	Name	Address	7	6	5	4	3	2	1	0		
ADMOD0	AD mode register 0	2B0H	EOCF	ADBF	-	-	ITM0	REPEAT	SCAN	ADS		
			R			R/W						
			0	0	0	0	0	0	0	0	0	
			AD conversion end flag 1: End	AD conversion burst flag 1: Busy	Always write 0	Always write 0	Interrupt in repeat mode	Repeat mode specification 1: Repeat	Scan mode specification 1: Scan	AD conversion Star 1: Start		
ADMOD1	AD mode register 1	2B1H	VREFON	I2AD			ADTRGE	ADCH2	ADCH1	ADCH0		
			R/W			R/W						
			0	0			0	0	0	0		
			VREF control 0: OFF 1: ON	IDLE2 0: Abort 1: Operate			AD control 1: Enable for External start	Input channel 000: AN0 AN0 001: AN1 AN0 → AN1 010: AN2 AN0 → AN1 → AN2 011: AN3 AN0 → AN1 → AN2 → AN3 100: AN4 AN4 101: AN5 AN4 → AN5 110: AN6 AN4 → AN5 → AN6 111: AN7 AN4 → AN5 → AN6 → AN7				
ADREG04L	AD result register 0/4 low	2A0H	ADR01	ADR00						ADR0RF		
			R			R						
			Undefined			0						
ADREG04H	AD result register 0/4 high	2A1H	ADR09	ADR08	ADR07	ADR06	ADR05	ADR04	ADR03	ADR02		
			R								Undefined	
ADREG15L	AD result register 1/5 low	2A2H	ADR11	ADR10						ADR1RF		
			R			R						
			Undefined			0						
ADREG15H	AD result register 1/5 high	2A3H	ADR19	ADR18	ADR17	ADR16	ADR15	ADR14	ADR13	ADR12		
			R								Undefined	
ADREG26L	AD result register 2/6 low	2A4H	ADR21	ADR20						ADR2RF		
			R			R						
			Undefined			0						
ADREG26H	AD result register 2/6 high	2A5H	ADR29	ADR28	ADR27	ADR26	ADR25	ADR24	ADR23	ADR22		
			R								Undefined	
ADREG37L	AD result register 3/7 low	2A6H	ADR31	ADR30						ADR3RF		
			R			R						
			Undefined			0						
ADREG37H	AD result register 3/7 high	2A7H	ADR39	ADR38	ADR37	ADR36	ADR35	ADR34	ADR33	ADR32		
			R								Undefined	

(12) Watchdog timer

Symbol	Name	Address	7	6	5	4	3	2	1	0	
WDMOD	WDT mode register	300H	WDTE	WDTP1	WDTP0			I2WDT	RESCR	-	
			R/W			R/W					
			1	0	0			0	0	0	
			WDT control 1: Enable	Select detecting time 00: $2^{15}/f_{SYS}$ 01: $2^{17}/f_{SYS}$ 10: $2^{19}/f_{SYS}$ 11: $2^{21}/f_{SYS}$					IDLE2 0: Stop 1: Operate	1: Internally connects WDL out to the reset pin	Always write 0
WDCR	WDT control	301H (Prohibit RMW)	-								
			W								
			-								
			B1H: WDT disable code 4EH: WDT clear code								

(13) Special timer for CLOCK

Symbol	Name	Address	7	6	5	4	3	2	1	0
RTCCR	RTC control register	310H	-					RTCSEL1	RTCSEL0	RTCRUN
			R/W				R/W			
			0					0	0	0
			Always write "0".					00: $2^{14}/f_s$ 01: $2^{13}/f_s$ 10: $2^{12}/f_s$ 11: $2^{11}/f_s$	0: Stop & clear 1: Count	

Not Recommended for New Design

6. Port Section Equivalent Circuit Diagrams

- Reading the circuit diagrams

Basically, the gate symbols written are the same as those used for the standard CMOS logic IC [74HCXX] series.

The dedicated signal is described below.

STOP : This signal becomes active 1 when the HALT mode setting register is set to the STOP mode (SYSCR2<HALTM1:0> = "01") and the CPU executes the HALT instruction.

When the drive enable bit SYSCR2<DRVE> is set to "1", however STOP remains at "0".

- The input protection resistance ranges from several tens of ohms to several hundreds of ohms.
- P0 (AD0~AD7), P1 (AD8~AD15, A8~A15), P2 (A16~A23, A0~A7), P60, P64~P66, P70~P75, P80~P87, P91~P92, P94~P95, PA0~PA7

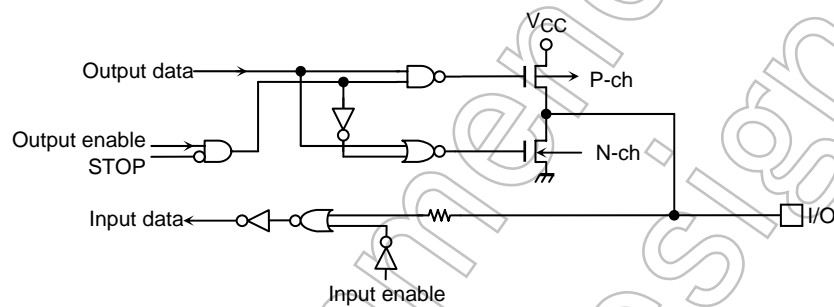

- P30 (\overline{RD}), P31 (\overline{WR})

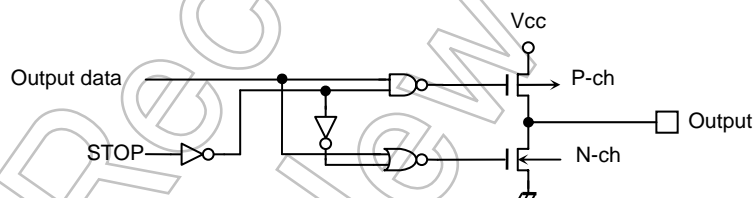

■ P32~P37, P40~P43

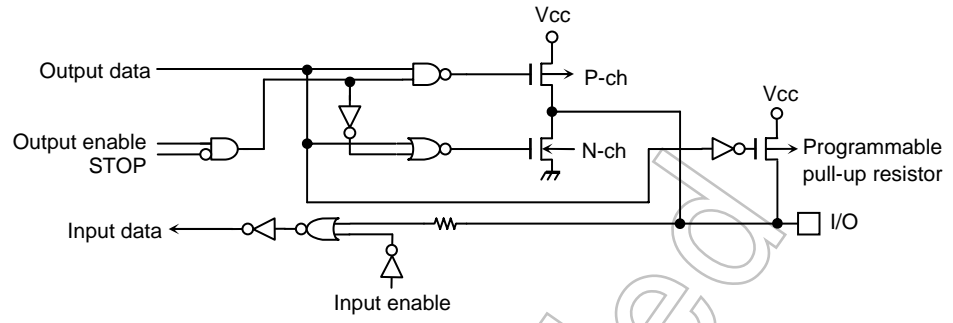

■ P5 (AN0~AN7)

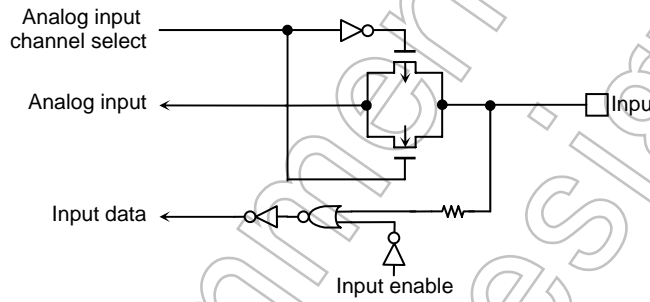

■ P63 (INT0)

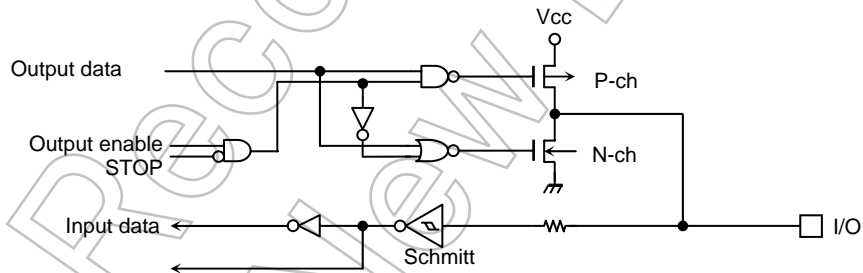

■ P61 (SO/SDA), P62 (SI/SCL), P90 (TXD0), P93 (TXD1)

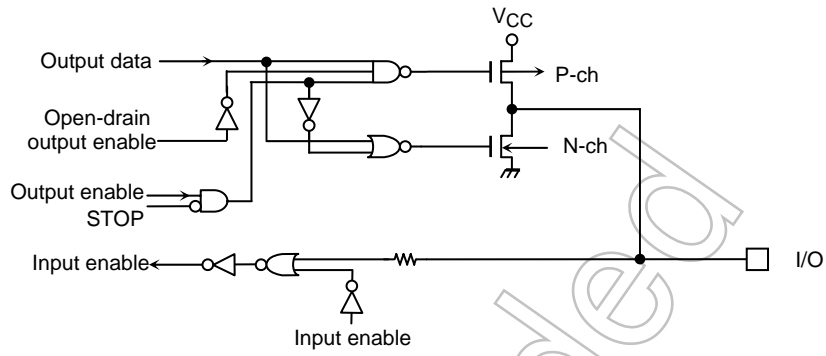

■ P96 (XT1), P97 (XT2)

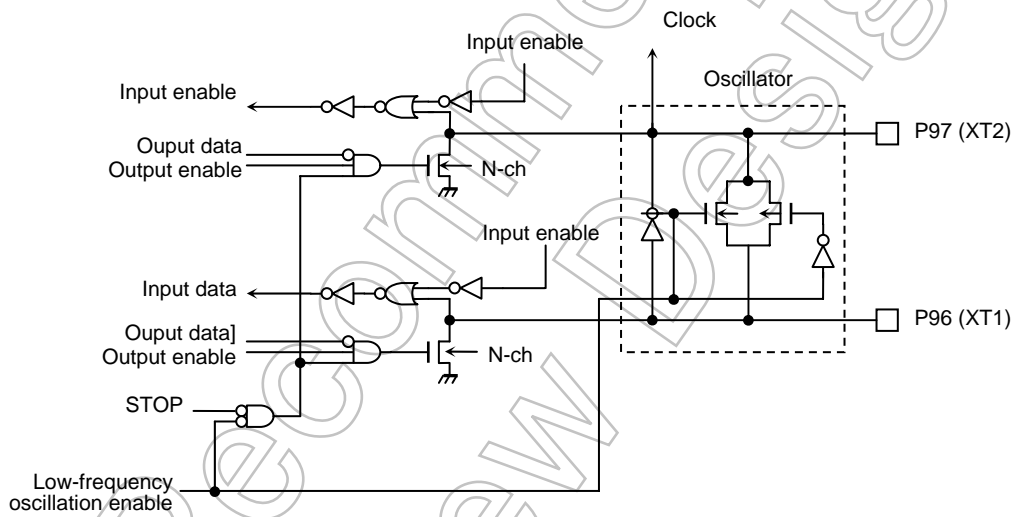

■ $\overline{\text{NMI}}$



■ AM0~AM1

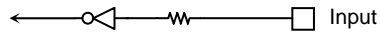

■ ALE

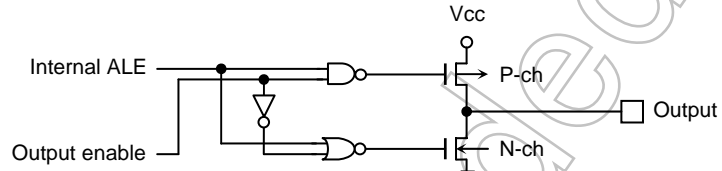

■ RESET

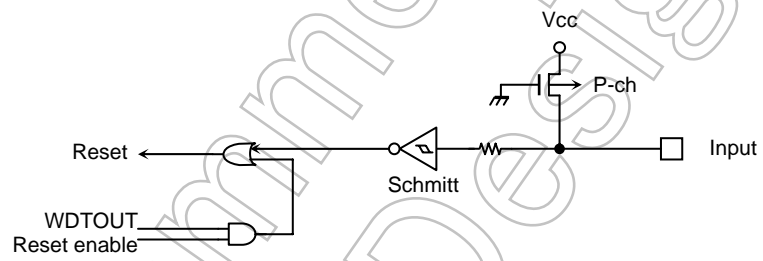

■ X1, X2

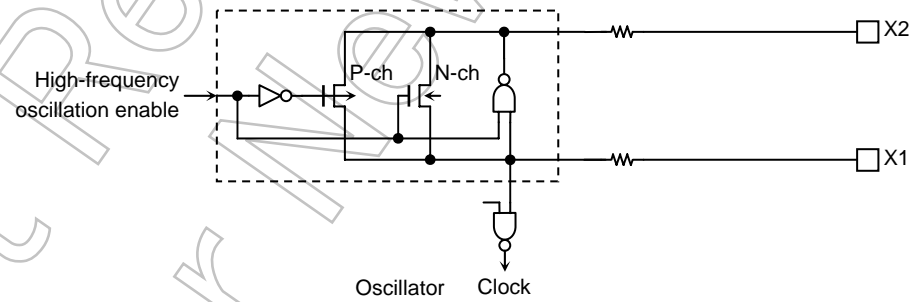

■ VREFH, VREFL

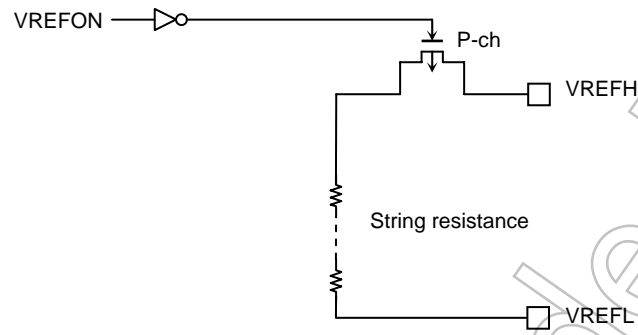

Not Recommended for New Design

7. Points to Note and Restrictions

(1) Notation

- a. The notation for built-in I/O registers is as follows register symbol <Bit symbol>
e.g.) TA01RUN<TA0RUN> denotes bit TA0RUN of register TA01RUN.
- b. Read-modify-write instructions

An instruction in which the CPU reads data from memory and writes the data to the same memory location in one instruction.

Example 1: SET 3, (TA01RUN) ... Set bit3 of TA01RUN.

Example 2: INC 1, (100H) ... Increment the data at 100H.

- Examples of read-modify-write instructions on the TLCS-900

Exchange instruction

EX (mem), R

Arithmetic operations

ADD (mem), R# ADC (mem), R/#

SUB (mem), R# SBC (mem), R/#

INC #3, (mem) DEC #3, (mem)

Logic operations

AND (mem), R# OR (mem), R/#

XOR (mem), R#

Bit manipulation operations

STCF #3/A, (mem) RES #3, (mem)

SET #3, (mem) CHG #3, (mem)

TSET #3, (mem)

Rotate and shift operations

RLC (mem) RRC (mem)

RL (mem) RR (mem)

SLA (mem) SRA (mem)

SLL (mem) SRL (mem)

RLD (mem) RRD (mem)

- c. fc, fs, fFPH, fSYS and one state

The clock frequency input on pins X1 and 2 is called fOSCH. The clock selected by DFMCRO<ACT1:0> is called fc.

The clock selected by SYSCR1<SYSCK> is called fFPH. The clock frequency give by fFPH divided by 2 is called fSYS.

One cycle of fSYS is referred to as one state.

(2) Points of note

a. AM0 and AM1 pins

This pin is connected to the DV_{cc} pin. Do not alter the level when the pin is active.

b. EMU0 and EMU1

Open pins.

c. Reserved address areas

The TMP91FY24 does not have any reserved areas.

d. HALT mode (IDLE1)

When IDLE1 mode (in which oscillator operation only occurs) is used, set RTCCR<RTCRUN> to 0 stop the Special timer for CLOCK before the HALT instructions is executed.

e. Warm-up counter

The warm-up counter operates when STOP mode is released, even if the system is using an external oscillator. As a result a time equivalent to the warm-up time elapses between input of the release request and output of the system clock.

f. Programmable pull-up/pull-down resistances

The programmable pull-up/pull-down resistor can be turned ON/OFF by a program when the ports are set for use as input ports. When the ports are set for use as output ports, they cannot be turned on/off by a program.

The data registers (e.g., P6) are used to turn the pull-up/pull-down resistors ON/OFF. Consequently read-modify-write instructions are prohibited.

g. Bus release function

It is described note point in 3.5 "Port Function" that pin's conditions at bus release condition. Please refer that.

h. Watchdog timer

The watchdog timer starts operation immediately after a reset is released. When the watchdog timer is not to be used, disable it.

When the bus is released, neither internal memory nor internal I/O can be accessed. However, the internal I/O continues to operate. Hence the watchdog timer continues to run. Therefore be careful about the bus releasing time and set the detection timer of watchdog timer.

i. AD converter

The string resistor between the VREFH and VREFL pins can be cut by a program so as to reduce power consumption. When STOP mode is used, disable the resistor using the program before the HALT instruction is executed.

j. CPU (Micro DMA)

Only the LDC cr, r and LDC r, cr instructions can be used to access the control registers in the CPU (e.g., the transfer source address register (DMASn)).

k. Undefined SFR

The value of an undefined bit in an SFR is undefined when read.

l. POP SR instruction

Please execute the POP SR instruction during DI condition.

m. Releasing the HALT mode by requesting an interruption

Usually, interrupts can release all halts status. However, the interrupts ($\overline{\text{NMI}}$, INT0 to INT4, INTRTC) which can release the HALT mode may not be able to do so if they are input during the period CPU is shifting to the HALT mode (for about 5 clocks of f_{FPH}) with IDLE1 or STOP mode (IDLE2 is not applicable to this case). (In this case, an interrupt request is kept on hold internally.)

If another interrupt is generated after it has shifted to HALT mode completely, halt status can be released without difficulty. The priority of this interrupt is compared with that of the interrupt kept on hold internally, and the interrupt with higher priority is handled first followed by the other interrupt.

Not Recommended
for New Design

8. Package Dimensions

LQFP100-P-1414-0.50F

Unit: mm

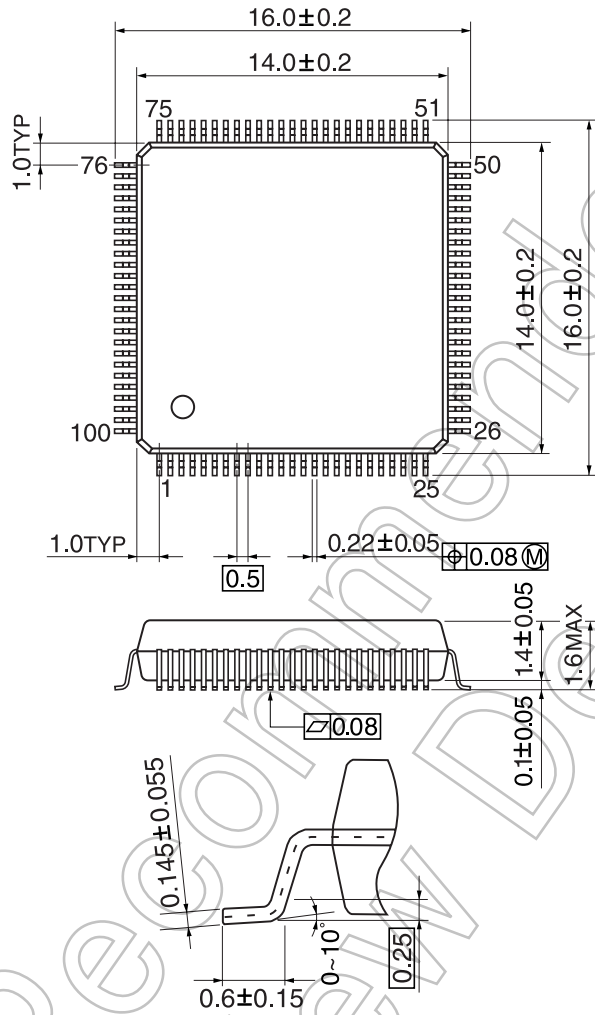

Not Recommended for New Design

Not Recommended
for New Design