

MN10 SERIES NAS HDD

Toshiba MN10 series of 3.5-inch ^[1] 7200 rpm hard disk drives (HDD) deliver up to 20 TB ^[2] of storage capacity, making it higher storage capacities as work-from-home customers need fast access to data and the ability to archive and share data in private cloud environments.

Toshiba's leadership in precision industrial laser welding technology is put to use to permanently seal helium inside the 10-disk mechanics.

To address NAS-class requirements, MN10 series provide 1.2 million hours MTTF / MTBF ^[16] 300 TB/year workload rating and support 24/7 power-on operation.



Product image may represent a design model.

KEY FEATURES

- 20 TB Capacity
- 7200 rpm Performance
- SATA 6.0 Gbit/s ^[3] Interface
- MTTF / MTBF of 1 200 000 hours
- 300 total TB Transferred per Year Workload Rating ^[17]
- Rotational Vibration (RV) Sensors for Great Scalability and Good Performance
- 24/7 operation

APPLICATIONS

- Home and SOHO NAS
- Small business server and storage
- Archiving and data back-up
- Private cloud storage

SPECIFICATION

Item		MN10ACA20T
Interface		SATA-3.3
Formatted Capacity ^[2]		20 TB
Performance	Interface Speed ^[3]	6.0 Gbit/s, 3.0 Gbit/s, 1.5 Gbit/s
	Rotation Speed	7200 rpm
	Buffer Size ^[4]	512 MiB
	Maximum Sustained Data Transfer Speed ^[6] (Typ.)	268 MiB/s
Logical Data Block Length ^[6]		HOST 512 B, DISK 4096 B
Supply Voltage	Allowable Voltage	12 V ^[7] ±10 % / 5 V ^[7] +10 % / -7 % ^[8]
Power Consumption	Random R/W ^[9] (Typ.)	8.02 W
	Active Idle (Typ.)	4.41 W
Acoustics ^[11] (Sound Power)	Active Idle (Typ.)	20 dB
	Seek (Typ.)	32 dB

ENVIRONMENTAL LIMITS

Item		Specification
Enclosure surface temperature	Operating	5 °C to 60 °C (No condensation)
Ambient temperature	Non-Operating ^[11]	-40 °C to 70 °C (No condensation)
Relative Humidity	Operating	5 % to 90 % R.H. (No condensation)
	Non-Operating ^[11]	5 % to 95 % R.H. (No condensation)
Altitude	Operating	-305 m to 3048 m
	Non-Operating ^[14]	-305 m to 12 192 m
Shock ^[12]	Operating	490 m/s ² { 50 G } (2 ms duration)
	Non-Operating	1960 m/s ² { 200 G } (2 ms duration)
Vibration ^{[12][13]}	Operating	7.35 m/s ² { 0.75 G } (5 to 300 Hz) 2.45 m/s ² { 0.25 G } (300 to 500 Hz)
	Non-Operating ^[15]	29.4 m/s ² { 3.0 G } (5 to 500 Hz)

RELIABILITY

Item	Specification
MTTF / MTBF (AFR) ^[16]	1 200 000 hours (0.73 %)
Non-recoverable Error Rate	1 per 10 ¹⁵ bits read
Load / Unload	600 000 times
Availability	24 hours/day, 7 days/week
Rated Annual Workload ^[17]	300 TB per year

[1] "3.5-inch" mean the form factor of HDDs. They do not indicate drive's physical size.

[2] Definition of capacity: Toshiba defines a terabyte (TB) as 1 000 000 000 000 bytes. A computer operating system, however, reports storage capacity using powers of 2 for the definition of 1TB = 2⁴⁰ = 1 099 511 627 776 bytes and therefore shows less storage capacity. Available storage capacity (including examples of various media files) will vary based on file size, formatting, settings, software and operating system, such as Microsoft Operating System and/or pre-installed software applications, or media content. Actual formatted capacity may vary.

[3] Read and write speed may vary depending on the host device, read and write conditions, and file size.

[4] A mebibyte (MiB) means 2²⁰, or 1 048 576 bytes.

[5] The maximum sustained data rate and interface speed may be restricted to the response speed of host system and by transmission characteristics. 1 Gbit/s = 1 000 000 000 bits/s. 1 MiB/s = 1 048 576 bytes/s

[6] Read-modify-write is supported.

[7] Input voltages are specified at the HDD connector side, during HDD ready state.

[8] Make sure the value is not less than -0.3 V DC (less than -0.6 V, 0.1 ms) when turning on or off the power.

[9] Operating watt is measured using 80 % random read / write and 20% performance idle.

[10] The measuring method is based on ISO 7779.

[11] Non-operating condition (except storage condition) assumes short term transportation.

[12] Vibration applied to the HDD is measured at near the mounting screw hole on the frame as much as possible.

[13] At random seek write/read and default on retry setting with log sweep vibration.

[14] The range of altitude is 3048 m or less. Up to 55 °C at 7620 m. Up to 40 °C at 12 192 m.

[15] At power-off state after installation

[16] MTTF / MTBF (Mean Time to Failure / Mean Time Between Failures) of the HDDs during its life time is 1 200 000 hours and AFR (Annualized Failure Rate) is 0.73 %. (POH: 8760 hours per one year (24 hours per one day, 7 days per one week). Average HDA surface temperature: 40 °C or less, workloads: 300 TB per one year, which is defined as the amount of data written, read or verified by commands from host system). Continual or sustained operation at case HDA surface temperature above 40 °C may degrade product reliability.

[17] Workload is defined as the amount of data written, read or verified by commands from host system.

MODEL NUMBER

Model Number	Interface	Capacity	Sector Format	Optional Security
MN10ACA20T	SATA-3.3	20 TB	512e	-

MARKING

1) WEEE

Following information is only for EU-member states:

The use of the symbol indicates that this product may not be treated as household waste. By ensuring this product is disposed of correctly, you will help prevent potential negative consequences for the environment and human health, which could otherwise be caused by inappropriate waste handling of this product. For more detailed information about recycling of this product, please contact your local city office, your household waste disposal service or the shop where you purchased the product.



2) Names and Contents of Hazardous Substances or Elements in Products

产品中有害物质的名称及含量

部件名称	有害物质					
	铅 (Pb)	汞 (Hg)	镉 (Cd)	六价铬 (Cr(VI))	多溴联苯 (PBB)	多溴二苯醚 (PBDE)
HDD(硬盘驱动器)	×	○	○	○	○	○

本表格依据 SJ/T 11364 的规定编制。
○：表示该有害物质在该部件所有均质材料中的含量均在 GB/T 26572 规定的限量要求以下。
×：表示该有害物质至少在该部件的某一均质材料中的含量超出 GB/T 26572 规定的限量要求。



中华人民共和国环保使用期限

SAFETY / EMI STANDARDS

Item
UL (Underwriters Laboratories)
CSA (Canadian Standard Association)
TÜV (Technischer Überwachungs Verein)
BSMI (Bureau of Standards, Metrology and Inspection)
KC (Korea Certification)
RCM (Regulatory Compliance Mark)

(Note) KC Mark											
Made in Japan	 <table border="0"> <tr> <td>1. 기기의 명칭(모델명):</td> <td>MN10ACA20T</td> </tr> <tr> <td>2. 인증번호:</td> <td>R-R-T48-MG10ACA20TE</td> </tr> <tr> <td>3. 인증받은 자의 상호:</td> <td>TOSHIBA ELECTRONIC DEVICES & STORAGE CORPORATION</td> </tr> <tr> <td>4. 제조년월일:</td> <td>2022-01</td> </tr> <tr> <td>5. 제조자 / 제조국가:</td> <td>TOSHIBA ELECTRONIC DEVICES & STORAGE CORPORATION / 일본</td> </tr> </table>	1. 기기의 명칭(모델명):	MN10ACA20T	2. 인증번호:	R-R-T48-MG10ACA20TE	3. 인증받은 자의 상호:	TOSHIBA ELECTRONIC DEVICES & STORAGE CORPORATION	4. 제조년월일:	2022-01	5. 제조자 / 제조국가:	TOSHIBA ELECTRONIC DEVICES & STORAGE CORPORATION / 일본
1. 기기의 명칭(모델명):	MN10ACA20T										
2. 인증번호:	R-R-T48-MG10ACA20TE										
3. 인증받은 자의 상호:	TOSHIBA ELECTRONIC DEVICES & STORAGE CORPORATION										
4. 제조년월일:	2022-01										
5. 제조자 / 제조국가:	TOSHIBA ELECTRONIC DEVICES & STORAGE CORPORATION / 일본										
Made in Philippines	 <table border="0"> <tr> <td>1. 기기의 명칭(모델명):</td> <td>MN10ACA20T</td> </tr> <tr> <td>2. 인증번호:</td> <td>R-R-T48-MG10ACA20TE</td> </tr> <tr> <td>3. 인증받은 자의 상호:</td> <td>TOSHIBA ELECTRONIC DEVICES & STORAGE CORPORATION</td> </tr> <tr> <td>4. 제조년월일:</td> <td>2022-01</td> </tr> <tr> <td>5. 제조자 / 제조국가:</td> <td>TOSHIBA ELECTRONIC DEVICES & STORAGE CORPORATION / 필리핀</td> </tr> </table>	1. 기기의 명칭(모델명):	MN10ACA20T	2. 인증번호:	R-R-T48-MG10ACA20TE	3. 인증받은 자의 상호:	TOSHIBA ELECTRONIC DEVICES & STORAGE CORPORATION	4. 제조년월일:	2022-01	5. 제조자 / 제조국가:	TOSHIBA ELECTRONIC DEVICES & STORAGE CORPORATION / 필리핀
1. 기기의 명칭(모델명):	MN10ACA20T										
2. 인증번호:	R-R-T48-MG10ACA20TE										
3. 인증받은 자의 상호:	TOSHIBA ELECTRONIC DEVICES & STORAGE CORPORATION										
4. 제조년월일:	2022-01										
5. 제조자 / 제조국가:	TOSHIBA ELECTRONIC DEVICES & STORAGE CORPORATION / 필리핀										

B 급 기기 (가정용 방송통신기자재)	이 기기는 가정용 (B 급) 전자파 적합 기기로서 주로 가정에서 사용하는 것을 목적으로 하며, 모든 지역에서 사용할 수 있습니다.
--------------------------------	--

CE Marking

Category	Applied standard	Issued year	Comment
EMC 2014/30/EU	Emission: EN55032	2015	Class B (including domestic environment)
	Immunity: EN55035	2017	Product immunity standard for IT-equipment
RoHS 2011/65/EU	EN IEN63000	2018	Category 3

UKCA Marking

Category	Applied standard	Issued year	Comment
EMC	Emission: BS EN55032	2015	Class B (including domestic environment)
	Immunity: BS EN55035	2017	Product immunity standard for IT-equipment
RoHS	BS EN IEC63000	2018	Category 3

INTERFACE CONNECTOR

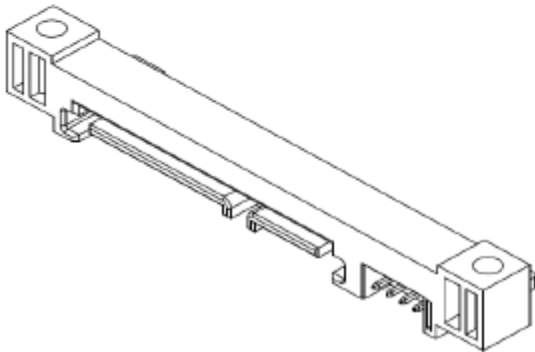
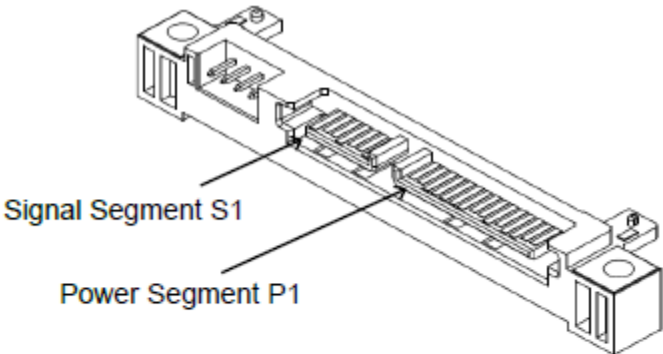

SATA plug connector overview

INTERFACE CONNECTOR (SATA plug) SIGNAL ALLOCATION

Segment	Pin No.		Pin Definition
Signal Segment	S1	GND	2 nd Mate
	S2	A+	Differential Pair A from PHY (Device Rx+)
	S3	A-	Differential Pair A from PHY (Device Rx-)
	S4	GND	2 nd Mate
	S5	B-	Differential Pair B from PHY (Device Tx-)
	S6	B+	Differential Pair B from PHY (Device Tx+)
	S7	GND	2 nd Mate
Power Segment	P1	-	(Unused)
	P2	-	(Unused)
	P3	-	(Unused)
	P4	GND	1 st Mate
	P5	GND	2 nd Mate
	P6	GND	2 nd Mate
	P7	V5	5 V Power Pre-Charge 2 nd Mate
	P8	V5	5 V Power
	P9	V5	5 V Power
	P10	GND	2 nd Mate
	P11	Spin	Staggered Spin-up Mode Detect (Input)
		ACT	Activity LED Drive (Output)
	P12	GND	1 st Mate
	P13	V12	12 V Power Pre-Charge 2 nd Mate
	P14	V12	12 V Power
P15	V12	12 V Power	

Notice: This drive uses 5 V and 12 V power. 3.3 V power is not used.
HDA (Head Disk Assembly) and DC ground (ground pins on interface) are connected electrically each other.

SATA COMMAND TABLE (Part 1)

Op-Code	Command Name
E5h / 98h	CHECK POWER MODE
92h / 93h	DOWNLOAD MICROCODE (DMA)
90h	EXECUTE DIAGNOSTICS
E7h	FLUSH CACHE
EAh	FLUSH CACHE EXT
12h	GET PHYSICAL ELEMENT STATUS
ECh	IDENTIFY DEVICE
E3h / 97h	IDLE
E1h / 95h	IDLE IMMEDIATE
91h	INITIALIZE DEVICE PARAMETERS
00h	NOP
E4h	READ BUFFER
C8h	READ DMA
25h	READ DMA EXT
60h	READ FPDMA QUEUED
47h	READ LOG DMA EXT
2Fh	READ LOG EXT
C4h	READ MULTIPLE
29h	READ MULTIPLE EXT
F8h	READ NATIVE MAX ADDRESS
27h	READ NATIVE MAX ADDRESS EXT
20h	READ SECTOR(S)
24h	READ SECTOR(S) EXT
40h	READ VERIFY SECTOR(s)
42h	READ VERIFY SECTOR(s) EXT

SATA COMMAND TABLE (Part 2)

Op-Code	Command Name
10h	RECALIBRATE
7Ch	REMOVE ELEMENT AND TRUNCATE
0Bh	REQUEST SENSE DATA EXT
B4h	SANITIZE DEVICE
F6h	SECURITY DISABLE PASSWORD
F3h	SECURITY ERASE PREPARE
F4h	SECURITY ERASE UNIT
F5h	SECURITY FREEZE LOCK
F1h	SECURITY SET PASSWORD
F2h	SECURITY UNLOCK
70h	SEEK
77h	SET DATE & TIME EXT
EFh	SET FEATURES
F9h	SET MAX ADDRESS
37h	SET MAX ADDRESS EXT
C6h	SET MULTIPLE MODE
B2h	SET SECTOR CONFIGURATION EXT
E6h / 99h	SLEEP
B0h	SMART Function Set
E2h / 96h	STANDBY
E0h / 94h	STANDBY IMMEDIATE
E8h	WRITE BUFFER
CAh	WRITE DMA
35h	WRITE DMA EXT
3Dh	WRITE DMA FUA EXT
61h	WRITE FPDMA QUEUED
57h	WRITE LOG DMA EXT
3Fh	WRITE LOG EXT
C5h	WRITE MULTIPLE
39h	WRITE MULTIPLE EXT
CEh	WRITE MULTIPLE FUA EXT
30h	WRITE SECTOR(s)
34h	WRITE SECTOR(s) EXT
45h	WRITE UNCORRECTABLE EXT
3Ch	WRITE VERIFY

RESTRICTIONS ON PRODUCT USE

Toshiba Corporation and its subsidiaries and affiliates are collectively referred to as “TOSHIBA”.

Hardware, software and systems described in this document are collectively referred to as “Product”.

- This document and any information herein may not be reproduced without prior written permission from TOSHIBA. Even with TOSHIBA's written permission, reproduction is permissible only if reproduction is without alteration/omission.
- Though TOSHIBA works continually to improve Product's quality and reliability, Product can malfunction or fail. Customers are responsible for complying with safety standards and for providing adequate designs and safeguards for their hardware, software and systems which minimize risk and avoid situations in which a malfunction or failure of Product could cause loss of human life, bodily injury or damage to property, including data loss or corruption. Before customers use the Product, create designs including the Product, or incorporate the Product into their own applications, customers must also refer to and comply with (a) the latest versions of all relevant TOSHIBA information, including without limitation, this document, the specifications, the data sheets and application notes for Product and the precautions and conditions set forth in the "TOSHIBA Semiconductor Reliability Handbook" and (b) the instructions for the application with which the Product will be used with or for. Customers are solely responsible for all aspects of their own product design or applications, including but not limited to (a) determining the appropriateness of the use of this Product in such design or applications; (b) evaluating and determining the applicability of any information contained in this document, or in charts, diagrams, programs, algorithms, sample application circuits, or any other referenced documents; and (c) validating all operating parameters for such designs and applications.
TOSHIBA ASSUMES NO LIABILITY FOR CUSTOMERS' PRODUCT DESIGN OR APPLICATIONS.
- **PRODUCT IS NEITHER INTENDED NOR WARRANTED FOR USE IN EQUIPMENTS OR SYSTEMS THAT REQUIRE EXTRAORDINARILY HIGH LEVELS OF QUALITY AND/OR RELIABILITY, AND/OR A MALFUNCTION OR FAILURE OF WHICH MAY CAUSE LOSS OF HUMAN LIFE, BODILY INJURY, SERIOUS PROPERTY DAMAGE AND/OR SERIOUS PUBLIC IMPACT ("UNINTENDED USE").** Except for specific applications as expressly stated in this document, Unintended Use includes, without limitation, equipment used in nuclear facilities, equipment used in the aerospace industry, lifesaving and/or life supporting medical equipment, equipment used for automobiles, trains, ships and other transportation, traffic signaling equipment, equipment used to control combustions or explosions, safety devices, elevators and escalators, and devices related to power plant. **IF YOU USE PRODUCT FOR UNINTENDED USE, TOSHIBA ASSUMES NO LIABILITY FOR PRODUCT.** For details, please contact your TOSHIBA sales representative or contact us via our website.
- Do not disassemble, analyze, reverse-engineer, alter, modify, translate or copy Product, whether in whole or in part.
- Product shall not be used for or incorporated into any products or systems whose manufacture, use, or sale is prohibited under any applicable laws or regulations.
- The information contained herein is presented only as guidance for Product use. No responsibility is assumed by TOSHIBA for any infringement of patents or any other intellectual property rights of third parties that may result from the use of Product. No license to any intellectual property right is granted by this document, whether express or implied, by estoppel or otherwise.
- **ABSENT A WRITTEN SIGNED AGREEMENT, EXCEPT AS PROVIDED IN THE RELEVANT TERMS AND CONDITIONS OF SALE FOR PRODUCT, AND TO THE MAXIMUM EXTENT ALLOWABLE BY LAW, TOSHIBA (1) ASSUMES NO LIABILITY WHATSOEVER, INCLUDING WITHOUT LIMITATION, INDIRECT, CONSEQUENTIAL, SPECIAL, OR INCIDENTAL DAMAGES OR LOSS, INCLUDING WITHOUT LIMITATION, LOSS OF PROFITS, LOSS OF OPPORTUNITIES, BUSINESS INTERRUPTION AND LOSS OF DATA, AND (2) DISCLAIMS ANY AND ALL EXPRESS OR IMPLIED WARRANTIES AND CONDITIONS RELATED TO SALE, USE OF PRODUCT, OR INFORMATION, INCLUDING WARRANTIES OR CONDITIONS OF MERCHANTABILITY, FITNESS FOR A PARTICULAR PURPOSE, ACCURACY OF INFORMATION, OR NONINFRINGEMENT.**
- Do not use or otherwise make available Product or related software or technology for any military purposes, including without limitation, for the design, development, use, stockpiling or manufacturing of nuclear, chemical, or biological weapons or missile technology products (mass destruction weapons). Product and related software and technology may be controlled under the applicable export laws and regulations including, without limitation, the Japanese Foreign Exchange and Foreign Trade Law and the U.S. Export Administration Regulations. Export and re-export of Product or related software or technology are strictly prohibited except in compliance with all applicable export laws and regulations.
- Product may include products subject to foreign exchange and foreign trade control laws.
- Please contact your TOSHIBA sales representative for details as to environmental matters such as the RoHS compatibility of Product. Please use Product in compliance with all applicable laws and regulations that regulate the inclusion or use of controlled substances, including without limitation, the EU RoHS Directive. **TOSHIBA ASSUMES NO LIABILITY FOR DAMAGES OR LOSSES OCCURRING AS A RESULT OF NONCOMPLIANCE WITH APPLICABLE LAWS AND REGULATIONS**

Toshiba Electronic Devices & Storage Corporation

<https://toshiba.semicon-storage.com/>